

redge<sup>®</sup> FORMERLY  
LENNOX



# COMFORTAIR HD3 COMFORTAIR HD3 ECM

High wall fan coil units



## Application guide



**TABLE OF CONTENTS**

**Introduction**

Introduction	p. 4
--------------	------

**ComfortAir HD3**

Version and main components	p. 5
Technical features	p. 7
Cooling emission	p. 8
Heating emission	p. 11
Water side pressure drop	p. 12
Operation limits	p. 13
Dimension, weight and water content	p. 14
Electronic wall controls for ComfortAir HD3 version	p. 16
Electric heater	p. 17

**ComfortAir HD3 ECM**

Version and main components	p. 18
Technical features	p. 20
Cooling emission	p. 21
Heating emission	p. 24
Water side pressure drop	p. 25
Operation limits	p. 26
Dimension, weight and water content	p. 27
Electronic wall controls for ComfortAir HD3 ECM version	p. 29
Electric heater	p. 30

**ComfortAir HD3 / ComfortAir HD3 ECM controls**

Common controls for ComfortAir HD3 / ComfortAir HD3 ECM	p. 31
---	-------

**ComfortAir HD3 / ComfortAir HD3 ECM accessories**

Accessories	p. 34
-------------	-------

## INTRODUCTION

The CFA / CFA-ECM unit is not a simple high wall fan coil: it is a symphony of engineering and design, result of the passion and pride of Made in Italy.

With a wide spectrum of models and versions, it offers installation versatility suitable for every need, embodying the essence of traditional fan coil efficiency with a modern twist.

Thanks to a modern and appealing design, in the typical RAL 9003 white colour, the unit suits every ambient perfectly, both residential and hotel.

It can house inside a 2 or 3 way valve and the condensate drain pump (optional kits) without the need of any additional rear frame.

It is available in the version with asynchronous motor and in the version with electronic motor.

All the traditional control options are available: infra-red remote control, remote supervisory wall thermostat with Modbus communication protocol.

But what really distinguishes the **CFA / CFA-ECM** is the revolutionary introduction of our BLE solution.

With our innovative **"FANCOIL BLE"** APP, available for Android and iOS systems, you can manage your fan coil at a distance and/or locally by using directly your smartphone.

The graphic interface has been designed to provide the best fan coil management experience, with extreme ease of use, but at the same time the maximum availability of functions and settings.



It is moreover possible to program completely the fan coil operative mode with several time bands for each day of the week in a simple and intuitive way: this allows to combine the maximum comfort with the maximum energy efficiency.



In summary:

- Elegant design suitable for fitting every ambient.
- BLE solution for a complete, user friendly, local and remote wireless control.
- Reduced energy consumption thanks to the use of electronic brushless motors.
- Availability in different variants to satisfy every kind of installation need.
- High quality components for an optimal and lasting performance.
- Italian production to assure the maximum quality and efficiency.

By choosing the **CFA / CFA-ECM** you decide for a high quality comfort and an unprecedented ease of control. Indeed with us, the climate is always at hand.



## VERSION AND MAIN COMPONENTS

### Versions without electric heater

All versions are available without valves, with 2 way valve or with 3 way valve mounted in the factory.

There are four sizes available in the following versions:

**CFA** without infra-red remote control and without valve

**CFA-2V** without infra-red remote control with fitted 2 way valve

**CFA-3V** without infra-red remote control with fitted 3 way valve

**CFA-TA / CFA-TS** with infra-red remote control and without valve

**CFA-TA-2V / CFA-TS-2V** with infra-red remote control with fitted 2 way valve

**CFA-TA-3V / CFA-TS-3V** with infra-red remote control with fitted 3 way valve

**CFA-MBA** with MB electronic board and without valve

**CFA-MBA-2V** with MB electronic board with fitted 2 way valve

**CFA-MBA-3V** with MB electronic board with fitted 3 way valve

### Versions with electric heater

All versions are available without valves, with 2 way valve or with 3 way valve mounted in the factory.

There are four sizes available in the following versions:

**CFA-E** without infra-red remote control and without valve

**CFA-E-2V** without infra-red remote control with fitted 2 way valve

**CFA-E-3V** without infra-red remote control with fitted 3 way valve

**CFA-TA-E** with infra-red remote control and without valve

**CFA-TA-E-2V** with infra-red remote control with fitted 2 way valve

**CFA-TA-E-3V** with infra-red remote control with fitted 3 way valve

**CFA-MBA-E** with MB electronic board and without valve

**CFA-MBA-E-2V** with MB electronic board with fitted 2 way valve

**CFA-MBA-E-3V** with MB electronic board with fitted 3 way valve

The **CFA-TA** and **CFA-MBA** (\*) units offer moreover the possibility of management via **"FANCOIL BLE"** APP. This makes this fan coil unit the ideal solution for the air-conditioning of every kind of ambients; the **CFA-MBA** version allows the connection to a ModBus network.

The electronic board is equipped with a microprocessor with BLE feature, that allows to control at distance or remotely all the units installed.

With the BLE technology it is possible to manage all the fan coil operation modes.

The **CFA-TS** units equipped with remote control and without BLE connectivity are also available.

The CFA-TS includes a simplified control electronics that guarantees all the Fan Coil functions via infra-red remote control (supplied) or via Modbus RTU - RS 485 communication protocol.

(\*) For the **MBA version** it is necessary to use the optional receiver board.

## Construction features

### Casing

Made of auto-extinguishing ABS UL94 HB plastic with high specifications and great resistance to aging. In RAL 9003, shiny surface.

The diffusion flap is adjusted manually (not motorised flap) in CFA version, on the contrary it is adjusted by remote control in CFA-TA version or with DS65 wall control in CFA-MBA version (both with motorised flap).

### Filter

Washable-regenerable synthetic filter, readily accessible.

### Fan assembly

Made of plastic tangential fan.

### Electric motor

The motor is wired for single phase supply and has six speeds, three of which are connected, with capacitor. The motor is fitted on sealed for life bearings and is secured on anti-vibration and self-lubricating mountings. Internal thermal protection with automatic reset, protection IP 20, class B.

The speeds connected in the factory are indicated by "MIN, MED and MAX" in the following tables.

### Coil

It is manufactured from drawn copper tube and the aluminium fins are mechanically bonded onto the tube by an expansion process. The coil has two Ø 1/2 inch BSP internal connections.

The coil has Ø 1/8" inch BSP air vent and drain.

The coil is not suitable for use in corrosive atmosphere or in environments where aluminium may be subject to corrosion.

The connections are on the left side facing the unit only.

## **Condensate collection tray**

The outside diameter of the condensate discharge pipe is Ø 16 mm.

## **Installation template**

A cardboard installation template is supplied with every unit to help the mounting on the wall.

## **Electric heater**

For the electric heater see p. 17

## TECHNICAL FEATURES

### 2 pipe unit

The following standard rating conditions are used:

#### COOLING

Entering air temperature: + 27 °C d.b. + 19 °C w.b.  
Water temperature: +7 °C E.W.T. +12 °C L.W.T.

#### HEATING

Entering air temperature: + 20 °C  
Water temperature: +45 °C E.W.T. +40 °C L.W.T.

MODEL		ComfortAir HD3 1						ComfortAir HD3 2					
Speed		1	2	3	4	5	6	1	2	3	4	5	6
		MIN	MED		MAX			MIN		MED		MAX	
Air flow	m <sup>3</sup> /h	205	270	340	375	470	500	250	305	365	400	480	545
Cooling total emission	kW	1,23	1,49	1,74	1,85	2,13	2,20	1,42	1,62	1,82	1,93	2,16	2,32
Cooling sensible emission	kW	0,91	1,13	1,34	1,44	1,70	1,77	1,06	1,23	1,41	1,51	1,73	1,89
Heating emission	kW	1,34	1,68	2,02	2,18	2,58	2,71	1,58	1,85	2,13	2,29	2,62	2,88
Dp Cooling	kPa	4,8	6,8	9,0	10,1	12,9	13,8	6,2	7,9	9,8	10,8	13,2	15,1
Dp Heating	kPa	4,5	6,8	9,4	10,8	14,7	15,9	6,1	8,1	10,4	11,8	15,1	17,8
Fan	W	12	14	17	18	24	30	12	14	18	20	24	32
Sound power (Lw)	dB(A)	35	41	46	48	52	53	39	43	47	49	53	55
Sound pressure (Lp) <sup>(1)</sup>	dB(A)	26	32	37	39	43	44	30	34	38	40	44	46

MODEL		ComfortAir HD3 3						ComfortAir HD3 4					
Speed		1	2	3	4	5	6	1	2	3	4	5	6
		MIN	MED		MAX			MIN		MED		MAX	
Air flow	m <sup>3</sup> /h	280	375	480	545	730	780	300	440	500	610	675	790
Cooling total emission	kW	1,87	2,30	2,75	3,00	3,59	3,73	1,97	2,60	2,83	3,23	3,43	3,76
Cooling sensible emission	kW	1,33	1,67	2,03	2,24	2,77	2,90	1,41	1,91	2,10	2,44	2,62	2,93
Heating emission	kW	1,89	2,37	2,93	3,23	4,04	4,24	2,00	2,73	3,02	3,53	3,80	4,28
Dp Cooling	kPa	11,2	16,2	22,5	26,3	36,4	39,1	14,1	23,0	27,2	34,0	38,5	45,1
Dp Heating	kPa	9,1	13,8	20,1	24,1	35,9	39,2	12,7	22,2	26,7	35,2	40,4	49,8
Fan	W	16	21	26	29	38	46	17	23	27	32	35	48
Sound power (Lw)	dB(A)	35	40	45	51	55	57	36	43	46	51	54	57
Sound pressure (Lp) <sup>(1)</sup>	dB(A)	26	31	36	42	46	48	27	34	37	42	45	48

<sup>(1)</sup> The sound pressure levels are 9 dB (A) lower than the sound power levels, apply to the reverberant field of a 100 m<sup>3</sup> room and a reverberation time of 0.5 sec.  
MIN-MED-MAX = Speeds connected in the factory

## COOLING EMISSION

Entering air temperature: 27 °C – R.H.: 50%

Model	Vn	Qv m <sup>3</sup> /h	WT: 7 / 12 °C				WT: 8 / 13 °C				WT: 10 / 15 °C				WT: 12 / 17 °C				
			Pc kW	Ps kW	Qw l/h	Dp(c) kPa	Pc kW	Ps kW	Qw l/h	Dp(c) kPa	Pc kW	Ps kW	Qw l/h	Dp(c) kPa	Pc kW	Ps kW	Qw l/h	Dp(c) kPa	
ComfortAir HD3 1	6	500	2,37	1,73	413	15,8	2,12	1,65	370	12,9	1,66	1,56	291	8,3	1,28	1,28	224	5,2	
	5	470	2,29	1,66	399	14,8	2,05	1,59	357	12,1	1,61	1,49	281	7,8	1,23	1,23	216	4,8	
	4	MAX	375	2,00	1,42	347	11,6	1,79	1,35	311	9,5	1,39	1,25	243	6,0	1,06	1,06	185	3,6
	3		340	1,88	1,32	326	10,3	1,68	1,25	292	8,4	1,31	1,16	228	5,3	0,99	0,99	173	3,2
	2	MED	270	1,61	1,11	279	7,8	1,44	1,05	250	6,4	1,12	0,96	194	4,0	0,84	0,84	146	2,4
	1	MIN	205	1,32	0,90	229	5,5	1,19	0,85	207	4,5	0,92	0,76	160	2,8	0,68	0,68	120	1,7
ComfortAir HD3 2	6	545	2,49	1,83	434	17,3	2,23	1,76	390	14,2	1,75	1,66	307	9,1	1,35	1,35	237	5,7	
	5	MAX	480	2,32	1,69	404	15,2	2,08	1,61	361	12,4	1,63	1,51	284	7,9	1,25	1,25	219	4,9
	4		400	2,08	1,49	362	12,5	1,86	1,41	324	10,2	1,45	1,31	253	6,5	1,11	1,11	194	3,9
	3	MED	365	1,97	1,39	341	11,2	1,76	1,32	306	9,1	1,37	1,22	239	5,8	1,04	1,04	182	3,5
	2		305	1,75	1,22	303	9,0	1,57	1,15	272	7,4	1,21	1,06	211	4,7	0,92	0,92	160	2,8
	1	MIN	250	1,52	1,05	264	7,1	1,37	0,99	238	5,8	1,06	0,90	184	3,6	0,79	0,79	138	2,2
ComfortAir HD3 3	6	780	4,01	2,86	698	44,5	3,61	2,71	629	36,6	2,83	2,53	495	23,6	2,17	2,17	381	14,6	
	5		730	3,86	2,74	671	41,4	3,47	2,59	604	34,1	2,72	2,41	475	21,9	2,08	2,08	365	13,5
	4	MAX	545	3,22	2,23	558	29,7	2,90	2,10	504	24,6	2,26	1,92	393	15,6	1,71	1,71	299	9,4
	3		480	2,95	2,02	512	25,4	2,66	1,91	463	21,1	2,07	1,73	360	13,3	1,56	1,56	273	8,0
	2	MED	375	2,46	1,66	427	18,3	2,22	1,56	386	15,2	1,73	1,40	300	9,6	1,29	1,27	225	5,7
	1	MIN	280	2,00	1,33	347	12,6	1,82	1,26	315	10,6	1,41	1,12	245	6,7	1,05	1,00	183	3,9
ComfortAir HD3 4	6	MAX	790	4,04	2,88	704	51,3	3,63	2,73	633	42,2	2,85	2,56	499	27,2	2,19	2,19	384	16,9
	5		675	3,69	2,60	640	43,2	3,32	2,45	576	35,7	2,59	2,27	452	22,8	1,98	1,98	346	14,0
	4	MED	610	3,46	2,42	601	38,6	3,12	2,28	542	31,9	2,44	2,10	424	20,4	1,85	1,85	324	12,4
	3		500	3,04	2,09	527	30,4	2,74	1,97	476	25,2	2,13	1,79	371	16,0	1,61	1,61	281	9,6
	2	MIN	440	2,78	1,90	482	26,0	2,51	1,79	436	21,5	1,95	1,62	340	13,6	1,47	1,47	256	8,1
	1		300	2,11	1,41	365	15,8	1,91	1,33	332	13,2	1,49	1,18	258	8,3	1,10	1,06	193	4,9

WT: Water temperature  
Vn: Nominal speeds  
Qv: Air flow  
Pc: Cooling total emission  
Ps: Cooling sensible emission  
Qw: Water flow rate  
Dp(c): Dp Cooling

Entering air temperature 26 °C – R.H.: 50%

Model	Vn	Qv m <sup>3</sup> /h	WT: 7 / 12 °C				WT: 8 / 13 °C				WT: 10 / 15 °C				WT: 12 / 17 °C				
			Pc kW	Ps kW	Qw l/h	Dp(c) kPa	Pc kW	Ps kW	Qw l/h	Dp(c) kPa	Pc kW	Ps kW	Qw l/h	Dp(c) kPa	Pc kW	Ps kW	Qw l/h	Dp(c) kPa	
ComfortAir HD3 1	6	500	2,11	1,65	368	12,9	1,88	1,60	329	10,4	1,46	1,46	256	6,6	1,11	1,11	196	4,1	
	5	470	2,04	1,58	355	12,0	1,82	1,53	316	9,7	1,41	1,41	246	6,1	1,07	1,07	188	3,8	
	4	MAX	375	1,78	1,35	310	9,4	1,58	1,30	275	7,6	1,22	1,20	213	4,7	0,92	0,92	161	2,8
	3		340	1,67	1,25	291	8,4	1,48	1,20	258	6,7	1,14	1,11	199	4,2	0,86	0,86	150	2,5
	2	MED	270	1,43	1,05	249	6,4	1,27	1,00	221	5,1	0,97	0,92	169	3,1	0,72	0,72	127	1,8
	1	MIN	205	1,18	0,85	205	4,5	1,04	0,80	182	3,6	0,79	0,73	139	2,2	0,59	0,59	103	1,3
ComfortAir HD3 2	6	545	2,22	1,75	387	14,1	1,98	1,70	345	11,4	1,54	1,54	270	7,3	1,18	1,18	208	4,5	
	5	MAX	480	2,07	1,61	360	12,3	1,84	1,56	320	10,0	1,43	1,43	250	6,3	1,09	1,09	191	3,9
	4		400	1,86	1,41	323	10,1	1,65	1,36	287	8,2	1,27	1,27	222	5,1	0,96	0,96	169	3,1
	3	MED	365	1,75	1,32	304	9,1	1,55	1,27	270	7,3	1,20	1,18	209	4,6	0,90	0,90	158	2,7
	2		305	1,56	1,15	270	7,4	1,38	1,10	240	5,9	1,06	1,01	184	3,6	0,79	0,79	139	2,2
	1	MIN	250	1,36	0,99	236	5,8	1,20	0,94	209	4,6	0,92	0,86	160	2,8	0,68	0,68	120	1,7
ComfortAir HD3 3	6	780	3,59	2,71	625	36,5	3,20	2,62	558	29,6	2,49	2,45	435	18,8	1,89	1,89	333	11,5	
	5		730	3,46	2,59	601	34,0	3,08	2,50	536	27,5	2,39	2,32	417	17,4	1,81	1,81	318	10,6
	4	MAX	545	2,88	2,10	501	24,5	2,56	2,01	446	19,7	1,97	1,84	344	12,3	1,48	1,48	259	7,3
	3		480	2,65	1,91	460	21,0	2,35	1,82	409	16,9	1,80	1,66	315	10,4	1,35	1,35	236	6,2
	2	MED	375	2,21	1,57	384	15,1	1,96	1,48	341	12,2	1,50	1,33	261	7,5	1,11	1,11	194	4,4
	1	MIN	280	1,80	1,26	313	10,5	1,61	1,18	279	8,5	1,22	1,05	213	5,2	0,90	0,90	157	3,0
ComfortAir HD3 4	6	MAX	790	3,62	2,73	630	42,1	3,22	2,64	562	34,1	2,51	2,47	439	21,7	1,90	1,90	336	13,2
	5		675	3,30	2,45	574	35,5	2,93	2,36	511	28,6	2,27	2,18	397	18,0	1,72	1,72	302	10,9
	4	MED	610	3,10	2,29	539	31,8	2,76	2,19	480	25,7	2,13	2,02	372	16,0	1,61	1,61	282	9,6
	3		500	2,72	1,97	473	25,1	2,42	1,88	420	20,2	1,86	1,71	324	12,5	1,39	1,39	243	7,4
	2	MIN	440	2,49	1,79	433	21,4	2,22	1,70	385	17,2	1,70	1,54	296	10,6	1,26	1,26	221	6,2
	1		300	1,90	1,33	329	13,1	1,69	1,25	293	10,6	1,28	1,12	224	6,4	0,95	0,95	166	3,7

WT: Water temperature  
Vn: Nominal speeds  
Qv: Air flow  
Pc: Cooling total emission  
Ps: Cooling sensible emission  
Qw: Water flow rate  
Dp(c): Dp Cooling

Entering air temperature: 25 °C – R.H.: 50%

Model	Vn	Qv m <sup>3</sup> /h	WT: 7 / 12 °C				WT: 8 / 13 °C				WT: 10 / 15 °C				WT: 12 / 17 °C				
			Pc kW	Ps kW	Qw l/h	Dp(c) kPa	Pc kW	Ps kW	Qw l/h	Dp(c) kPa	Pc kW	Ps kW	Qw l/h	Dp(c) kPa	Pc kW	Ps kW	Qw l/h	Dp(c) kPa	
ComfortAir HD3 1	6	500	1,87	1,60	328	10,4	1,66	1,55	290	8,3	1,28	1,28	225	6,9	1,06	1,06	188	3,7	
	5	470	1,81	1,53	315	9,7	1,60	1,48	279	7,8	1,23	1,23	216	6,4	1,00	1,00	177	3,4	
	4	MAX	375	1,58	1,30	274	7,6	1,39	1,25	242	6,0	1,06	1,06	186	4,9	0,81	0,81	143	2,3
	3		340	1,48	1,20	257	6,7	1,30	1,15	227	5,3	0,99	0,99	173	4,3	0,74	0,74	130	1,9
	2	MED	270	1,26	1,00	220	5,1	1,11	0,96	193	4,0	0,84	0,84	147	3,2	0,62	0,62	109	1,4
	1	MIN	205	1,04	0,81	181	3,6	0,91	0,76	159	2,8	0,69	0,69	120	2,2	0,50	0,50	89	1,0
ComfortAir HD3 2	6	545	1,97	1,70	345	11,4	1,75	1,65	306	9,2	1,35	1,35	238	7,7	1,13	1,13	201	4,2	
	5	MAX	480	1,83	1,55	319	9,9	1,62	1,50	283	8,0	1,25	1,25	219	6,6	1,03	1,03	181	3,5
	4		400	1,64	1,36	286	8,1	1,45	1,31	253	6,5	1,11	1,11	194	5,3	0,86	0,86	152	2,5
	3	MED	365	1,55	1,27	269	7,3	1,36	1,22	238	5,8	1,04	1,04	182	4,7	0,79	0,79	139	2,2
	2		305	1,37	1,11	239	5,9	1,21	1,06	210	4,7	0,92	0,92	160	3,8	0,68	0,68	120	1,7
	1	MIN	250	1,20	0,95	208	4,6	1,05	0,90	183	3,6	0,80	0,80	139	2,9	0,59	0,59	103	1,3
ComfortAir HD3 3	6	780	3,19	2,61	556	29,5	2,82	2,52	493	23,7	2,18	2,18	382	17,8	1,64	1,64	290	9,0	
	5		730	3,07	2,49	534	27,4	2,72	2,40	474	22,0	2,09	2,09	366	16,5	1,57	1,57	277	8,2
	4	MAX	545	2,55	2,01	444	19,7	2,25	1,92	392	15,7	1,72	1,72	300	11,5	1,28	1,28	225	5,6
	3		480	2,34	1,82	407	16,9	2,06	1,73	359	13,4	1,57	1,57	274	9,8	1,16	1,16	204	4,8
	2	MED	375	1,96	1,48	340	12,2	1,72	1,40	299	9,6	1,29	1,27	226	6,9	0,95	0,95	167	3,3
	1	MIN	280	1,60	1,19	277	8,4	1,40	1,12	244	6,7	1,05	1,00	183	4,8	0,77	0,77	135	2,2
ComfortAir HD3 4	6	MAX	790	3,21	2,64	560	34,0	2,84	2,54	497	27,3	2,19	2,19	385	20,5	1,66	1,66	293	10,4
	5		675	2,92	2,35	509	28,6	2,58	2,26	450	22,9	1,98	1,98	347	17,0	1,49	1,49	262	8,5
	4	MED	610	2,75	2,19	478	25,6	2,43	2,10	423	20,4	1,86	1,86	325	15,1	1,39	1,39	244	7,5
	3		500	2,41	1,88	419	20,2	2,12	1,79	370	16,0	1,61	1,61	282	11,7	1,20	1,20	211	5,7
	2	MIN	440	2,21	1,70	384	17,2	1,94	1,62	338	13,6	1,47	1,47	257	9,9	1,09	1,09	191	4,8
	1		300	1,68	1,26	292	10,5	1,48	1,18	257	8,3	1,11	1,06	193	5,9	0,81	0,81	142	2,8

WT: Water temperature  
Vn: Nominal speeds  
Qv: Air flow  
Pc: Cooling total emission  
Ps: Cooling sensible emission  
Qw: Water flow rate  
Dp(c): Dp Cooling

## HEATING EMISSION

Entering air temperature: 20 °C

Model	Vn	Qv m <sup>3</sup> /h	WT: 70 / 60 °C			WT: 60 / 50 °C			WT: 50 / 40 °C			WT: 50 / 45 °C			WT: 45 / 40 °C			
			Ph kW	Qw l/h	Dp(h) kPa	Ph kW	Qw l/h	Dp(h) kPa	Ph kW	Qw l/h	Dp(h) kPa	Ph kW	Qw l/h	Dp(h) kPa	Ph kW	Qw l/h	Dp(h) kPa	
ComfortAir HD3 1	6	500	5,46	470	15,0	4,22	363	9,7	2,96	254	5,3	3,32	571	22,6	2,71	465	15,9	
	5	470	5,22	449	13,8	4,03	346	9,0	2,83	244	4,9	3,17	546	20,8	2,58	444	14,7	
	4	MAX	375	4,40	378	10,1	3,40	293	6,6	2,40	206	3,6	2,67	460	15,3	2,18	375	10,8
	3		340	4,07	350	8,8	3,16	271	5,8	2,23	191	3,2	2,48	426	13,3	2,02	347	9,4
	2	MED	270	3,39	292	6,4	2,63	226	4,2	1,86	160	2,3	2,06	354	9,6	1,68	289	6,8
	1	MIN	205	2,71	233	4,2	2,11	181	2,8	1,50	129	1,6	1,64	283	6,4	1,34	231	4,5
ComfortAir HD3 2	6	545	5,82	501	16,8	4,49	386	10,9	3,15	271	6,0	3,54	609	25,4	2,88	496	17,8	
	5	MAX	480	5,30	456	14,2	4,09	352	9,2	2,87	247	5,0	3,22	554	21,4	2,62	451	15,1
	4		400	4,62	397	11,1	3,57	307	7,2	2,52	216	4,0	2,81	483	16,7	2,29	394	11,8
	3	MED	365	4,31	370	9,8	3,33	287	6,4	2,35	202	3,5	2,62	450	14,7	2,13	367	10,4
	2		305	3,74	322	7,6	2,90	249	4,9	2,05	176	2,7	2,27	391	11,4	1,85	319	8,1
	1	MIN	250	3,19	274	5,7	2,47	213	3,7	1,75	151	2,1	1,93	333	8,5	1,58	272	6,1
ComfortAir HD3 3	6	780	8,54	734	36,7	6,61	569	24,0	4,68	403	13,4	5,19	893	55,5	4,24	729	39,2	
	5	730	8,13	699	33,6	6,31	542	22,0	4,46	384	12,3	4,94	850	50,8	4,04	694	35,9	
	4	MAX	545	6,51	560	22,5	5,06	435	14,8	3,59	309	8,3	3,95	680	34,0	3,23	556	24,1
	3		480	5,89	507	18,8	4,58	394	12,4	3,26	280	7,0	3,57	615	28,4	2,93	503	20,1
	2	MED	375	4,78	411	12,9	3,72	320	8,5	2,66	229	4,8	2,90	498	19,4	2,37	408	13,8
	1	MIN	280	3,79	326	8,5	2,96	255	5,7	2,13	183	3,2	2,30	395	12,8	1,89	324	9,1
ComfortAir HD3 4	6	MAX	790	8,62	741	46,6	6,68	574	30,5	4,72	406	16,9	5,24	902	70,5	4,28	736	49,8
	5		675	7,66	659	37,7	5,95	511	24,7	4,21	362	13,8	4,66	801	57,0	3,80	654	40,3
	4	MED	610	7,11	611	32,9	5,52	475	21,6	3,92	337	12,1	4,32	743	49,7	3,53	607	35,2
	3		500	6,08	523	24,9	4,73	407	16,4	3,37	290	9,2	3,69	635	37,5	3,02	520	26,6
	2	MIN	440	5,49	472	20,7	4,28	368	13,7	3,05	262	7,7	3,34	574	31,2	2,73	469	22,2
	1		300	4,02	346	11,8	3,14	270	7,8	2,25	193	4,4	2,43	419	17,7	2,00	344	12,7

WT: Water temperature  
Vn: Nominal speeds  
Qv: Air flow  
Ph: Heating emission  
Qw: Water flow rate  
Dp(h): Dp Heating

## WATER SIDE PRESSURE DROP

### Coil pressure drop

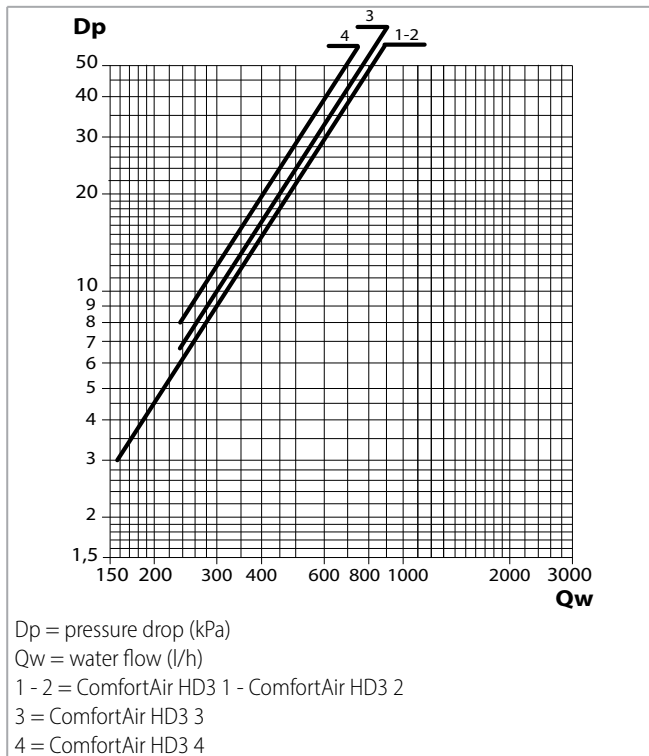

The water pressure drop figures refer to a mean water temperature of 10 °C; for different temperatures, multiply the pressure drop figures by the correction factors K.

K correction factor	Mean water temperature (°C)						
	20	30	40	50	60	70	80
	0,94	0,90	0,86	0,82	0,78	0,74	0,70

### Valves pressure drop

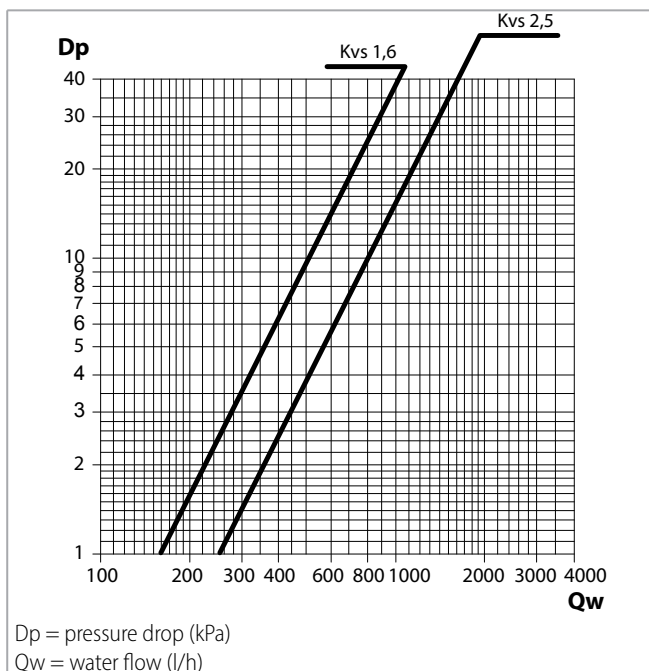

## OPERATION LIMITS

Description		UoM	Value
Water flow	Coil maximum working pressure	bars	10
		kPa	1000
	Lowest water inlet temperature <sup>(1)</sup>	°C	+6
	Highest water inlet temperature	°C	+70
Power supply	Single-phase rated operating voltage	V/Hz	230/50

(1) for entering water temperatures below +6 °C, contact the technical department

## Installation height

Model		ComfortAir HD3 1	ComfortAir HD3 2	ComfortAir HD3 3	ComfortAir HD3 4
Minimum installation height	m		2		
Maximum installation height	m		3		

## Motor electrical data - max. absorption

Model		ComfortAir HD3 1	ComfortAir HD3 2	ComfortAir HD3 3	ComfortAir HD3 4
Motor absorption	W	30	32	46	48
Current absorbed	A		0,16		0,23



## DIMENSION, WEIGHT AND WATER CONTENT

### Dimensions

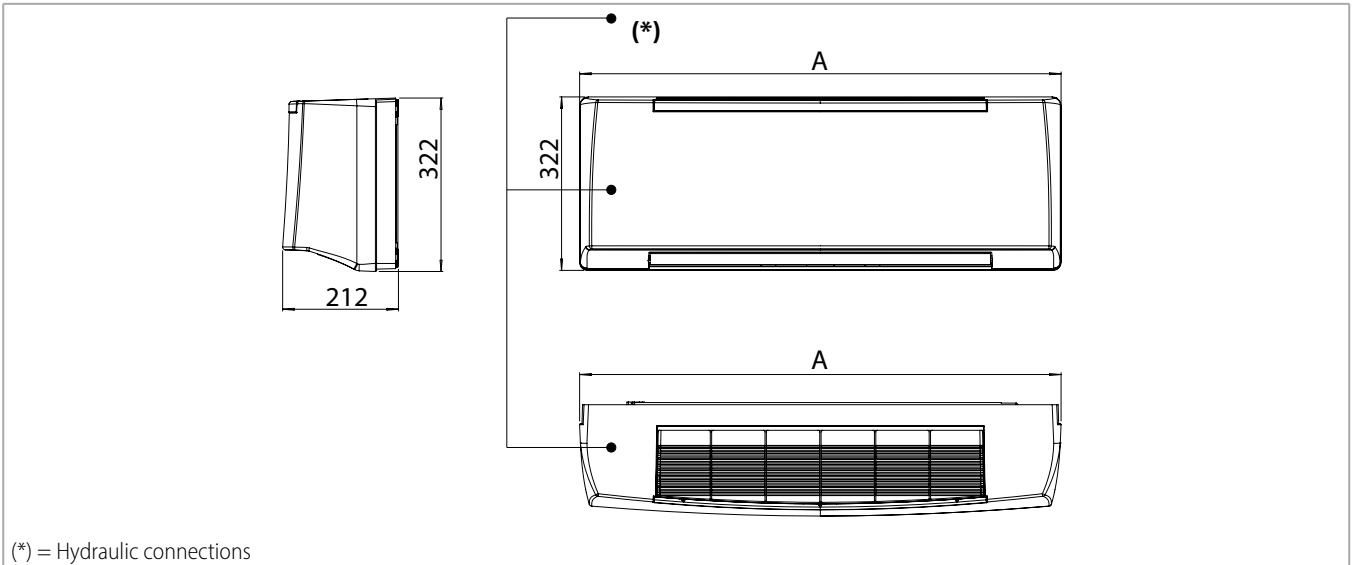

Model		ComfortAir HD3 1	ComfortAir HD3 2	ComfortAir HD3 3	ComfortAir HD3 4
A	mm		880		1185

### Fixing dimensions

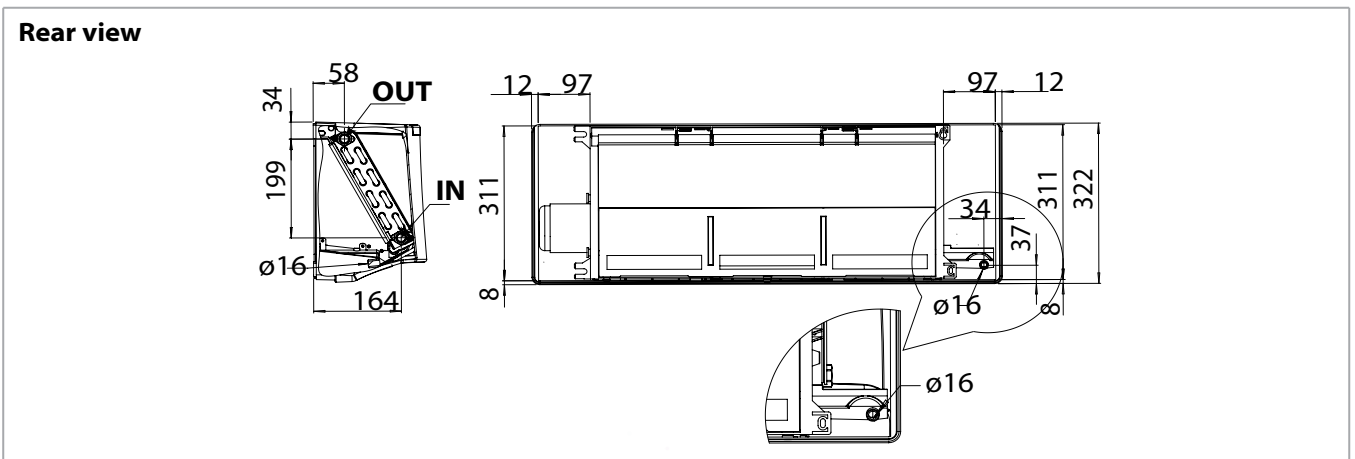
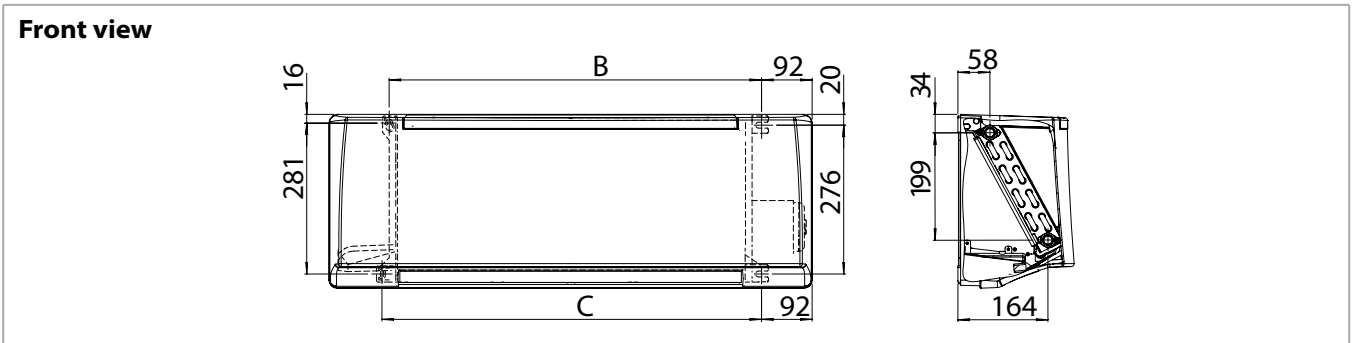

Model		ComfortAir HD3 1	ComfortAir HD3 2	ComfortAir HD3 3	ComfortAir HD3 4
B	mm		678		983
C	mm		691		996

### Packed unit

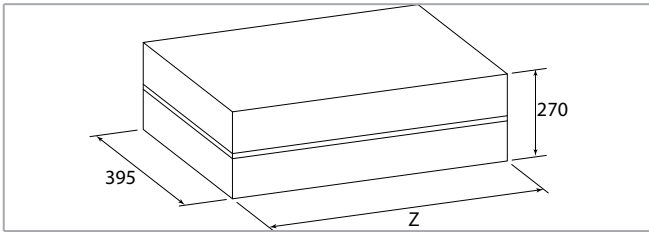

Model		ComfortAir HD3 1	ComfortAir HD3 2	ComfortAir HD3 3	ComfortAir HD3 4
Z	mm	950		1255	

### Weight

#### Weight with packaging

Model		ComfortAir HD3 1	ComfortAir HD3 2	ComfortAir HD3 3	ComfortAir HD3 4
Weight with packaging without valves	kg	12		16	
Weight with packaging with valves	kg	13		17	

#### Weight without packaging

Model		ComfortAir HD3 1	ComfortAir HD3 2	ComfortAir HD3 3	ComfortAir HD3 4
Weight without packaging without valves	kg	10		13	
Weight without packaging with valves	kg	11		14	

### Water content

Model		ComfortAir HD3 1	ComfortAir HD3 2	ComfortAir HD3 3	ComfortAir HD3 4
Water content	l	0,9		1,3	

**ELECTRONIC WALL CONTROLS FOR COMFORTAIR HD3 VERSION**

All the units of the **CFA** range can be supplied with a wide range of wall controls that allows managing one single unit or several units (with the use of speed switches).

The options range from the basic **WM-3V**, only for 3-speed control, to the highly sophisticated **TOTI** and

**T2T2** electronic room thermostats, that regulate the room temperature precisely and are suitable when the user wants to set the fan speed.

**Note:** all the controls are described in detail in the AGU.

**Controls**

**WM-3V control**



230V 50 Hz

**TOTI control**



230V 50-60 Hz

**T2T2 control**



230V 50-60 Hz

**RCFF control**

ID	Code
RCFF	LXTFF01M



With AC 3 speed motor

- 2 pipes On/OFF
- 2 pipes 3pts valve
- 2 pipes ON/OFF + EH
- 4 pipes ON/OFF
- 4 pipes 3pts valve

## ELECTRIC HEATER

According to the control provided, the electrical heater can be used as an alternative or as a supplement to the hot water.

The heater is hermetically sealed and supplied inside the coil pipes and therefore can be only factory mounted.

The electric heaters of the **CFA** units are single phase 230 V supply.

The electric heater is fitted with a overheat protection. The unit is fitted with two safety thermostats:

- one thermostat with manual reset.
- one thermostat with automatic reset.

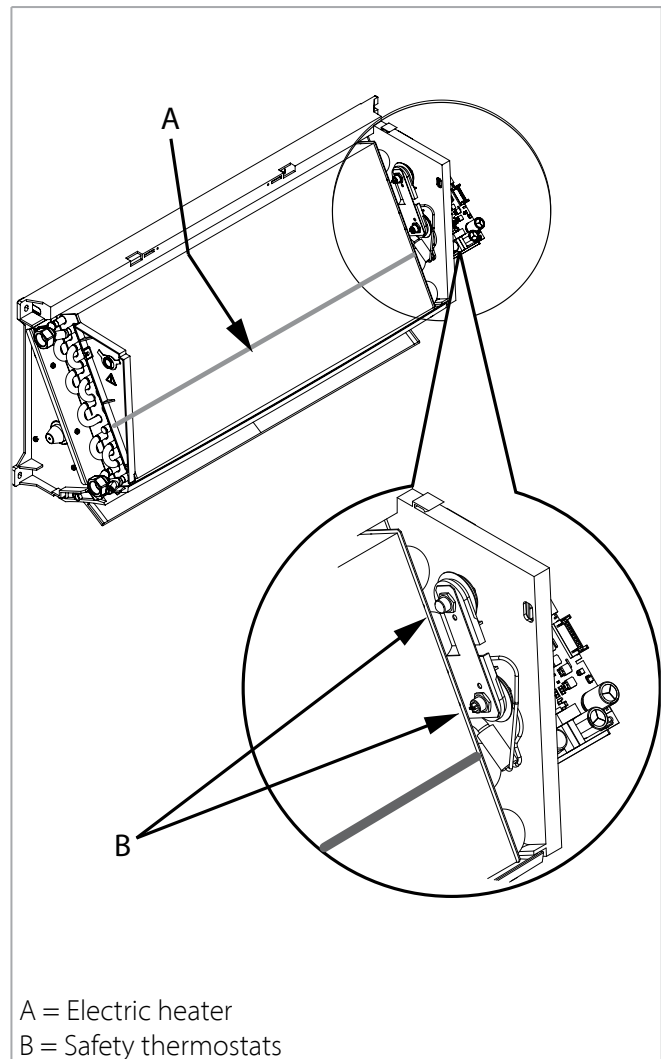

## Constructional features of the main components

Model		ComfortAir HD3 1	ComfortAir HD3 2	ComfortAir HD3 3	ComfortAir HD3 4
Nominal installed power	W	1000			1500
Maximum current absorbed	A	4,5			7,0
Recommended fuse <sup>(1)</sup>	A	6 <sup>(2)</sup>			8 <sup>(2)</sup>
Power supply	V/ph/Hz	230/1/50			
Connecting wires	n x mm <sup>2</sup>	3 x 1,5			

<sup>(1)</sup> for the overload protection; gG type

<sup>(2)</sup> gG type for overload protection

## Operating limits with electric heater

Max. ambient temperature for CFA with electric heater in heating mode: 25 °C.

## VERSION AND MAIN COMPONENTS

### Versions without electric heater

All versions are available without valves, with 2 way valve or with 3 way valve mounted in the factory.

There are five sizes available in the following versions:

**CFA-ECM-A** without infra-red remote control and without valve

**CFA-ECM-A-2V** without infra-red remote control with fitted 2 way valve

**CFA-ECM-A-3V** without infra-red remote control with fitted 3 way valve

**CFA-ECM-TA / CFA-ECM-TS** with infra-red remote control and without valve

**CFA-ECM-TA-2V / CFA-ECM-TS-2V** with infra-red remote control with fitted 2 way valve

**CFA-ECM-TA-3V / CFA-ECM-TS-3V** with infra-red remote control with fitted 3 way valve

**CFA-ECM-MB** with MB electronic board and without valve

**CFA-ECM-MB-2V** with MB electronic board with fitted 2 way valve

**CFA-ECM-MB-3V** with MB electronic board with fitted 3 way valve

### Versions with electric heater

All versions are available without valves, with 2 way valve or with 3 way valve mounted in the factory.

Four sizes are provided (the size 0 is not available) in the following versions:

**CFA-ECM-A-E** without infra-red remote control and without valve

**CFA-ECM-A-E-2V** without infra-red remote control with fitted 2 way valve

**CFA-ECM-A-E-3V** without infra-red remote control with fitted 3 way valve

**CFA-ECM-TA-E** with infra-red remote control and without valve

**CFA-ECM-TA-E-2V** with infra-red remote control with fitted 2 way valve

**CFA-ECM-TA-E-3V** with infra-red remote control with fitted 3 way valve

**CFA-ECM-MB-E** with MB electronic board and without valve

**CFA-ECM-MB-E-2V** with MB electronic board with fitted 2 way valve

**CFA-ECM-MB-E-3V** with MB electronic board with fitted 3 way valve

The **CFA-ECM-TA** and **CFA-ECM-MB** (\*) units offer moreover the possibility of management via "FANCOIL BLE" APP. This makes this fan coil unit the ideal solution for the air-conditioning of every kind of

ambients; the **CFA-ECM-MB** version allows the connection to a ModBus network.

The electronic board is equipped with a microprocessor with BLE feature, that allows to control at distance or remotely all the units installed.

With the BLE technology it is possible to manage all the fan coil operation modes.

The **CFA-ECM-TS** units equipped with remote control and without BLE connectivity are also available.

The CFA-ECM-TS includes a simplified control electronics that guarantees all the Fan Coil functions via infra-red remote control (supplied) or via Modbus RTU - RS 485 communication protocol.

(\*) For the **ECM-MBA version** it is necessary to use the optional receiver board.

## Construction features

### Casing

Made of auto-extinguishing ABS UL94 HB plastic with high specifications and great resistance to aging. In RAL 9003, shiny surface.

The diffusion flap is adjusted manually (not motorised flap) in CFA-ECM-A version, on the contrary it is adjusted by remote control in CFA-ECM-TA version or with DS65 wall control in CFA-ECM-MB version (both with motorised flap).

### Filter

Washable-regenerable synthetic filter, readily accessible.

### Fan assembly

Made of plastic tangential fan.

### Electronic motor

Electronic motor with three phase permanent magnet brushless electronic motor that is controlled with reconstructed current according to a BLAC sinusoidal wave.

The inverter board that controls the motor operation is powered by 230 Volt, single-phase and, with a switching system, it generates a three-phase frequency modulated, wave form power supply.

The electric power supply required for the machine is therefore single-phase with voltage of 230 V and frequency of 50 - 60 Hz.

### Coil

It is manufactured from drawn copper tube and the aluminium fins are mechanically bonded onto the tube by an expansion process.

The coil has two Ø 1/2 inch BSP internal connections.  
The coil has Ø 1/8" inch BSP air vent and drain.  
The coil is not suitable for use in corrosive atmosphere or in environments where aluminium may be subject to corrosion.  
The connections are on the left side facing the unit only.

**Condensate collection tray**

The outside diameter of the condensate discharge pipe is Ø 16 mm.

**Installation template**

A cardboard installation template is supplied with every unit to help the mounting on the wall.

**Electric heater**

For the electric heater see p. 30

## TECHNICAL FEATURES

### 2 pipe unit

The following standard rating conditions are used:

#### COOLING

Entering air temperature: + 27 °C d.b. + 19 °C w.b.  
Water temperature: +7 °C E.W.T. +12 °C L.W.T.

#### HEATING

Entering air temperature: + 20 °C  
Water temperature: +45 °C E.W.T. +40 °C L.W.T.

MODEL		ComfortAir HD3 ECM 0						ComfortAir HD3 ECM 1				
Inverter speed signal (Vdc)		1	2	3	5	7,5	10	1	3	5	7,5	10
		MIN			MED		MAX	MIN		MED		MAX
Air flow	m <sup>3</sup> /h	130	148	230	290	340	415	190	240	290	355	415
Cooling total emission	kW	0,61	0,86	1,28	1,57	1,78	1,98	1,16	1,38	1,57	1,80	1,98
Cooling sensible emission	kW	0,47	0,66	0,90	1,19	1,38	1,56	0,85	1,03	1,19	1,39	1,56
Heating emission	kW	0,72	1,05	1,48	1,78	2,15	2,35	1,26	1,53	1,78	2,09	2,35
Dp Cooling	kPa	1,4	2,6	5,2	7,7	9,4	11,2	5,0	5,9	7,7	9,4	11,2
Dp Heating	kPa	1,6	3,0	5,6	7,5	12,0	12,4	4,0	5,7	7,5	10,0	12,4
Fan	W	3	4	7	9	10	15	6	7	9	11	15
Sound power (Lw)	dB(A)	26	30	38	46	49	52	35	39	46	48	52
Sound pressure (Lp) <sup>(1)</sup>	dB(A)	17	21	29	37	40	43	26	30	37	39	43

MODEL		ComfortAir HD3 ECM 2					ComfortAir HD3 ECM 3				
Inverter speed signal (Vdc)		1	3	5	7,5	10	1	3	5	7,5	10
		MIN		MED		MAX	MIN		MED		MAX
Air flow	m <sup>3</sup> /h	260	315	375	440	510	270	345	420	520	620
Cooling total emission	kW	1,46	1,66	1,86	2,05	2,24	1,82	2,19	2,52	2,92	3,27
Cooling sensible emission	kW	1,09	1,27	1,45	1,63	1,81	1,30	1,59	1,85	2,17	2,48
Heating emission	kW	1,63	1,90	2,18	2,46	2,74	1,83	2,24	2,63	3,11	3,57
Dp Cooling	kPa	6,9	8,2	10,1	12,0	14,1	10,7	14,8	19,0	24,8	30,4
Dp Heating	kPa	6,4	8,4	10,8	13,4	16,3	8,7	12,5	16,6	22,5	28,8
Fan	W	7	9	12	16	21	6	8	11	15	20
Sound power (Lw)	dB(A)	40	44	47	51	55	37	42	45	49	53
Sound pressure (Lp) <sup>(1)</sup>	dB(A)	31	35	38	42	46	28	33	36	40	44

MODEL		ComfortAir HD3 ECM 4				
Inverter speed signal (Vdc)		1	3	5	7,5	10
		MIN		MED		MAX
Air flow	m <sup>3</sup> /h	375	465	550	665	770
Cooling total emission	kW	2,33	2,71	3,03	3,41	3,72
Cooling sensible emission	kW	1,69	2,00	2,27	2,61	2,89
Heating emission	kW	2,40	2,85	3,26	3,76	4,20
Dp Cooling	kPa	16,5	21,6	26,6	32,9	38,7
Dp Heating	kPa	14,1	19,3	24,4	31,7	38,6
Fan	W	9	12	16	22	30
Sound power (Lw)	dB(A)	43	46	49	53	57
Sound pressure (Lp) <sup>(1)</sup>	dB(A)	34	37	40	44	48

<sup>(1)</sup> The sound pressure levels are 9 dB (A) lower than the sound power levels, apply to the reverberant field of a 100 m<sup>3</sup> room and a reverberation time of 0.5 sec.

**COOLING EMISSION**

**Entering air temperature: 27 °C – R.H.: 50%**

Model	Vdc	Qv m <sup>3</sup> /h	WT: 7 / 12 °C				WT: 8 / 13 °C				WT: 10 / 15 °C				WT: 12 / 17 °C			
			Pc kW	Ps kW	Qw l/h	Dp(c) kPa	Pc kW	Ps kW	Qw l/h	Dp(c) kPa	Pc kW	Ps kW	Qw l/h	Dp(c) kPa	Pc kW	Ps kW	Qw l/h	Dp(c) kPa
ComfortAir HD3 ECM 0	10	415	2,14	1,53	370	12,9	1,91	1,46	331	10,5	1,49	1,36	259	6,7	1,14	1,14	198	4,1
	7,5	340	1,94	1,37	335	10,8	1,74	1,30	300	8,8	1,35	1,20	234	5,6	1,03	1,03	178	3,4
	5	290	1,69	1,18	293	8,5	1,52	1,11	263	7,0	1,18	1,02	204	4,4	0,89	0,89	154	2,6
	3	230	1,50	0,99	259	6,7	1,36	0,92	234	5,6	1,04	0,79	180	3,4	0,76	0,76	131	1,9
	2	148	1,07	0,70	185	3,5	0,97	0,65	167	2,7	0,76	0,57	130	1,9	0,55	0,55	95	1,1
	1	130	0,97	0,63	167	2,8	0,88	0,59	151	2,3	0,68	0,51	117	1,5	0,45	0,45	77	0,8
ComfortAir HD3 ECM 1	10	415	2,14	1,53	370	12,9	1,91	1,46	331	10,5	1,49	1,36	259	6,7	1,14	1,14	198	4,1
	7,5	355	1,94	1,37	335	10,8	1,74	1,30	300	8,8	1,35	1,20	234	5,6	1,03	1,03	178	3,4
	5	290	1,69	1,18	293	8,5	1,52	1,11	263	7,0	1,18	1,02	204	4,4	0,89	0,89	154	2,6
	3	240	1,49	1,02	257	6,7	1,34	0,96	231	5,5	1,03	0,88	179	3,4	0,77	0,77	134	2,0
	1	190	1,25	0,85	217	4,9	1,13	0,80	196	4,1	0,87	0,72	151	2,5	0,65	0,65	113	1,5
ComfortAir HD3 ECM 2	10	510	2,41	1,76	418	16,1	2,16	1,69	375	13,2	1,69	1,59	295	8,5	1,30	1,30	227	5,3
	7,5	440	2,21	1,59	383	13,8	1,98	1,52	343	11,2	1,55	1,42	269	7,2	1,18	1,18	206	4,4
	5	375	2,01	1,43	347	11,5	1,80	1,35	311	9,4	1,40	1,26	243	6,0	1,07	1,07	185	3,6
	3	315	1,79	1,26	309	9,4	1,61	1,19	278	7,7	1,25	1,09	216	4,8	0,94	0,94	164	2,9
	1	260	1,57	1,09	271	7,4	1,41	1,03	244	6,1	1,09	0,94	189	3,8	0,82	0,82	142	2,3
ComfortAir HD3 ECM 3	10	620	3,51	2,46	607	34,6	3,16	2,32	547	28,6	2,47	2,14	428	18,2	1,88	1,88	327	11,1
	7,5	520	3,13	2,16	541	28,1	2,83	2,04	489	23,3	2,20	1,86	381	14,8	1,67	1,67	289	8,9
	5	420	2,70	1,84	467	21,5	2,44	1,74	422	17,9	1,90	1,57	329	11,3	1,43	1,43	247	6,7
	3	345	2,35	1,58	405	16,7	2,13	1,49	367	13,9	1,65	1,34	286	8,8	1,24	1,21	214	5,2
	1	270	1,96	1,30	338	12,0	1,78	1,23	307	10,1	1,38	1,09	239	6,4	1,03	0,98	178	3,7
ComfortAir HD3 ECM 4	10	770	4,00	2,85	693	44,0	3,60	2,70	624	36,2	2,83	2,53	491	23,3	2,17	2,17	378	14,4
	7,5	665	3,67	2,58	634	37,5	3,30	2,43	571	30,9	2,58	2,26	448	19,8	1,97	1,97	343	12,1
	5	550	3,25	2,25	562	30,1	2,93	2,12	507	24,9	2,29	1,95	396	15,8	1,73	1,73	301	9,6
	3	465	2,90	1,99	501	24,5	2,62	1,87	453	20,3	2,04	1,70	353	12,8	1,54	1,54	267	7,7
	1	375	2,50	1,69	431	18,7	2,26	1,59	390	15,5	1,75	1,43	303	9,8	1,32	1,30	228	5,8

WT: Water temperature  
Vdc: Inverter speed signal (Vdc)  
Qv: Air flow  
Pc: Cooling total emission  
Ps: Cooling sensible emission  
Qw: Water flow rate  
Dp(c): Dp Cooling

Entering air temperature 26 °C – R.H.: 50%

Model	Vdc	WT: 7 / 12 °C					WT: 8 / 13 °C					WT: 10 / 15 °C					WT: 12 / 17 °C				
		Qv m <sup>3</sup> /h	Pc kW	Ps kW	Qw l/h	Dp(c) kPa	Pc kW	Ps kW	Qw l/h	Dp(c) kPa	Pc kW	Ps kW	Qw l/h	Dp(c) kPa	Pc kW	Ps kW	Qw l/h	Dp(c) kPa			
ComfortAir HD3 ECM 0	10	415	1,90	1,46	330	10,5	1,69	1,40	293	8,5	1,31	1,31	227	5,3	0,99	0,99	173	3,2			
	7,5	340	1,73	1,30	299	8,8	1,53	1,25	265	7,1	1,18	1,16	205	4,4	0,89	0,89	155	2,6			
	5	290	1,51	1,12	261	6,9	1,34	1,07	232	5,5	1,03	0,98	178	3,4	0,77	0,77	134	2,0			
	3	230	1,30	0,90	224	4,8	1,15	0,86	198	4,2	0,85	0,75	146	2,2	0,60	0,60	103	1,2			
	2	148	0,96	0,65	165	2,6	0,86	0,61	148	2,2	0,65	0,52	111	1,4	0,51	0,51	88	0,9			
	1	130	0,87	0,59	149	2,3	0,78	0,55	133	1,9	0,58	0,47	100	1,1	0,46	0,46	80	0,8			
ComfortAir HD3 ECM 1	10	415	1,90	1,46	330	10,5	1,69	1,40	293	8,5	1,31	1,31	227	5,3	0,99	0,99	173	3,2			
	7,5	355	1,73	1,30	299	8,8	1,53	1,25	265	7,1	1,18	1,16	205	4,4	0,89	0,89	155	2,6			
	5	290	1,51	1,12	261	6,9	1,34	1,07	232	5,5	1,03	0,98	178	3,4	0,77	0,77	134	2,0			
	3	240	1,33	0,97	230	5,5	1,17	0,92	203	4,4	0,90	0,84	155	2,7	0,67	0,67	116	1,6			
	1	190	1,12	0,81	194	4,1	0,99	0,76	172	3,2	0,76	0,69	131	2,0	0,56	0,56	97	1,1			
ComfortAir HD3 ECM 2	10	510	2,15	1,68	373	13,1	1,91	1,63	333	10,6	1,49	1,49	260	6,7	1,14	1,14	199	4,1			
	7,5	440	1,97	1,52	342	11,2	1,75	1,47	304	9,0	1,36	1,36	236	5,7	1,03	1,03	180	3,5			
	5	375	1,79	1,35	310	9,4	1,59	1,30	275	7,5	1,22	1,21	213	4,7	0,92	0,92	161	2,8			
	3	315	1,60	1,19	276	7,6	1,42	1,14	245	6,1	1,09	1,05	188	3,8	0,82	0,82	142	2,3			
	1	260	1,40	1,03	243	6,1	1,24	0,98	215	4,8	0,95	0,89	165	3,0	0,71	0,71	123	1,7			
ComfortAir HD3 ECM 3	10	620	3,15	2,32	545	28,5	3,27	2,48	565	30,4	2,16	2,05	375	14,4	1,83	1,83	318	26,6			
	7,5	520	2,81	2,04	486	23,2	2,92	2,17	504	24,8	1,92	1,78	333	11,6	1,62	1,62	282	21,4			
	5	420	2,43	1,74	420	17,8	2,52	1,85	436	19,0	1,65	1,49	286	8,8	1,39	1,39	242	16,2			
	3	345	2,11	1,50	365	13,8	2,19	1,59	379	14,8	1,44	1,27	248	6,8	1,21	1,19	209	12,5			
	1	270	1,76	1,23	304	10,0	1,83	1,31	316	10,7	1,20	1,03	207	4,9	1,01	0,96	174	9,0			
ComfortAir HD3 ECM 4	10	770	3,58	2,70	621	36,0	3,19	2,61	554	29,2	2,48	2,43	432	18,5	1,89	1,89	330	11,3			
	7,5	665	3,28	2,44	568	30,7	2,92	2,34	506	24,8	2,26	2,17	393	15,6	1,71	1,71	298	9,4			
	5	550	2,91	2,13	504	24,8	2,59	2,03	449	20,0	2,00	1,87	346	12,4	1,50	1,50	261	7,4			
	3	465	2,60	1,88	450	20,2	2,32	1,79	400	16,3	1,78	1,63	308	10,0	1,33	1,33	231	5,9			
	1	375	2,24	1,60	387	15,4	2,00	1,51	345	12,4	1,53	1,36	264	7,6	1,13	1,13	196	4,4			

WT: Water temperature  
Vdc: Inverter speed signal (Vdc)  
Qv: Air flow  
Pc: Cooling total emission  
Ps: Cooling sensible emission  
Qw: Water flow rate  
Dp(c): Dp Cooling

Entering air temperature: 25 °C – R.H.: 50%

Model	Vdc	WT: 7 / 12 °C					WT: 8 / 13 °C					WT: 10 / 15 °C					WT: 12 / 17 °C				
		Qv m³/h	Pc kW	Ps kW	Qw l/h	Dp(c) kPa	Pc kW	Ps kW	Qw l/h	Dp(c) kPa	Pc kW	Ps kW	Qw l/h	Dp(c) kPa	Pc kW	Ps kW	Qw l/h	Dp(c) kPa			
ComfortAir HD3 ECM 0	10	415	1,68	1,40	292	8,5	1,49	1,35	258	6,7	1,14	1,14	199	4,2	0,90	0,90	157	2,7			
	7,5	340	1,53	1,25	264	7,1	1,35	1,20	233	5,6	1,03	1,03	179	3,4	0,77	0,77	135	2,1			
	5	290	1,33	1,07	231	5,5	1,17	1,02	203	4,4	0,89	0,89	155	2,7	0,66	0,66	116	1,6			
	3	230	1,10	0,87	189	4,0	1,00	0,80	178	3,4	0,75	0,75	140	2,1	0,55	0,55	95	1,1			
	2	148	0,85	0,61	146	2,3	0,75	0,57	129	1,9	0,57	0,55	98	1,2	0,45	0,43	77	0,8			
	1	130	0,77	0,55	132	1,9	0,68	0,51	116	1,6	0,51	0,50	88	1,0	0,40	0,40	69	0,7			
ComfortAir HD3 ECM 1	10	415	1,68	1,40	292	8,5	1,49	1,35	258	6,7	1,14	1,14	199	4,2	0,90	0,90	157	2,7			
	7,5	355	1,53	1,25	264	7,1	1,35	1,20	233	5,6	1,03	1,03	179	3,4	0,77	0,77	135	2,1			
	5	290	1,33	1,07	231	5,5	1,17	1,02	203	4,4	0,89	0,89	155	2,7	0,66	0,66	116	1,6			
	3	240	1,17	0,92	202	4,4	1,03	0,87	178	3,4	0,78	0,78	135	2,1	0,57	0,57	100	1,2			
	1	190	0,99	0,76	171	3,2	0,87	0,72	150	2,5	0,65	0,65	113	1,5	0,48	0,48	83	0,9			
ComfortAir HD3 ECM 2	10	510	1,90	1,63	331	10,6	1,69	1,58	294	8,5	1,31	1,31	228	5,3	1,09	1,09	191	3,9			
	7,5	440	1,75	1,46	303	9,0	1,54	1,41	268	7,2	1,19	1,19	207	4,5	0,95	0,95	166	3,0			
	5	375	1,58	1,30	274	7,5	1,40	1,25	242	6,0	1,07	1,07	186	3,7	0,82	0,82	143	2,3			
	3	315	1,41	1,14	244	6,1	1,24	1,09	215	4,9	0,95	0,95	164	3,0	0,71	0,71	123	1,7			
	1	260	1,24	0,98	214	4,8	1,09	0,93	188	3,8	0,82	0,82	143	2,3	0,61	0,61	106	1,3			
ComfortAir HD3 ECM 3	10	620	2,79	2,23	483	22,9	2,46	2,13	427	18,3	1,89	1,89	328	11,3	1,42	1,42	247	6,7			
	7,5	520	2,49	1,95	430	18,6	2,19	1,86	380	14,8	1,67	1,67	290	9,0	1,25	1,25	217	5,3			
	5	420	2,15	1,65	371	14,3	1,89	1,57	328	11,3	1,43	1,42	248	6,8	1,06	1,06	185	4,0			
	3	345	1,87	1,41	323	11,1	1,65	1,34	284	8,8	1,24	1,20	215	5,3	0,91	0,91	159	3,0			
	1	270	1,57	1,16	270	8,1	1,37	1,09	237	6,4	1,03	0,97	178	3,8	0,75	0,75	131	2,1			
ComfortAir HD3 ECM 4	10	770	3,18	2,60	551	29,1	2,82	2,51	490	23,4	2,17	2,17	379	14,6	1,64	1,64	288	8,8			
	7,5	665	2,91	2,34	504	24,8	2,57	2,25	446	19,8	1,98	1,98	344	12,3	1,49	1,49	259	7,3			
	5	550	2,58	2,03	447	19,9	2,28	1,95	395	15,9	1,74	1,74	302	9,7	1,30	1,30	226	5,7			
	3	465	2,31	1,79	399	16,2	2,03	1,70	351	12,9	1,54	1,54	268	7,8	1,15	1,15	199	4,6			
	1	375	1,99	1,51	343	12,4	1,75	1,43	302	9,8	1,32	1,29	229	5,9	0,97	0,97	169	3,4			

WT: Water temperature  
Vdc: Inverter speed signal (Vdc)  
Qv: Air flow  
Pc: Cooling total emission  
Ps: Cooling sensible emission  
Qw: Water flow rate  
Dp(c): Dp Cooling

**HEATING EMISSION**

**Entering air temperature: 20 °C**

Model	Vdc	WT: 70 / 60 °C			WT: 60 / 50 °C			WT: 50 / 40 °C			WT: 50 / 45 °C			WT: 45 / 40 °C			
		Qv m <sup>3</sup> /h	Ph kW	Qw l/h	Dp(h) kPa	Ph kW	Qw l/h	Dp(h) kPa	Ph kW	Qw l/h	Dp(h) kPa	Ph kW	Qw l/h	Dp(h) kPa	Ph kW	Qw l/h	Dp(h) kPa
ComfortAir HD3 ECM 0	10	415	4,75	409	11,7	3,67	316	7,6	2,58	222	4,2	2,89	497	17,6	2,35	405	12,4
	7,5	340	4,22	363	9,4	3,26	281	6,1	2,30	198	3,4	2,56	441	14,2	2,09	359	10,0
	5	290	3,59	309	7,0	2,79	240	4,6	1,97	169	2,6	2,18	375	10,6	1,78	306	7,5
	3	230	3,04	261	5,3	2,35	202	3,4	1,66	142	1,7	1,85	319	7,7	1,48	255	5,6
	2	148	2,07	178	2,7	1,60	138	1,7	1,14	98	1,0	1,26	216	4,0	1,05	181	2,8
	1	130	1,84	158	2,0	1,43	123	1,4	1,02	87	0,9	1,12	192	3,3	0,72	124	1,4
ComfortAir HD3 ECM 1	10	415	4,75	409	11,7	3,67	316	7,6	2,58	222	4,2	2,89	497	17,6	2,35	405	12,4
	7,5	355	4,22	363	9,4	3,26	281	6,1	2,30	198	3,4	2,56	441	14,2	2,09	359	10,0
	5	290	3,59	309	7,0	2,79	240	4,6	1,97	169	2,6	2,18	375	10,6	1,78	306	7,5
	3	240	3,08	265	5,3	2,39	206	3,5	1,70	146	2,0	1,87	322	8,1	1,53	263	5,7
	1	190	2,54	219	3,8	1,98	170	2,5	1,41	121	1,4	1,54	265	5,7	1,26	217	4,0
ComfortAir HD3 ECM 2	10	510	5,55	477	15,4	4,28	368	10,0	3,00	258	5,5	3,37	580	23,3	2,74	472	16,3
	7,5	440	4,97	427	12,6	3,83	330	8,2	2,70	232	4,5	3,02	519	19,1	2,46	423	13,4
	5	375	4,40	378	10,1	3,40	293	6,6	2,40	206	3,6	2,67	460	15,3	2,18	375	10,8
	3	315	3,84	330	7,9	2,97	256	5,2	2,10	181	2,9	2,33	401	12,0	1,90	327	8,4
	1	260	3,29	283	6,0	2,55	220	3,9	1,81	156	2,2	2,00	344	9,1	1,63	281	6,4
ComfortAir HD3 ECM 3	10	620	7,19	618	26,9	5,58	480	17,7	3,96	340	9,9	4,36	751	40,6	3,57	614	28,8
	7,5	520	6,27	539	21,1	4,87	419	13,8	3,47	298	7,8	3,81	655	31,8	3,11	536	22,5
	5	420	5,29	455	15,5	4,12	354	10,2	2,94	253	5,8	3,21	553	23,4	2,63	452	16,6
	3	345	4,51	388	11,6	3,52	303	7,7	2,52	216	4,4	2,74	471	17,5	2,24	386	12,5
	1	270	3,68	316	8,1	2,87	247	5,4	2,06	177	3,1	2,23	383	12,1	1,83	315	8,7
ComfortAir HD3 ECM 4	10	770	8,45	727	36,1	6,55	564	23,6	4,64	399	13,1	5,14	884	54,5	4,20	722	38,6
	7,5	665	7,58	652	29,6	5,88	506	19,4	4,17	359	10,8	4,61	792	44,7	3,76	647	31,7
	5	550	6,55	563	22,8	5,09	438	15,0	3,62	311	8,4	3,98	685	34,4	3,26	560	24,4
	3	465	5,74	494	18,0	4,47	384	11,8	3,18	274	6,7	3,49	600	27,1	2,85	491	19,3
	1	375	4,83	415	13,2	3,76	324	8,7	2,69	231	4,9	2,93	504	19,8	2,40	413	14,1

WT: Water temperature  
Vdc: Inverter speed signal (Vdc)  
Qv: Air flow  
Ph: Heating emission  
Qw: Water flow rate  
Dp(h): Dp Heating

## WATER SIDE PRESSURE DROP

### Coil pressure drop

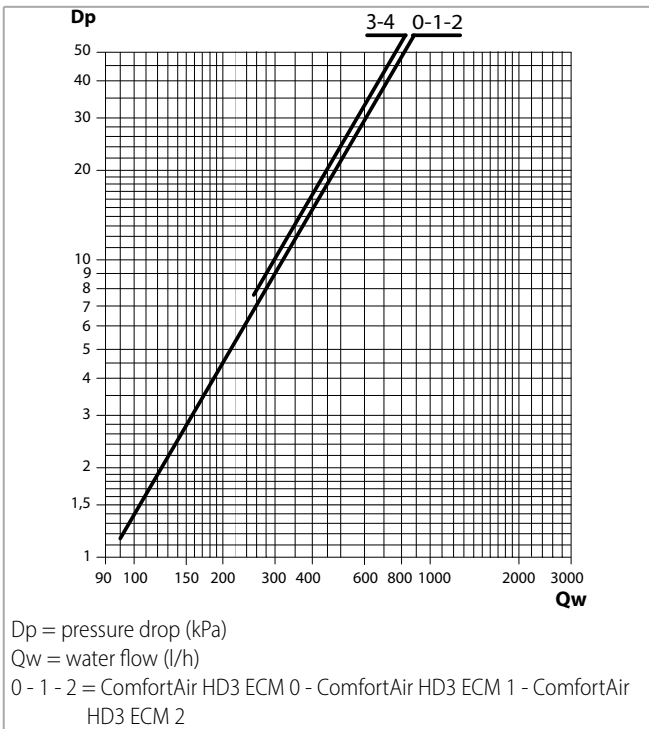

The water pressure drop figures refer to a mean water temperature of 10 °C; for different temperatures, multiply the pressure drop figures by the correction factors K.

K correction factor	Mean water temperature (°C)						
	20	30	40	50	60	70	80
	0,94	0,90	0,86	0,82	0,78	0,74	0,70

### Valves pressure drop

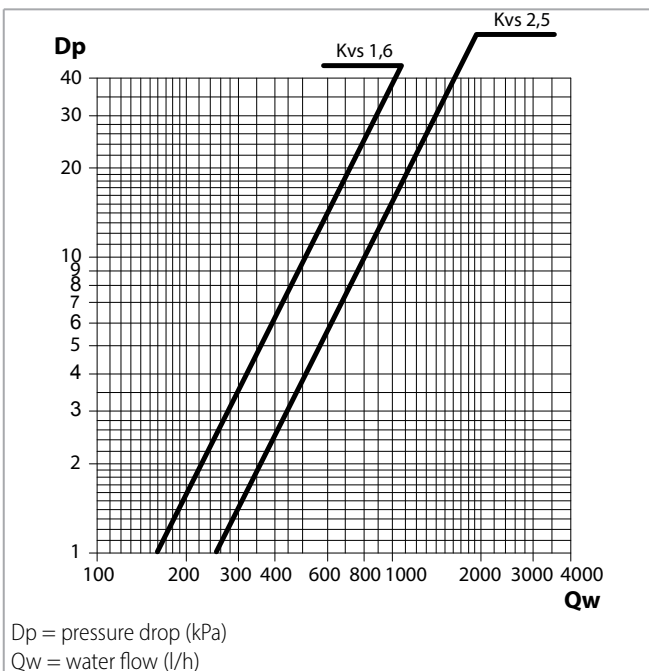

## OPERATION LIMITS

Description		UoM	Value
Water flow	Coil maximum working pressure	bars	10
		kPa	1000
	Lowest water inlet temperature <sup>(1)</sup>	°C	+ 6 °C
	Highest water inlet temperature	°C	+ 70 °C
Power supply	Single-phase rated operating voltage	V/Hz	230/50

(1) for entering water temperatures below +6 °C, contact the technical department

## Installation height

Model		ComfortAir HD3 ECM 0	ComfortAir HD3 ECM 1	ComfortAir HD3 ECM 2	ComfortAir HD3 ECM 3	ComfortAir HD3 ECM 4
Minimum installation height	m			2		
Maximum installation height	m			3		

## Motor electrical data - max. absorption

Model		ComfortAir HD3 ECM 0	ComfortAir HD3 ECM 1	ComfortAir HD3 ECM 2	ComfortAir HD3 ECM 3	ComfortAir HD3 ECM 4
Motor absorption	W	15		21	20	30
Current absorbed	A	0,14		0,19	0,18	0,26





### Packed unit

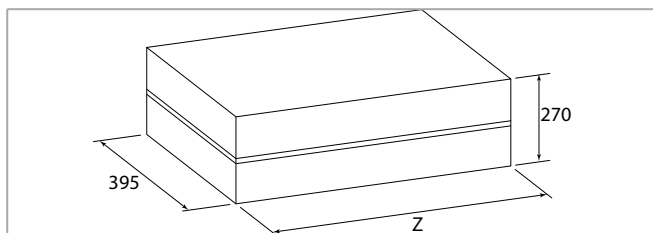

Model	ComfortAir HD3 ECM 0	ComfortAir HD3 ECM 1	ComfortAir HD3 ECM 2	ComfortAir HD3 ECM 3	ComfortAir HD3 ECM 4
Z	mm	950		1255	

### Weight

#### Weight with packaging

Model		ComfortAir HD3 ECM 0	ComfortAir HD3 ECM 1	ComfortAir HD3 ECM 2	ComfortAir HD3 ECM 3	ComfortAir HD3 ECM 4
Weight with packaging without valves	kg	12			16	
Weight with packaging with valves	kg	13			17	

#### Weight without packaging

Model		ComfortAir HD3 ECM 0	ComfortAir HD3 ECM 1	ComfortAir HD3 ECM 2	ComfortAir HD3 ECM 3	ComfortAir HD3 ECM 4
Weight without packaging without valves	kg	10			13	
Weight without packaging with valves	kg	11			14	

### Water content

Model		ComfortAir HD3 ECM 0	ComfortAir HD3 ECM 1	ComfortAir HD3 ECM 2	ComfortAir HD3 ECM 3	ComfortAir HD3 ECM 4
Water content	l	0,9			1,3	

## ELECTRONIC WALL CONTROLS FOR COMFORTAIR HD3 ECM VERSION

### ComfortAir HD3 ECM configuration

For this fan coil configuration, the 1-10 Vdc speed signal, which controls the inverter, must be supplied by a controller with the following signal specifications:

Fan Drive Signal

Fan OFF = 0 Vdc

Fan ON > 1 Vdc

Max. speed = 10 Vdc

ECM Blac inverter board

0÷10 Vdc Circuit Input Impedance Value = 68 kOhm

- **Controls**

The room temperature can be controlled through the **RCFZ** electronic wall thermostat, with different solutions according to every ambient conditions.

The **RCFZ** electronic room thermostat regulates the room temperature precisely and is suitable when the user wants to set the fan speed manually or automatically.

**Note:** all the controls are described in detail in the "Fan Coil Control Range literature".

- Summer/Winter : Manual, centralized, or automatic selection of the summer/winter mode.
  - MODBUS® communication : The ability to connect multiple devices through Modbus RTU interface (via RS485)
- \* The TSMA Control, can be used also with AC motor units.



### TSMA control

ID	Code
TSMA*	LXGFW01X



- Simple installation : Recessed installation on electric box ( standard 503). Parameter configuration is guided, depending on the type of system.
- Fan coil speed : Manual or automatic selection of the fan speed for 3-speed AC motor or an EC motor with 0-10 V control.

## ELECTRIC HEATER

The heater is hermetically sealed and supplied inside the coil pipes and therefore can be only factory mounted.

The electric heaters of the **CFA-ECM** units are single phase 230 V supply.

The electric heater is fitted with a overheat protection. The unit is fitted with two safety thermostats:

- one thermostat with manual reset.
- one thermostat with automatic reset.

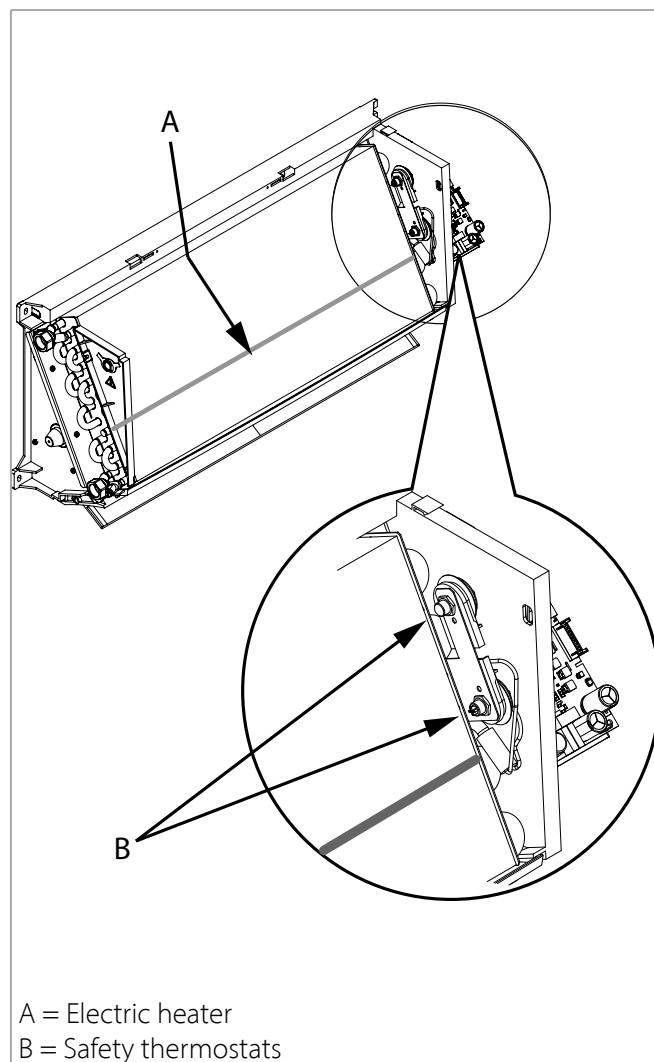

## Constructional features of the main components

Model		ComfortAir HD3 ECM 1	ComfortAir HD3 ECM 2	ComfortAir HD3 ECM 3	ComfortAir HD3 ECM 4
Nominal installed power	W	1000			1500
Maximum current absorbed	A	4,5			7,0
Recommended fuse <sup>(1)</sup>	A	6 <sup>(2)</sup>			8 <sup>(2)</sup>
Power supply	V/ph/Hz	230/1/50			
Connecting wires	n x mm <sup>2</sup>	3 x 1,5			

<sup>(1)</sup> for the overload protection; gG type

<sup>(2)</sup> gG type for overload protection

## Operating limits with electric heater

Max. ambient temperature for CFA-ECM with electric coil in heating mode: 25°C.

## COMMON CONTROLS FOR COMFORTAIR HD3 / COMFORTAIR HD3 ECM

All the **CFA** and the **CFA-ECM** units can be supplied in the **TA version** and in the **MBA version**.

The **TA version** includes the infra-red remote control, that allows the management of one single unit (the basic units can not be networked); for the **TA version** it is available the (optional) Kit "**High Wall Connectivity Kit**" cod. 9025304, that consists of an electronic board for the ModBus communication, that allows the management of one single unit or one or more groups of units by using the Modbus RTU - RS 485 communication protocol.

The **MBA version** is equipped with an auxiliary board that allows to connect the **DS65** wall control (optional) and with a board for the ModBus communication that allows to manage one single unit or one or more groups of units by using the Modbus RTU - RS 485 communication protocol.

The groups of units can be managed according to the Master/Slave logic (up to 20 units) or by supervisory components.

The following devices can be connected to this system:

- The **DS65** wall control for the management of the single units;
- the **PSM-DI** multifunctional panel, the **NET** supervisory system, the **T-DI** Touch screen multifunction control panel and the **Web gateway** for Cloud, to manage one single unit or several units.

**Note:** all the controls and their features are described in detail in the "Fan Coil Control Range Literature".

All the **CFA-TA** e **CFA-MBA** (\*) offer moreover the possibility of management via "**FANCOIL BLE**" APP. This makes this fan coil unit the ideal solution for the air-conditioning of all residential ambients.

### Warning:

for the pairing of the units to the APP it is necessary to have the **RS-F** receiver board fitted by default on the **TA version**, optional accessory for the **MBA version**.

The electronic board fitted on the unit is equipped with a microprocessor with BLE feature, that allows to control at distance or remotely all the units installed.

With the BLE technology it is possible to manage all the fan coil operation modes.

It is moreover possible to manage each single unit or to create some groups; a weekly program can be created by setting, for each day of the week, until four different operation modes.

### FANCOIL BLE



FANCOIL BLE is the new App for Android™ and iOS® systems to set, manage and control Your climatisation system via Bluetooth Low Energy (BLE)® transmission. Free and easy to configure and use, it needs only a smartphone with a Bluetooth® connection (version 4.0 or later versions).

Our "**FANCOIL BLE**" APP is compatible with iOS® and Android™ systems.



## Controls

### DC65 control



## Controls for TS versions

### IRSP remote control



Available from April 2025



**ACCESSORIES**

**PCF condensate drain pump**



Model	FITTED		NOT FITTED	
	ID	Code	ID	Code
0 ÷ 4	PCF-M	9025319	PCF-S	9025309

Height for flow (vertical)	Water flow (l/h) depending on the length of horizontal flow	
	5 m	10 m
0	7,6	7,2
1	7,6	7,2
2	5,6	5,2
3	4,0	3,7
4	3,2	2,9

**FV3S 3 way valves**

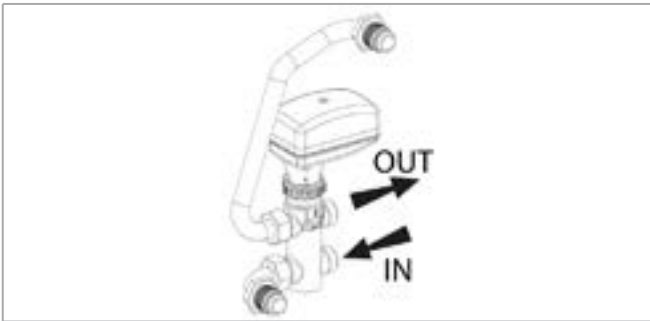

Model	DN	Valve		Not Fitted	
		(Ø)	Kvs	ID	Code
0-1-2	15	1/2"	1,6	FV3S 1-2	9025321
3-4	20	3/4"	2,5	FV3S 3-4	9025323

For the water side pressure drop diagrams, see at p. 12 or p. 25

**FV2S 2 way valve**

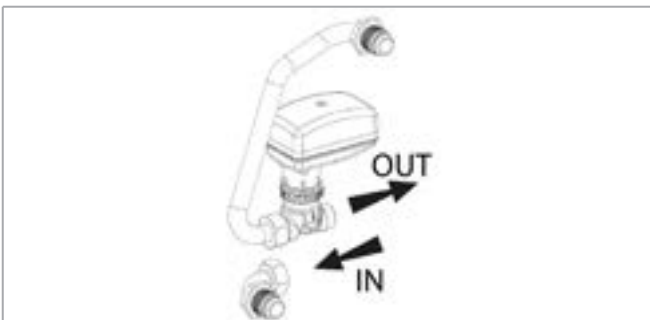

Model	DN	Valve		Not Fitted	
		(Ø)	Kvs	ID	Code
0-1-2	15	1/2"	1,6	FV2S 1-2	9025311
3-4	20	3/4"	2,5	FV2S 3-4	9025313

For the water side pressure drop diagrams, see at p. 12 or p. 25

## Balancing valves independent from the system pressure

- The balancing valve and a combined 2 way valve allow the regulation of the water flow value autonomously, regardless of the system pressure, and the control of the flow by using an ON/OFF electro-thermal actuator.
- The balancing valve allows you to balance the hydraulic system by supplying the required water flow, for each fan-coil, and to maintain it even under partial load conditions.

### Valve operation logic

- "p1" the valve inlet pressure.
- "p3" the outlet pressure.
- "p2" the diaphragm activation pressure, which allows differential pressure "p2" – "p3" to be maintained at a constant value, in order to guarantee the water to flow at the set value.

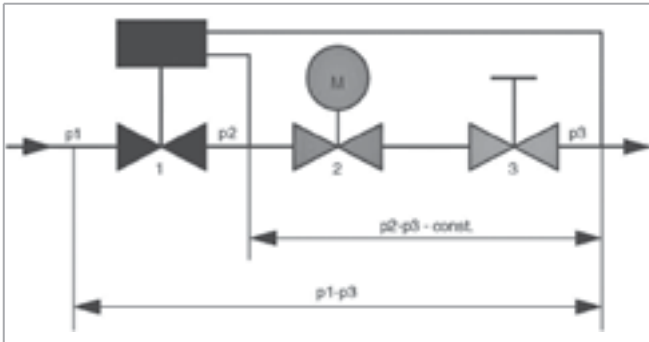

The minimum differential pressure "p1" – "p3", required to guarantee the correct value of the set water flow rate, is indicated in the diagrams and in the related tables. This is an essential factor to size the system pressure drop and pump pressure head. The flow rate is kept at a constant value only if the valve pressure drop is higher than the indicated value.

### Minimum operating differential pressure

The minimum differential pressure and the balancing valve pressure drop must be considered to size the system pumps.

Flow rate is constant if the pressure drop is higher than that indicated in the diagrams and into the related tables.

The following diagram shows an example of the flow rate trend according to the pressure drop and calibration required.

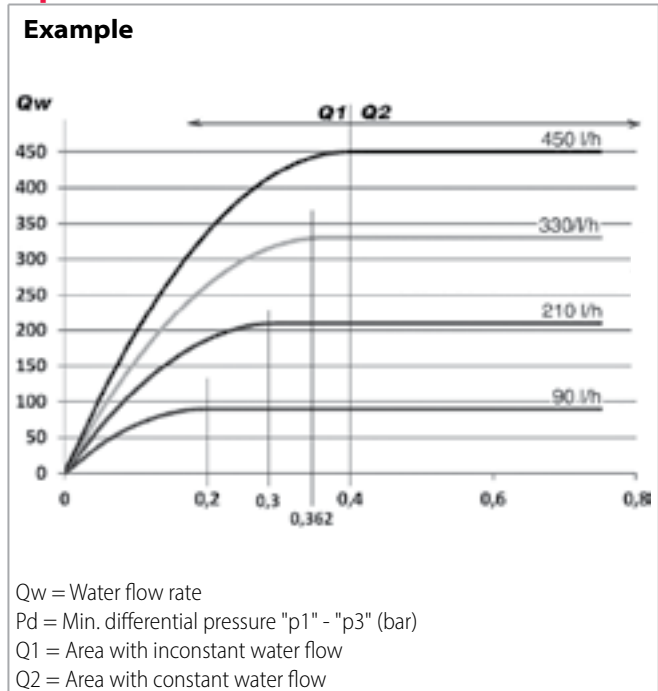

**KIF wall or concealed installation kit**

Model	ID	Code
0-1-2	KIF 1-2	9025191
3-4	KIF 3-4	9025193

Wall or concealed installation kit to be used as an installation template or in case the right connections are previously designed (the units are provided only with left connections).

The technical space within the frame allows to unit the right connections of the installation and the left connections of the unit.

Two variants are available:

- Recessed box installation.
- Wall installation with aesthetic frame.

In the first case the frame is recessed, whereas in the second case it fits the unit esthetically.

The aesthetic frame characteristics are:

- Galvanized steel painted RAL 9003
- Pre-drilled panels for cables and ductworks
- Internal insulation.



**Dimensions**

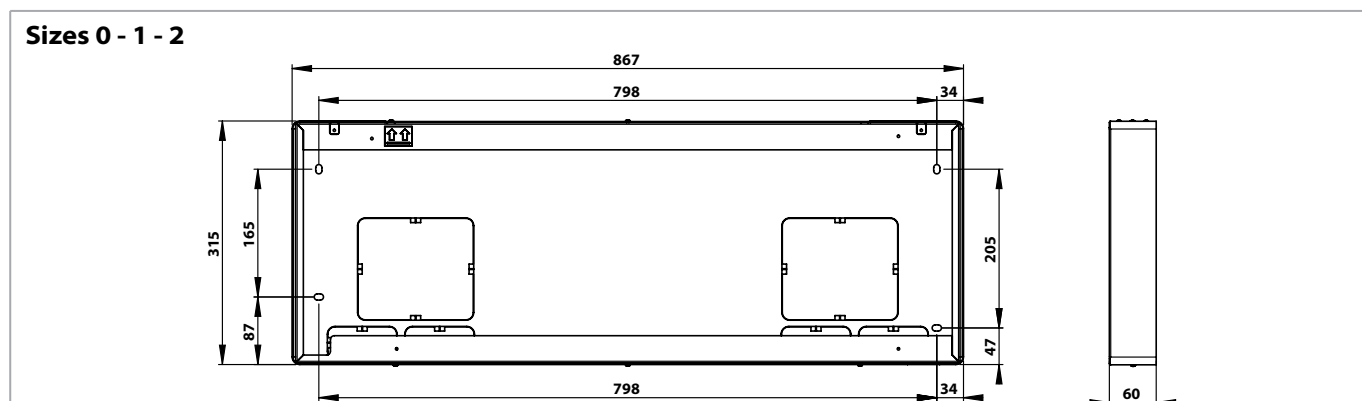

Sizes 3 - 4

