



# ARMONIA ARMONIA ECM

Cassette Fan Coil Unit



## Application guide

### INTRODUCTION

The Cassette fan coil units **ARMONIA** serie (7 sizes), **ARMONIA ECM** serie (5 sizes) and **ARMONIA ECM 7-8** (2 sizes), are the result of an extended technical and design development aimed at achieving the highest level in terms of performance, silent operation and control possibility.

All range is compliant with the **Regulation (EU) No. 327/2011** which requires **very low electric consumption ratings** in relation to performances provided.

The full ARMONIA range has an innovative and beautiful design, high control flexibility and extremely easy maintenance, all this achieving the highest level in terms of performance suited to all dimension environments.

The air diffuser has an highly attractive aesthetical appearance, very innovative, and is also able to offer the best air distribution performance thanks to long computer studies and laboratory tests.

The standard colour is RAL 9003, other colours available on request.

All the models allow the best outcome in terms of quietness and of price/performance ratio.

Every unit can be supplied with 1 coil (2 pipe system) and a possible electric heater or with 2 coils (4 pipe system).

The Cassette is fitted with inlets for fresh air to be mixed with return air inside the unit.

The float switch centrifugal pump is particularly silent, with 650 mm of maximum head.

In addition to temperature and speed standard controls, automatic speed selection is also available. More than one unit can be connected to a single control.

All the units can be supplied in **MB** version. This version includes a wide range of controls, including the infra-red remote control, which allows managing one single unit or one or more groups of units by using the Modbus RTU - RS 485 communication protocol. The units can be connected to the most common automatic building management systems.

**With the ARMONIA ECM 7-8 MB version serie it is possible to control at the same time the (motorized) outlet louvers with the remote-control or with the DC65 wall control.**

The outlet louvers position themselves automatically according to the selected operation (summer-winter) and can be managed with the swing mode, that guarantees a complete air distribution in the environment.

### ECM version

The **ARMONIA ECM** and **ARMONIA ECM 7-8** series use an innovative brushless synchronous permanent magnet electric motor controlled by an inverter board that is directly installed on the unit.

The air flow can be varied continuously with a 1-10 V signal from controls or by independent controllers (programmable controllers with a 1-10 V output).

The extreme efficiency, also at a low speed, makes possible a great reduction in electric consumption (more than 75% less in comparison to a traditional motor) with absorption values, under normal operating conditions, that are no greater than a 10 Watt for **ARMONIA ECM** serie and than 20 Watt for **ARMONIA ECM 7-8** serie.

The brushless motor is characterised by a constant synchronous speed, independently of the applied load, that depends only on the motor power supply frequency, which is modulated by the inverter.

It consumes less because:

- the motor always works at its point of maximum efficiency
- in the brushless motor, the rotor's permanent magnets generate the magnetising power autonomously
- the motor always operates at the synchronous speed, as a result there are no induced currents that reduce efficiency.

The main advantages are:

- large reduction in energy consumption, thanks to an optimal response to the thermal load of the environment during every moment of the day
- operating silence at all rotation speeds
- ability to operate at any rotation speed.

## CONSTRUCTION FEATURES

**600 x 600 version**



**800 x 800 version**



### Air diffuser

Intake grids, frame and adjustable air distribution louvers on each side, made from ABS.

- Several Versions are available as options:
- PLASTIC DIFFUSER - WHITE - NOT FITTED
- PLASTIC DIFFUSER WITHOUT MOTORIZED FLAPS - WHITE - NOT FITTED
- PLASTIC DIFFUSER WITH MOTORIZED FLAPS - WHITE - NOT FITTED
- METALLIC DIFFUSER - WHITE - NOT FITTED
- PLASTIC DIFFUSER IN DIFFERENT RAL COLOURS (Min. qty 20 pcs)
- PLASTIC DIFFUSER IN DIFFERENT RAL COLOURS WITHOUT MOTORIZED FLAPS (Min. qty 20 pcs)
- PLASTIC DIFFUSER IN DIFFERENT RAL COLOURS WITH MOTORIZED FLAPS (Min. qty 20 pcs)

### Inner casing

It is made of galvanized steel with internal thermal insulation with polyolefin (PO) foam (B-s2-d0 EN 13501-01) and external anti-condensate lining.

### Control devices

Made of an external box with the control electronic board with an easily accessible terminal board.

### Fan assembly

The fan assembly, which is mounted on anti-vibrating supports, is extremely silent.

The radial fan has been designed to optimise performance, using wing profile blades with a shape that reduces turbulence, increasing efficiency and reducing noise.

The motor is single phase 230 V / 50 Hz supply, class B insulation and integrated Klixon thermal contact for motor protection.

The units are supplied with 3 standard speeds connected and it is possible to change them on site if necessary.

### Coil

Made of copper tubes with bonded aluminium fins for maximum transfer contact.

1, 2 or 3 row coil for 2 pipe models and 2+1 row coil for 4 pipe models (the heating row is on the inside part of the coil).

For 4 pipe systems two versions are available: the ARMONIA 040 ARMONIA 140 ARMONIA 240 ARMONIA 340 ARMONIA 440 ARMONIA 540 ARMONIA 640 serie supply an higher heating emission; and the ARMONIA 260 ARMONIA 360 ARMONIA 560 ARMONIA 660 serie supply an higher cooling emission. The coil is not suitable for use in corrosive atmosphere or in environments where aluminium may be subject to corrosion.

### Condensate collection tray

High density ABS polystyrene foam condensate tray, shaped in order to optimize the air diffusion. Fire retardant rating B1 to DIN 4102.

### Filter

Synthetic washable filter, easily removable.

### Condensate drain pump

Float switch centrifugal pump with 650 mm of maximum head, integral to the unit and wired to the control panel on the outside of the casing.

The version with available pressure 1000 mm can be supplied on demand.

### Valve set

Two or three way valves for ON/OFF operation, with pipe mounting kit and lockshields.

## TECHNICAL FEATURES

### 2 pipe system

The following standard rating conditions are used:

#### COOLING

Entering air temperature: + 27 °C d.b. + 19 °C w.b.  
Water temperature: +7 °C E.W.T. +12 °C L.W.T.

#### HEATING

Entering air temperature: + 20 °C  
Water temperature: +45 °C E.W.T. +40 °C L.W.T.

MODEL	Speed	ARMONIA 020			ARMONIA 120			ARMONIA 220			ARMONIA 320		
		1	2	3	1	2	3	1	2	3	1	2	3
Air flow	m <sup>3</sup> /h	310	420	610	310	420	520	320	500	710	430	610	880
Cooling total emission	kW	1,25	1,60	1,92	1,82	2,31	2,64	2,23	3,30	4,26	2,91	3,82	4,93
Cooling sensible emission	kW	0,99	1,29	1,58	1,33	1,72	2,00	1,55	2,35	3,11	2,05	2,75	3,65
Heating emission	kW	1,38	1,80	2,24	1,85	2,42	2,80	2,12	3,28	4,37	2,85	3,85	5,15
Dp Cooling	kPa	4,5	7,0	10,0	4,9	7,6	9,7	6,4	13,0	20,9	7,5	12,4	19,7
Dp Heating	kPa	4,4	7,2	10,7	4,3	6,9	9,0	2,8	6,1	10,2	6,2	10,6	17,8
Sound power (Lw)	dB(A)	33	40	49	33	40	45	33	45	53	41	49	59
Sound pressure (Lp) <sup>(1)</sup>	dB(A)	24	31	40	24	31	36	24	36	44	32	40	50
Fan	W	25	32	57	25	32	44	25	44	68	32	57	90
Current absorbed	A	0,11	0,15	0,27	0,11	0,15	0,20	0,11	0,20	0,32	0,15	0,27	0,45
Condensate drain pump power absorption	W	10	10	10	10	10	10	10	10	10	10	10	10
Water content	l	0,8	0,8	0,8	1,4	1,4	1,4	2,1	2,1	2,1	2,1	2,1	2,1
Length	mm	575	575	575	575	575	575	575	575	575	575	575	575
Depth	mm	575	575	575	575	575	575	575	575	575	575	575	575
Height	mm	275	275	275	275	275	275	275	275	275	275	275	275

MODEL	Speed	ARMONIA 420			ARMONIA 520			ARMONIA 620		
		1	2	3	1	2	3	1	2	3
Air flow	m <sup>3</sup> /h	630	820	1140	710	970	1500	710	1280	1820
Cooling total emission	kW	4,18	4,86	6,08	5,27	6,72	9,39	5,27	8,36	10,93
Cooling sensible emission	kW	3,00	3,53	4,51	3,42	4,42	6,36	3,67	6,00	8,08
Heating emission	kW	4,27	5,03	6,50	4,92	6,40	9,23	5,12	8,55	11,72
Dp Cooling	kPa	10,9	14,3	21,6	9,4	14,7	26,9	9,4	21,8	35,6
Dp Heating	kPa	7,0	9,4	15,0	7,1	11,4	22,0	7,6	19,2	33,8
Sound power (Lw)	dB(A)	33	40	48	34	40	53	34	48	58
Sound pressure (Lp) <sup>(1)</sup>	dB(A)	24	31	39	25	31	44	25	39	49
Fan	W	33	48	77	42	63	120	42	95	170
Current absorbed	A	0,15	0,23	0,36	0,18	0,28	0,53	0,18	0,42	0,74
Condensate drain pump power absorption	W	10	10	10	10	10	10	10	10	10
Water content	l	3,0	3,0	3,0	4,0	4,0	4,0	4,0	4,0	4,0
Length	mm	820	820	820	820	820	820	820	820	820
Depth	mm	820	820	820	820	820	820	820	820	820
Height	mm	303	303	303	303	303	303	303	303	303

<sup>(1)</sup> The sound pressure levels are 9 dB (A) lower than the sound power levels, apply to the reverberant field of a 100 m<sup>3</sup> room and a reverberation time of 0.5 sec.

## 4 pipe system

The following standard rating conditions are used:

### COOLING

Entering air temperature: + 27 °C d.b. + 19 °C w.b.  
Water temperature: +7 °C E.W.T. +12 °C L.W.T.

### HEATING

Entering air temperature: + 20 °C  
Water temperature: +65 °C E.W.T. +55 °C L.W.T.

MODEL	Speed	ARMONIA 040			ARMONIA 140			ARMONIA 240			ARMONIA 260			ARMONIA 340			ARMONIA 360		
		1	2	3	1	2	3	1	2	3	1	2	3	1	2	3	1	2	3
Air flow	m <sup>3</sup> /h	310	420	610	310	420	520	320	500	710	320	500	710	430	610	880	430	610	880
Cooling total emission	kW	1,49	1,93	2,27	1,83	2,33	2,66	1,83	2,61	3,27	2,07	3,02	3,86	2,33	2,96	3,72	2,69	3,47	4,44
Cooling sensible emission	kW	1,13	1,52	1,84	1,32	1,68	1,94	1,32	1,94	2,49	1,47	2,20	2,88	1,72	2,23	2,88	1,94	2,56	3,37
Heating emission	kW	1,72	2,23	2,66	2,13	2,66	3,04	2,13	3,04	3,86	1,73	2,71	2,91	2,61	3,33	4,19	2,14	2,66	3,29
Dp Cooling	kPa	6,0	10,0	13,5	4,6	6,9	8,8	4,6	8,8	13,4	4,0	7,0	10,5	7,2	11,2	17,0	6,0	9,0	14,0
Dp Heating	kPa	5,2	8,3	11,4	4,6	6,8	8,7	4,6	8,7	13,3	2,6	4,6	6,7	6,4	9,9	15,0	3,9	5,7	8,4
Sound power (Lw)	dB(A)	33	40	49	33	40	45	33	45	53	33	45	53	41	49	59	41	49	59
Sound pressure (Lp) <sup>(1)</sup>	dB(A)	24	31	40	24	31	36	24	36	44	24	36	44	32	40	50	32	40	50
Fan	W	25	32	57	25	32	44	25	44	68	25	44	68	32	57	90	32	57	90
Current absorbed	A	0,11	0,15	0,27	0,11	0,15	0,20	0,11	0,20	0,32	0,11	0,20	0,32	0,15	0,27	0,45	0,15	0,27	0,45
Condensate drain pump power absorption	W	10	10	10	10	10	10	10	10	10	10	10	10	10	10	10	10	10	10
Cooling water content	l	1,0	1,0	1,0	1,4	1,4	1,4	1,4	1,4	1,4	1,7	1,7	1,7	1,4	1,4	1,4	1,7	1,7	1,7
Heating water content	l	0,6	0,6	0,6	0,7	0,7	0,7	0,7	0,7	0,7	0,5	0,5	0,5	0,7	0,7	0,7	0,5	0,5	0,5
Length	mm	575	575	575	575	575	575	575	575	575	575	575	575	575	575	575	575	575	575
Depth	mm	575	575	575	575	575	575	575	575	575	575	575	575	575	575	575	575	575	575
Height	mm	275	275	275	275	275	275	275	275	275	275	275	275	275	275	275	275	275	275

MODEL	Speed	ARMONIA 440			ARMONIA 540			ARMONIA 560			ARMONIA 640			ARMONIA 660		
		1	2	3	1	2	3	1	2	3	1	2	3	1	2	3
Air flow	m <sup>3</sup> /h	630	820	1140	710	970	1500	710	970	1500	710	1280	1820	710	1280	1820
Cooling total emission	kW	4,11	4,98	6,26	4,48	5,60	7,59	4,95	6,27	8,65	4,48	6,84	8,72	4,95	7,75	10,03
Cooling sensible emission	kW	2,93	3,60	4,61	3,21	4,09	5,71	3,49	4,49	6,37	3,21	5,09	6,67	3,49	5,64	7,51
Heating emission	kW	5,21	6,33	8,02	5,69	7,15	9,66	4,59	5,63	7,50	5,69	8,80	11,16	4,59	6,78	8,58
Dp Cooling	kPa	8,8	12,5	18,9	10,3	15,4	26,9	9,0	14,0	25,0	10,3	22,1	34,7	9,0	20,0	32,0
Dp Heating	kPa	7,9	11,2	17,2	9,3	14,0	24,0	4,9	7,0	11,8	9,3	20,3	31,2	4,9	9,9	15,0
Sound power (Lw)	dB(A)	33	40	48	34	40	53	34	40	53	34	48	58	34	48	58
Sound pressure (Lp) <sup>(1)</sup>	dB(A)	24	31	39	25	31	44	25	31	44	25	39	49	25	39	49
Fan	W	33	48	77	42	63	120	42	63	120	42	95	170	42	95	170
Current absorbed	A	0,15	0,23	0,36	0,18	0,28	0,53	0,18	0,28	0,53	0,18	0,42	0,74	0,18	0,42	0,74
Condensate drain pump power absorption	W	10	10	10	10	10	10	10	10	10	10	10	10	10	10	10
Cooling water content	l	3,0	3,0	3,0	3,0	3,0	3,0	3,6	3,6	3,6	3,0	3,0	3,0	3,6	3,6	3,6
Heating water content	l	1,4	1,4	1,4	1,4	1,4	1,4	1,0	1,0	1,0	1,4	1,4	1,4	1,1	1,1	1,1
Length	mm	820	820	820	820	820	820	820	820	820	820	820	820	820	820	820
Depth	mm	820	820	820	820	820	820	820	820	820	820	820	820	820	820	820
Height	mm	303	303	303	303	303	303	303	303	303	303	303	303	303	303	303

<sup>(1)</sup> The sound pressure levels are 9 dB (A) lower than the sound power levels, apply to the reverberant field of a 100 m<sup>3</sup> room and a reverberation time of 0.5 sec.

**COOLING EMISSION**

**Models with single coil (2 pipe installations)**

**Entering air temperature: +27 °C d.b. – +19 °C w.b.**

Model	Vn	Qv m³/h	WT: 7 / 12 °C			WT: 8 / 13 °C			WT: 9 / 14 °C			WT: 12 / 17 °C		
			Pc kW	Ps kW	Qw l/h	Pc kW	Ps kW	Qw l/h	Pc kW	Ps kW	Qw l/h	Pc kW	Ps kW	Qw l/h
ARMONIA 020	3 MAX	610	1,92	1,58	340	1,75	1,50	310	1,41	1,39	254	1,10	1,10	199
	2 MED	420	1,60	1,29	280	1,42	1,19	250	1,22	1,16	210	0,90	0,90	160
	1 MIN	310	1,25	0,99	219	1,09	0,88	191	0,96	0,89	165	0,69	0,69	123
ARMONIA 120	3 MAX	520	2,64	2,00	462	2,34	1,82	409	2,10	1,75	362	1,43	1,43	252
	2 MED	420	2,31	1,72	403	2,05	1,58	358	1,84	1,50	317	1,25	1,25	220
	1 MIN	310	1,82	1,30	317	1,62	1,22	282	1,61	1,29	276	1,07	1,07	188
ARMONIA 220	3 MAX	710	4,26	3,11	745	3,81	2,87	668	3,59	2,87	617	2,37	2,37	420
	2 MED	500	3,30	2,35	575	2,97	2,18	518	2,81	2,18	483	1,82	1,82	319
	1 MIN	320	2,23	1,55	387	2,01	1,43	350	2,03	1,53	349	1,29	1,29	225
ARMONIA 320	3 MAX	880	4,93	3,65	863	4,38	3,35	769	4,03	3,29	694	2,70	2,70	479
	2 MED	610	3,82	2,75	667	3,44	2,55	601	3,25	2,57	559	2,13	2,13	376
	1 MIN	430	2,91	2,05	506	2,62	1,90	456	2,50	1,92	430	1,62	1,62	283
ARMONIA 420	3 MAX	1140	6,08	4,40	1060	5,39	4,14	940	4,88	3,95	840	3,25	3,25	573
	2 MED	820	4,86	3,45	845	4,33	3,25	753	3,92	3,09	674	2,58	2,58	453
	1 MIN	630	4,18	2,94	722	3,73	2,76	647	3,37	2,62	580	2,20	2,20	384
ARMONIA 520	3 MAX	1500	9,39	6,36	1635	8,48	6,33	1480	7,57	5,99	1301	5,00	5,00	880
	2 MED	970	6,72	4,42	1166	6,10	4,41	1060	5,46	4,15	939	3,50	3,50	612
	1 MIN	710	5,27	3,42	913	4,79	3,40	830	4,30	3,20	740	2,48	2,48	434
ARMONIA 620	3 MAX	1820	10,93	7,90	1909	9,83	7,48	1721	8,78	7,11	1511	5,90	5,90	1044
	2 MED	1280	8,36	5,89	1454	7,59	5,59	1321	6,75	5,27	1162	4,42	4,42	775
	1 MIN	710	5,27	3,60	913	4,79	3,40	830	4,30	3,20	740	2,48	2,48	434

WT: Water temperature  
 Vn: Nominal speeds  
 Qv: Air flow  
 Pc: Cooling total emission  
 Ps: Cooling sensible emission  
 Qw: Water flow rate

## Models with double coil (4 pipe installations)

Note: the ARMONIA 260 360 560 660 versions are equipped with an extra cold battery.

Entering air temperature: +27 °C d.b. – +19 °C w.b.

Model	Vn	Qv m <sup>3</sup> /h	WT: 7 / 12 °C			WT: 8 / 13 °C			WT: 9 / 14 °C			WT: 12 / 17 °C			
			Pc kW	Ps kW	Qw l/h	Pc kW	Ps kW	Qw l/h	Pc kW	Ps kW	Qw l/h	Pc kW	Ps kW	Qw l/h	
ARMONIA 040	3	MAX	610	2,27	1,84	401	2,04	1,73	361	1,78	1,69	307	1,33	1,33	239
	2	MED	420	1,93	1,52	337	1,73	1,43	303	1,51	1,37	260	1,11	1,11	196
	1	MIN	310	1,49	1,13	260	1,34	1,06	234	1,17	1,02	201	0,84	0,84	148
ARMONIA 140	3	MAX	520	2,66	1,94	465	2,36	1,82	413	2,18	1,79	374	1,47	1,47	260
	2	MED	420	2,33	1,68	405	2,06	1,57	360	1,80	1,44	309	1,19	1,19	210
	1	MIN	310	1,83	1,32	318	1,63	1,21	284	1,55	1,22	267	1,01	1,01	177
ARMONIA 240	3	MAX	710	3,27	2,49	574	2,88	2,28	507	2,72	2,30	467	1,85	1,85	330
	2	MED	500	2,61	1,94	455	2,30	1,78	404	2,18	1,79	374	1,47	1,47	260
	1	MIN	320	1,83	1,32	318	1,63	1,21	284	1,55	1,22	267	1,01	1,01	177
ARMONIA 260	3	MAX	710	3,86	2,88	664	3,49	2,70	613	3,00	2,53	528	2,13	2,13	378
	2	MED	500	3,02	2,20	519	2,75	2,06	480	2,37	1,93	415	1,63	1,63	288
	1	MIN	320	2,07	1,47	355	1,89	1,37	329	1,65	1,29	287	1,10	1,10	192
ARMONIA 340	3	MAX	880	3,72	2,88	656	3,25	2,62	574	2,98	2,56	512	2,04	2,04	366
	2	MED	610	2,96	2,23	520	2,62	2,05	461	2,40	2,00	413	1,61	1,61	288
	1	MIN	430	2,33	1,72	405	2,06	1,57	360	1,96	1,59	337	1,32	1,32	231
ARMONIA 360	3	MAX	880	4,44	3,37	764	3,99	3,14	702	3,43	2,96	606	2,48	2,48	442
	2	MED	610	3,47	2,56	597	3,16	2,41	554	2,71	2,25	477	1,90	1,90	337
	1	MIN	430	2,69	1,94	462	2,45	1,82	427	2,12	1,70	370	1,46	1,46	256
ARMONIA 440	3	MAX	1140	6,26	4,50	1090	5,58	4,25	973	5,02	4,04	864	3,33	3,33	586
	2	MED	820	4,98	3,52	866	4,46	3,32	776	4,02	3,15	691	2,63	2,63	462
	1	MIN	630	4,11	2,87	713	3,69	2,71	640	3,33	2,56	572	2,14	2,14	374
ARMONIA 540	3	MAX	1500	7,59	5,57	1327	6,71	5,23	1175	6,08	5,02	1046	4,10	4,10	726
	2	MED	970	5,60	4,00	974	5,00	3,77	871	4,50	3,57	775	2,99	2,99	524
	1	MIN	710	4,48	3,15	778	4,01	2,97	698	3,62	2,81	623	2,35	2,35	411
ARMONIA 560	3	MAX	1500	8,65	6,37	1488	8,05	6,05	1405	6,79	5,60	1189	4,74	4,74	836
	2	MED	970	6,27	4,49	1078	5,86	4,27	1018	4,98	3,94	867	3,35	3,35	587
	1	MIN	710	4,95	3,49	851	4,62	3,31	802	3,96	3,06	689	2,63	2,63	459
ARMONIA 640	3	MAX	1820	8,72	6,49	1529	7,64	6,07	1344	6,97	5,98	1199	4,77	4,77	849
	2	MED	1280	6,84	4,96	1191	6,08	4,67	1062	5,48	4,46	942	3,66	3,66	646
	1	MIN	710	4,48	3,15	778	4,01	2,97	698	3,62	2,81	623	2,35	2,35	411
ARMONIA 660	3	MAX	1820	10,03	7,51	1725	9,28	7,11	1625	7,82	6,60	1375	5,57	5,57	987
	2	MED	1280	7,75	5,64	1332	7,24	5,37	1261	6,11	4,96	1066	4,21	4,21	739
	1	MIN	710	4,95	3,49	851	4,62	3,31	802	3,96	3,06	689	2,63	2,63	459

WT: Water temperature  
Vn: Nominal speeds  
Qv: Air flow  
Pc: Cooling total emission  
Ps: Cooling sensible emission  
Qw: Water flow rate

HEATING EMISSION

Models with single coil (2 pipe installations)

Entering air temperature: +20 °C

Model	Vn	Qv m <sup>3</sup> /h	WT: 80 / 70 °C		WT: 70 / 60 °C		WT: 60 / 50 °C		WT: 50 / 40 °C		WT: 45 / 40 °C	
			Ph kW	Qw l/h	Ph kW	Qw l/h	Ph kW	Qw l/h	Ph kW	Qw l/h	Ph kW	Qw l/h
ARMONIA 020	3 MAX	610	5,67	488	4,56	393	3,46	298	2,37	203	2,24	386
	2 MED	420	4,55	391	3,66	315	2,78	239	1,91	164	1,80	310
	1 MIN	310	3,47	298	2,80	240	2,13	183	1,46	126	1,38	237
ARMONIA 120	3 MAX	520	6,97	599	5,68	488	4,39	377	3,10	266	2,80	482
	2 MED	420	5,96	513	4,91	422	3,80	327	2,69	232	2,42	417
	1 MIN	310	5,12	441	4,19	360	3,25	279	2,31	198	2,07	356
ARMONIA 220	3 MAX	710	11,30	972	9,25	795	7,19	619	5,12	440	4,57	787
	2 MED	500	8,48	730	6,96	598	5,43	467	3,89	334	3,45	593
	1 MIN	320	5,87	505	4,83	415	3,79	326	2,73	235	2,39	412
ARMONIA 320	3 MAX	880	13,00	1118	10,63	914	8,25	709	5,86	504	5,25	903
	2 MED	610	10,07	866	8,25	709	6,42	552	4,58	394	4,08	702
	1 MIN	430	7,43	639	6,10	524	4,77	410	3,42	294	3,02	520
ARMONIA 420	3 MAX	1140	16,08	1383	13,14	1130	10,21	878	7,26	624	6,50	1118
	2 MED	820	12,41	1067	10,16	874	7,92	681	5,65	486	5,03	865
	1 MIN	630	10,50	903	8,61	741	6,72	578	4,82	415	4,27	734
ARMONIA 520	3 MAX	1500	24,08	2071	19,76	1699	15,43	1327	11,06	951	9,78	1683
	2 MED	970	16,32	1403	13,43	1155	10,54	906	7,62	655	6,67	1146
	1 MIN	710	12,42	1068	10,25	882	8,07	694	5,87	505	5,09	876
ARMONIA 620	3 MAX	1820	28,91	2486	23,68	2037	18,45	1586	13,17	1132	11,72	2015
	2 MED	1280	21,01	1807	17,26	1484	13,50	1161	9,70	834	8,55	1471
	1 MIN	710	12,42	1068	10,25	882	8,07	694	5,87	505	5,09	876

WT: Water temperature  
 Vn: Nominal speeds  
 Qv: Air flow  
 Ph: Heating emission  
 Qw: Water flow rate

## Models with double coil (4 pipe installations)

Note: the ARMONIA 260 360 560 660 versions are equipped with an extra cold battery.

Entering air temperature: +20 °C

Model	Vn	Qv m <sup>3</sup> /h	WT: 80 / 70 °C		WT: 70 / 60 °C		WT: 60 / 50 °C		WT: 50 / 40 °C		WT: 45 / 40 °C		
			Ph kW	Qw l/h	Ph kW	Qw l/h	Ph kW	Qw l/h	Ph kW	Qw l/h	Ph kW	Qw l/h	
ARMONIA 040	3	MAX	610	3,78	325	3,03	261	2,29	197	1,56	134	1,49	256
	2	MED	420	3,17	272	2,54	219	1,93	166	1,31	113	1,25	215
	1	MIN	310	2,44	210	1,96	169	1,49	128	1,01	87	0,96	166
ARMONIA 140	3	MAX	520	4,17	358	3,46	298	2,54	218	1,73	149	1,65	283
	2	MED	420	3,63	312	3,02	260	2,22	191	1,51	130	1,44	247
	1	MIN	310	2,87	247	2,43	209	1,76	151	1,20	103	1,14	196
ARMONIA 240	3	MAX	710	5,17	444	4,40	378	3,14	270	2,14	184	2,04	351
	2	MED	500	4,07	350	3,46	298	2,48	214	1,69	146	1,61	277
	1	MIN	320	2,87	247	2,43	209	1,76	151	1,20	103	1,14	196
ARMONIA 260	3	MAX	710	4,22	363	3,35	288	2,48	213	1,61	139	1,62	279
	2	MED	500	3,42	294	2,71	233	2,01	173	1,32	113	1,32	226
	1	MIN	320	2,49	214	1,98	170	1,47	127	0,97	83	0,96	165
ARMONIA 340	3	MAX	880	5,93	510	4,95	426	3,60	310	2,45	211	2,34	402
	2	MED	610	4,67	401	3,97	341	2,84	244	1,94	166	1,84	317
	1	MIN	430	3,63	312	3,10	267	2,22	191	1,51	130	1,44	247
ARMONIA 360	3	MAX	880	4,78	411	3,79	326	2,80	241	1,82	156	1,83	315
	2	MED	610	3,86	332	3,06	263	2,27	195	1,48	127	1,48	255
	1	MIN	430	3,10	266	2,46	212	1,83	157	1,20	103	1,19	205
ARMONIA 440	3	MAX	1140	11,28	970	9,10	783	6,93	596	4,76	410	4,48	771
	2	MED	820	8,90	766	7,19	618	5,48	471	3,77	324	3,54	609
	1	MIN	630	7,31	629	5,91	508	4,51	388	3,11	267	2,91	501
ARMONIA 540	3	MAX	1500	13,60	1170	11,00	946	8,34	718	5,73	493	5,40	929
	2	MED	970	10,04	864	8,10	697	6,17	531	4,25	365	3,99	686
	1	MIN	710	7,98	686	6,45	555	4,92	423	3,39	291	3,18	547
ARMONIA 560	3	MAX	1500	10,69	919	8,56	736	6,44	554	4,33	493	4,18	720
	2	MED	970	8,01	689	6,42	552	4,84	416	3,27	365	3,14	541
	1	MIN	710	6,52	561	5,23	450	3,95	340	2,67	291	2,56	441
ARMONIA 640	3	MAX	1820	15,74	1353	12,70	1092	9,64	829	6,61	569	6,24	1074
	2	MED	1280	12,37	1064	9,98	858	7,60	653	5,22	449	4,91	845
	1	MIN	710	7,98	686	6,45	555	4,92	423	3,39	291	3,18	547
ARMONIA 660	3	MAX	1820	12,24	1053	9,80	843	7,36	633	6,61	569	4,79	824
	2	MED	1280	9,66	831	7,74	666	5,83	501	5,22	449	3,79	651
	1	MIN	710	6,52	561	5,23	450	3,95	340	3,39	291	2,56	441

WT: Water temperature  
Vn: Nominal speeds  
Qv: Air flow  
Ph: Heating emission  
Qw: Water flow rate

**WATER SIDE PRESSURE DROP**

**2 pipe system**

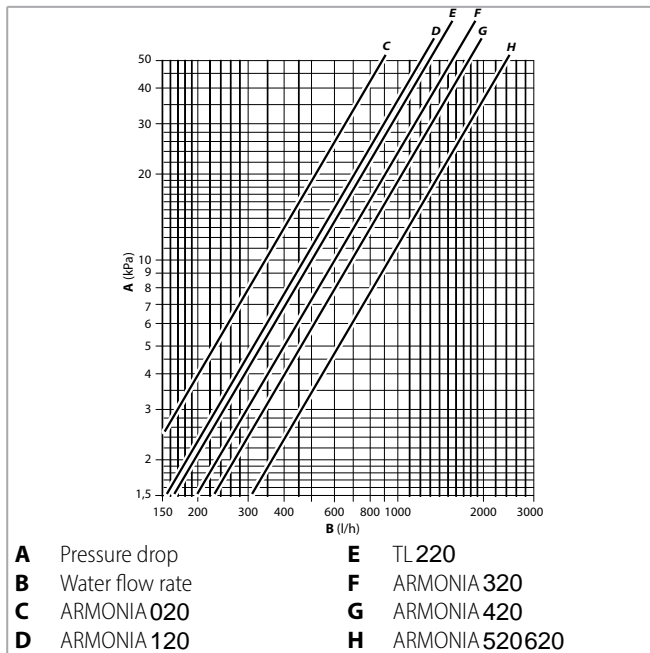

The water pressure drop figures refer to a mean water temperature of 10 °C; for different temperatures, multiply the pressure drop figures by the correction factors K.

	Mean water temperature (°C)						
	20	30	40	50	60	70	80
K correction factor	0,94	0,90	0,86	0,82	0,78	0,74	0,70

**4 pipe system**

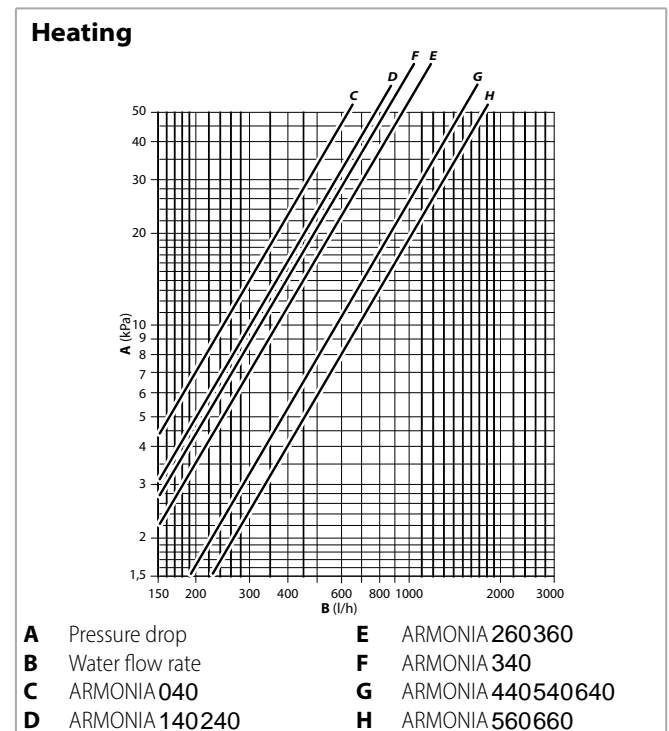
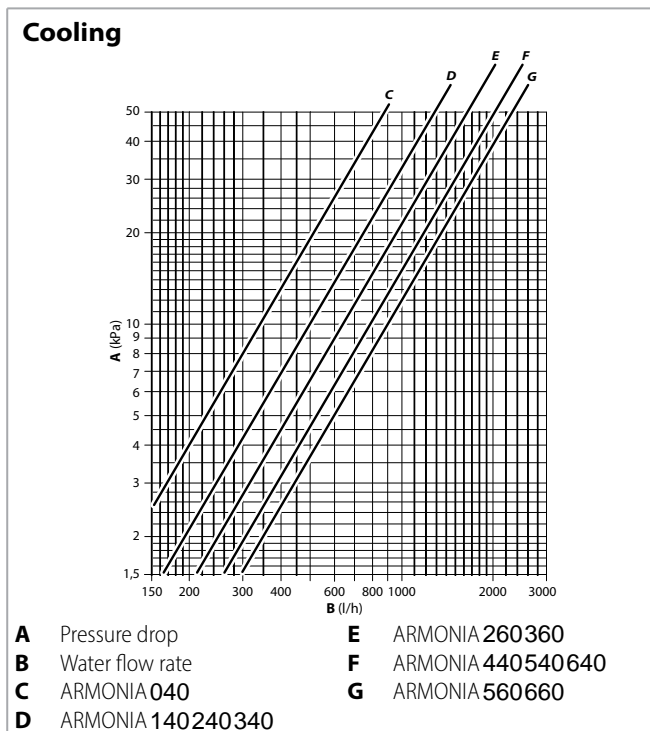

The water pressure drop figures refer to a mean water temperature of 10 °C; for different temperatures, multiply the pressure drop figures by the correction factors K.

	Mean water temperature (°C)						
	20	30	40	50	60	70	80
K correction factor	0,94	0,90	0,86	0,82	0,78	0,74	0,70

The water pressure drop figures refer to a mean water temperature of 60 °C; for different temperatures, multiply the pressure drop figures by the correction factors K.

	Mean water temperature (°C)			
	40	50	70	80
K correction factor	1,12	1,06	0,94	0,88

## OPERATION LIMITS

Description		UoM	Value
Water flow	Max. water side pressure	bars	10
		kPa	1000
	Lowest water inlet temperature	°C	+6
	Highest water inlet temperature	°C	+80
Power supply	Single-phase rated operating voltage	V/Hz	230/50

For maximum installation height, see p. 16.



**DIMENSION AND WEIGHT**

**ARMONIA 020 040 / ARMONIA 120 140 / ARMONIA 220 240 260 / ARMONIA 320 340 3.6T (600 x 600 version)**

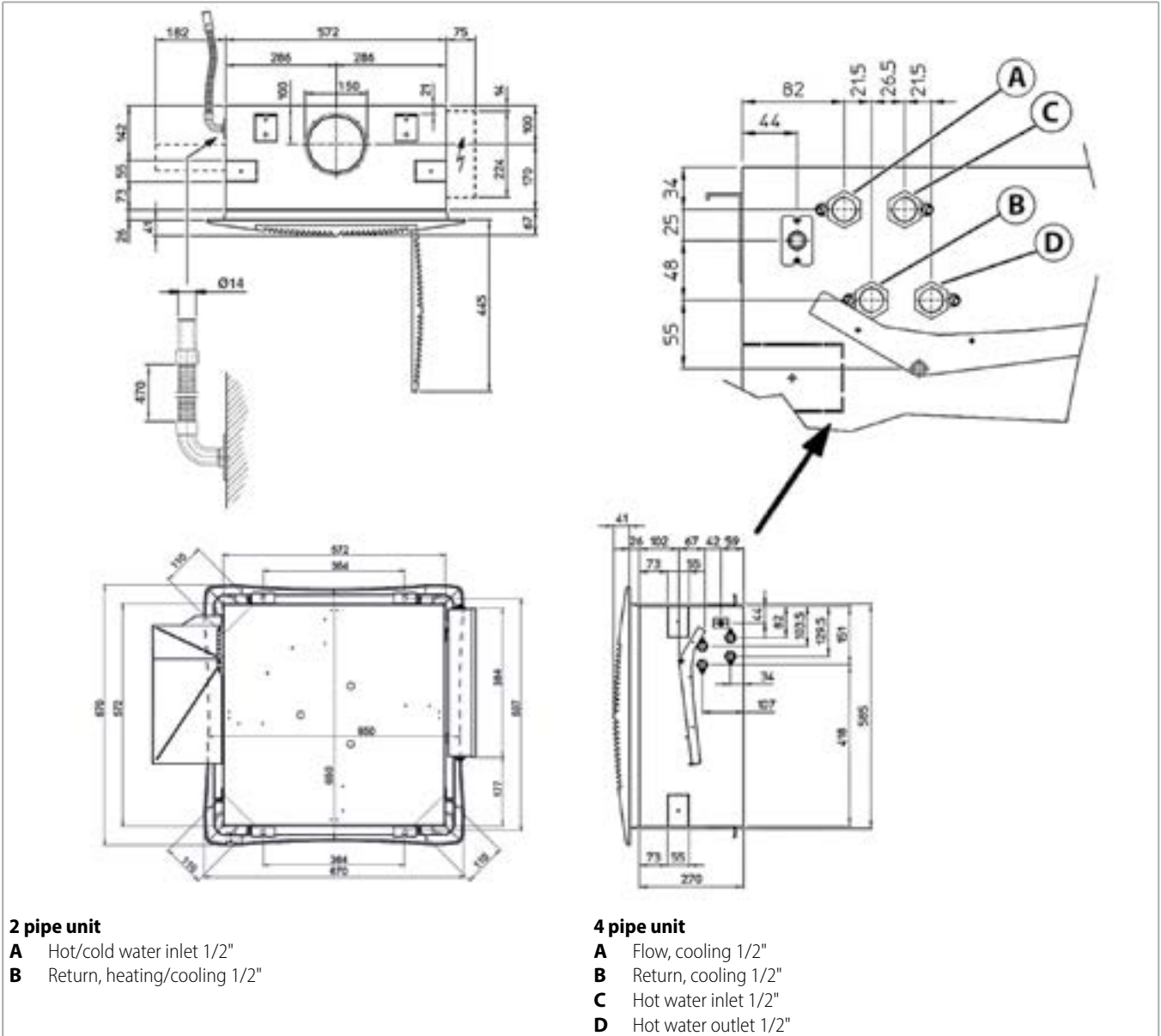

**Packed unit**

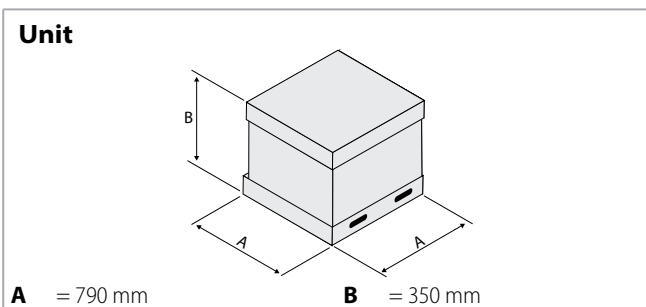

Weight/Model	020 120	040 140	220 240 260	320 340 360
With packaging	kg 21,0	22,5	22,0	
Without packaging	kg 18,0	19,5	19,0	

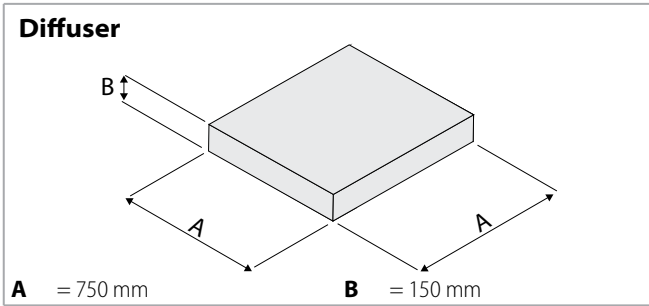

Weight/Model		020 120	040 140	220 240 260	320 340 360
With packaging	kg			3,5	
Without packaging	kg			2,5	

**ARMONIA 420 440 / ARMONIA 520 540 560 / ARMONIA 620 640 660 (800 x 800 version)**

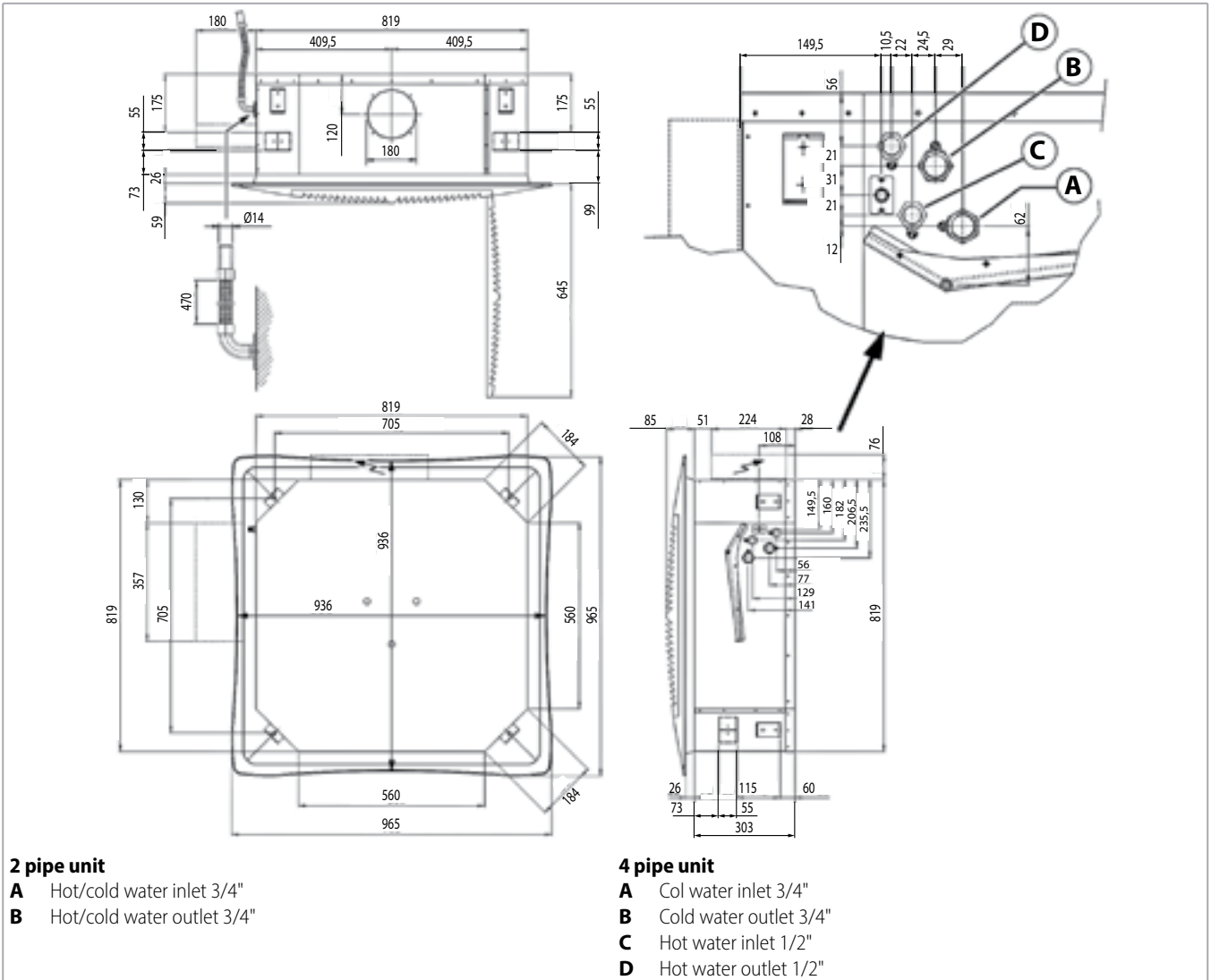

**Packed unit**

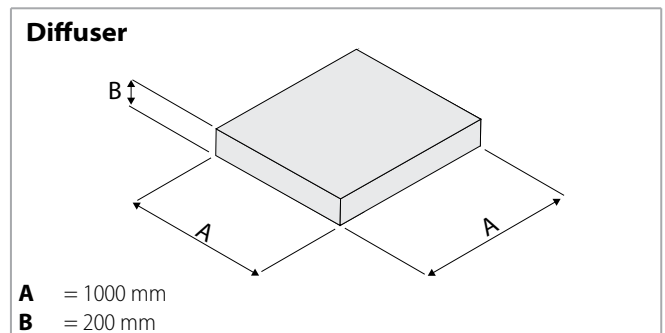
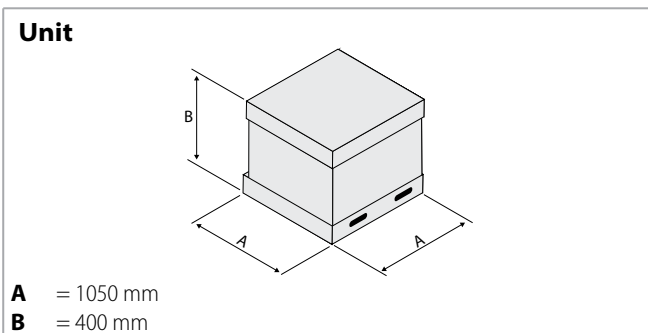

Weight/Model		420	440	520	540	560	620	640	660
With packaging	kg	40				44			
Without packaging	kg	35				39			

Weight/Model		420	440	520	540	560	620	640	660
With packaging	kg					7,0			
Without packaging	kg					5,5			

**Metal air inlet grid MD 600 / MD 800**

(RS receiver, Code 9066338, for metal diffuser for MB units)  
 Not suitable with electronic electrostatic filter.

Model	Code
MD-600	9079420
MD-800	9079417

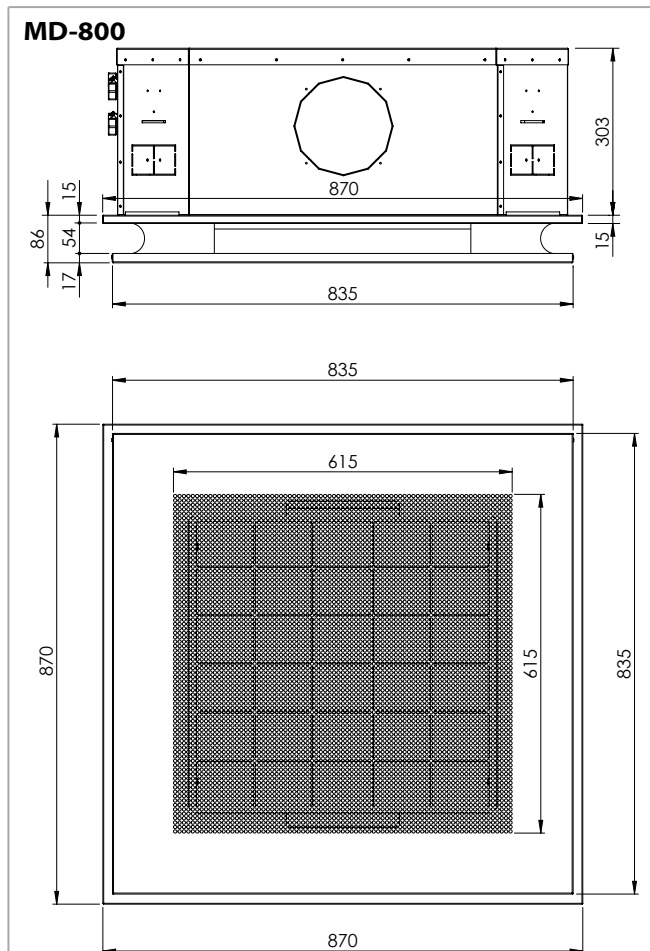
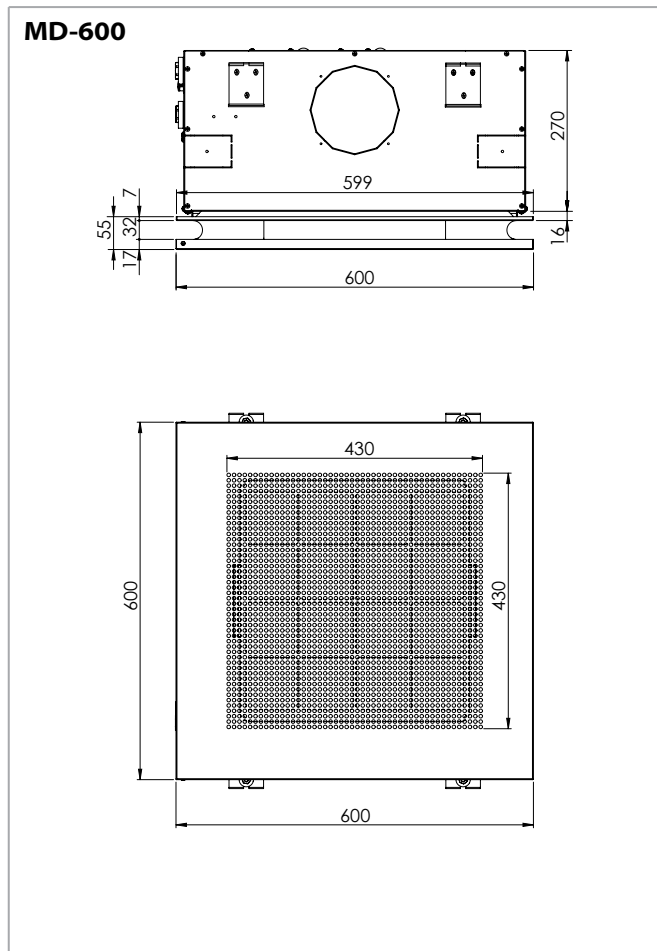

**AIR THROW**

The air throw indicated in the tables must only be considered the maximum value, as it may change significantly in relation to the dimensions of the room in which the appliance is installed and the positioning of the furniture in the room.

The useful throw L refers to the distance between the unit and the point where the air speed is 0.2 m/sec; if the louver has a gradient of 30° (recommended in cooling mode), the so-called "coanda" effect will occur, illustrated in the first figure, while at a gradient of 45°

(recommended in heating mode), there will be a downwards throw, as illustrated in the second figure.

**Note:** on heating it must be paid attention to rooms where the floor temperature is particularly low (for example less than 5 °C). In this situation the floor can cool the lower layer of air to a level that stops the uniform diffusion of the hot air coming from the unit, decreasing the throw figures shown in the table.

**With adjustable air diffusion louvers at 30°**

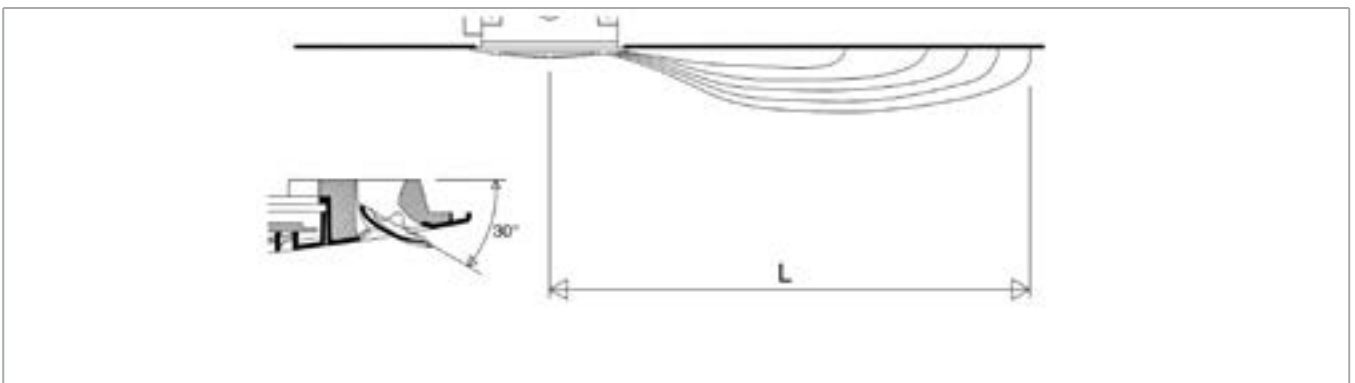

Model	ARMONIA020	040	120	140	TL 220	240	260	ARMONIA 320	340	360	ARMONIA 420	440	ARMONIA 520	540	560	ARMONIA 620	640	660	
Speed	Min	Med	Max	Min	Med	Max	Min	Med	Max	Min	Med	Max	Min	Med	Max	Min	Med	Max	
L	m	3,0	3,5	3,8	3,0	3,8	4,5	3,5	4,2	5,0	3,2	3,7	4,3	3,4	4,0	5,0	3,4	4,6	5,5

**With adjustable air diffusion louver at 45°**

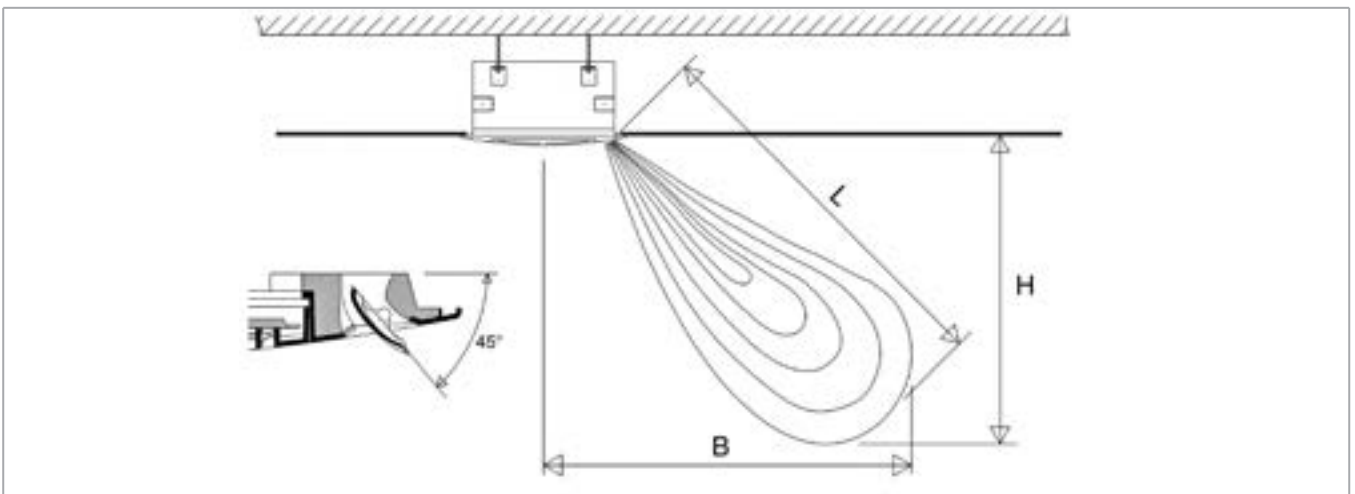

Model	ARMONIA020	040	120	140	TL 220	240	260	ARMONIA 320	340	360	ARMONIA 420	440	ARMONIA 520	540	560	ARMONIA 620	640	660	
Speed	Min	Med	Max	Min	Med	Max	Min	Med	Max	Min	Med	Max	Min	Med	Max	Min	Med	Max	
L	m	3,3	3,9	4,2	3,3	4,2	4,8	3,9	4,5	5,2	3,5	4,1	4,8	3,8	4,6	5,4	3,8	5,1	5,8
H	m	2,2	2,6	2,8	2,2	2,8	3,2	2,6	3,0	3,4	2,2	2,6	3,0	2,4	2,8	3,4	2,4	3,1	3,6
B	m	2,5	2,9	3,1	2,5	3,1	3,6	2,9	3,4	3,9	2,7	3,2	3,8	3,0	3,6	4,2	3,0	4,0	4,6

## ARMONIA CONTROLS

All the **ARMONIA** units can be supplied with a wide range of electronic wall controls that allows managing one single unit or several units (by using Dip-Switches or the power units).

The options range from the basic **WM-3V**, only for 3-speed control, to the highly sophisticated **TOTI** and **T2T2** electronic room thermostats, that regulate the room temperature precisely and are suitable when the user wants to set the fan speed.

The most evolved **AWUP**, **DC65** and **WM-503-AC-EC** versions allow both the manual and the automatic speed switch.

**Note:** all the controls are described in detail in the "Fan Coil Control Range literature".

### DC65 control (\*)



230 V 50-60 Hz

### TOTI control



230 V 50 Hz

### AWUP control (\*\*)



230 V 50-60 Hz

(\*) DC65 to be used with MB Card

(\*\*) DC65 to be used with TOAI

## Control systems

See from p. 49 for:

- the MB electronic board (to be fitted on the MB version)
- the MB controls and units

## ARMONIA-E VERSION

The 2 pipe model Cassette units are available with electric heater.

The electric heater is controlled in place of the hot water valve and not as integration to it.

The electric heaters are hermetically sealed and supplied inside the coil pipes and therefore can be only factory mounted.

The electric resistances of the units are for single phase 230V supply.

The Cassette fan coil unit includes no. 2 safety thermostats which intervene in case of internal over-heating, opening an auxiliary power relay (included in the electrical panel) which stops the power supply to the electric heaters.

Note: the cooling emission of the units is 95% of the emission in the tables of page p. 6.

### Constructional features of the electric heater

Model		ARMONIA 120	ARMONIA 220	ARMONIA 320	ARMONIA 420	ARMONIA 520	ARMONIA 620
Nominal installed power	W	1500	2500		3000		
Single-phase rated operating voltage	Vac/Ph/Hz	230/1/50					
Connecting wires	n x mm <sup>2</sup>	3 x 1,5	3 x 2,5				
Maximum current absorbed	A	7,0	11,0		13,5		
Recommended fuse <sup>(1)</sup>	A	8	12		16		
Max. ambient temperature <sup>(2)</sup>	°C	25					

<sup>(1)</sup> for the overload protection; gG type

<sup>(2)</sup> with electric heater in heating mode

## ARMONIA-E CONTROLS

### AWUP control (\*)



230 V 50-60 Hz

### DC65 control (\*\*)



230 V 50-60 Hz

(\*) To be used with TOAI

(\*\*) To be used with MB Card

### RCFF control

ID	Code
RCFF	LXTFF01M



With AC 3 speed motor

- 2 pipes On/OFF
- 2 pipes 3pts valve
- 2 pipes ON/OFF + EH
- 4 pipes ON/OFF
- 4 pipes 3pts valve

**Air diffuser**

**Version**

White ABS, RAL 9003.



**Version**

In ABS painted in one color to choose.



**Version**

Louvers and intake grid painted choice of one colour, frame in white ABS, RAL 9003.



**Version**

Louvers painted in one color to choose, intake grid and frame in white ABS, RAL 9003.



NOTE: The minimum quantity for panels with different colours is 20 pz.

## CONSTRUCTION FEATURES

**600 x 600 version**



**800 x 800 version**



### Air diffuser

Intake grids, frame and adjustable air distribution louvers on each side, made from ABS.

- Several Versions are available as options:
- PLASTIC DIFFUSER - WHITE - NOT FITTED
- PLASTIC DIFFUSER WITHOUT MOTORIZED FLAPS - WHITE - NOT FITTED
- PLASTIC DIFFUSER WITH MOTORIZED FLAPS - WHITE - NOT FITTED
- METALLIC DIFFUSER - WHITE - NOT FITTED
- PLASTIC DIFFUSER IN DIFFERENT RAL COLOURS (Min. qty 20 pcs)
- PLASTIC DIFFUSER IN DIFFERENT RAL COLOURS WITHOUT MOTORIZED FLAPS (Min. qty 20 pcs)
- PLASTIC DIFFUSER IN DIFFERENT RAL COLOURS WITH MOTORIZED FLAPS (Min. qty 20 pcs)

### Inner casing

It is made of galvanized steel with internal thermal insulation with polyolefin (PO) foam (B-s2-d0 EN 13501-01) and external anti-condensate lining.

### Control devices

- **ARMONIA-ECM** version

It consists of the pump control circuit board and the inverter circuit board.

- **ARMONIA-ECM-MB** version

It consists of the MB electronic board (that integrates pump control) and the inverter board.

### Fan assembly

The fan assembly, which is mounted on anti-vibrating supports, is extremely silent.

The radial fan has been designed to optimise performance, using wing profile blades with a shape that reduces turbulence, increasing efficiency and reducing noise.

The fans are connected to a three phase permanent magnet brushless electronic motor that is controlled with reconstructed current according to a BLAC sinusoidal wave.

The inverter board that controls the motor operation is powered by 230 Volt, single-phase and, with a switching

system, it generates a three-phase frequency modulated, wave form power supply.

The power supply of the unit is single phase 230-240 Vac 50/60 Hz.

### Coil

Made of copper tubes with bonded aluminium fins for maximum transfer contact.

2 or 3 row coil for 2 pipe models and 2+1 row coil for 4 pipe models (the heating row is on the inside part of the coil).

For 4 pipe systems two versions are available: the ARMONIA 140 and ARMONIA 440 serie supply an higher heating emission; and the ARMONIA 260 ARMONIA 360 ARMONIA 560 serie supply an higher cooling emission.

The coil is not suitable for use in corrosive atmosphere or in environments where aluminium may be subject to corrosion.

### Condensate collection tray

High density ABS polystyrene foam condensate tray, shaped in order to optimize the air diffusion.

Fire retardant rating B1 to DIN 4102.

### Filter

Synthetic washable filter, easily removable.

### Condensate drain pump

Float switch centrifugal pump with 650 mm of maximum head, integral to the unit and wired to the control panel on the outside of the casing.

The version with available pressure 1000 mm can be supplied on demand.

### Valve set

Two or three way valves for ON/OFF operation, with pipe mounting kit and lockshields.

## TECHNICAL FEATURES

### 2 pipe system

The following standard rating conditions are used:

#### COOLING

Entering air temperature: + 27 °C d.b. + 19 °C w.b.

Water temperature: +7 °C E.W.T. +12 °C L.W.T.

#### HEATING

Entering air temperature: + 20 °C

Water temperature: +45 °C E.W.T. +40 °C L.W.T.

MODEL		ARMONIA-ECM 120					ARMONIA-ECM 220					ARMONIA-ECM 320				
		1	3	5	7,5	10	1	3	5	7,5	10	1	3	5	7,5	10
Inverter speed signal (Vdc)																
Air flow	m <sup>3</sup> /h	310	345	380	457	535	310	377	445	577	710	360	485	610	745	880
Cooling total emission	kW	1,84	2,01	2,16	2,47	2,73	2,24	2,65	3,04	3,71	4,30	2,55	3,25	3,85	4,45	4,96
Cooling sensible emission	kW	1,35	1,47	1,60	1,84	2,07	1,57	1,87	2,16	2,67	3,15	1,80	2,31	2,79	3,25	3,68
Heating emission	kW	1,85	2,04	2,22	2,55	2,87	2,12	2,56	2,98	3,68	4,36	2,46	3,17	3,85	4,52	5,15
Dp Cooling	kPa	4,9	5,8	6,6	8,4	10,1	4,6	6,3	9,4	11,6	15,1	5,9	9,1	12,4	16,2	19,7
Dp Heating	kPa	4,3	5,1	5,9	7,6	9,4	3,6	5,1	6,6	9,7	13,2	4,7	7,5	10,6	14,1	17,8
Sound power (Lw)	dB(A)	33,0	36,0	39,0	43,0	47,0	33,0	38,0	43,0	48,5	54,0	37,0	43,5	50,0	55,0	60,0
Sound pressure (Lp) <sup>(1)</sup>	dB(A)	24,0	27,0	30,0	34,0	38,0	24,0	29,0	34,0	39,5	45,0	28,0	34,5	41,0	46,0	51,0
Fan	W	5,0	6,5	8,0	12,0	16,0	5,0	8,0	11,0	21,0	31,0	7,0	14,0	21,0	41,5	62,0
Condensate drain pump power absorption	W	10	10	10	10	10	10	10	10	10	10	10	10	10	10	10
Water content	l	1,4	1,4	1,4	1,4	1,4	2,1	2,1	2,1	2,1	2,1	2,1	2,1	2,1	2,1	2,1
Length	mm	575	575	575	575	575	575	575	575	575	575	575	575	575	575	575
Depth	mm	575	575	575	575	575	575	575	575	575	575	575	575	575	575	575
Height	mm	275	275	275	275	275	275	275	275	275	275	275	275	275	275	275

MODEL		ARMONIA-ECM 420					ARMONIA-ECM 520				
		1	3	5	7,5	10	1	3	5	7,5	10
Inverter speed signal (Vdc)											
Air flow	m <sup>3</sup> /h	630	750	870	1017	1165	710	920	1130	1450	1770
Cooling total emission	kW	4,20	4,70	5,13	5,76	6,30	5,28	6,54	7,69	9,28	10,69
Cooling sensible emission	kW	3,02	3,39	3,75	4,23	4,69	3,68	4,62	5,50	6,71	7,83
Heating emission	kW	4,27	4,78	5,30	6,02	6,70	4,90	6,18	7,34	9,00	10,56
Dp Cooling	kPa	10,9	13,3	15,6	19,3	22,7	9,4	13,8	18,5	26,1	33,0
Dp Heating	kPa	9,6	11,8	14,2	17,9	21,6	7,0	10,7	14,6	21,1	28,1
Sound power (Lw)	dB(A)	33,0	36,0	39,0	43,5	48,0	34,0	40,5	47,0	52,0	57,0
Sound pressure (Lp) <sup>(1)</sup>	dB(A)	24,0	27,0	30,0	34,5	39,0	25,0	31,5	38,0	43,0	48,0
Fan	W	10,0	13,5	17,0	25,0	33,0	10,0	21,0	32,0	70,0	108,0
Condensate drain pump power absorption	W	10	10	10	10	10	10	10	10	10	10
Water content	l	3,0	3,0	3,0	3,0	3,0	4,0	4,0	4,0	4,0	4,0
Length	mm	820	820	820	820	820	820	820	820	820	820
Depth	mm	820	820	820	820	820	820	820	820	820	820
Height	mm	303	303	303	303	303	303	303	303	303	303

<sup>(1)</sup> The sound pressure levels are 9 dB (A) lower than the sound power levels, apply to the reverberant field of a 100 m<sup>3</sup> room and a reverberation time of 0.5 sec.

## 4 pipe system

The following standard rating conditions are used:

### COOLING

Entering air temperature: + 27 °C d.b. + 19 °C w.b.

Water temperature: +7 °C E.W.T. +12 °C L.W.T.

### HEATING

Entering air temperature: + 20 °C

Water temperature: +65 °C E.W.T. +55 °C L.W.T.

MODEL	Inverter speed signal (Vdc)	ARMONIA-ECM 140					ARMONIA-ECM 260					ARMONIA-ECM 360				
		1	3	5	7,5	10	1	3	5	7,5	10	1	3	5	7,5	10
Air flow	m <sup>3</sup> /h	310	345	380	457	535	310	377	445	577	710	360	485	610	745	880
Cooling total emission	kW	1,85	2,02	2,17	2,48	2,75	2,09	2,46	2,81	3,39	3,90	2,37	2,99	3,51	4,03	4,47
Cooling sensible emission	kW	1,34	1,31	1,59	1,64	2,06	1,49	1,76	2,03	2,49	2,92	1,70	2,17	2,60	3,01	3,40
Heating emission	kW	2,13	2,32	2,51	2,85	3,18	1,73	1,97	2,20	2,57	2,91	1,92	2,31	2,66	2,99	3,29
Dp Cooling	kPa	4,6	5,4	6,2	7,9	9,5	3,3	4,4	5,6	7,9	10,3	4,1	6,3	8,4	10,9	13,1
Dp Heating	kPa	4,6	5,3	6,1	7,7	9,4	2,6	3,3	4,1	5,4	6,7	3,2	4,4	5,7	7,1	8,4
Sound power (Lw)	dB(A)	33,0	36,0	39,0	43,0	47,0	33,0	38,0	43,0	48,5	54,0	37,0	43,5	50,0	55,0	60,0
Sound pressure (Lp) <sup>(1)</sup>	dB(A)	24,0	27,0	30,0	34,0	38,0	24,0	29,0	34,0	39,5	45,0	28,0	34,5	41,0	46,0	51,0
Fan	W	5,0	6,5	8,0	12,0	16,0	5,0	8,0	11,0	21,0	31,0	7,0	14,0	21,0	41,5	62,0
Condensate drain pump power absorption	W	10	10	10	10	10	10	10	10	10	10	10	10	10	10	10
Cooling water content	l	1,4	1,4	1,4	1,4	1,4	1,7	1,7	1,7	1,7	1,7	1,7	1,7	1,7	1,7	1,7
Heating water content	l	0,7	0,7	0,7	0,7	0,7	0,5	0,5	0,5	0,5	0,5	0,5	0,5	0,5	0,5	0,5
Length	mm	575	575	575	575	575	575	575	575	575	575	575	575	575	575	575
Depth	mm	575	575	575	575	575	575	575	575	575	575	575	575	575	575	575
Height	mm	275	275	275	275	275	275	275	275	275	275	275	275	275	275	275

MODEL	Inverter speed signal (Vdc)	ARMONIA-ECM 440					ARMONIA-ECM 560				
		1	3	5	7,5	10	1	3	5	7,5	10
Air flow	m <sup>3</sup> /h	630	750	870	1017	1165	710	920	1130	1450	1770
Cooling total emission	kW	4,29	4,81	5,29	5,92	6,48	4,97	6,13	7,14	8,56	9,76
Cooling sensible emission	kW	3,07	3,46	3,82	4,32	4,80	3,51	4,37	5,17	6,27	7,29
Heating emission	kW	5,41	6,04	6,65	7,46	8,24	4,58	5,47	6,27	7,36	8,33
Dp Cooling	kPa	9,4	11,6	13,6	16,8	19,8	8,8	12,9	17,0	23,7	30,1
Dp Heating	kPa	8,5	10,3	12,3	15,1	18,1	4,9	6,7	8,6	11,4	14,3
Sound power (Lw)	dB(A)	33,0	36,0	39,0	43,5	48,0	34,0	40,5	47,0	52,0	57,0
Sound pressure (Lp) <sup>(1)</sup>	dB(A)	24,0	27,0	30,0	34,5	39,0	25,0	31,5	38,0	43,0	48,0
Fan	W	10,0	13,5	17,0	25,0	33,0	10,0	21,0	32,0	70,0	108,0
Condensate drain pump power absorption	W	10	10	10	10	10	10	10	10	10	10
Cooling water content	l	3,0	3,0	3,0	3,0	3,0	3,6	3,6	3,6	3,6	3,6
Heating water content	l	1,4	1,4	1,4	1,4	1,4	1,1	1,1	1,1	1,1	1,1
Length	mm	820	820	820	820	820	820	820	820	820	820
Depth	mm	820	820	820	820	820	820	820	820	820	820
Height	mm	303	303	303	303	303	303	303	303	303	303

<sup>(1)</sup> The sound pressure levels are 9 dB (A) lower than the sound power levels, apply to the reverberant field of a 100 m<sup>3</sup> room and a reverberation time of 0.5 sec.

**COOLING EMISSION**

**Models with single coil (2 pipe installations)**

**Entering air temperature: 27 °C – R.H.: 50%**

Model	Vdc	WT: 7 / 12 °C				WT: 8 / 13 °C			WT: 10 / 15 °C			WT: 12 / 17 °C		
		Qv m <sup>3</sup> /h	Pc kW	Ps kW	Qw l/h	Pc kW	Ps kW	Qw l/h	Pc kW	Ps kW	Qw l/h	Pc kW	Ps kW	Qw l/h
ARMONIA-ECM 120	10	535	2,94	2,06	506	2,64	1,94	455	1,78	1,78	307	1,53	1,53	263
	7,5	457	2,64	1,84	455	2,38	1,73	409	1,88	1,52	323	1,36	1,36	234
	5	380	2,32	1,60	399	2,09	1,50	360	1,65	1,32	284	1,20	1,20	206
	3	345	2,15	1,47	370	1,94	1,38	334	1,54	1,22	264	1,10	1,10	190
	1	310	1,97	1,34	339	1,78	1,26	307	1,41	1,11	242	1,00	1,00	173
ARMONIA-ECM 220	10	710	4,61	3,14	792	4,16	2,95	716	3,29	2,60	566	2,35	2,35	404
	7,5	577	3,96	2,67	681	3,59	2,51	617	2,85	2,20	490	2,20	1,93	379
	5	445	3,25	2,16	559	2,95	2,03	508	2,35	1,78	403	1,81	1,56	312
	3	377	2,83	1,87	487	2,57	1,76	442	2,06	1,54	354	1,59	1,35	274
	1	310	2,39	1,56	410	2,17	1,47	373	1,75	1,29	300	1,35	1,13	232
ARMONIA-ECM 320	10	880	5,32	3,67	916	4,80	3,45	825	3,80	3,04	653	2,74	2,74	471
	7,5	745	4,75	3,24	817	4,29	3,05	738	3,40	2,69	585	2,43	2,43	417
	5	610	4,13	2,79	710	3,74	2,62	643	2,97	2,31	510	2,29	2,02	394
	3	485	3,46	2,31	596	3,14	2,17	541	2,49	1,91	429	1,93	1,67	332
	1	360	2,73	1,80	470	2,48	1,69	426	1,99	1,49	342	1,54	1,30	264
ARMONIA-ECM 420	10	1165	6,76	4,67	1162	6,10	4,40	1049	4,80	3,88	826	3,48	3,48	599
	7,5	1017	6,15	4,22	1057	5,55	3,97	955	4,39	3,49	755	3,14	3,14	541
	5	870	5,50	3,74	945	4,97	3,52	856	3,93	3,10	675	2,79	2,79	480
	3	750	5,01	3,39	861	4,54	3,19	780	3,60	2,80	619	2,55	2,55	438
	1	630	4,49	3,02	772	4,07	2,84	426	3,23	2,49	556	2,50	2,18	430
ARMONIA-ECM 520	10	1770	11,41	7,81	1962	10,30	7,35	1772	8,20	6,48	1410	5,89	5,89	1012
	7,5	1450	9,90	6,70	1702	8,96	6,29	1541	7,14	5,55	1227	5,53	4,87	951
	5	1130	8,22	5,49	1415	7,45	5,17	1281	5,96	4,54	1026	4,60	3,98	791
	3	920	6,98	4,61	1200	6,34	4,34	1090	5,09	3,81	875	3,92	3,33	675
	1	710	5,63	3,68	968	5,12	3,46	881	4,13	3,04	710	3,20	2,66	550

WT: Water temperature  
Vdc: Inverter speed signal (Vdc)  
Qv: Air flow  
Pc: Cooling total emission  
Ps: Cooling sensible emission  
Qw: Water flow rate

## Models with double coil (4 pipe installations)

Entering air temperature: 27 °C – R.H.: 50%

Model	Vdc	WT: 7 / 12 °C			WT: 8 / 13 °C			WT: 10 / 15 °C			WT: 12 / 17 °C			
		Qv m <sup>3</sup> /h	Pc kW	Ps kW	Qw l/h	Pc kW	Ps kW	Qw l/h	Pc kW	Ps kW	Qw l/h	Pc kW	Ps kW	Qw l/h
ARMONIA-ECM 140	10	535	2,95	2,05	508	2,66	1,93	458	1,77	1,77	305	1,52	1,52	261
	7,5	457	2,65	1,83	456	2,39	1,72	412	1,89	1,52	325	1,37	1,37	235
	5	380	2,33	1,59	401	2,10	1,50	362	1,66	1,32	286	1,19	1,19	204
	3	345	2,16	1,47	371	1,95	1,38	336	1,54	1,21	265	1,09	1,09	188
	1	310	1,98	1,33	340	1,79	1,26	308	1,41	1,10	242	0,99	0,99	171
ARMONIA-ECM 260	10	710	4,19	2,91	720	3,77	2,73	648	2,98	2,41	513	2,16	2,16	372
	7,5	577	3,62	2,49	623	3,27	2,34	562	2,59	2,06	446	1,85	1,85	319
	5	445	3,00	2,03	516	2,71	1,91	467	2,15	1,68	369	1,52	1,52	261
	3	377	2,63	1,76	452	2,38	1,66	409	1,90	1,46	326	1,46	1,28	251
	1	310	2,23	1,48	383	2,02	1,39	347	1,61	1,22	277	1,24	1,07	214
ARMONIA-ECM 360	10	880	4,80	3,38	826	4,31	3,18	742	3,41	2,81	586	2,51	2,51	431
	7,5	745	4,31	3,00	742	3,88	2,82	667	3,06	2,49	527	2,23	2,23	384
	5	610	3,77	2,60	649	3,40	2,44	585	2,69	2,15	462	1,94	1,94	333
	3	485	3,19	2,17	548	2,88	2,04	496	2,28	1,79	393	1,62	1,62	278
	1	360	2,54	1,70	436	2,30	1,60	395	1,83	1,40	314	1,41	1,23	243
ARMONIA-ECM 440	10	1165	6,95	4,79	1196	6,28	4,50	1080	4,95	3,96	851	3,56	3,56	613
	7,5	1017	6,31	4,31	1086	5,71	4,06	982	4,51	3,57	775	3,21	3,21	553
	5	870	5,64	3,82	969	5,10	3,59	878	4,05	3,16	697	2,88	2,88	495
	3	750	5,13	3,45	882	4,65	3,25	800	3,69	2,86	634	2,60	2,60	447
	1	630	4,59	3,07	790	4,17	2,89	717	3,30	2,54	567	2,55	2,22	439
ARMONIA-ECM 560	10	1770	10,47	7,26	1801	9,44	6,83	1623	7,48	6,03	1286	5,42	5,42	933
	7,5	1450	9,14	6,25	1571	8,25	5,88	1419	6,53	5,18	1123	4,68	4,68	805
	5	1130	7,65	5,17	1315	6,93	4,86	1191	5,48	4,27	942	4,25	3,74	731
	3	920	6,53	4,36	1123	5,93	4,10	1019	4,71	3,60	810	3,63	3,16	625
	1	710	5,31	3,51	913	4,83	3,30	831	3,86	2,90	664	2,99	2,53	514

WT: Water temperature  
Vdc: Inverter speed signal (Vdc)  
Qv: Air flow  
Pc: Cooling total emission  
Ps: Cooling sensible emission  
Qw: Water flow rate

## HEATING EMISSION

### Models with single coil (2 pipe installations)

Entering air temperature: +20 °C

Model	Vdc	Qv m <sup>3</sup> /h	WT: 70 / 60 °C		WT: 60 / 50 °C		WT: 55 / 45 °C		WT: 50 / 40 °C		WT: 45 / 40 °C	
			Ph kW	Qw l/h	Ph kW	Qw l/h	Ph kW	Qw l/h	Ph kW	Qw l/h	Ph kW	Qw l/h
ARMONIA-ECM 120	10	535	5,82	500	4,49	387	3,83	330	3,17	272	2,87	247
	7,5	457	5,16	444	3,99	343	3,41	293	2,82	243	2,55	219
	5	380	4,51	387	3,49	300	2,99	257	2,48	213	2,22	191
	3	345	4,13	355	3,21	276	2,74	236	2,28	196	2,04	176
	1	310	3,75	322	2,91	250	2,49	214	2,07	178	1,85	159
ARMONIA-ECM 220	10	710	8,81	758	6,85	589	5,87	505	4,89	420	4,36	375
	7,5	577	7,44	640	5,80	499	4,97	428	4,15	357	3,68	317
	5	445	6,01	517	4,70	404	4,04	347	3,38	290	2,98	256
	3	377	5,16	444	4,05	348	3,48	300	2,92	251	2,56	220
	1	310	4,28	368	3,36	289	2,90	249	2,43	209	2,12	183
ARMONIA-ECM 320	10	880	10,42	896	8,09	696	6,92	595	5,75	494	5,15	443
	7,5	745	9,14	786	7,11	611	6,09	524	5,06	435	4,52	389
	5	610	7,79	670	6,07	522	5,20	448	4,34	373	3,85	331
	3	485	6,41	551	5,01	430	4,30	370	3,59	309	3,17	273
	1	360	4,96	427	3,89	335	3,35	288	2,81	241	2,46	212
ARMONIA-ECM 420	10	1165	13,54	1165	10,51	904	9,00	774	7,47	642	6,70	576
	7,5	1017	12,16	1046	9,46	813	8,10	696	6,73	579	6,02	517
	5	870	10,72	922	8,34	717	7,15	615	5,95	512	5,30	456
	3	750	9,65	830	7,52	647	6,45	555	5,38	463	4,78	411
	1	630	8,61	741	6,72	578	5,78	497	4,82	415	4,27	367
ARMONIA-ECM 520	10	1770	21,37	1837	16,60	1428	14,21	1222	11,81	1015	10,56	908
	7,5	1450	18,20	1565	14,17	1219	12,15	1045	10,11	870	9,00	774
	5	1130	14,82	1274	11,56	994	9,93	854	8,29	713	7,34	631
	3	920	12,47	1073	9,76	839	8,40	722	7,02	604	6,18	532
	1	710	9,87	849	7,74	666	6,67	574	5,60	481	4,90	421

WT: Water temperature  
 Vdc: Inverter speed signal (Vdc)  
 Qv: Air flow  
 Ph: Heating emission  
 Qw: Water flow rate

## Models with double coil (4 pipe installations)

Entering air temperature: +20 °C

Model	Vdc	Qv m <sup>3</sup> /h	WT: 70 / 60 °C		WT: 60 / 50 °C		WT: 55 / 45 °C		WT: 50 / 40 °C		WT: 45 / 40 °C	
			Ph kW	Qw l/h	Ph kW	Qw l/h	Ph kW	Qw l/h	Ph kW	Qw l/h	Ph kW	Qw l/h
ARMONIA-ECM 140	10	535	3,62	311	2,74	236	2,30	198	1,87	161	1,78	305
	7,5	457	3,24	279	2,46	212	2,07	178	1,68	144	1,59	274
	5	380	2,85	245	2,16	186	1,82	156	1,48	127	1,40	241
	3	345	2,64	227	2,01	172	1,69	145	1,37	118	1,30	223
	1	310	2,43	209	1,84	158	1,55	133	1,26	108	1,19	205
ARMONIA-ECM 260	10	710	3,35	288	2,48	213	2,04	176	1,61	139	1,62	279
	7,5	577	2,96	254	2,19	189	1,81	156	1,43	123	1,43	247
	5	445	2,53	217	1,87	161	1,55	133	1,23	106	1,23	211
	3	377	2,27	195	1,68	145	1,39	120	1,11	95	1,10	189
	1	310	1,98	170	1,47	127	1,22	105	0,97	83	0,96	165
ARMONIA-ECM 360	10	880	3,79	326	2,80	241	2,31	198	1,82	156	1,83	315
	7,5	745	3,44	296	2,54	219	2,10	181	1,66	142	1,67	286
	5	610	3,06	263	2,27	195	1,87	161	1,48	127	1,48	255
	3	485	2,66	229	1,97	170	1,63	140	1,29	111	1,29	222
	1	360	2,20	189	1,64	141	1,36	117	1,08	93	1,07	184
ARMONIA-ECM 440	10	1165	9,36	805	7,13	613	6,01	517	4,90	421	4,61	793
	7,5	1017	8,48	729	6,46	555	5,45	468	4,44	382	4,17	718
	5	870	7,54	649	5,75	494	4,85	417	3,96	340	3,72	639
	3	750	6,86	590	5,23	450	4,41	380	3,60	310	3,38	581
	1	630	6,14	528	4,68	403	3,96	340	3,23	278	3,03	521
ARMONIA-ECM 560	10	1770	9,51	818	7,15	615	5,97	514	4,80	413	4,65	800
	7,5	1450	8,40	722	6,32	543	5,28	454	4,25	365	4,11	706
	5	1130	7,16	616	5,39	464	4,51	388	3,63	312	3,50	603
	3	920	6,24	537	4,70	405	3,94	339	3,18	273	3,06	526
	1	710	5,22	449	3,94	339	3,30	284	2,67	229	2,56	440

WT: Water temperature  
Vdc: Inverter speed signal (Vdc)  
Qv: Air flow  
Ph: Heating emission  
Qw: Water flow rate

WATER SIDE PRESSURE DROP

2 pipe system

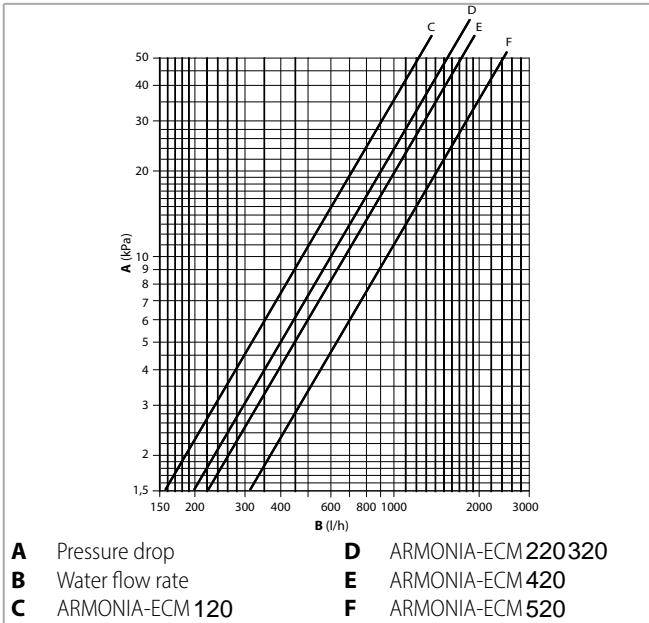

The water pressure drop figures refer to a mean water temperature of 10 °C; for different temperatures, multiply the pressure drop figures by the correction factors K.

K correction factor	Mean water temperature (°C)						
	20	30	40	50	60	70	80
	0,94	0,90	0,86	0,82	0,78	0,74	0,70

4 pipe system

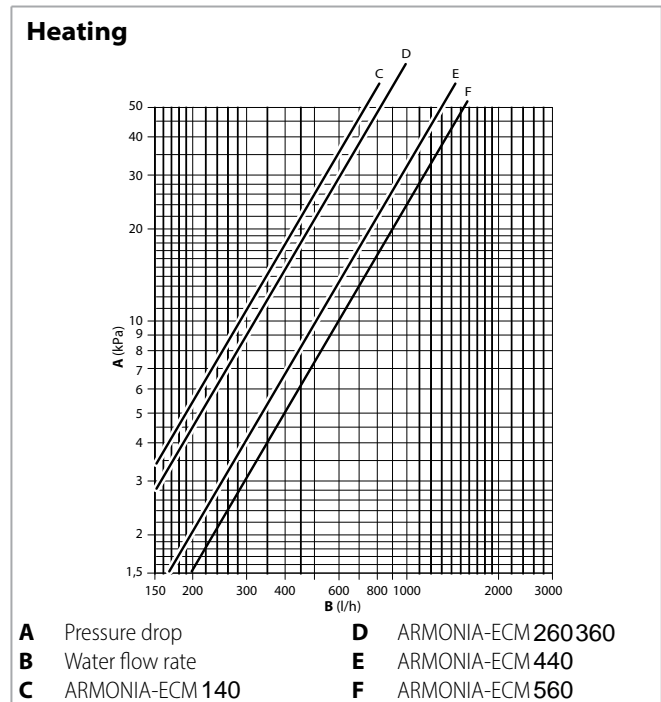
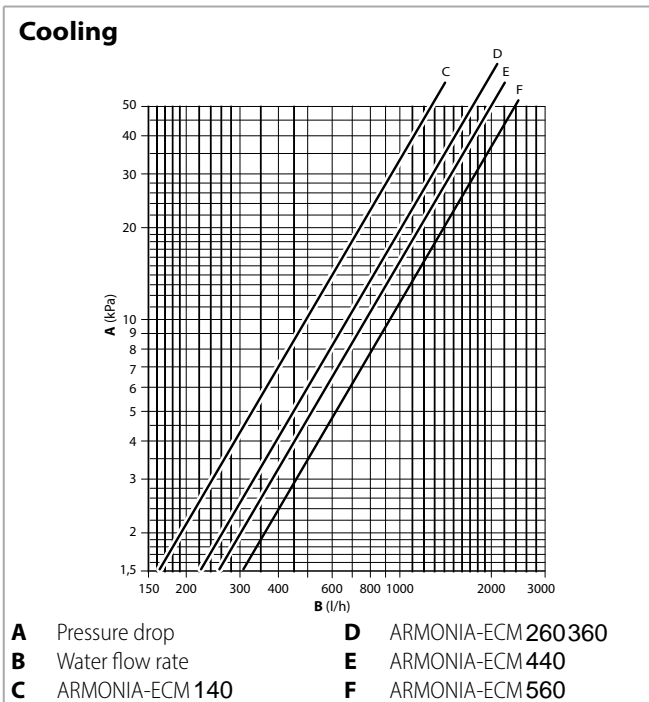

The water pressure drop figures refer to a mean water temperature of 10 °C; for different temperatures, multiply the pressure drop figures by the correction factors K.

K correction factor	Mean water temperature (°C)						
	20	30	40	50	60	70	80
	0,94	0,90	0,86	0,82	0,78	0,74	0,70

The water pressure drop figures refer to a mean water temperature of 60 °C; for different temperatures, multiply the pressure drop figures by the correction factors K.

K correction factor	Mean water temperature (°C)			
	40	50	70	80
	1,12	1,06	0,94	0,88

**OPERATION LIMITS**

Description		UoM	Value
Water flow	Max. water side pressure	bars	10
		kPa	1000
	Lowest water inlet temperature	°C	+6
	Highest water inlet temperature	°C	+80
Power supply	Single-phase rated operating voltage	V/Hz	230/50-60

For maximum installation height, see p. 32.



**DIMENSION AND WEIGHT**

**ARMONIA-ECM 120 140 / ARMONIA-ECM 220 260 / ARMONIA-ECM 320 360 (600 x 600 version)**

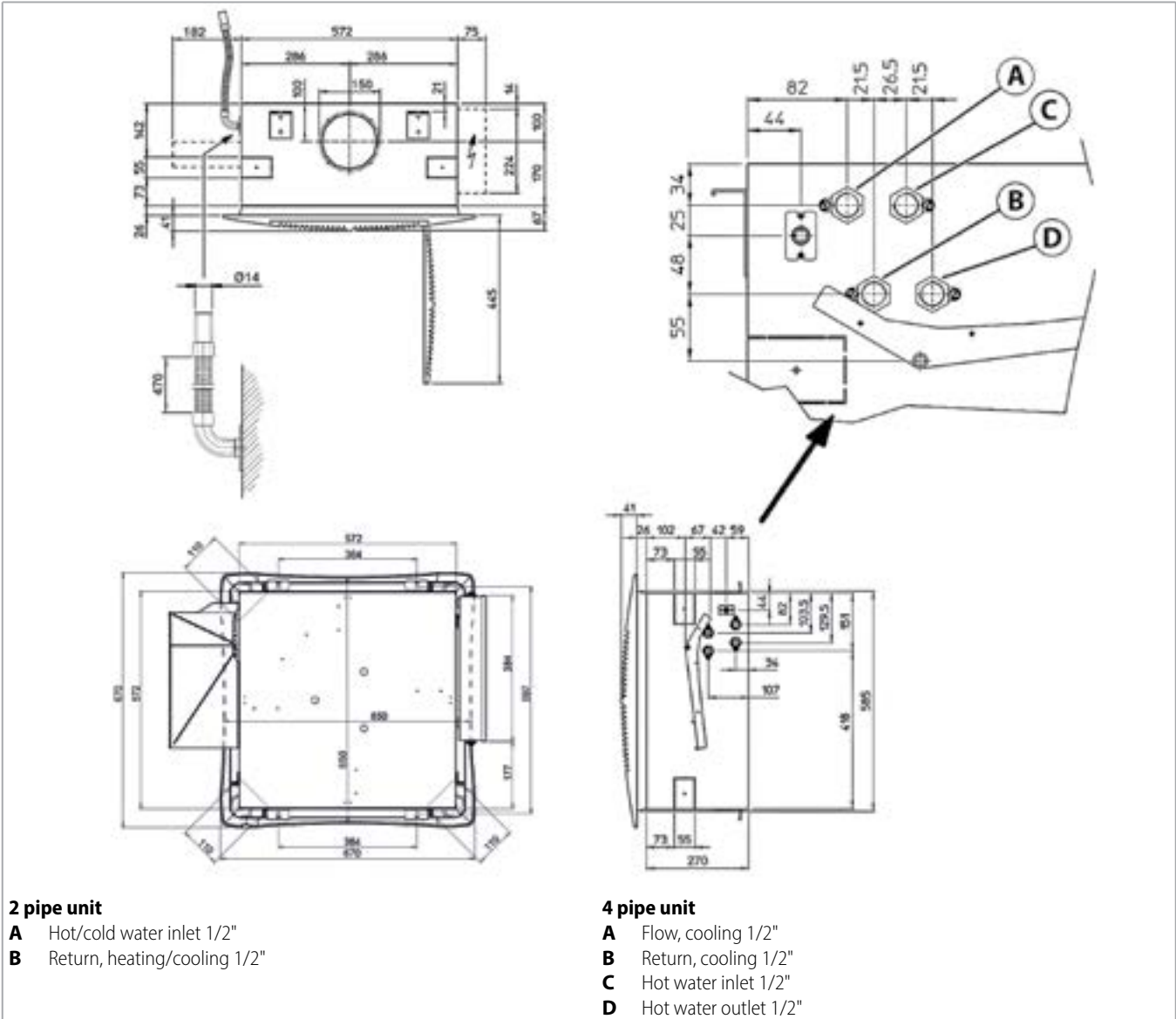

**Packed unit**

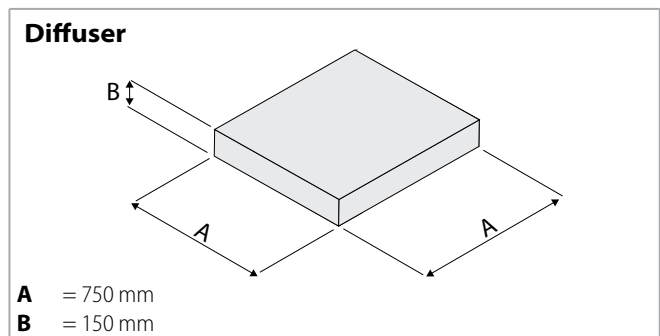
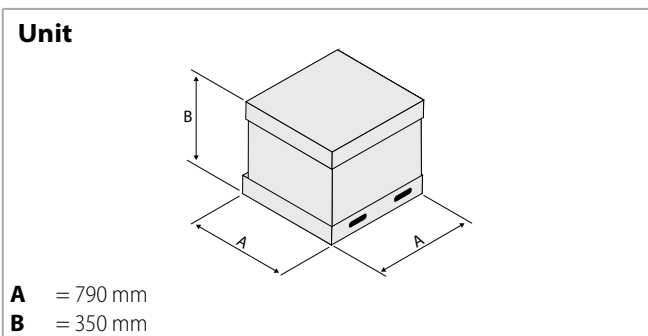

Weight/Model		120	140	220 260	320 360
With packaging	kg	20,0	22,0	21,5	21,0
Without packaging	kg	17,0	19,0	18,5	18,0

Weight/Model		120	140	220 260	320 360
With packaging	kg			3,5	
Without packaging	kg			2,5	

**ARMONIA-ECM 420 440 / ARMONIA-ECM 520 560 (800 x 800 version)**

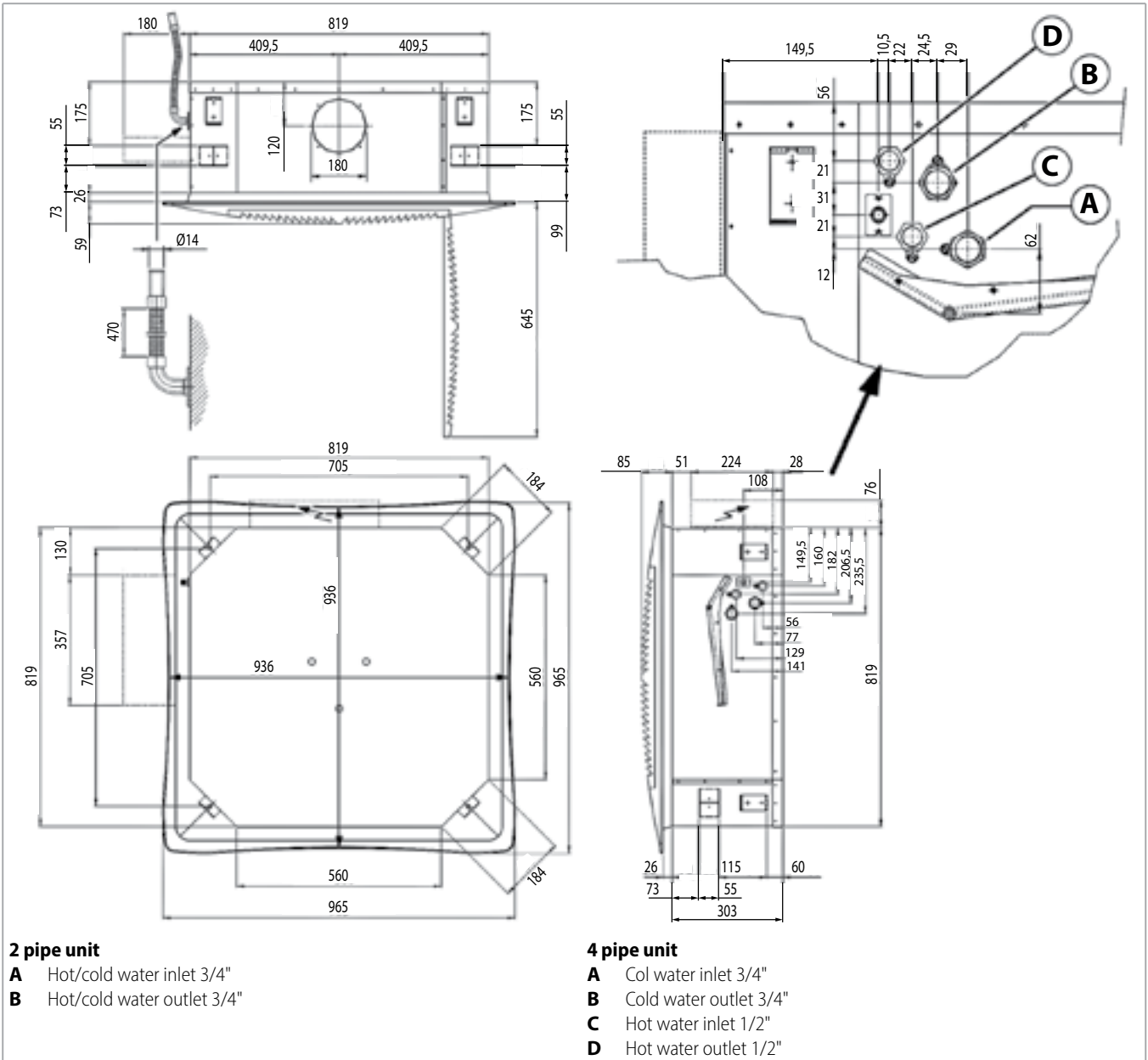

**Packed unit**

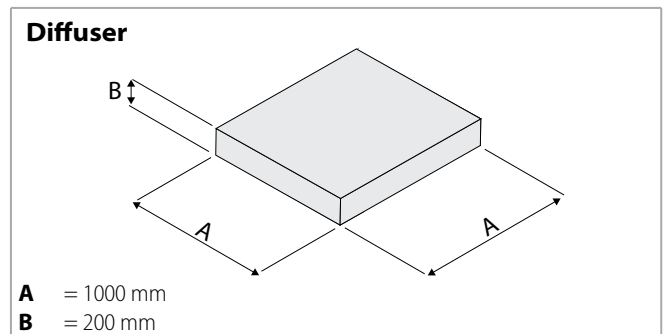
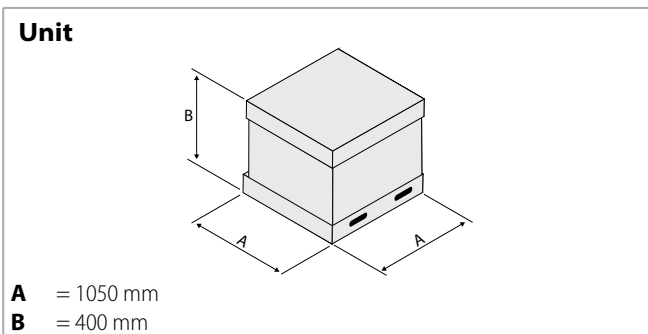

Weight/Model		420	440	520 560
With packaging	kg	35		40
Without packaging	kg	31		35

Weight/Model		420	440	520 560
With packaging	kg		7,0	
Without packaging	kg		5,5	

**Metal air inlet grid MD 600 / MD 800**

(RS receiver, Code 9066338, for metal diffuser for MB units)

Not suitable with electronic electrostatic filter.

Model	Code
MD-600	9079420
MD-800	9079417

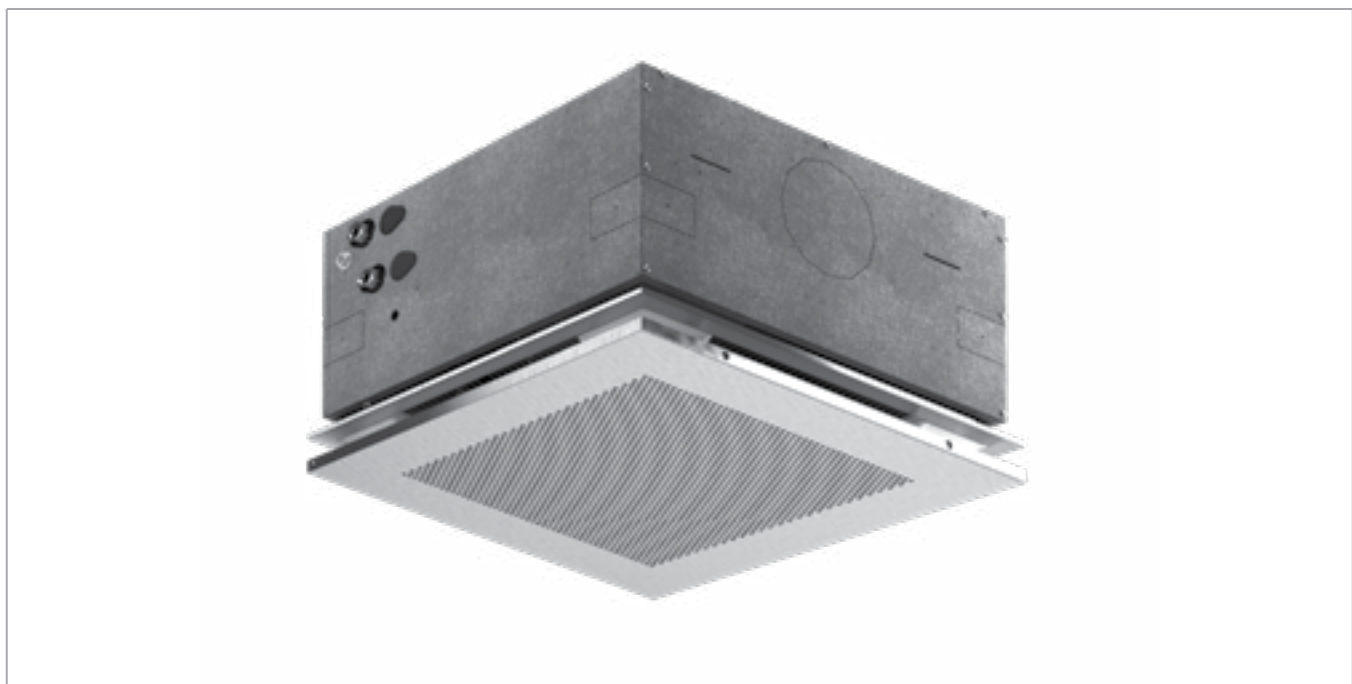
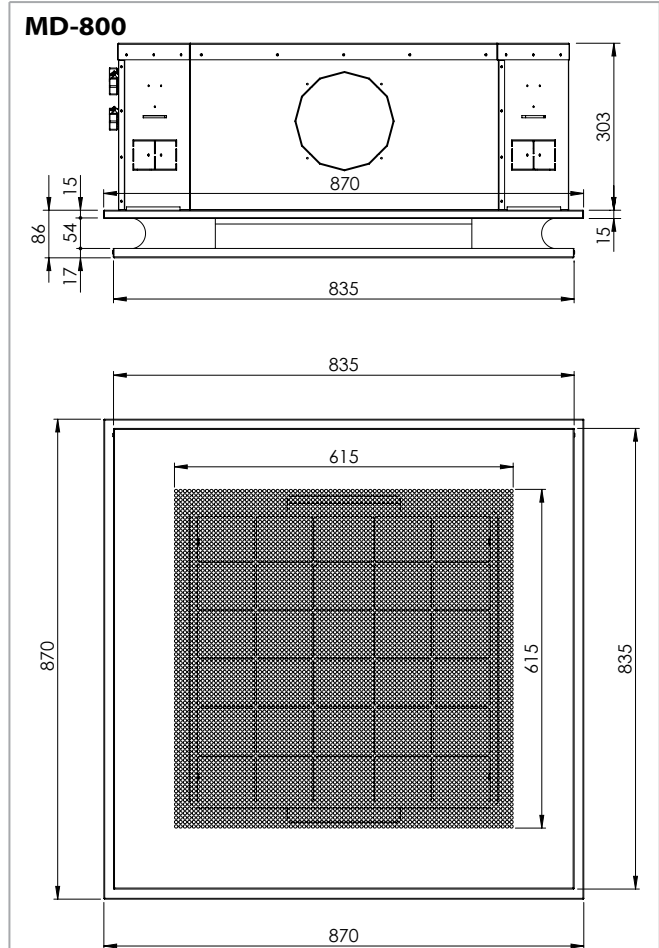
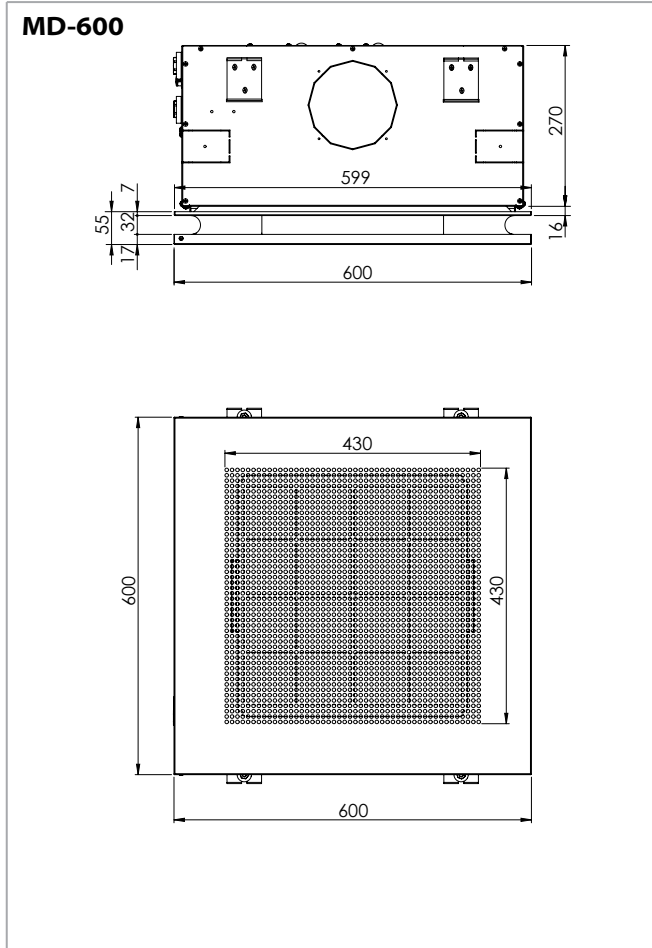

**AIR THROW**

The air throw indicated in the tables must only be considered the maximum value, as it may change significantly in relation to the dimensions of the room in which the appliance is installed and the positioning of the furniture in the room.

The useful throw L refers to the distance between the unit and the point where the air speed is 0.2 m/sec; if the louver has a gradient of 30° (recommended in cooling mode), the so-called "coanda" effect will occur, illustrated in the first figure, while at a gradient of 45°

(recommended in heating mode), there will be a downwards throw, as illustrated in the second figure.

**Note:** on heating it must be paid attention to rooms where the floor temperature is particularly low (for example less than 5 °C). In this situation the floor can cool the lower layer of air to a level that stops the uniform diffusion of the hot air coming from the unit, decreasing the throw figures shown in the table.

**With adjustable air diffusion louvers at 30°**

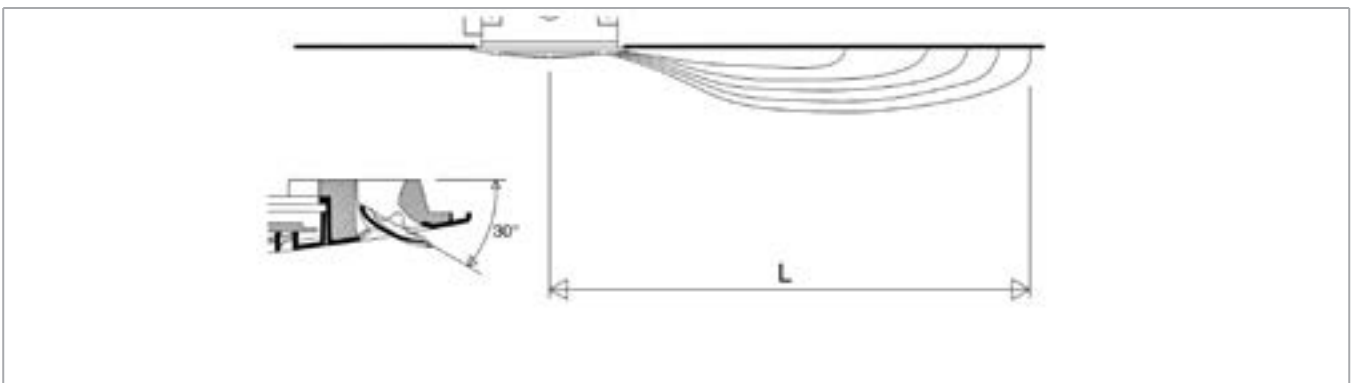

Model	ARMONIA-ECM 120 140			ARMONIA-ECM 220 260			ARMONIA-ECM 320 360			ARMONIA-ECM 420 440			ARMONIA-ECM 520 560			
Vdc	1	5	10	1	5	10	1	5	10	1	5	10	1	5	10	
L	m	3,0	3,5	3,8	3,0	3,8	4,5	3,5	4,2	5,0	3,2	3,7	4,3	3,4	4,0	5,0

Vdc = Inverter speed signal

**With adjustable air diffusion louver at 45°**

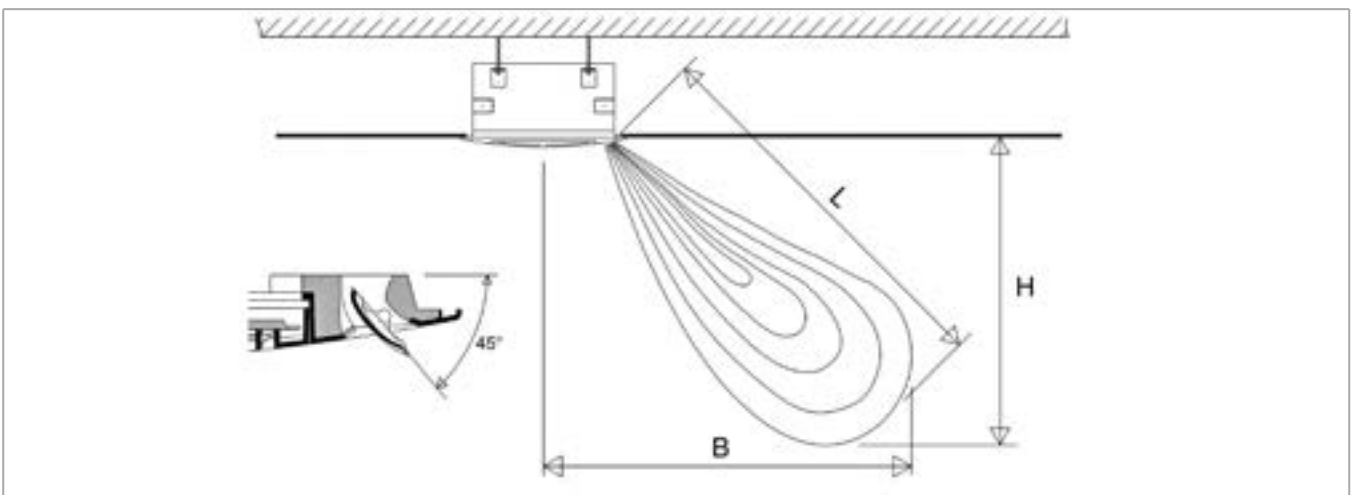

Model	ARMONIA-ECM 120 140			ARMONIA-ECM 220 260			ARMONIA-ECM 320 360			ARMONIA-ECM 420 440			ARMONIA-ECM 520 560			
Vdc	1	5	10	1	5	10	1	5	10	1	5	10	1	5	10	
L	m	3,3	3,9	4,2	3,3	4,2	4,8	3,9	4,5	5,2	3,5	4,1	4,8	3,8	4,6	5,4
H	m	2,2	2,6	2,8	2,2	2,8	3,2	2,6	3,0	3,4	2,2	2,6	3,0	2,4	2,8	3,4
B	m	2,5	2,9	3,1	2,5	3,1	3,6	2,9	3,4	3,9	2,7	3,2	3,8	3,0	3,6	4,2

Vdc = Inverter speed signal

**CONTROLS FOR ARMONIA-ECM UNITS**

**ARMONIA-ECM version**

For this Cassette configuration, the 1-10 Vdc speed signal, which controls the inverter, must be supplied by a controller with the following signal specifications:

**Fan coil control signal**

- Fan OFF = 0 Vdc
- Fan ON > 1 Vdc
- Max. speed = 10 Vdc

**ECM Blac inverter board**

- 0÷10 Vdc Circuit Input Impedance Value = 68 kOhm

**Power supply**

230Vac 1Ph 50-60Hz

**Controls**

All the units of the **ARMONIA-ECM** range can be supplied with a wide range of controls that allows managing one single unit or several units (with the use of the power units).

The room temperature can be controlled through wall electronic room thermostats, with different solutions according to every ambient conditions.

The **AWUP**, **DC65** and **RCFZ** electronic thermostats control the room temperature precisely and are suitable when the user wants to set the fan speed.

**Note:** all the controls are described in detail in the "Fan Coil Control Range literature".

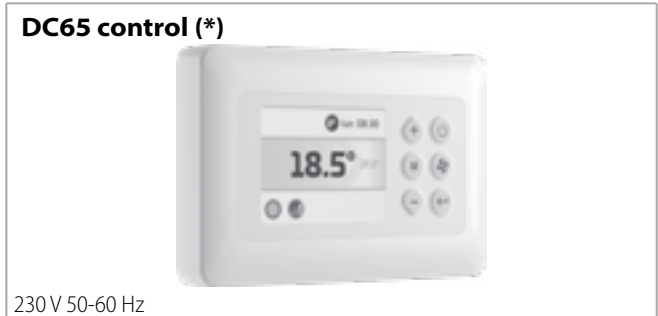

(\*) To be used with TOAI . DC65 to be used with MB Card

## Control systems

See from p. 49 for:

- the MB electronic board (to be fitted on the MB version)
- the MB controls and units

## TSMA control

ID	Code
TSMA	LXGFW01X



- Simple installation : Recessed installation on electric box ( standard 503). Parameter configuration is guided, depending on the type of system.
- Fan coil speed : Manual or automatic selection of the fan speed for 3-speed AC motor or an EC motor with 0-10 V control.
- Summer/Winter : Manual, centralized, or automatic selection of the summer/winter mode.
- MODBUS® communication : The ability to connect multiple devices through Modbus RTU interface (via RS485)

ARMONIA ARMONIA-ECM 7-8





## Air diffuser

Intake grids, frame and adjustable air distribution louvers on each side, made of ABS. In the **ARMONIA-ECM-MB** version the outlet louvers are adjustable with infra-red remote control or with DC65 wall control (for the **ARMONIA-ECM** version manually only).

The intake and air distribution grids are available with both, the G0 filter and the **ePM<sub>1</sub> 55% - F7 filter**.

## Inner casing

It is made of galvanized steel with internal thermal insulation with polyolefin (PO) foam (B-s2-d0 EN 13501-01) and external anti-condensate lining.

## Control devices

- **ARMONIA-ECM / ARMONIA-ECM-E** version  
It consists of the pump control circuit board and the inverter circuit board.

- **ARMONIA-ECM-MB / ARMONIA-ECM-MB-E** version

It consists of the MB electronic board (that integrates pump control) and the inverter board.

The diffusion louvers are adjustable with the infra-red remote control or with DC65 wall control.

## Fan assembly

The fan assembly, which is mounted on anti-vibrating supports, is extremely silent.

The radial fan has been designed to optimise performance, using wing profile blades with a shape that reduces turbulence, increasing efficiency and reducing noise.

The fans are connected to a three phase permanent magnet brushless electronic motor that is controlled with reconstructed current according to a BLAC sinusoidal wave.

The inverter board that controls the motor operation is powered by 230 Volt, single-phase and, with a switching system, it generates a three-phase frequency modulated, wave form power supply.

The electric power supply required for the machine is therefore single-phase with voltage of 230 V and frequency of 50 - 60 Hz.

## Coil

Made of copper tubes with bonded aluminium fins for maximum transfer contact.

3 row coil for 2 pipe models and 2,5 + 1/2 row coil for 4 pipe models (the heating row is on the inside part of the coil).

The coil is not suitable for use in corrosive atmosphere or in environments where aluminium may be subject to corrosion.

## Condensate collection tray

High density polystyrene foam condensate tray, shaped in order to optimize the air diffusion.

Fire retardant rating B1 to DIN 4102.

## Filter

Easy access to the filter that is available in both versions, in the G0 (synthetic regenerable washable) and in the ePM<sub>1</sub> 55% - F7 one (to change at the end of its life-cycle).

## Condensate drain pump

Float switch centrifugal pump with 650 mm of maximum head, integral to the unit and wired to the control panel on the outside of the casing.

The version with available pressure 1000 mm can be supplied on demand.

## Valve set

Two or three way valves for ON/OFF operation, with pipe mounting kit and ball valves.

## TECHNICAL FEATURES

### 2 pipe system

The following standard rating conditions are used:

#### COOLING

Entering air temperature: + 27 °C d.b. + 19 °C w.b.

Water temperature: +7 °C E.W.T. +12 °C L.W.T.

#### HEATING

Entering air temperature: + 20 °C

Water temperature: +45 °C E.W.T. +40 °C L.W.T.

MODEL	Inverter speed signal (Vdc)	ARMONIA-ECM 7-8 720					ARMONIA-ECM 7-8 820				
		1	3	5	7,5	10	1	3	5	7,5	10
Air flow	m <sup>3</sup> /h	790	1040	1290	1600	1905	1025	1340	1650	2060	2480
Cooling total emission	kW	6,36	7,95	9,43	11,10	12,60	7,86	9,72	11,38	13,35	15,13
Cooling sensible emission	kW	4,45	5,65	6,77	8,09	9,31	5,58	7,00	8,30	9,88	11,41
Heating emission	kW	6,18	7,93	9,59	11,55	13,39	8,72	9,91	11,86	14,29	16,40
Dp Cooling	kPa	6,6	9,8	13,4	18,0	22,7	9,6	14,1	18,8	25,2	31,8
Dp Heating	kPa	5,4	8,4	11,8	16,5	21,5	8,2	12,5	17,3	24,2	31,0
Sound power (Lw)	dB(A)	38	44	49	54	58	47	50	55	60	64
Sound pressure (Lp) <sup>(1)</sup>	dB(A)	29	35	40	45	49	38	41	46	51	55
Fan	W	13	22	35	59	93	21	38	64	113	183
Condensate drain pump power absorption	W	10	10	10	10	10	10	10	10	10	10
Water content	l	4,6	4,6	4,6	4,6	4,6	4,6	4,6	4,6	4,6	4,6
Length	mm	869	869	869	869	869	869	869	869	869	869
Depth	mm	869	869	869	869	869	869	869	869	869	869
Height	mm	304	304	304	304	304	304	304	304	304	304

<sup>(1)</sup> The sound pressure levels are 9 dB (A) lower than the sound power levels, apply to the reverberant field of a 100 m<sup>3</sup> room and a reverberation time of 0.5 sec.

### 4 pipe system

The following standard rating conditions are used:

#### COOLING

Entering air temperature: + 27 °C d.b. + 19 °C w.b.

Water temperature: +7 °C E.W.T. +12 °C L.W.T.

#### HEATING

Entering air temperature: + 20 °C

Water temperature: +65 °C E.W.T. +55 °C L.W.T.

MODEL	Inverter speed signal (Vdc)	ARMONIA-ECM 7-8 760					ARMONIA-ECM 7-8 860				
		1	3	5	7,5	10	1	3	5	7,5	10
Air flow	m <sup>3</sup> /h	790	1040	1290	1600	1905	1025	1340	1650	2060	2480
Cooling total emission	kW	6,07	7,53	8,86	10,35	11,61	7,45	9,10	10,59	12,30	13,59
Cooling sensible emission	kW	4,33	5,46	6,53	7,74	8,87	5,40	6,73	7,96	9,44	10,68
Heating emission	kW	6,01	7,27	8,40	9,63	10,55	7,19	8,62	9,80	11,05	12,17
Dp Cooling	kPa	7,0	10,3	13,8	18,3	22,6	10,1	14,5	19,1	25,2	30,4
Dp Heating	kPa	7,2	10,2	13,2	16,9	19,9	10,0	13,8	17,4	21,6	25,7
Sound power (Lw)	dB(A)	38	44	49	54	58	47	50	55	60	64
Sound pressure (Lp) <sup>(1)</sup>	dB(A)	29	35	40	45	49	38	41	46	51	55
Fan	W	13	22	35	59	93	21	38	64	113	183
Condensate drain pump power absorption	W	10	10	10	10	10	10	10	10	10	10
Cooling water content	l	3,6	3,6	3,6	3,6	3,6	3,6	3,6	3,6	3,6	3,6
Heating water content	l	1,2	1,2	1,2	1,2	1,2	1,2	1,2	1,2	1,2	1,2
Length	mm	869	869	869	869	869	869	869	869	869	869
Depth	mm	869	869	869	869	869	869	869	869	869	869
Height	mm	304	304	304	304	304	304	304	304	304	304

<sup>(1)</sup> The sound pressure levels are 9 dB (A) lower than the sound power levels, apply to the reverberant field of a 100 m<sup>3</sup> room and a reverberation time of 0.5 sec.

## COOLING EMISSION

Entering air temperature: 27 °C – R.H.: 50%

Model	Vdc	WT: 7 / 12 °C					WT: 8 / 13 °C					WT: 10 / 15 °C					WT: 12 / 17 °C				
		Qv m <sup>3</sup> /h	Pc kW	Ps kW	Qw l/h	Dp(c) kPa	Pc kW	Ps kW	Qw l/h	Dp(c) kPa	Pc kW	Ps kW	Qw l/h	Dp(c) kPa	Pc kW	Ps kW	Qw l/h	Dp(c) kPa			
ARMONIA-ECM 7-8720	10	1905	13,52	9,25	2341	25,7	12,21	8,73	2116	21,3	9,70	7,68	1684	14,0	6,96	6,96	1213	7,7			
	7,5	1600	11,90	8,07	2058	20,4	10,77	7,59	1862	16,9	8,58	6,69	1486	11,2	6,63	5,86	1150	7,0			
	5	1290	10,11	6,77	1744	15,1	9,14	6,36	1577	12,6	7,31	5,60	1264	8,3	5,65	4,90	978	5,2			
	3	1040	8,52	5,65	1470	11,1	7,74	5,32	1335	9,3	6,19	4,66	1068	6,2	4,77	4,08	825	3,8			
	1	790	6,80	4,45	1172	7,4	6,19	4,19	1067	6,2	4,99	3,68	860	4,2	3,85	3,22	665	2,6			
ARMONIA-ECM 7-8820	10	2480	16,21	11,31	2819	35,9	14,60	10,67	2543	29,7	11,59	9,41	2025	19,5	8,49	8,49	1491	11,1			
	7,5	2060	14,28	9,84	2476	28,5	12,92	9,28	2242	23,6	10,23	8,17	1779	15,4	7,39	7,39	1291	8,6			
	5	1650	12,18	8,27	2106	21,3	11,03	7,79	1907	17,7	8,74	6,85	1515	11,5	6,78	6,01	1177	7,2			
	3	1340	10,41	6,98	1797	16,0	9,43	6,57	1628	13,3	7,51	5,77	1299	8,8	5,81	5,06	1005	5,5			
	1	1025	8,42	5,58	1453	10,9	7,64	5,25	1318	9,1	6,13	4,61	1057	6,0	4,73	4,03	816	3,8			
ARMONIA-ECM 7-8760	10	1905	12,40	8,78	2149	25,5	11,20	8,31	1942	21,1	8,93	7,36	1553	13,9	6,65	6,65	1160	8,2			
	7,5	1600	11,03	7,69	1908	20,6	10,01	7,28	1731	17,2	7,97	6,43	1381	11,3	5,83	5,83	1013	6,4			
	5	1290	9,47	6,49	1635	15,6	8,57	6,11	1480	12,9	6,84	5,40	1183	8,6	5,32	4,75	921	5,4			
	3	1040	8,07	5,44	1391	11,6	7,30	5,13	1259	9,7	5,82	4,51	1005	6,4	4,53	3,97	782	4,0			
	1	790	6,50	4,32	1121	7,9	5,88	4,06	1014	6,6	4,73	3,57	816	4,4	3,67	3,14	634	2,8			
ARMONIA-ECM 7-8860	10	2480	14,48	10,52	2522	34,0	13,08	9,98	2281	28,2	10,41	8,85	1822	18,6	7,94	7,94	1396	11,4			
	7,5	2060	13,05	9,31	2264	28,0	11,81	8,82	2051	23,3	9,40	7,81	1635	15,3	7,04	7,04	1231	9,1			
	5	1650	11,27	7,87	1949	21,4	10,22	7,45	1768	17,8	8,13	6,58	1409	11,7	5,97	5,97	1038	6,7			
	3	1340	9,74	6,69	1681	16,4	8,82	6,30	1524	13,6	7,04	5,57	1217	9,0	5,47	4,90	947	5,7			
	1	1025	7,98	5,38	1376	11,4	7,22	5,07	1246	9,5	5,79	4,47	1000	6,3	4,48	3,92	774	3,9			

WT: Water temperature  
Vdc: Inverter speed signal (Vdc)  
Qv: Air flow  
Pc: Cooling total emission  
Ps: Cooling sensible emission  
Qw: Water flow rate  
Dp(c): Dp Cooling

Entering air temperature 26 °C – R.H.: 50%

Model	Vdc	WT: 7 / 12 °C					WT: 8 / 13 °C					WT: 10 / 15 °C					WT: 12 / 17 °C				
		Qv m <sup>3</sup> /h	Pc kW	Ps kW	Qw l/h	Dp(c) kPa	Pc kW	Ps kW	Qw l/h	Dp(c) kPa	Pc kW	Ps kW	Qw l/h	Dp(c) kPa	Pc kW	Ps kW	Qw l/h	Dp(c) kPa			
ARMONIA-ECM 7-8 720	10	1905	12,13	8,75	2102	21,2	10,85	8,19	1883	17,3	8,55	7,21	1487	11,2	6,39	6,39	1116	6,6			
	7,5	1600	10,67	7,61	1846	16,8	9,56	7,13	1655	13,7	7,57	6,28	1311	8,9	5,58	5,58	971	5,1			
	5	1290	9,07	6,38	1565	12,5	8,16	5,98	1410	10,3	6,45	5,25	1115	6,6	4,70	4,70	814	3,7			
	3	1040	7,67	5,33	1322	9,2	6,90	4,99	1190	7,6	5,46	4,38	943	4,9	4,17	3,82	721	3,0			
	1	790	6,13	4,21	1056	6,1	5,53	3,94	954	5,1	4,39	3,45	757	3,3	3,36	3,01	580	2,0			
ARMONIA-ECM 7-8 820	10	2480	14,49	10,67	2523	29,4	12,94	10,03	2257	23,9	10,26	8,85	1797	15,7	7,78	7,78	1370	9,5			
	7,5	2060	12,78	9,30	2218	23,3	11,44	8,72	1988	19,0	9,04	7,68	1574	12,4	6,79	6,79	1187	7,4			
	5	1650	10,93	7,80	1891	17,5	9,78	7,31	1694	14,3	7,72	6,43	1338	9,2	5,72	5,72	995	5,4			
	3	1340	9,35	6,59	1615	13,2	8,40	6,17	1451	10,8	6,63	5,42	1147	7,0	4,84	4,84	840	3,9			
	1	1025	7,58	5,27	1307	9,0	6,82	4,94	1176	7,4	5,40	4,32	932	4,8	4,12	3,77	713	2,9			
ARMONIA-ECM 7-8 760	10	1905	11,14	8,33	1932	21,0	9,94	7,83	1725	17,0	7,93	6,93	1380	11,3	6,10	6,10	1065	7,0			
	7,5	1600	9,95	7,30	1721	17,1	8,88	6,84	1538	13,9	7,04	6,04	1221	9,0	5,35	5,35	931	5,5			
	5	1290	8,52	6,13	1471	12,9	7,62	5,76	1317	10,5	6,03	5,07	1043	6,8	4,53	4,53	785	4,0			
	3	1040	7,25	5,15	1251	9,6	6,51	4,82	1124	7,9	5,15	4,24	889	5,1	3,80	3,80	658	2,9			
	1	790	5,85	4,08	1009	6,5	5,27	3,83	909	5,4	4,18	3,36	722	3,5	3,21	2,94	555	2,2			
ARMONIA-ECM 7-8 860	10	2480	13,03	10,00	2272	28,1	11,64	9,41	2033	22,9	8,61	8,61	1512	13,3	7,26	7,26	1280	9,7			
	7,5	2060	11,76	8,85	2042	23,2	10,50	8,31	1825	18,9	8,33	7,35	1452	12,4	6,45	6,45	1129	7,8			
	5	1650	10,16	7,47	1758	17,7	9,07	7,00	1571	14,4	7,17	6,19	1244	9,4	5,48	5,48	954	5,7			
	3	1340	8,77	6,34	1514	13,6	7,83	5,94	1353	11,0	6,19	5,23	1071	7,1	4,67	4,67	809	4,3			
	1	1025	7,17	5,08	1237	9,4	6,45	4,76	1112	7,7	5,11	4,20	882	5,0	3,76	3,76	650	2,9			

WT: Water temperature  
Vdc: Inverter speed signal (Vdc)  
Qv: Air flow  
Pc: Cooling total emission  
Ps: Cooling sensible emission  
Qw: Water flow rate  
Dp(c): Dp Cooling

Entering air temperature: 25 °C – R.H.: 50%

Model	Vdc	WT: 7 / 12 °C					WT: 8 / 13 °C					WT: 10 / 15 °C					WT: 12 / 17 °C				
		Qv m <sup>3</sup> /h	Pc kW	Ps kW	Qw l/h	Dp(c) kPa	Pc kW	Ps kW	Qw l/h	Dp(c) kPa	Pc kW	Ps kW	Qw l/h	Dp(c) kPa	Pc kW	Ps kW	Qw l/h	Dp(c) kPa			
ARMONIA-ECM 7-8720	10	1905	10,80	8,21	1874	17,2	9,64	7,70	1674	14,0	7,53	6,75	1310	8,9	5,82	5,82	1018	5,6			
	7,5	1600	9,51	7,15	1646	13,6	8,52	6,72	1476	11,1	6,63	5,87	1151	7,0	5,09	5,09	886	4,4			
	5	1290	8,11	6,00	1401	10,2	7,25	5,62	1254	8,3	5,65	4,92	977	5,2	4,29	4,29	744	3,2			
	3	1040	6,86	5,01	1184	7,5	6,13	4,69	1059	6,1	4,79	4,10	827	3,9	3,59	3,59	622	2,3			
	1	790	5,50	3,96	948	5,1	4,93	3,70	851	4,1	3,85	3,23	665	2,6	2,86	2,86	495	1,5			
ARMONIA-ECM 7-8820	10	2480	12,91	10,07	2251	24,0	11,54	9,45	2016	19,5	8,49	8,49	1492	11,2	7,07	7,07	1247	8,0			
	7,5	2060	11,41	8,73	1981	19,0	10,17	8,21	1769	15,4	7,40	7,40	1292	8,7	6,18	6,18	1082	6,2			
	5	1650	9,75	7,33	1688	14,3	8,70	6,88	1508	11,6	6,78	6,02	1177	7,3	5,22	5,22	908	4,5			
	3	1340	8,35	6,19	1442	10,8	7,46	5,80	1290	8,7	5,81	5,07	1006	5,5	4,43	4,43	768	3,4			
	1	1025	6,79	4,95	1171	7,4	6,08	4,64	1050	6,0	4,73	4,05	818	3,8	3,55	3,55	615	2,3			
ARMONIA-ECM 7-8760	10	1905	9,94	7,84	1726	17,2	8,89	7,38	1545	14,0	6,65	6,65	1160	8,3	5,54	5,54	969	5,9			
	7,5	1600	8,82	6,86	1528	13,8	7,91	6,44	1370	11,3	5,84	5,84	1014	6,5	4,87	4,87	848	4,6			
	5	1290	7,59	5,77	1311	10,5	6,81	5,42	1177	8,6	5,32	4,76	921	5,4	4,13	4,13	716	3,4			
	3	1040	6,49	4,84	1119	7,9	5,78	4,54	999	6,4	4,53	3,98	782	4,1	3,47	3,47	601	2,5			
	1	790	5,24	3,84	903	5,3	4,69	3,59	809	4,4	3,68	3,15	635	2,8	2,78	2,78	481	1,7			
ARMONIA-ECM 7-8860	10	2480	11,61	9,42	2028	22,9	10,38	8,87	1816	18,7	7,93	7,93	1396	11,5	6,58	6,58	1163	8,2			
	7,5	2060	10,47	8,31	1821	18,9	9,36	7,83	1629	15,4	7,05	7,05	1231	9,2	5,86	5,86	1027	6,6			
	5	1650	9,03	7,01	1564	14,4	8,07	6,59	1399	11,7	5,97	5,97	1039	6,8	4,99	4,99	869	4,8			
	3	1340	7,79	5,95	1347	11,0	6,99	5,59	1209	9,0	5,48	4,91	948	5,7	4,25	4,25	738	3,6			
	1	1025	6,41	4,78	1106	7,7	5,72	4,48	988	6,2	4,48	3,93	774	4,0	3,43	3,43	594	2,4			

WT: Water temperature  
Vdc: Inverter speed signal (Vdc)  
Qv: Air flow  
Pc: Cooling total emission  
Ps: Cooling sensible emission  
Qw: Water flow rate  
Dp(c): Dp Cooling

HEATING EMISSION

Entering air temperature: 20 °C

Model	Vdc	WT: 65 / 55 °C				WT: 60 / 50 °C			WT: 50 / 40 °C			WT: 50 / 45 °C			WT: 45 / 40 °C		
		Qv m³/h	Ph kW	Qw l/h	Dp(h) kPa	Ph kW	Qw l/h	Dp(h) kPa	Ph kW	Qw l/h	Dp(h) kPa	Ph kW	Qw l/h	Dp(h) kPa	Ph kW	Qw l/h	Dp(h) kPa
ARMONIA-ECM 7-8 720	10	1905	24,08	2070	17,0	21,08	1813	13,5	15,06	1295	7,6	16,34	2810	30,4	13,39	2302	21,5
	7,5	1600	20,78	1787	13,0	18,21	1566	10,4	13,05	1122	5,9	14,08	2421	23,2	11,55	1987	16,5
	5	1290	17,25	1483	9,3	15,14	1302	7,5	10,90	937	4,2	11,67	2007	16,6	9,59	1649	11,8
	3	1040	14,26	1226	6,6	12,54	1078	5,3	9,06	779	3,0	9,63	1656	11,7	7,93	1363	8,4
	1	790	11,12	956	4,2	9,79	842	3,4	7,11	611	2,0	7,49	1289	7,5	6,18	1063	5,4
ARMONIA-ECM 7-8 820	10	2480	29,49	2536	24,4	25,79	2218	19,4	18,33	1577	10,8	20,06	3450	43,9	16,40	2821	31,0
	7,5	2060	25,69	2210	19,1	22,49	1934	15,2	16,04	1379	8,5	17,45	3001	34,2	14,29	2457	24,2
	5	1650	21,33	1834	13,6	18,69	1608	10,9	13,39	1151	6,1	14,45	2486	24,4	11,86	2039	17,3
	3	1340	17,83	1533	9,9	15,65	1346	7,9	11,25	968	4,5	12,06	2075	17,6	9,91	1705	12,5
	1	1025	14,08	1211	6,5	12,38	1064	5,2	8,94	769	3,0	9,50	1635	11,5	7,82	1346	8,2

WT: Water temperature  
 Vdc: Inverter speed signal (Vdc)  
 Qv: Air flow  
 Ph: Heating emission  
 Qw: Water flow rate  
 Dp(h): Dp Heating

Entering air temperature: 20 °C

Model	Vdc	WT: 70 / 60 °C				WT: 60 / 50 °C			WT: 50 / 40 °C			WT: 50 / 45 °C			WT: 45 / 40 °C		
		Qv m³/h	Ph kW	Qw l/h	Dp(h) kPa	Ph kW	Qw l/h	Dp(h) kPa	Ph kW	Qw l/h	Dp(h) kPa	Ph kW	Qw l/h	Dp(h) kPa	Ph kW	Qw l/h	Dp(h) kPa
ARMONIA-ECM 7-8 760	10	1905	12,04	1036	24,9	9,07	780	15,3	6,10	525	7,7	7,36	1266	37,4	5,89	1014	25,5
	7,5	1600	10,98	944	21,1	8,28	712	13,0	5,58	480	6,6	6,71	1155	31,7	5,38	925	21,6
	5	1290	9,58	824	16,5	7,23	621	10,2	4,88	420	5,2	5,85	1007	24,8	4,69	807	16,9
	3	1040	8,28	712	12,7	6,25	538	7,9	4,23	364	4,0	5,06	870	19,1	4,06	698	13,0
	1	790	6,84	588	9,0	5,17	445	5,6	3,51	301	2,9	4,18	719	13,5	3,35	577	9,2
ARMONIA-ECM 7-8 860	10	2480	13,89	1195	32,3	10,45	899	19,8	7,02	604	10,0	8,50	1461	48,5	6,80	1169	32,9
	7,5	2060	12,61	1085	27,1	9,49	817	16,7	6,39	549	8,4	7,71	1326	40,7	6,17	1062	27,7
	5	1650	11,18	961	21,8	8,42	724	13,4	5,68	488	6,8	6,83	1176	32,8	5,48	942	22,3
	3	1340	9,83	845	17,3	7,41	637	10,7	5,00	430	5,4	6,00	1033	25,9	4,81	828	17,7
	1	1025	8,20	705	12,5	6,19	532	7,7	4,19	360	3,9	5,01	862	18,7	4,02	691	12,8

WT: Water temperature  
 Vdc: Inverter speed signal (Vdc)  
 Qv: Air flow  
 Ph: Heating emission  
 Qw: Water flow rate  
 Dp(h): Dp Heating

**WATER SIDE PRESSURE DROP**

**2 pipe system**

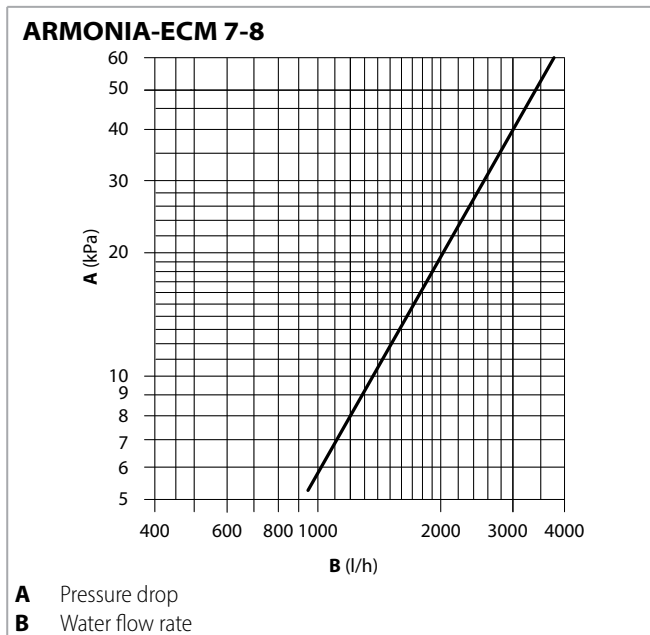

The water pressure drop figures refer to a mean water temperature of 10 °C; for different temperatures, multiply the pressure drop figures by the correction factors K.

K correction factor	Mean water temperature (°C)						
	20	30	40	50	60	70	80
	0,94	0,90	0,86	0,82	0,78	0,74	0,70

**4 pipe system**

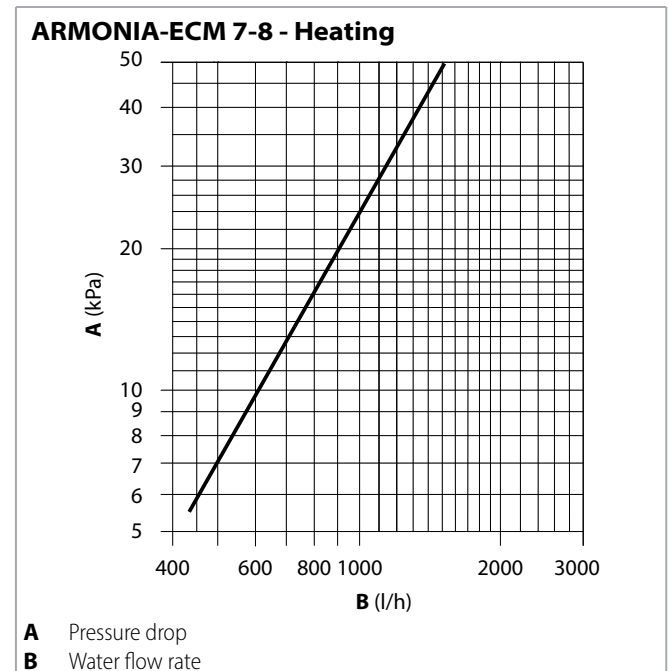
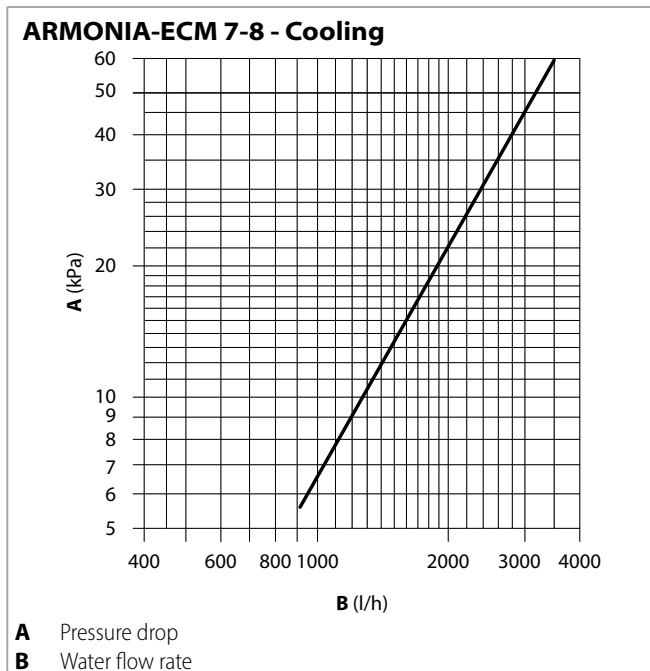

The water pressure drop figures refer to a mean water temperature of 10 °C; for different temperatures, multiply the pressure drop figures by the correction factors K.

K correction factor	Mean water temperature (°C)						
	20	30	40	50	60	70	80
	0,94	0,90	0,86	0,82	0,78	0,74	0,70

The water pressure drop figures refer to a mean water temperature of 60 °C; for different temperatures, multiply the pressure drop figures by the correction factors K.

K correction factor	Mean water temperature (°C)			
	40	50	70	80
	1,12	1,06	0,94	0,88

**OPERATION LIMITS**

Description	UoM	Value	
Water flow	Max. water side pressure	bars	10
		kPa	1000
	Lowest water inlet temperature	°C	+6
	Highest water inlet temperature mod. 720 820	°C	+65
	Highest water inlet temperature mod. 760 860	°C	+80
Power supply	Single-phase rated operating voltage	V/Hz	230/50-60

For maximum installation height, see p. 45.

**Filter**

**ePM<sub>1</sub> 55% - F7 filter**

Micro-pleated synthetic filter dimension 578x578x24 mm.

surface increases the emissions and reduces the pressure drops.

The filtering media is made of (PP+PS) polystyrene and polypropilene. The very big micro-pleated filtering

Air flow Qv (m <sup>3</sup> /h)	700	1000	1300	1600	1900	2200
Efficiency	70%	70%	65%	65%	55%	55%



**DIMENSION AND WEIGHT**

**ARMONIA-ECM 720 760 / ARMONIA-ECM 820 860**

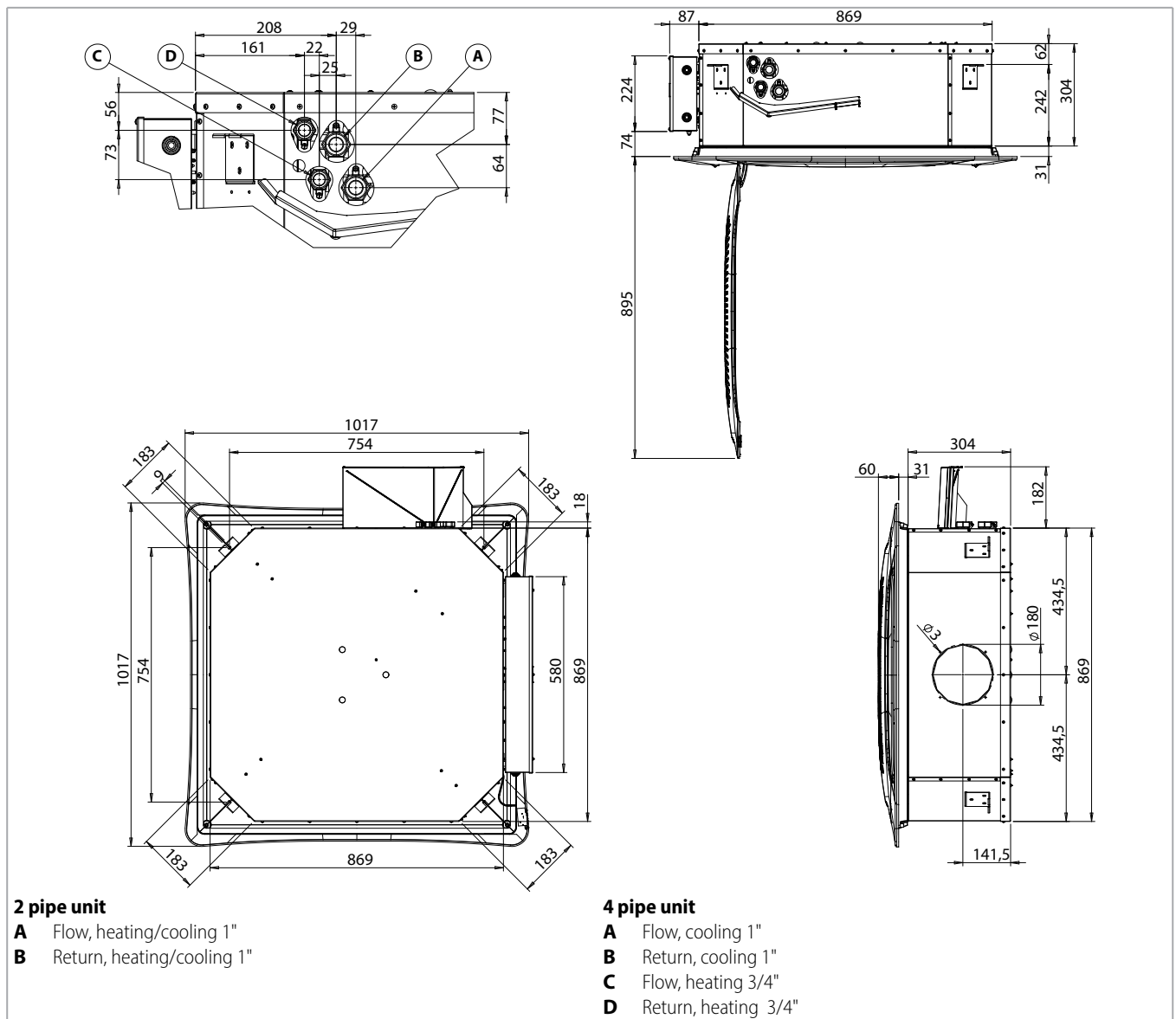

**Packed unit**

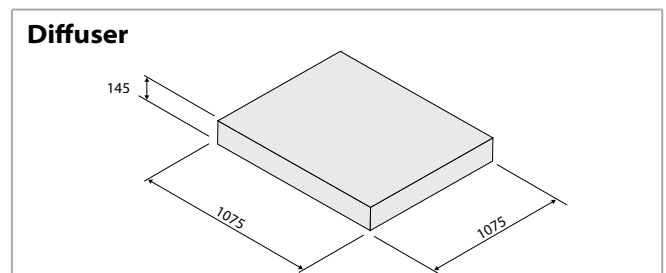
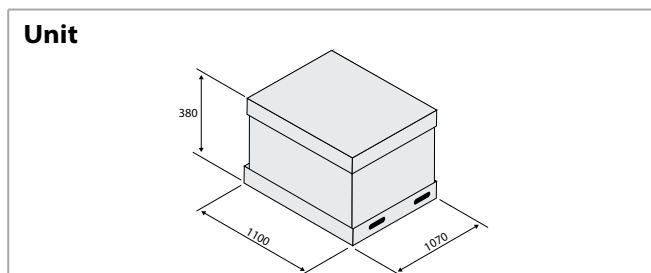

Weight/Model		720	760	820	860
With packaging	kg			52	
Without packaging	kg			42	

Weight/Model		720	760	820	860
With packaging	kg			9,4	
Without packaging	kg			7,5	

**AIR THROW**

The air throw indicated in the tables must only be considered the maximum value, as it may change significantly in relation to the dimensions of the room in which the appliance is installed and the positioning of the furniture in the room.

The useful throw L refers to the distance between the unit and the point where the air speed is 0.2 m/sec; if the louver has a gradient of 40° (recommended in cooling mode), the so-called "coanda" effect will occur, illustrated in the first figure, while at a gradient of 60°

(recommended in heating mode), there will be a downwards throw, as illustrated in the second figure.

**Note:** on heating it must be paid attention to rooms where the floor temperature is particularly low (for example less than 5 °C). In this situation the floor can cool the lower layer of air to a level that stops the uniform diffusion of the hot air coming from the unit, decreasing the throw figures shown in the table.

**With adjustable air diffusion louvers at 40°**

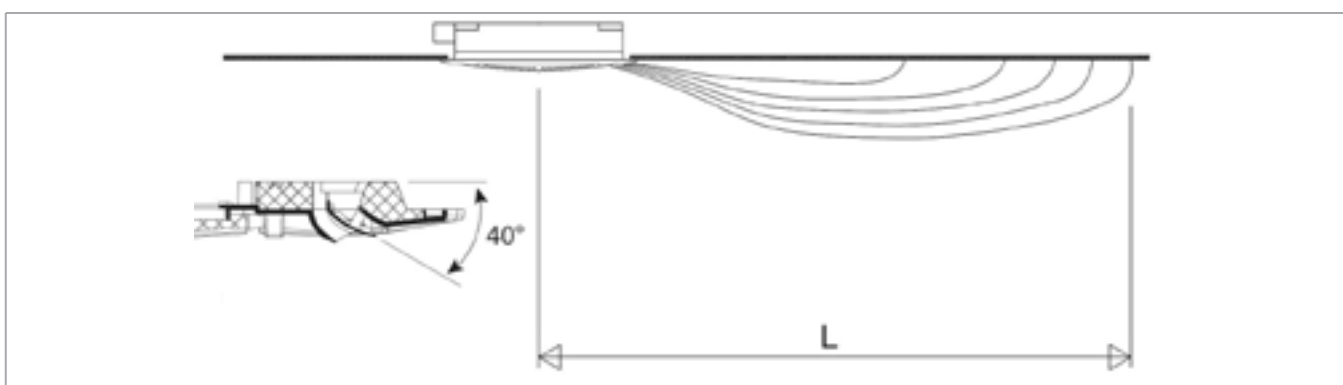

Model		ARMONIA-ECM 720 760			ARMONIA-ECM 820 860		
Vdc		1	5	10	1	5	10
L	m	3,5	5,0	6,5	4,0	6,0	7,5

Vdc = Inverter speed signal

**With adjustable air diffusion louvers at 60°**

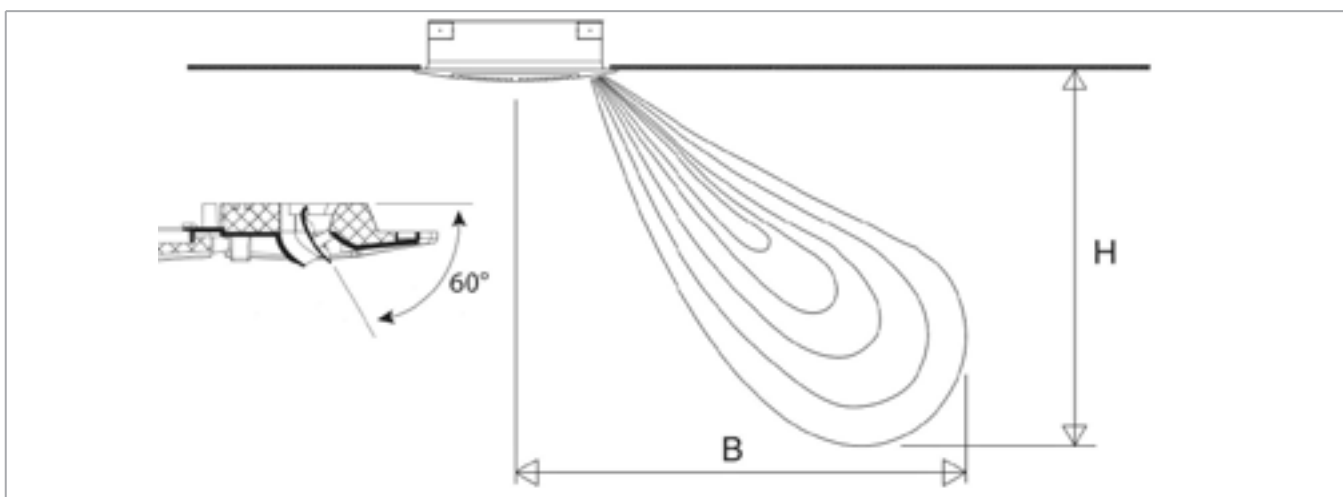

Model		ARMONIA-ECM 720 760			ARMONIA-ECM 820 860		
Vdc		1	5	10	1	5	10
H	m	3,1	3,6	4,1	3,5	4,0	4,7
B	m	3,5	4,5	5,5	4,0	5,0	6,5

Vdc = Inverter speed signal

## CONTROLS FOR ARMONIA-ECM UNITS

### ARMONIA-ECM version

For this cassette configuration, the 1-10 Vdc speed signal, which controls the inverter, must be supplied by a controller with the following signal specifications:

### Fan coil control signal

- Fan OFF = 0 Vdc
- Fan ON > 1 Vdc
- Max. speed = 10 Vdc

### ECM Blac inverter board

- 0÷10 Vdc Circuit Input Impedance Value = 96 kOhm

### Power supply

230Vac 1Ph 50-60Hz

### Controls

All the units of the **ARMONIA ECM 7-8** range can be supplied with a wide range of controls that allows managing one single unit or several units (with the use of the power units).

The room temperature can be controlled through wall electronic room thermostats, with different solutions according to every ambient conditions.

The **AWUP**, **DC65** and **RCFZ** electronic thermostats control the room temperature precisely and are suitable when the user wants to set the fan speed.

**Note:** all the controls are described in detail in the "Fan Coil Control Range literature".

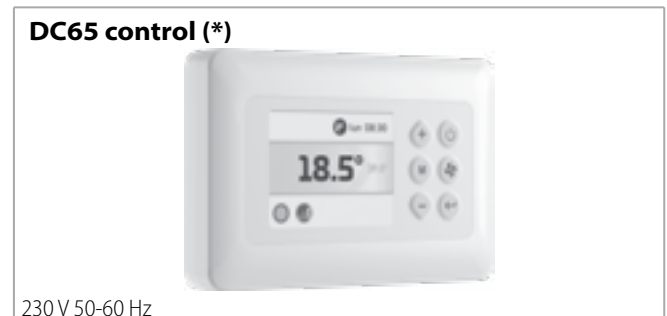
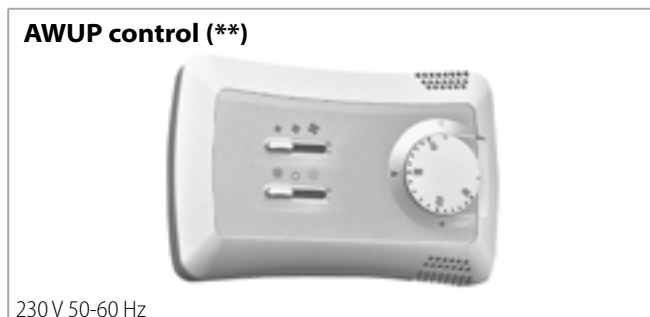

(\*\*) To be used with MB card.  
(\*\*) To be used with TOAI.

### Control systems

See from p. 49 for:

- the MB electronic board (to be fitted on the MB version)
- the MB controls and units

### NTC probe with receiver for infra-red remote control

ID	Code
WM-NTC	9079885

The WM-NTC probe to be used only with the MB board for ARMONIA ARMONIA-ECM-MB 7-8 unit, is a control for concealed installation (box interaxle spacing 60 mm) for room temperature control.

This control with fitted NTC probe lets the prevention from stratification problems.



### Technical characteristics

- On/off switch for the fan coil unit
- Manual and automatic 3 speed switch
- Internal probe for room temperature detection
- Receiver for infra-red remote control

With the dip-switches it is possible to select the following operating functions:

- Room temperature cut-out thermostat only
- ON/OFF switch
- ON/OFF and speed change switches
- Operating mode with receiver for infra-red remote control for MBIE infra-red remote control

The WM-NTC probe can be used as stand-alone or master/slave.

## ARMONIA-ECM-E VERSION

The 2 pipe model Cassette units are available with electric heater.

The electric heater is controlled in place of the hot water valve and not as integration to it.

The electric heaters are hermetically sealed and supplied inside the coil pipes and therefore can be only factory mounted.

The electric heaters of the unit can be for 230Vac 1Ph 50-60Hz or 400Vac 3Ph 50-60Hz supply.

The Cassette fan coil unit includes no. 2 safety thermostats which intervene in case of internal over-heating, opening an auxiliary power relay (included in the electrical panel) which stops the power supply to the electric heaters.

Note: the cooling emission of the units is 95% of the emission in the tables of page p. 38.

Model		ARMONIA-ECM 7-8 720	ARMONIA-ECM 7-8 820
Nominal installed power	W		3000
Single-phase rated operating voltage	Vac/Ph/Hz		230/1/50
Rated three phase connection	Vac/Ph/Hz		400/3/50
Connecting wires	n x mm <sup>2</sup>		3 x 2,5
Maximum single-phase current absorbed	A		13,5
Maximum three-phase current absorbed	A		4,5
Single-phase advised fuse <sup>(1)</sup>	A		16
Three-phase advised fuse <sup>(1)</sup>	A		6
Max. ambient temperature <sup>(2)</sup>	°C		25

<sup>(1)</sup> for the overload protection; gG type

<sup>(2)</sup> with electric heater in heating mode

## ARMONIA-ECM-E controls

### AWUP control (\*)



### DC65 control (\*\*)



230 V 50-60 Hz

(\*) To be used with TOAI

(\*\*) To be used with MB card.

## CONTROLS

### MB electronic board

The MB electronic board, to be mounted on the **ARMONIA-MB**, **ARMONIA-ECM-MB** and **ARMONIA-ECM-MB-E** versions, is set to carry out different functions and adjustment modes, in order to meet the installation requirements.

The Dip Switches on the board have to be set to carry out different functions:

- 2/4 pipe unit
- electronic room thermostat or automatic fan speed modulation for fan control (ON-OFF)
- electronic room thermostat for valve control (ON-OFF) (the fan keeps working)
- simultaneous thermostatic control of the valves and fan
- fan operation control depending on the coil temperature (fitted T3 low temperature cut-out thermostat), which can be activated only in heating mode or heating and cooling mode
- automatic switch of the operating mode by means of SAT2 water probe (optional) applied on the 2 pipe system
- Summer/Winter switch by means of remote contact
- ON/OFF of the fan coil by means of the remote contact (window or clock contact)
- electric heater control

By activating the T3 low temperature cut-out thermostat function, the fan is stopped in winter when the coil temperature is lower than 32 °C and started when the temperature reaches 36 °C. In summer mode, the fan stops when inside the coil exceeds 22 °C and starts when it drops below 18 °C.

The following connections are located on the power board:

- receiver for infra-red remote control
- DC65 wall control
- serial connection to manage several fan coil units in Master/Slave configuration or to create a supervisory network.

**ARMONIA / ARMONIA ECM**



**ARMONIA ECM 7-8**



## MB controls and units

All the units **ARMONIA**, **ARMONIA ECM** and **ARMONIA ECM 7-8** can be supplied in **MB** version. This version includes a wide range of controls, including the infra-red remote control, which allows managing one single unit or one or more groups of units by using the Modbus RTU - RS 485 communication protocol.

The groups of units can be managed according to the Master/Slave logic (up to 20 units) or by supervisory components.

The system includes a single MB power board and a range of technical devices to be used with:

- the **DC65** wall control and the **MBIE infra-red remote control** to manage single units;

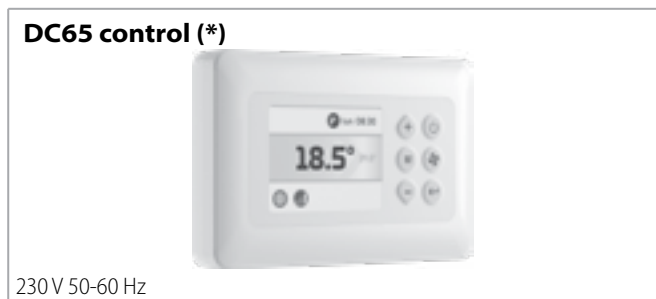

With the PSM-DI multifunction control panel it is possible to manage up to 60 units that are equipped with MB electronic board or IORN (max. 60 units: IORN + MB). The PSM-DI multifunction control panel supervises via Bus network all the connected units. The remote connection (stand-alone) is not possible.



## FRESH AIR AND CAP ACCESSORY

### Fresh air

**To be used with ARMONIA 0-1-2-3 models only.**

The ARMONIA cassette is fitted with inlets for fresh air to be mixed with return air inside the unit.

The fresh air flow is limited to 20% of the total fan coil air flow at medium speed and 100 m<sup>3</sup>/h for each treated air inlet.

The units feature fresh air inlets on three corners (no inlets on the fourth corner because of the condensate pump inside the unit).

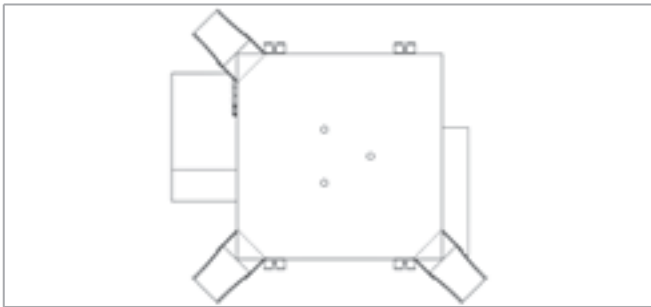

The fresh air inlets are designed for the insertion of standard 110x55 mm rectangular ducts or for the circular ducts fresh air connection CAP below illustrated.

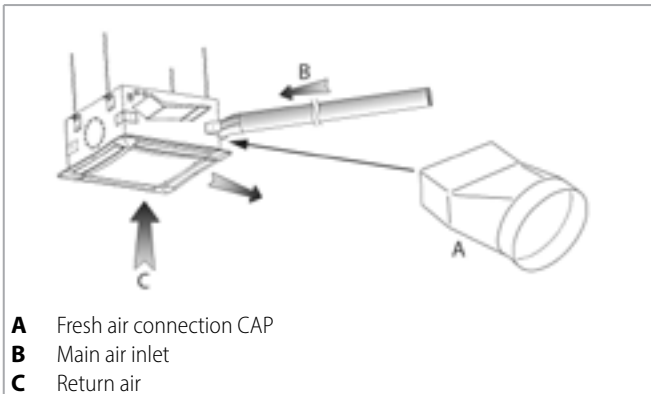

The fresh air is conveyed into the radial fan and mixed to the return air.

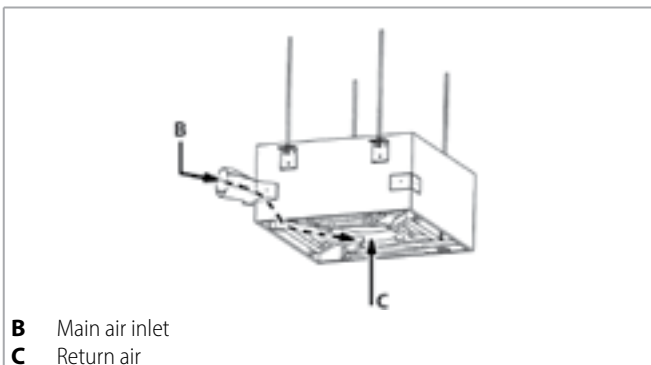

### Fresh air connection

Not suitable for MCT models with outer casing.

Model	ID	Code
0-1-2-3	CAP	6078005

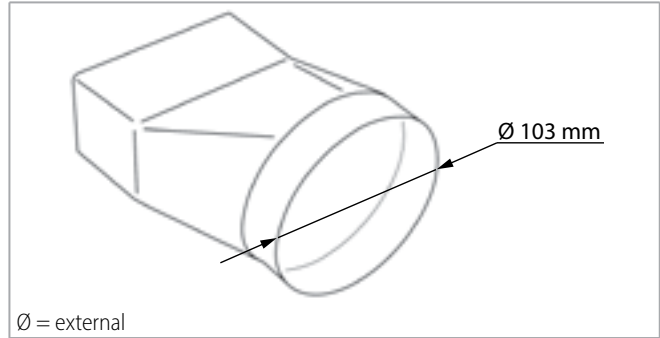

The air duct is connected quickly and easily. After removing the blank and the insulation inside the unit, the mounting plate is rolled back and the air duct with its V-shaped section must be pushed into the unit. The duct is then fixed to the mounting plate.

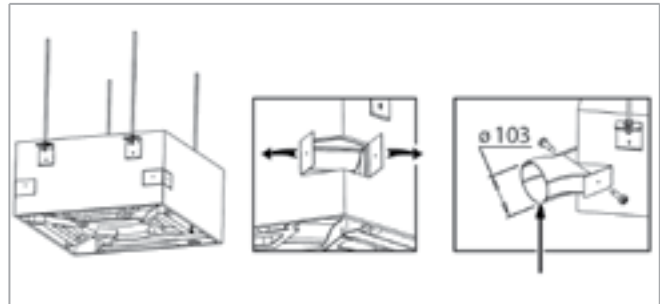

Note: the fresh air must be filtered.

**ACCESSORIES**

**Air distribution connection**

Not suitable for MCT models with outer casing.

Model	ID	Code
0-1-2-3	CDA 600	9079232
4-5-6-7-8	CDA 800	9079233

On Cassette fan coils two air outlets are provided on the side of the unit for connection to separate supply air outlets. The total air flow does not change.

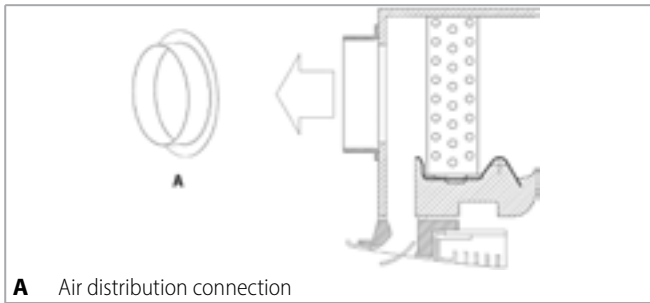

The air distribution connection diameters are:

Model	0-1-2-3	4-5-6-7-8	
∅ fitting	mm	150	180

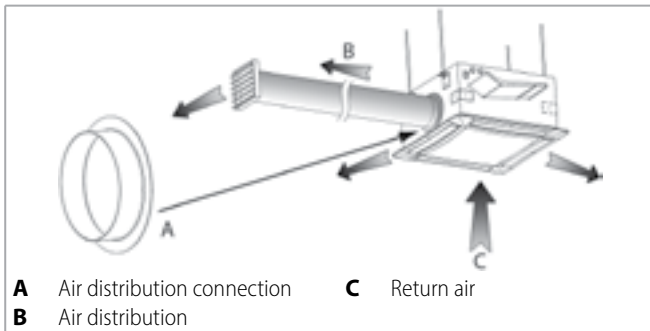

The air flow at high speed depending on the air duct pressure drop is shown in the tables below.

**Note:** all air ducts must be insulated in order to avoid condensation.

**Air distribution connection pressure drop**

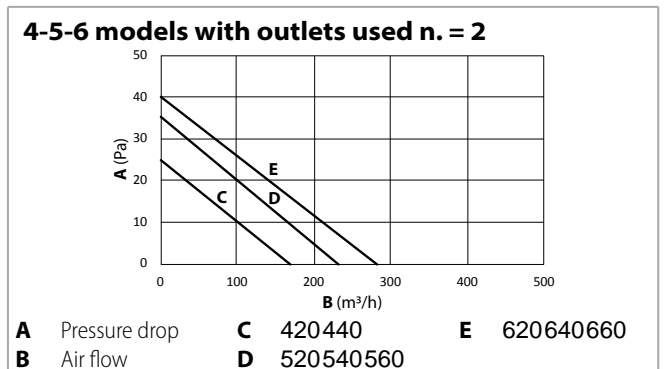
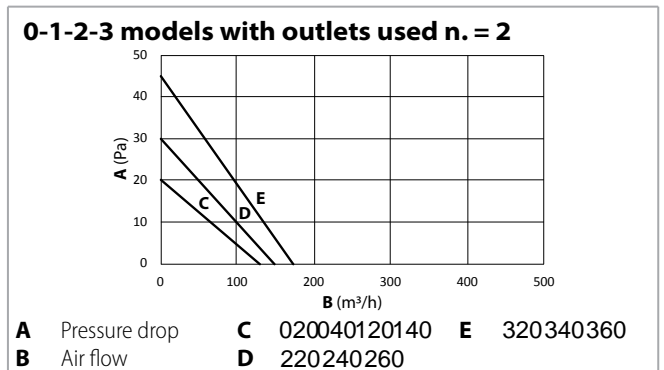
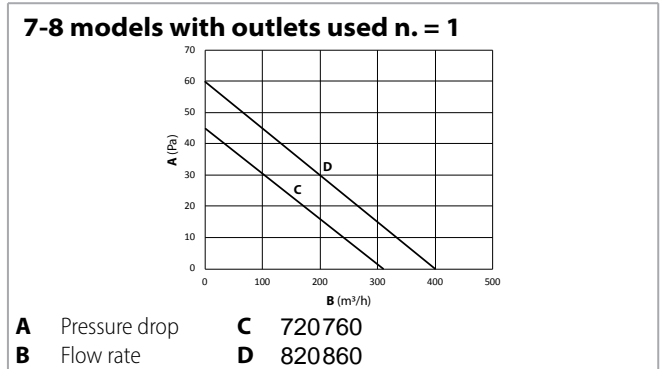
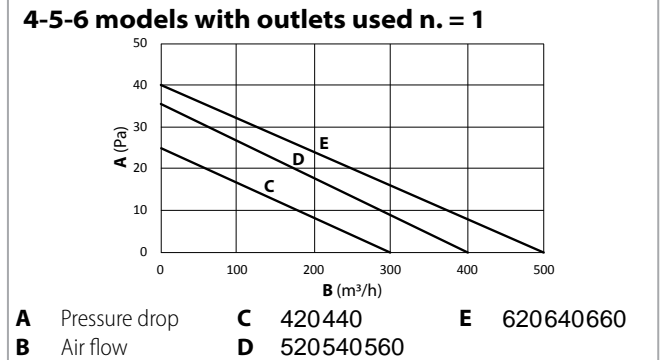
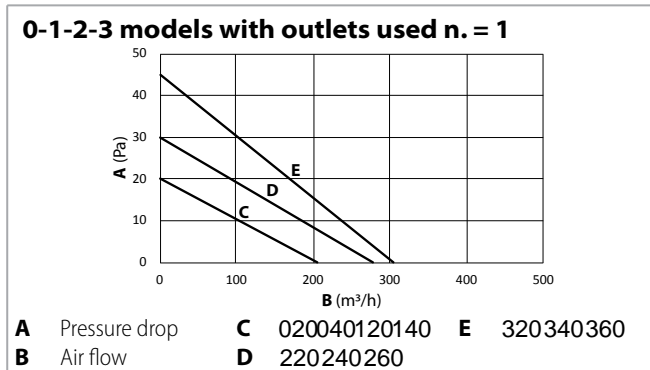

## Fresh air kit

Not suitable for MCT models with outer casing.

Model	Code
0-1-2-3	9079230
4-5-6	9079231
7-8	9079235

This is used to introduce fresh air into the environment directly through the diffuser.

The kit includes a flow separator to be fitted inside the cassette, and a circular fitting for connection to the flexible system ducting.

The flow of air is sent directly to just one of the outlet louvers, without passing through the coil. The air flow of fresh air introduced into the environment depends on the inlet static pressure.

The fresh air kit diameters are:

Model		0-1-2-3	4-5-6-7-8
Ø fitting	mm	150	180

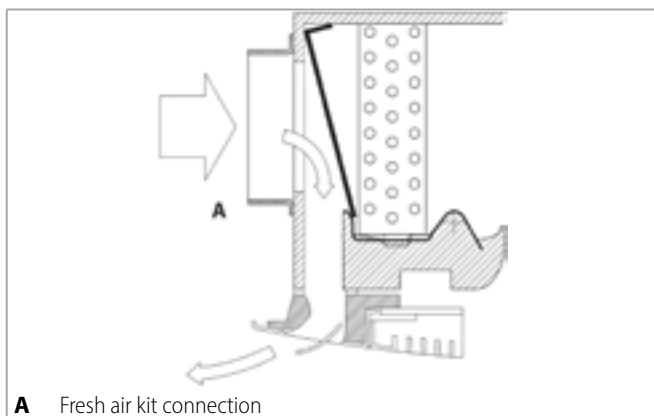

## Correlation between flow-rate / Static pressure

### Models 0-1-2-3

Flow rate	m <sup>3</sup> /h	80	120	160	200	240
Static pressure	Pa	3	8	15	25	36

### Models 4-5-6-7-8

Flow rate	m <sup>3</sup> /h	160	200	300	400	500
Static pressure	Pa	3	8	15	25	36

## Units with remote electric board

Factory mounted on standard units **ARMONIA** without MB electronic board.

It can not be fitted on ECM versions.

Model	Code
0-1-2-3-4-5-6	on request

On request the **ARMONIA** cassettes are available with electric control panel reachable from below and with the electric board that can be placed in a remote position.

In this case the units are supplied with an electronic connecting control panel, fitted to the bottom side on the 4 smallest sizes and to the lateral side on the 3 biggest sizes.

The electronic control panel is connected to the fan motor, to the condensate pump and to the condensate level control.

A 6 m wire is also supplied with integral plug-in connections to connect the unit with the remote electric board that can be installed in a suitable and comfortable position, where the power and system connections can be made easily.

This feature is not available for units with electric heater or infrared remote control.

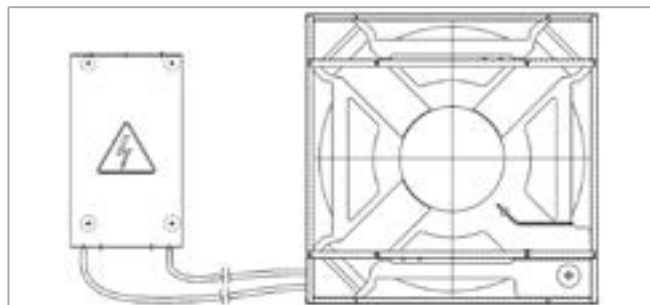

## Unit with condensate pump with higher pressure head

Factory mounted on all models ARMONIA ARMONIA.

Model	Code
0-1-2-3	9079160
4-5-6	9079162
7-8	9079164

On demand it is possible to order each fan coil Cassette TopLine with condensate pump with available pressure 1000 mm.

**Kit for hydraulic and electrical connections on the same side**

Not applicable for:

- versions with electric heater
- unit with electrostatic filter
- ARMONIA ECM version 7-8

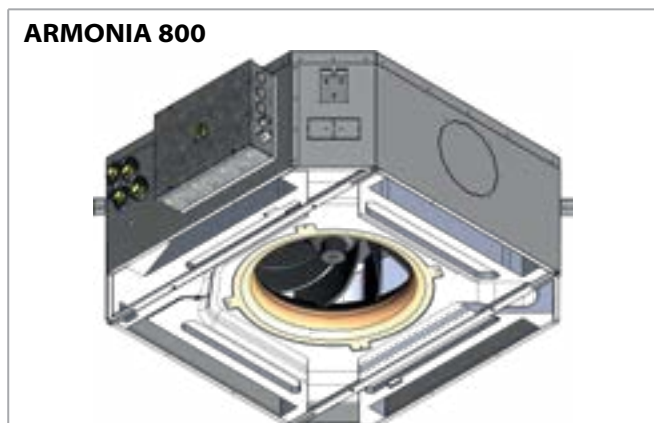

The kit is supplied only factory mounted.

The kit can not be used with valve standard kits from p. 55.

**Kit for hydraulic and electrical connections on the same side for ARMONIA version**

**ARMONIA version without MB board**

Model	Code
ARMONIA 0	9K79050
ARMONIA 1	9K79051
ARMONIA 2	9K79052
ARMONIA 3	9K79053
ARMONIA 4	9K79054
ARMONIA 5	9K79055
ARMONIA 6	9K79056

**ARMONIA version with MB board**

Model	Code
ARMONIA-MB 0	9K79060
ARMONIA-MB 1	9K79061
ARMONIA-MB 2	9K79062
ARMONIA-MB 3	9K79063
ARMONIA-MB 4	9K79064
ARMONIA-MB 5	9K79065
ARMONIA-MB 6	9K79066

**Kit for hydraulic and electrical connections on the same side for ARMONIA-ECM version (not to be used with SkyStar Jumbo)**

**ARMONIA ECM version without MB board**

Model	Code
ARMONIA-ECM 1÷3	9K79081
ARMONIA-ECM 4-5	9K79084

**ARMONIA ECM version with MB board**

Model	Code
ARMONIA-ECM MB 1÷3	9K79091
ARMONIA-ECM MB 4-5	9K79094

**ARMONIA version with UP-AU board fitted on the unit**

Model	Code
ARMONIA-ECM 1÷3	9K79101
ARMONIA-ECM 4-5	9K79104

### 3 ways ON-OFF valves with actuator with interception valve

Valve kit with 3 ways ON-OFF valves and with thermoelectric actuator; the kit includes connection pipes.

### 3 ways valves + micrometric lockshield valve connection kit - ARMONIA ARMONIA and ARMONIA ARMONIA-ECM

Model	Valve fitted on the unit Code	Valve not fitted on the unit Code	Coil	Micrometric lockshield valve connections ø (female)	Kvs m <sup>3</sup> /h	Dp max kPa*
020 120 220 320	9079510	9079500	main	1/2"	2,5	50
420 520 620	9079511	9079501	main	3/4"	4,5	50
040 140 240 260 340 360	9079512	9079502	main	1/2"	2,5	50
			secondary	1/2"	2,5	50
440 540 560 640 660	9079513	9079503	main	3/4"	4,5	50
			secondary	1/2"	2,5	50

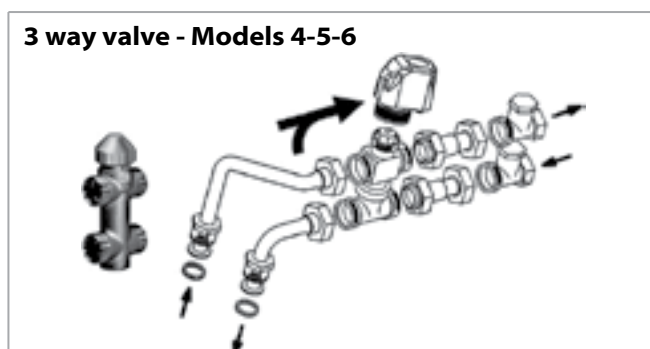
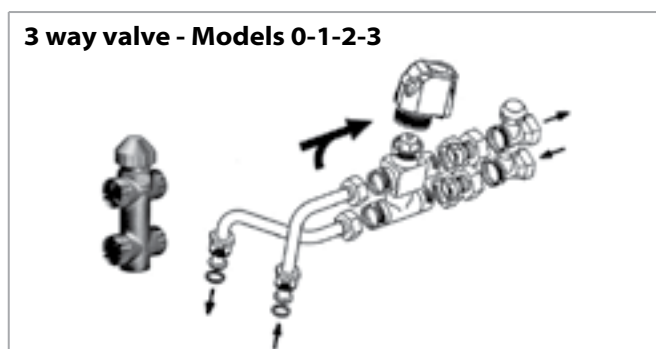

### 3 ways valves + ball valves connection kit - ARMONIA ARMONIA-ECM 7-8

Model	Valve fitted on the unit Code	Valve not fitted on the unit Code	Coil	Ball valve connections ø (male)	Kvs m <sup>3</sup> /h	Dp max kPa*
720 820	9079923W	9079922W	main	1"	4,5	50
760 860	9079933W	9079932W	main	1"	4,5	50
			secondary	3/4"	2,5	50

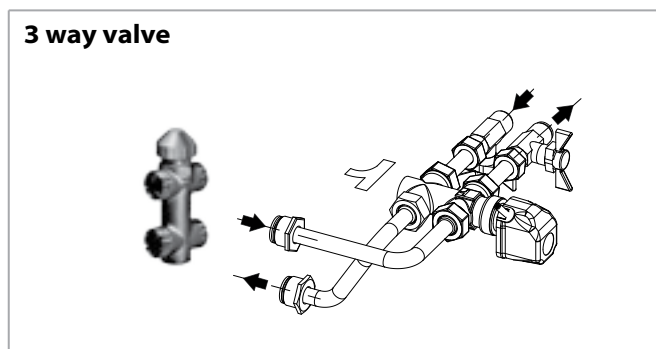

For technical data, operation limits and valves pressure drop, see p. 59

**2 ways ON-OFF valves with actuator with interception valve**

Valve kit with 2 ways ON-OFF valves and with thermoelectric actuator; the kit includes connection pipes.

**2 ways valves + micrometric lockshield valve connection kit - ARMONIA ARMONIA and ARMONIA ARMONIA-ECM**

Model	Valve fitted on the unit Code	Valve not fitted on the unit Code	Coil	Micrometric lockshield valve connections ø (female)	Kvs m <sup>3</sup> /h	Dp max kPa*
020 120 220 320	9079515	9079505	main	1/2"	2,8	50
420 520 620	9079516	9079506	main	3/4"	4,5	60
040 140 240 260 340 360	9079517	9079507	main	1/2"	2,8	50
			secondary	1/2"	2,8	50
440 540 560 640 660	9079518	9079508	main	3/4"	4,5	60
			secondary	1/2"	2,8	50

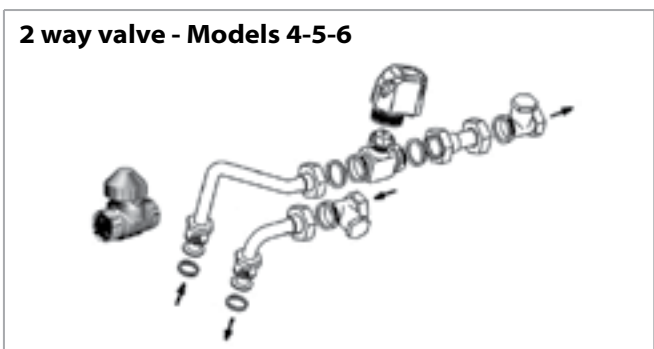
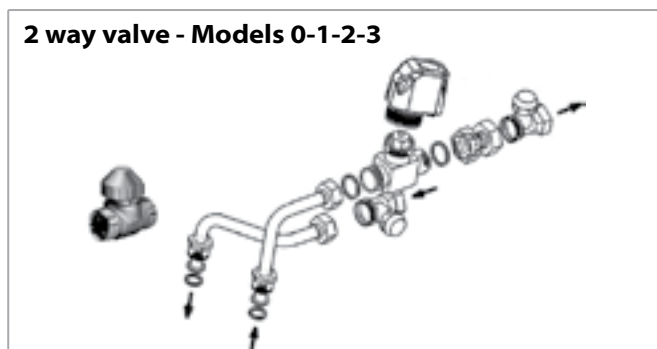

**2 ways valves + ball valves connection kit - ARMONIA ARMONIA-ECM 7-8**

Model	Valve fitted on the unit Code	Valve not fitted on the unit Code	Coil	Ball valve connections ø (male)	Kvs m <sup>3</sup> /h	Dp max kPa*
720 820	9079921W	9079920W	main	1"	4,5	60
760 860	9079931W	9079930W	main	1"	4,5	60
			secondary	3/4"	2,8	50

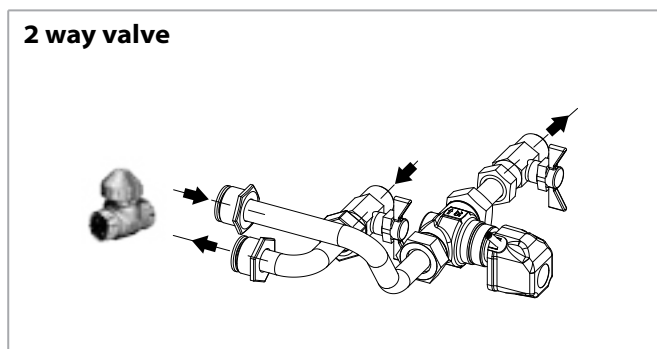

For technical data, operation limits and valves pressure drop, see p. 59

### 3 ways ON-OFF valves with actuator, without interception valve

Valve kit with 3 ways ON-OFF valves and with thermoelectric actuator; the kit includes connection pipes.

### 3 ways valves + simplified connction kit - ARMONIA ARMONIA and ARMONIA ARMONIA-ECM

Model	Coil	Valve connection ø (male)	Kvs m <sup>3</sup> /h	Dp max kPa*
020 120 220 320	main	3/4"	2,5	50
420 520 620	main	1"	4,5	50
040 140 240 260 340 360	main	3/4"	2,5	50
	secondary	3/4"	2,5	50
440 540 560 640 660	main	1"	4,5	50
	secondary	3/4"	2,5	50

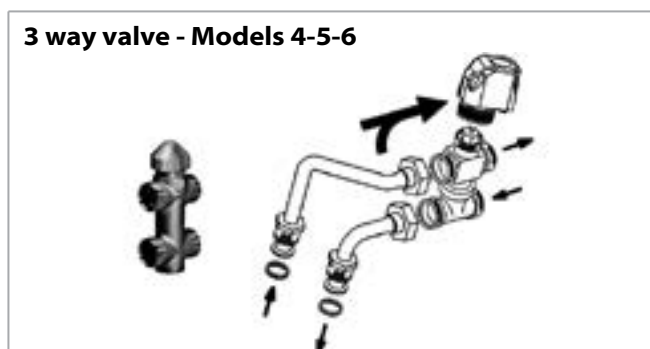
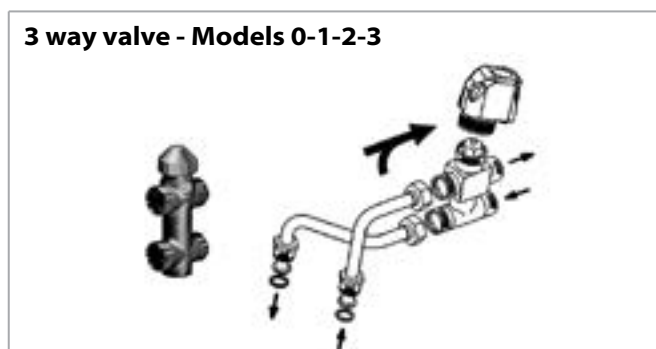

### 3 ways valves + simplified connction kit - ARMONIA ARMONIA-ECM 7-8

Model	Coil	Valve connection ø (male)	Kvs m <sup>3</sup> /h	Dp max kPa*
720 820	main	1"	4,5	50
760 860	main	1"	4,5	50
	secondary	3/4"	2,5	50

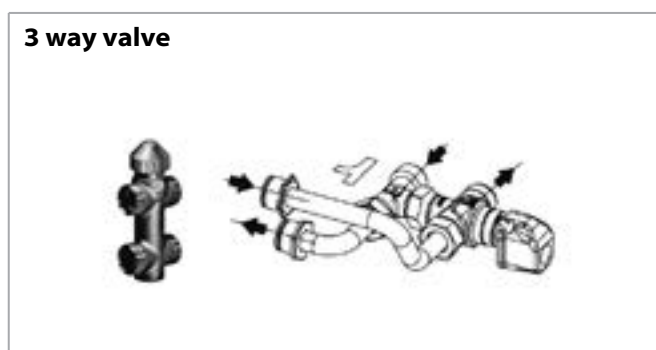

For technical data, operation limits and valves pressure drop, see p. 59

## 2 ways ON-OFF valves with actuator, without interception valve

Valve kit with 2 ways ON-OFF valves and with thermoelectric actuator; the kit includes connection pipes.

### 2 ways valves + simplified connection kit - ARMONIA ARMONIA and ARMONIA ARMONIA-ECM

Model	Coil	Valve connection ø (male)	Kvs m <sup>3</sup> /h	Dp max kPa*
020 120 220 320	main	3/4"	2,8	50
420 520 620	main	1"	4,5	60
040 140 240 260 340 360	main	3/4"	2,8	50
	secondary	3/4"	2,8	50
440 540 560 640 660	main	1"	4,5	60
	secondary	3/4"	2,8	50

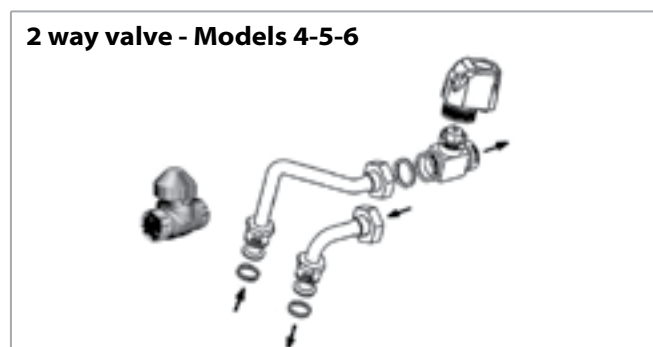
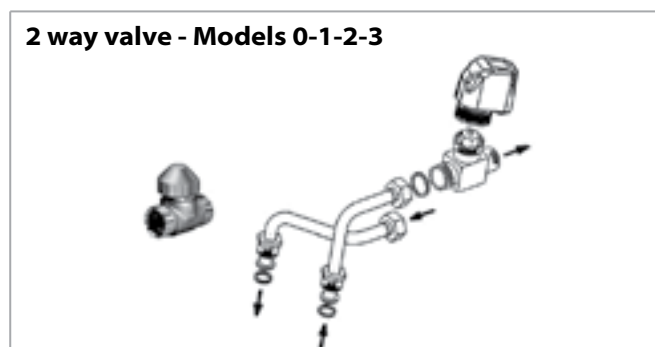

### 2 ways valves + simplified connection kit - ARMONIA ARMONIA-ECM 7-8

Model	Coil	Valve connection ø (male)	Kvs m <sup>3</sup> /h	Dp max kPa*
720 820	main	1"	4,5	60
760 860	main	1"	4,5	60
	secondary	3/4"	2,8	50

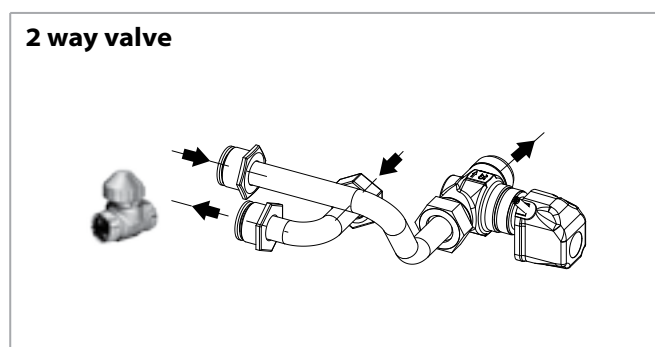

For technical data, operation limits and valves pressure drop, see p. 59

## Valves technical data and operation limits

Description	UoM	Value
Max. working pressure	bars	16
Max. ambient temperature	°C	50
Max. water temperature	°C	110
Power supply	V-Hz	230-50/60
Rating	VA	2,5
Protection		IP 44
Travel time	min	ca. 3
Max. glycol content of water	%	50

Note: The maximum pressure drop across the fully open valve should not exceed 25 kPa for cooling operation and 15 kPa for heating operation.

## Valves pressure drop

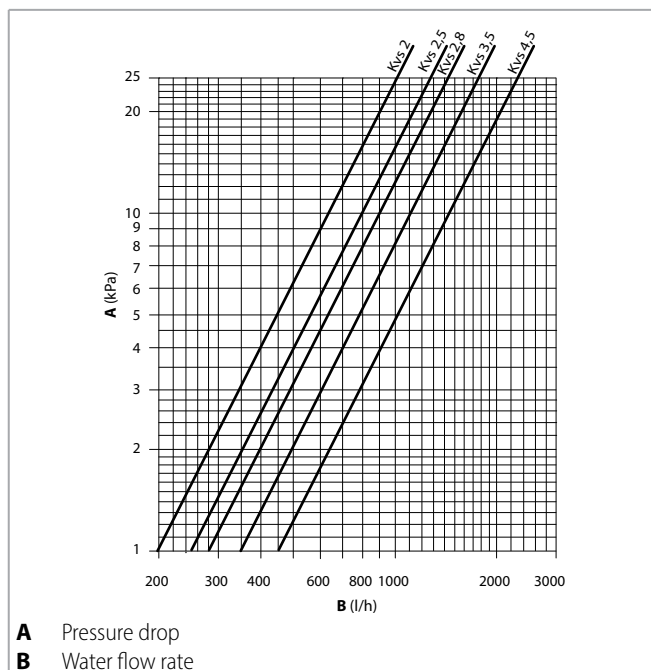

**Balance valve with actuator**

ARMONIA ECM 7-8 excluded.

**Balancing valves independent from the system pressure.**

- The balancing valve and a combined 2 way valve allow the regulation of the water flow value autonomously, regardless of the system pressure, and the control of the flow by using an ON/OFF electro-thermal actuator.
- The balancing valve allows you to balance the hydraulic system by supplying the required water flow, for each fan-coil, and to maintain it even under partial load conditions.
- A graduated ring nut allows you to set the flow rate value and also allows direct reading of the set value.

**Valve operation logic**

- "p1" the valve inlet pressure.
- "p3" the outlet pressure.
- "p2" the diaphragm activation pressure, which allows differential pressure "p2" – "p3" to be maintained at a constant value, in order to guarantee the water to flow at the set value.

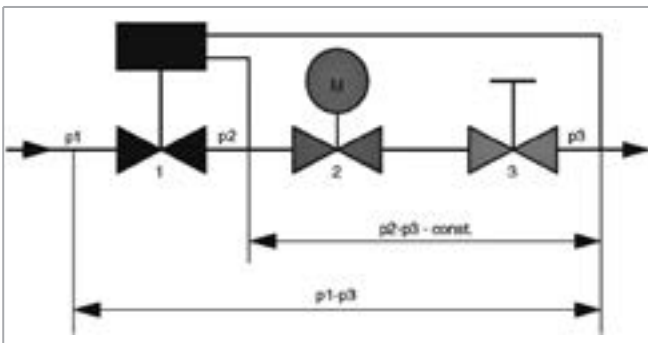

The minimum differential pressure "p1" – "p3", required to guarantee the correct value of the set water flow rate, is indicated in the diagrams and in the related tables. This is an essential factor to size the system pressure drop and pump pressure head. The flow rate is kept at a constant value only if the valve pressure drop is higher than the indicated value.

**Minimum operating differential pressure**

The minimum differential pressure and the balancing valve pressure drop must be considered to size the system pumps. Flow rate is constant if the pressure drop is higher than that indicated in the diagrams and into the related tables. The following diagram shows an example of the flow rate trend according to the pressure drop and calibration required.

**Example**

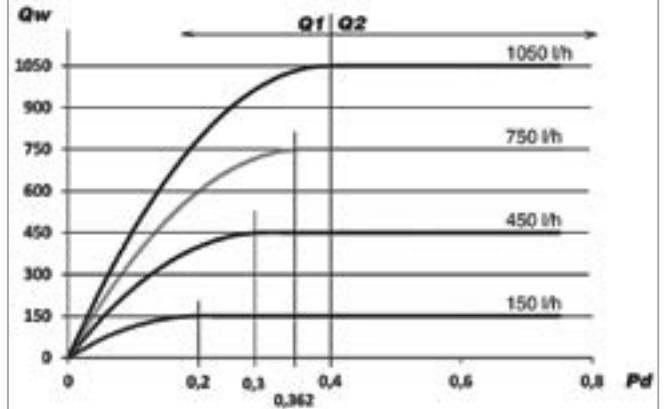

Qw = Water flow rate  
 Pd = Min. differential pressure "p1" - "p3" (bar)  
 Q1 = Area with inconstant water flow  
 Q2 = Area with constant water flow

### Kit with DANFOSS valve

ARMONIA ECM 7-8 excluded.

The flow rate can be calculated without any special tools. In order to modify the presetting (the factory value is 100%), go ahead as follow:

1. Remove the blue protective cover or the actuator fitted on the unit
2. Lift up the indicator (DN 25-32)
3. Turn (clockwise to decrease) on the new value
4. Set off the grey indicator again into the closed position (DN 25-32)

The presetting range shows flow rate values between 10-0 (DN 15-20). The clockwise rotation reduces the requested flow rate value whereas the counterclockwise rotation increases it.



### DANFOSS technical characteristics

Nominal diameter	DN	15	15HF	20HF
Flow rate range	l/h	650	1200	1900
Adjustment range	%	10-100		
Differential pressure	Dp min.	16	25	25
	Dp max.	600		
Nominal pressure	PN	25		

### Operation limits of the DANFOSS balancing valves

- Maximum operating temperature: 120 °C
- Maximum % of water/glycol mixture: 50%
- Minimum operating temperature: -10 °C

### Balancing valves for DANFOSS main coil

The valve is supplied equipped with 230 Volt electro-thermal actuator for the ON/OFF control.

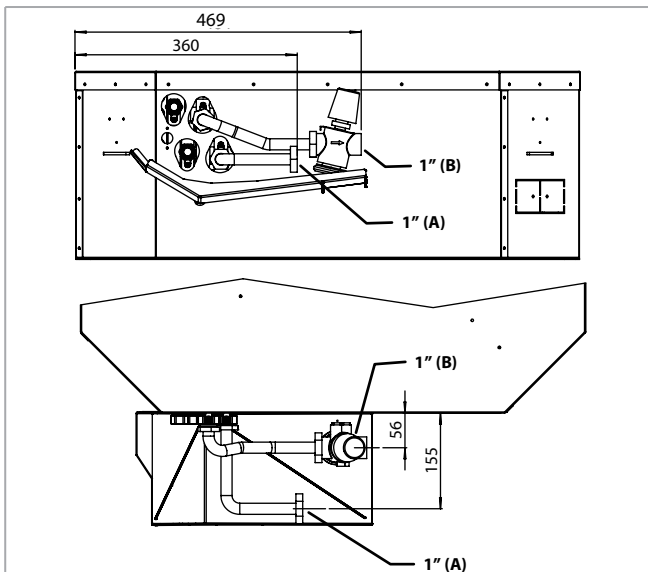
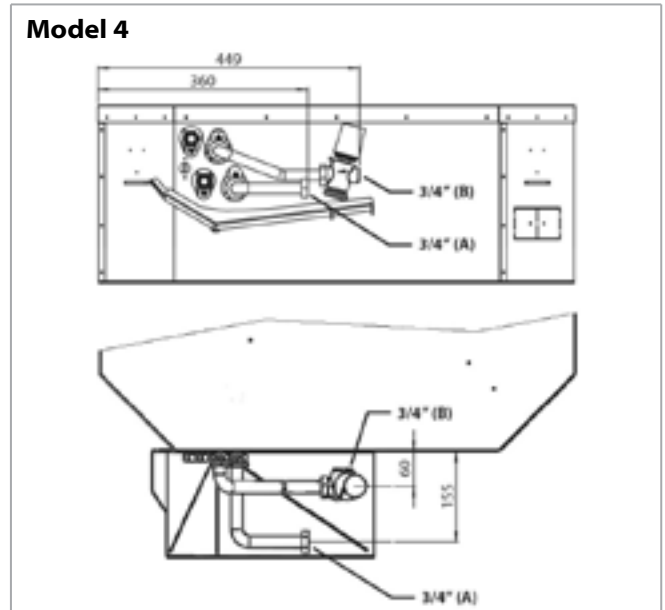
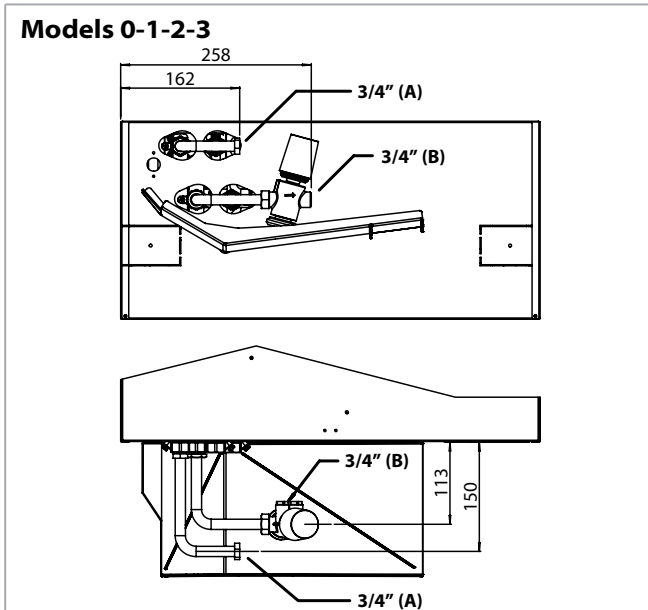

(A) = Water inlet - Female connection  
(B) = Water outlet - Male connection

Model	DN	Ø	Range	Fitted	
				Code	Code
0-3	15	3/4"	150-1050	9079774	9079784
4	15	3/4"	150-1050	9079775	9079785
5-6	20	1"	190-1300	9079776	9079786

## Balancing valves for DANFOSS main and additional coil

2 way valve for main and additional coil and assembly kit.

The valve is supplied equipped with 230 Volt electro-thermal actuator for the ON/OFF control.

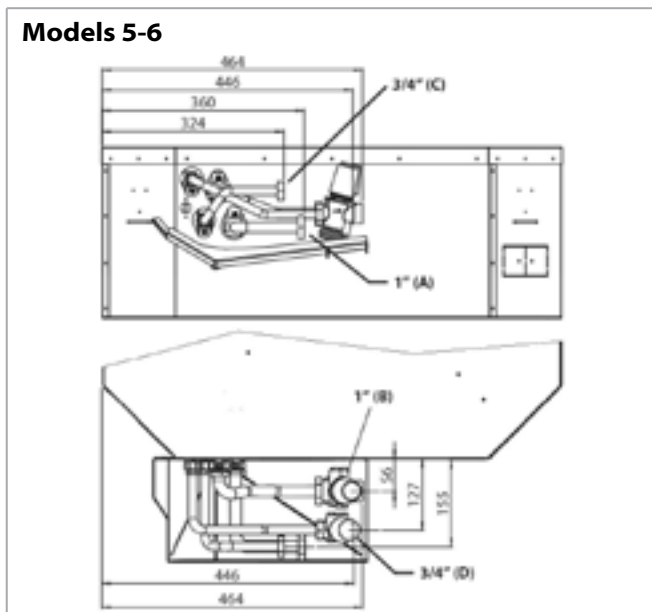
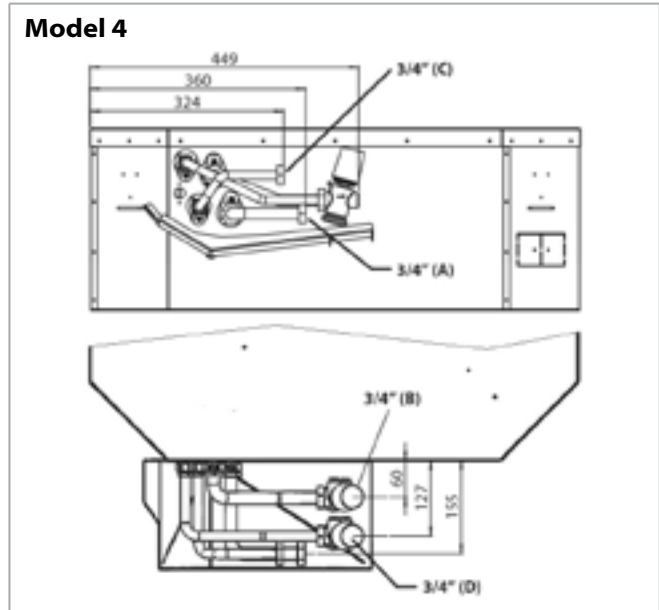
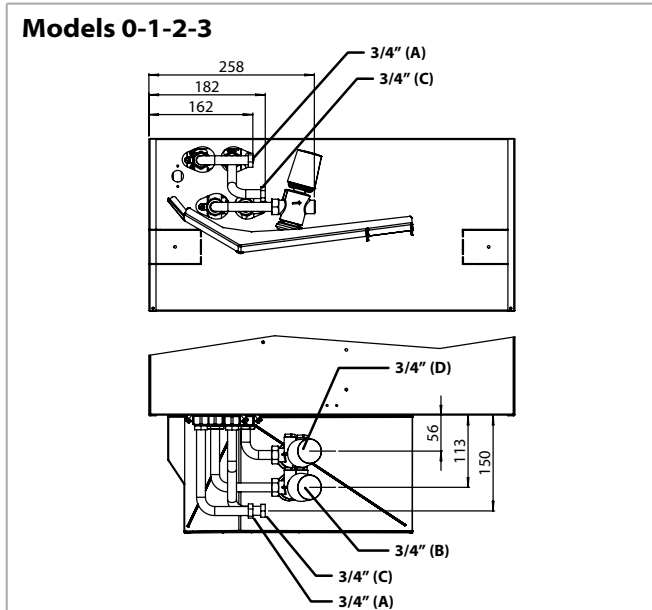

- (A) = Water inlet (main coil) - Female connection
- (B) = Water outlet (main coil) - Male connection
- (C) = Water inlet (additional coil) - Female connection
- (D) = Water outlet (additional coil) - Male connection

Model	DN	(Ø)	Range	Fitted	Not mounted
				Code	Code
0-3	15	3/4"	150-1050	9079774	9079784
4	15	3/4"	150-1050	9079775	9079785
5-6	20	1"	190-1300	9079776	9079786

Model	DN	(Ø)	Range	Fitted	Not mounted
				Code	Code
0-3	15	3/4"	150-1050	9079777	9079787
4-6	15	3/4"	150-1050	9079778	9079788

### MCT casing

Model	ID	Code
0-1-2-3	MCT 600	9079240
4-5-6	MCT 800	9079250
7-8	MCT 900	9079886

The MCT version has been designed for all environments where false ceilings are not featured or cannot be constructed.

The casing fits perfectly to the air intake and outlet diffuser, maintaining the appealing design that defines the ARMONIA series.

The water fittings can be turned to point upwards.

The MCT series includes 9 models, with an installation height of up to 5 m, thanks to the highly flexible adjustment of the air distribution louvers.

All the technical specifications described on the previous pages remain the same, while keeping in mind that:

- the MCT series features one coil only (2 pipe systems)
- there is no possibility of fresh air intake
- there is no possibility of additional electric heater

The MCT version features a special casing, in COOL GREY 1C colour, delivered in separate packaging; this must only be fitted after having installed the ARMONIA unit and completed the water and electrical connections.

Warning: the electrical and water connections must enter the unit from above and must not interfere with the casing.



### Dimension and weight

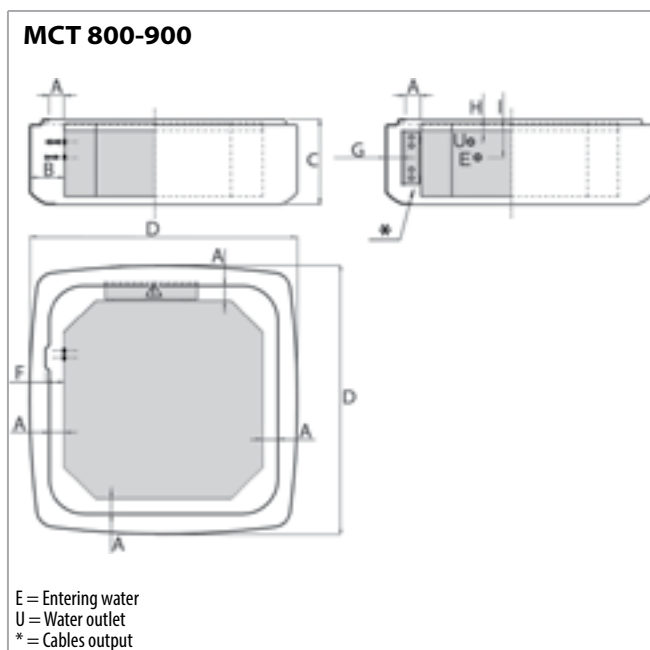
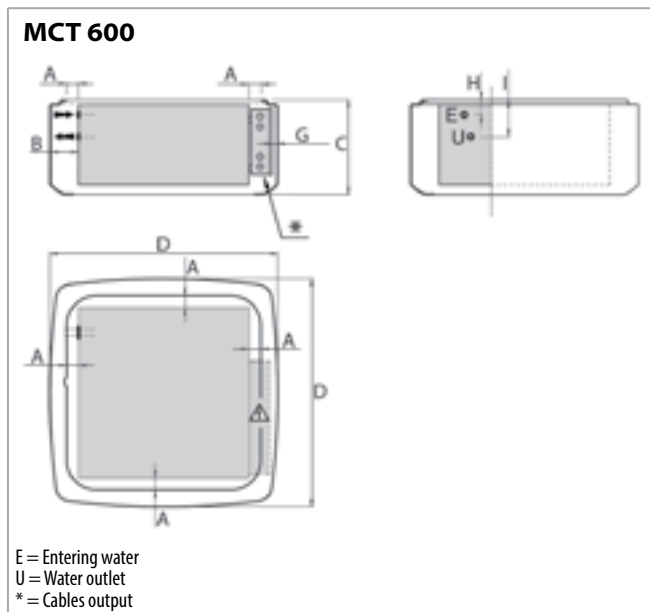

Model		MCT 600	MCT 800	MCT 900
A	mm	40	62	53
B	mm	93	140	126
C	mm	320	350	350
D	mm	768	1089	1125
F	mm	-	78	69
G	mm	15 max	65 max	33 max
H	mm	51	94	94
I	mm	125	158	158
Weight with packaging	kg	5	10,5	11
Weight without packaging	kg	7,5	13,5	14

**Assembly diagram**



**Components of the casing**

The casing includes the following elements:

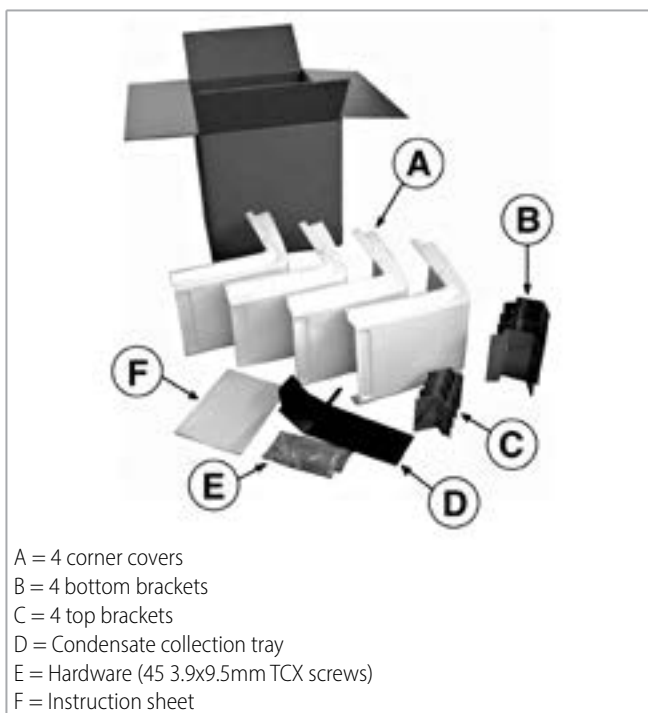

**Valves kit**

Model	Code	Kvs m <sup>3</sup> /h	Dp max kPa *	Micrometric lockshield valve connections (female)	Ball valve connections (female)
				∅	∅
MCT 600	9079155	2,5	50	3/4"	-
MCT 800	9079221	4,5		3/4"	-
MCT 900	9079945W			3/4"	1"

\* maximum pressure difference for valve to close

The valve fittings allow the water pipes to be connected from above.

