

# APPLICATION GUIDE

## AIRCOOLAIR

### ASC/ASH + CIC/CIH

Large ducted split  
19 → 134 kW

### ASC/ASH

Air cooled condensing unit  
20 → 230 kW



AIRCOOLAIR-AGU-1603-E



# AIRCOOLAIR APPLICATION GUIDE

Ref : AIRCOOLAIR- AGU-1603-E

<b>1. GENERAL DESCRIPTION</b>	<b>2</b>
<b>2. OPTIONS</b>	<b>7</b>
<b>3. GENERAL DATA</b>	<b>13</b>
<b>4. VENTILATION DATA</b>	<b>16</b>
<b>5. PERFORMANCES</b>	
Cooling and heating capacities	<b>22</b>
Auxiliary heaters selection	<b>44</b>
<b>6. ACOUSTIC DATA</b>	<b>45</b>
<b>7. ELECTRICAL DATA</b>	<b>49</b>
<b>8. DIMENSIONAL DATA</b>	<b>54</b>
<b>9. WEIGHTS DATA</b>	<b>58</b>
<b>10. REFRIGERANT CONNECTIONS</b>	<b>59</b>



Product designed and manufactured under a quality management system certified ISO 9001.



Our company's products comply with European standards.

All the technical and technological information contained in this manual, including any drawing and technical descriptions provided by us, remain the property of Lennox and must not be utilised (except in operation of this product), reproduced, issued to or made available to third parties without the prior written agreement of Lennox.

AIRCOOLAIR		20S → 140D	200D & 230D
Split	ASC/ASH + CIC/CIH	A	NA
Condensing unit	ASC/ASH	A	

**OUTDOOR UNIT**

ASC / ASH	020S	025S	030S	035S	040S	045D	055D	070D	085D	100D	120D	140D	200D	230D
Box	A	B				C			D		E			

**A BOX**



**B BOX**



**C BOX**



**D BOX**

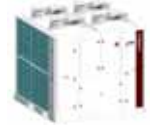

**INDOOR UNIT**

CIC / CIH	020S	025S	030S	035S	040S	045D	055D	070D	085D	100D	120D	140D
Box	A			B			C			D		

**A BOX**

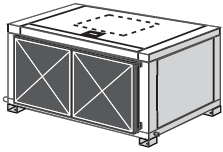

**B BOX**



**C BOX**

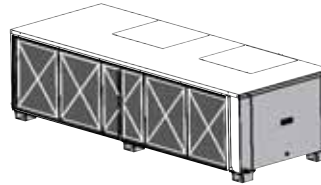

**D BOX**

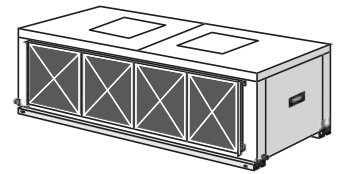

**MODEL NUMBER DESCRIPTION**

**EXAMPLE : ASC 020S NM3M + CIC 020S NM3M**

OUTDOOR UNIT	
<b>A</b>	AIRCOOLAIR
<b>S</b>	Single split
<b>C</b>	C = Cooling only H = Heat pump

INDOOR UNIT	
<b>C</b>	Common to AIRCOOLAIR and COMPACTAIR ranges
<b>I</b>	Indoor unit
<b>C</b>	C = Cooling only H = Heat pump

COMMON TO AIRCOOLAIR AND COMPACTAIR RANGES	
<b>020</b>	Cooling capacity in kW
<b>S</b>	S = 1 circuit D = 2 circuits
<b>N</b>	Not used
<b>M</b>	R410A
<b>3</b>	Revision number
<b>M</b>	400 V / 3 / 50 Hz

## INTRODUCTION

AIRCOOLAIR range is developed from ECOLEAN liquid chiller range and exists in two versions:

- **AIRCOOLAIR SPLIT UNIT**  
it can be used for medium to large commercial cooling and heating applications when the premises are not directly accessible from the roof. AIRCOOLAIR split unit exist in cooling only and heat pump versions.
- **AIRCOOLAIR CONDENSING UNIT**  
It is the outdoor unit without the supply section. This unit is available as cooling only or as heat pump and can be combined with air handling units. It provides you with a low noise level, high efficiency and almost customized units.

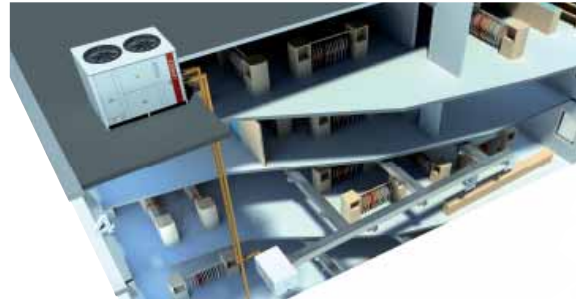

## OUTDOOR SECTION

### ASC & ASH

#### Casing

- Casing made of galvanized steel sheet metal painted with a white RAL 9002 powdered polyester paint and a RAL3003 red stripe.
- Rigid, hot dipped galvanized chassis.
- Unit lifting and handling via the base frame.
- State of the art design with hidden compressors, fans and pump for perfect architectural integration.
- Side grilles as option to protect the unit during transportation and against human aggressions.

#### High efficiency multiscroll technology

- Exclusive Compliant Scroll® design with both axial and radial compliance to increase compressor operation tolerance to liquid refrigerant, substantially improving durability and reliability.
- Motor cooled by suction gas.
- Motor protection device against high temperature or over current situations.
- Discharge non-return valve.
- Crankcase heater as standard on heat pump and optional with winter operation down 0°C for cooling only units.
- Direct on line start.
- Low noise scroll compressors insulated with a compressor acoustic jacket.
- Compressors mounted on high efficiency cellular polyurethane vibration absorbers.

#### Advanced condenser fan design

Fan-motor assembly using external rotor technology associated with OWLET high performance aluminum fan blades of the latest fan technology to improve energy consumption and airflow rate on the outdoor coils while reducing sound power level. Axial fans speed are 700 or 900 rpm according to models, direct coupling, with available static pressure up to 75 Pa as standard.

Pressure version for size 100 to 230 : speed axial fans are 1450 RPM, direct coupling, with available static pressure up to 250 Pa. For small sizes, COMPACTAIR is the appropriate unit for technical room.

#### Heat exchanger

Made of copper tubes and aluminum corrugated swirl fins, the coil heat exchanger are designed to maximize the output.

#### Refrigerant circuit:

AIRCOOLAIR outdoor units operate with R410A refrigerant. For cooling only outdoor units, each circuit includes in standard:

- High pressure switch with automatic reset.
- Low and high pressure transducers.

On heat pumps outdoor units, each circuit includes in addition, as standard :

- Four-way valve
- Liquid receiver
- Thermostatic expansion valve
- Filter drier

Each refrigerant circuit is pressure and leak tested with a Hydrogen/Nitrogen mixture, and vacuumed before being charged with nitrogen. All units are then subjected to a complete functional and operational run test to guarantee perfect sealing before leaving the factory.

#### Electrical box:

- Unit wiring in compliance with standard EN 60204-1.
- IP54 water protection.
- Circuit breaker protection for compressors and fans.
- Compressor and fan working contactors.
- Terminal block and wiring for power supply to the unit.
- Power supply 400V/3/50Hz without neutral except for size 20S with neutral.

**INDOOR SECTION  
CIC & CIH**

**Casing**

Casing made of galvanized steel sheet metal painted with a white RAL 9002 powdered polyester paint.

**Fan**

Indoor sections are supplied with one or two double-inlet centrifugal fans. Double fans are fitted with a common axle with one motor. Equipped with adjustable drive, variable pulley and belt, to set up the right airflow on site.

**Air filter**

G4 washable air filter; auto extinguishable material with M1 classification.

**Heat exchanger**

Made of copper tubes and aluminum corrugated swirl fins.

**Refrigerant circuit:**

On cooling only and heat pumps indoor units, each circuit includes as standard :

- Thermostatic expansion valve
- Filter drier

Each refrigerant circuit is pressure and leak tested with a Hydrogen/Nitrogen mixture, and vacuumed before being charged with nitrogen. All units are then subjected to a complete functional and operational run test to guarantee perfect sealing before leaving the factory.

**ENERGY SAVINGS**

**R410A refrigerant**

Efficient systems such as AIRCOOLAIR are designed around R410A refrigerant to achieve the best performances.

- Energy efficient refrigerant thanks with pressure drop in the pipes: Higher evaporating pressure and lower condensing pressure improve compressor EER & COP.
- R410A compressors have a better isentropic efficiency.
- Environmentally friendly refrigerant: It contains No Chlorine (ODP = 0).

auxiliary heating during defrost cycles. With Alternate defrost when one circuit starts a defrost cycle the other circuit is running in heat pump at full capacity to minimize the need for auxiliary heating.

**Free cooling: economizer for Split Unit**

Indoor sections are supplied with one or two double-inlet centrifugal fans. Double fans are fitted with a common axle with one motor. Equipped with adjustable drive, variable pulley and belt, to set up the right airflow on site.

**Morning anticipation and dynamic set point for Split Unit :**

The unit can be programmed to switch-on in the morning to reach the occupied zone temperature set point just in time. Dynamic set point can be used in summer to offset the ambient temperature set point according to the outdoor temperature. This is to avoid large temperature difference between indoor and outdoor. The indoor temperature set point would then increase with the outdoor temperature improving comfort and saving large amount of energy

**Dynamic and alternate defrost**

Defrost is necessary to ensure efficient operation of heat pumps in winter. The unit starts defrost cycle when the outside temperature is below a set temperature and repeat the defrost cycles periodically. It results sometimes in starting an expensive defrost cycle when it is very cold outside but very dry, or too warm, in other words when the coil is not frozen.

- Dynamic defrost is Lennox' answers to unnecessary defrost cycles. Dynamic defrost detects icing of the coil by monitoring the difference between refrigerant and outside temperature and starts the defrost cycle only when required. Under certain conditions a rooftop unit equipped with this built in dynamic defrost feature can run several hours in heat pump mode without starting any defrost cycle. Dynamic defrost can save up to 15% on annual energy consumption.
- Alternate defrost saves energy by reducing the need for

**Scheduling / Time zone Management:**

In order to ensure the unit perfectly matches the requirements of the most difficult applications in terms of occupation and varying internal loads, the CLIMATIC 60 offers now up to 7 time zones per day (Z0 to Z6) adjustable by steps of 10 minutes. Each time zone can be programmed to follow one of four possible operating modes: A,B,C & D

## CONTROL

The new generation of microprocessor based control, CLIMATIC 60 equip the AIRCOOLAIR range.

It inherits more than 20 years of technology and field operating experience from its predecessors Climatic control platforms. CLIMATIC 60 controller intelligently improves efficiency and helps set up and service operations to guarantee long lasting performance.

CLIMATIC 60 is designed to provide the best energy efficiency throughout unit's life cycle while ensuring reliable and consistent operation with user friendly interfaces.

This new controller constantly monitors more machine parameters than ever to improve unit operation and maximize efficiency and reliability

The PI algorithm of the CLIMATIC 60 controls the supply air temperature and a temperature difference between supply and return. It is able to optimize the refrigeration circuit operation to match perfectly the required cooling or heating load maximizing efficiency and comfort.

It will also improve reliability with features such as compressor operating limits monitoring, (High and Low refrigerant pressure and temperature now measured and displayed on DS60 and Bus) refrigerant leak detection or compressor operating time equalization and protection against excessive short cycling.

### **Faults and alarms**

CLIMATIC 60 manages more than 90 different faults and alarms codes and can store the last 32 with time and date. The stored faults and alarms can then be displayed on the DS60 and on the communication bus with the full text detail.

## COMFORT AND AIR QUALITY OF SPLIT UNIT

### **Intelligent air quality management**

With accurate percentage of fresh air the dampers are regularly calibrated to introduce just the required amount of fresh air in the building to reduce annual energy consumption. The fresh air ratio can also be controlled using the indoor CO2 level as an input.

### **Intelligent heating priority optimization**

This feature allows the user to program the priority between the different heating elements (thermodynamic, electric heaters or auxiliary heating). This is particularly interesting on units with electrical pre-heaters. This feature maximizes energy efficiency by optimizing heat pump operation depending on the outdoor temperature.

### **Filtration**

Two filtration levels are available. The standard equipment is G4 washable and refillable filters with metallic frame. This type of configuration allows to extend the lifecycle of filters and reduce the cost of replacement, changing only the media. G4 pre-filter/ F7 filter is optional.

### **Fire Insulation**

Air treatment sections are insulated with M1 material: this insures that the insulation doesn't burn and doesn't create toxic smoke. M0 insulation is in option mechanically fitted.

## PLUG AND PLAY UNIT

### Power supply

To make installation easier, AIRCOOLAIR power supply does not require «neutral» connection. It is powered by 400 V, 3 phases, 50 Hz except size 20S

### Circuit breakers

To improve the safety of the AIRCOOLAIR and extend its life, circuit breakers protect against over-loading, over intensity and a disconnected supply phase. Maintenance is also improved as there is no requirement to change fuses. The electrical panel is manufactured in accordance with EN60204-1 (1998) electrical directive.

### Adjustable ventilation for Split Unit

Airflow and external static pressure characteristics are adjusted in the factory to deliver the right pulley and belt to be the nearest to the site needs. However, once on site, the real characteristics of ventilation requirement might be slightly different than theory measured on drawings: therefore, AIRCOOLAIR Split unit is delivered as standard with adjustable pulley opened. This remains the possibility to adjust the airflow accurately at the commissioning and find the perfect airflow for the site comfort and system efficiency.

### Refrigerant pressure reading :

No need to access to refrigerant pressure gauges. Refrigerant pressures and superheat on each circuit can be read directly on the service display DS60 or a BMS as all units are equipped with high and low pressure transducers and refrigerant suction temperature probes

### Easy access

All access to internal components of the AIRCOOLAIR units are closed by panels equipped by locks and handle for quick and easy dismounting. No more screws are used as panel fixtures.

## EXTENDED LIFECYCLE

Assembly quality, compliance to PED 97-23, EN 60204-1, CE, made in an ISO 9001v2000 factory.

What makes the difference are the small details which have given LENNOX its reputation. Electrical components are selected to the highest standards, refrigeration components are generously sized to ensure maximum performance and reliability. Quality manufacturing procedures together with a culture of continuous improvement at all LENNOX factories, ensures the products are built to the highest standards.

AIRCOOLAIR complies to EN60204 norms, PED 97-23 directive, is CE compliant and is built in an ISO9001v2000 certified Factory



## FRESH AIR OPTIONS

### Economizer



**020S - 045D**



**055D - 140D**

Free cooling is provided through the use of fresh air when it's appropriate rather than cooling the return air. Using an economizer is the easiest and most efficient way to modulate fresh volumes and reduce running costs for air conditioning application, as well as improving air quality. Fully controlled by the CLIMATIC, it is also able to ensure that minimum fresh air is provided in line with Indoor Air Quality Regulations. Economizer operates using a «sensible» control. It is possible to prevent the economizer from supplying air below a certain temperature (adjustable set point, 10°C as default).

**On sizes 20S to 45D**, the economizer is factory fitted on unit and tested prior to shipment. It includes 2 dampers operating from a 24V actuator.

**On sizes 55D to 140D**, the economizer is delivered as a separate module that can be installed as monobloc on site. It includes 3 dampers operating from 3x 24V actuators

### Exhaust module

The exhaust fans eliminate the air overpressure in the room. It



**020S - 045D**



**055D - 140D**

is driven by the Climatic controller.

**On sizes 20S to 45D**, it is delivered as a separate module that can be connected to the return duct.

**On sizes 55D to 140D**, this exhaust fan is in built in the economizer casing

### Return Module



The RETURN FAN module is necessary when the return duct circuit creates high pressure drops. It offers available static pressure up to 250-300 Pa. It includes a separate casing to be connected to the economizer casing with the ductworks. The return module drives the opening and closure of the 3 dampers regarding the amount of fresh air introduced.

### eDrive: available in Non Standard Request

eDrive, direct transmission on return fan and supply fan : variable speed fans adjust airflow rate to the exact needs and during unoccupied period. This feature saves up to 30% annual energy consumption and reduces maintenance costs. CLIMATIC manages air flow rate passing through the unit following 3 possible strategies. eDrive control strategies can be changed with each time zone in occupied or unoccupied mode. Whatever the control strategy, soft starter is still available to inflate flexible ducts and reduce inrush current during fan starts.

- Standard mode : Constant air flow rate
- Dead Zone mode : Reduced air flow rate in "dead zone".
- Part Load mode : Variable air flow rate during part load and dead zone.

## INDOOR AIR QUALITY OPTIONS

### High filtration level - G4 pre-filter / F7 filtration

G4 pre-filter 50 mm / F7 filter 100 mm are both in metallic refillable frames. This configuration allows extending the lifecycle of filters and reducing the cost of replacement, changing only the media. 100 mm filters have been selected also to reduce the energy consumption due to:

- lower pressure drop especially when the filters start being dirty.
- decrease of the replacement frequency.

### Analog dirty filter and fan control :

This analog pressure sensor analyses the clogging of the filters to inform the user and to allow preventive replacement of the filters that will decrease the energy consumption and increase the air quality.

### Air Quality sensor :

This function allows to adapt the minimum fresh air to the building occupancy. It measures the CO<sub>2</sub> level and adjust the fresh air volume accordingly.

Indoor air quality is controlled from the CLIMATIC main controller. A VOC (Volatile Organic Component) sensor detects the amount of CO<sub>2</sub> in the ambient air between 0 and 2000PPM. The VOC sensor sends a proportional signal (0-20mA) to the CLIMATIC controller which will then modulate the fresh air damper.

## AUXILIARY HEATERS OPTIONS

### Stepped or modulating Electrical heaters

Additional or instead of heat pumps, Lennox offers many auxiliary heaters on every air-to-air units. This helps to adapt to local climate requirement, local regulation preferences and applications variable heating needs.

Standard, Medium and High heating power capacity are available on each unit size

High electrical heater is also available as modulating instead of 2-stage heater.

The performances of this option are available in auxiliary heaters selection: page 44

The electric heater comprises of shielded resistance heaters, which are smooth anticorrosion tubes 8 W/cm<sup>2</sup> capacity.

3 security elements are insuring permanent controls of the heaters:

- 2 high temperature limit controls offer overload protection. An automatic reset safety thermostat is set at 75°C – a manual reset safety thermostat is set at 105 °C; both located at less than 150 mm over electric heaters. This is provided as a standard feature on the electric heater, with the electric power supply cables made of reticulated silicon rubber, resistant to temperatures up to 200°C.
- an air pressure differential controls the fan activity and disconnects the electrical heater in case of critical airflow
- dual contactor are insuring safe redundancy in case of failure of one dry contact

### Modulating Hot water coil :

This modulating heater is equipped with a 3 way valve offering accurate comfort and electronic adjustable antifreeze protection. This avoids the use of glycol in most of European regions.

The hot water coils and control valves are factory fitted in air treatment section.

The performances of this option are available in auxiliary heaters selection page 44.

## REFRIGERATION OPTIONS

### Winter cooling operations down to 0 °C

This option allows the AIRCOOLAIR to operate in cooling mode with an outside temperature down to 0°C (instead of 15°C on the standard unit).

This is especially needed when free-cooling operation is not possible. This function is made of condenser fan alternate start/stop that maintains a constant condensing pressure.

This equipment is standard on heat pump versions

### Winter cooling operations down to -15 °C

Unit fitted with variable speed fans. This option also allows cooling operation in very low outside temperature (-15°C), with good performance on condenser fan, belt lifecycle extension and starting peak current reduction.

Strongly recommended for applications where cooling is required during winter.

### Refrigerant pre-charged

As standard, the units are delivered with Nitrogen. With this option, the outdoor unit is fitted with refrigerant and equipped with service valves option.

### Active Acoustic Attenuation System with variable speed fans

Low Noise option consists in an acoustic jackets

Besides, with the variable speed fan include in Winter cooling operations down to -15 °C option, the CLIMATIC 60 controls the fan speed limited by the Smart Acoustic System which allows progressive adaptation of the unit to the building load while respecting the noise level constraints and the operating limits.

The maximum sound level and the fan strategies can be adjusted according to the schedule mode in order to benefit from the different modes "Auto", "Auto Quiet" and "Quiet" operation as well as in heating or cooling mode.

The Active Acoustic Attenuation System can be adjusted according to the scheduling and can take different values for each schedule mode.

### Service valves

This option consists in liquid and gas service valves that isolate the refrigerant section during maintenance. This is particularly useful when components of the circuit have to be changed. It reduces the time and cost of maintenance operation.

### Long distance refrigerant connection

When the distance between the condensing section and the treatment section is over 40 meters of copper piping, this kit has to be installed. It allows distance up to 65 meters.

## INSTALLATION AND SAFETY OPTIONS

### Main disconnect switch

Main disconnect switch is lockable to make a safe access to electrical panel. It is installed on the electrical panel door of the compressor section and controls all parts. Is also used as emergency cut off: it is mandatory to guarantee a proper access to this switch. Main disconnect switch is sized accordingly to the options fitted in the unit.

### Smoke detector

Located downstream of the filter, the optical head of the smoke detector can detect any type of smoke. When this occurs the unit will stop operating, the return air damper will be fully closed and the fresh air damper will fully open while sending an alarm signal to the unit.

In accordance with the European norm, it is also compliant with the French regulation on public buildings.

### Compressor electrical protection

Return lock against 3 phases inversion at installation. This protection prevents the Scroll compressor from starting and operating in the wrong sense: in case of the electrical phases are wrongly connected, the compressor will not start. The compressor electrical protection option is particularly required when the installation of the air conditioning unit is made before the electrical wirings.

### Condenser coil guards:

The condenser coil protection grill prevents light damage to the coil when shipping and when installed.

### Coil Anticorrosion protection:

When the units are installed in potentially aggressive environments, which can often be the case for example in coastal environments, it is often a requirement that the coils are specially treated to protect them against the corrosive effects. LenGuard anti-corrosion treatment is available on indoor and outdoor units.

### M0 Insulation indoor unit:

Because health and safety issue cannot be compromised, Lennox equips its air treatment units (indoor unit) with a fire-proof insulation M0 that is mechanically fitted to the unit.

### Anti-vibration mounts rubber type (supplied loose)

These parts reduce the transmission of vibration to the ground and the general sound level. They are fixed under the unit at the points specified by our technical drawing.

### Pallet packaging

This unit protection option is wooden pallet packaging with plastic bag useful during potentially bad shipment condition: long distance by truck or container.

## CONTROL AND COMMUNICATIONS OPTIONS

### DC60 remote comfort display (supplied loose)

This is a remote controller for non-technical customer. It has been designed to aesthetically fit inside a room and be very easy to use. It can be installed at maximum 50 meters from the unit. There are two levels : In the first level, ambient temperature is provided and the setpoint temperature or offset to this setpoint temperature can be adjusted (according to settings and rights offered by the technician). The unit can be turned On and Off in this level. The full level additionally provides information such as outdoor temperature, supply temperature, ambient humidity level, air quality, fresh air damper opening percentage, time zone and working mode of the given time zone. DC60 Comfort display shows faults number when the unit is in the failure mode. Customer can reset fault thanks to a combination of keys. Time and day of the unit can be seen and modified easily through the DC60.

### DS60 Service display (supplied loose)

This plug and play service display and controller allows maintenance staff to set up, read and modify all unit parameters (unit settings, operating time and number of compressor starts, low and high pressure reading, airflow rate of supply fan, and read the history of last 32 faults...).

This controller has been designed to be very user-friendly, with 6 different keys and a graphic display. It includes scrolling menus and full text (no codes) explanation. It is available in English or other languages.

### DM60 Multi-units display (supplied loose)

The DM60 remote display can manage up to 8 units on a single Bus. On a multiunit site it makes the installation less expensive because, not only because of DM60 price, but because only one bus-wire has to be connected down to the DM60. In addition to the functions offered by the DC60 display, the DM60 display provides the percentage of power factor for compressors and auxiliary heater. Moreover DM60 display allows to set time zones and to modify working modes for the given time zone. These information are available for each of the units connected to the Bus. It can be installed up to 1000 meters from the unit.

### BE60 Extension control board

This board has been developed for any customer who wants to take over the control of the unit using digital or analogue input signal. With this dry contact board option the customer can set:

- 4 digital inputs (On/Off, clear faults, various component unloading, heating priority modifications, thermostat orders...)
- 4 digital Outputs (alarms reporting, components status, scheduling time zone and operating mode status, cooling, heating, defrost and auxiliary heating status...)
- Up to 4 analogue inputs (external temperature humidity probes, fresh air input signal, force fan speed and temperature setpoint offset).
- 1 analogue output (Humidifier)

Note that CLIMATIC controller always stays in charge of all safety algorithms, defrost operation and free cooling. This option is required to control the unit with a "universal thermostat".

The BE60 expansion board is an additional board fixed on DIN rail. This board is supplied as standard on AIRCOOLAIR condensing unit.

### Modbus communication interface RS485

Communication card using ModBus protocol with RS485. Communication interface with a building management system.

### BACnet® communication interface RS485

Communication card using Bacnet® protocol with RS485. Communication interface with a building management system.

### LonWorks® communication interface

Communication card using LonTalk® protocol. Communication interface with a building management system.

### Modbus or BACnet® communication interface TCP/IP

Communication card using Bacnet ® or Modbus with TCP/IP. Communication interface with building management system.

**DC60 :**  
**REMOTE COMFORT DISPLAY**



**DS60 :**  
**SERVICE DISPLAY**



**DM60 :**  
**MULTI-UNIT DISPLAY**



Legend :

STD = As standard  
 NSR = Non standard request  
 N/A = Non available

Models

	Split unit		Condensing unit	
	Cooling only	Heat pump	Cooling only	Heat pump
<b>INDOOR SECTION : CIC AND CIH</b>				
Economizer	X	X	N/A	N/A
Exhaust module	X	X	N/A	N/A
Return module	Size 55 - 140		N/A	N/A
Fresh air over - Return bottom	Size 20 - 45		N/A	N/A
Fresh air left - Exhaust right	Size 55 - 140		N/A	N/A
<b>Filtration</b>				
High filtration level G4 prefilter / F7 filtration	X	X	N/A	N/A
<b>Auxiliary heating</b>				
Electrical heater standard	X	X	N/A	N/A
Electrical heater medium	X	X	N/A	N/A
Electrical heater high	X	X	N/A	N/A
Electrical heater high - Modulating	X	X	N/A	N/A
Modulating hot water coil	X	X	N/A	N/A
<b>Control</b>				
Smoke detector	X	X	N/A	N/A
Air quality sensor	X	X	N/A	N/A
Remote duct sensor	X	X	N/A	N/A
Analog dirty filter and fan control	X	X	N/A	N/A
<b>Airflow configuration</b>				
Vertical air supply	X	X	N/A	N/A
<b>Other options</b>				
M1 insulation indoor unit	X	X	N/A	N/A

Legend :

 STD = As standard  
 NSR = Non standard request  
 N/A = Non available

Models			
Split unit		Condensing unit	
Cooling only	Heat pump	Cooling only	Heat pump

**OUTDOOR SECTION : ASC AND ASH**
**Refrigeration option**

Winter cooling operation down to 0°C outdoor temperature	X	STD	X	STD
Winter cooling operation down to -15°C outdoor temperature	X	NSR	X	N/A
Service valves	X	X	X	X
Refrigerant precharged	X	X	X	X
Long distance refrigerant connection up to 65 m	X	X	N/A	N/A

**Electrical and safety**

Main disconnect switch	X	X	X	X
Compressor electrical protection	X	X	X	X
Condenser coil guards	X	X	X	X

**Control & Communication**

Advanced control pack (enthalpy and humidity control)	X	X	N/A	N/A
Modbus communication interface RS485	X	X	X	X
Lonworks® communication interface	X	X	X	X
Bacnet® communication interface RS485	X	X	X	X
Modbus or bacnet® communication interface TCP/IP	X	X	X	X
DC60 remote comfort display (supplied loose)	X	X	X	X
DS60 service display (supplied loose)	X	X	X	X
DM60 service display (supplied loose)	X	X	X	X
BE60 expansion control board	X	X	STD	STD

**Other options**

High static pressure up to 250 Pa	Size 100 - 140		Size 100 - 230	
Low noise version	X	X	X	X
Outdoor coil anticorrosion protection	X	X	X	X
Outdoor & indoor coil anticorrosion protection	X	X	N/A	N/A
Rubber anti-vibration mounts (supplied loose)	X	X	X	X
Pallet packaging	X	X	X	X

LARGE DUCTED SPLIT		20S	25S	30S	35S	40S	
<b>Cooling mode - ASC + CIC - ASH + CIH</b>							
Gross cooling capacity <sup>(1)</sup>	kW	19,9	24,2	27,9	36,5	41,9	
Net cooling capacity <sup>(1)</sup>		19,5	23,5	27,0	35,5	40,5	
Absorbed power <sup>(1)</sup>		6,72	8,45	9,82	12,4	14,7	
Gross EER <sup>(1)</sup>		3,13	3,12	3,11	3,19	3,15	
Net EER <sup>(1)</sup>		2,90	2,78	2,75	2,86	2,75	
<b>Heating mode - ASH + CIH</b>							
Net heating capacity <sup>(1)</sup>	kW	19,5	25	28,5	36	40	
Net COP <sup>(1)</sup>		3	3	2,95	3,03	3	
Net absorbed power <sup>(1)</sup>	kW	6,5	8,33	9,66	11,9	13,3	
Electrical heater capacity		S <sup>(3)</sup>	10	10	10	15	15
		M <sup>(3)</sup>	15	15	15	20	20
		H <sup>(3)</sup>	20	20	20	27	27
Hot water coil capacity <sup>(2)</sup>		31	38	40	56	61	
<b>Refrigerant circuit</b>							
Number of compressors/Number of circuits		1/1	1/1	1/1	1/1	1/1	
Refrigerant charge per circuit (approximate)	kg	4,9	5,9	6,33	8,84	10,83	
<b>Air treatment ventilation</b>							
Minimum airflow	m <sup>3</sup> /h	3150	4250	4650	6200	6950	
Maximum airflow		4100	5500	6000	8050	9050	
Maximum available static pressure	Pa	685	672	650	729	833	
<b>Condensing unit ventilation</b>							
Nominal airflow	m <sup>3</sup> /h	6800	9750	11500	11300	11000	
<b>Acoustic data</b>							
Outdoor blower outlet sound power Standard unit (Lw) <sup>(1)</sup>	dB(A)	72	76	76	77	78	
Outdoor blower outlet sound power Low noise unit (Lw) <sup>(1)</sup>		70	71	70	71	72	
Indoor blower outlet sound power level (Lw)		75	82	82	82	85	

(1) EUROVENT conditions data

Cooling :

Outdoor temperature = 35°C DB  
 Entering coil temperature 27°C DB / 19°C WB

Heating :

Outdoor temperature = 7°C DB / 6°C WB  
 Indoor temperature = 20°C DB

(2) Air inlet temperature = 20°C  
Water temperature = 90-70°C(3) S = Standard heat  
M = Medium heat  
H = High heat



<b>LARGE DUCTED SPLIT</b>		45D	55D	70D	85D	100D	120D	140D	
<b>Cooling mode - ASC + CIC - ASH + CIH</b>									
Gross cooling capacity <sup>(1)</sup>	kW	48,7	57,3	72,4	86,0	103,9	116,2	140,6	
Net cooling capacity <sup>(1)</sup>		46,5	55,5	69,5	82,0	100,0	111,0	135,0	
Absorbed power <sup>(1)</sup>		17	19,8	24,8	29,8	35,7	38,9	48,2	
Gross EER <sup>(1)</sup>		3,28	3,17	3,3	3,33	3,26	3,44	3,3	
Net EER <sup>(1)</sup>		2,73	2,8	2,8	2,75	2,8	2,85	2,80	
<b>Heating mode - ASH + CIH</b>									
Net heating capacity <sup>(1)</sup>	kW	49,5	56,5	72,5	80	108	118	137	
Net COP <sup>(1)</sup>		2,9	3	3	3	3,13	3,05	2,82	
Net absorbed power <sup>(1)</sup>	kW	17,1	18,8	24,2	26,7	34,5	38,7	48,6	
Electrical heater capacity		S <sup>(3)</sup>	15	20	20	20	27	27	27
		M <sup>(3)</sup>	20	27	27	27	40	40	40
		H <sup>(3)</sup>	27	40	40	40	50	50	50
Hot water coil capacity <sup>(1)</sup>		66	91	105	113	171	183	192	
<b>Refrigerant circuit</b>									
Number of compressors/Number of circuits		2/2	2/2	2/2	2/2	3/2	3/2	3/2	
Refrigerant charge per circuit (approximate)	kg	6,94 + 6,94	6,42 + 6,42	8,74+ 8,74	10,9 + 10,9	13,98 + 11,6	17,32 + 11,16	17,23 + 17,1	
<b>Air treatment ventilation</b>									
Minimum airflow	m <sup>3</sup> /h	7950	9950	12450	14000	17350	19300	21000	
Maximum airflow		9750	12850	15090	16725	22450	24950	24750	
Maximum available static pressure	Pa	812	747	711	680	812	784	828	
<b>Condensing unit ventilation</b>									
Nominal airflow	m <sup>3</sup> /h	2 x 9750	2 x 11500	2 x 11300	2 x 11000	22700 + 18100	22700 +18100	2 x 22700	
<b>Acoustic data</b>									
Outdoor blower outlet sound power Standard unit (Lw) <sup>(1)</sup>	dB(A)	79	79	80	81	82	83	87	
Outdoor blower outlet sound power Low noise unit (Lw) <sup>(1)</sup>		74	73	74	75	76	76	81	
Indoor blower outlet sound power level (Lw)		86	80	85	87	85	87	89	

(1) EUROVENT conditions data

**Cooling :**

Outdoor temperature = 35°C DB  
Entering coil temperature 27°C DB / 19°C WB

**Heating :**

Outdoor temperature = 7°C DB / 6°C WB  
Indoor temperature = 20°C DB

(2) Air inlet temperature = 20°C

Water temperature = 90-70°C

(3) S = Standard heat

M = Medium heat

H = High heat



CONDENSING UNIT		020S	025S	030S	035S	040S	045D	055D
<b>Cooling mode - ASC</b>								
Cooling capacity <sup>(1)</sup>	kW	19,7	24,7	28,4	36,1	42	49,4	56,7
EER <sup>(1)</sup>		3,06	3,05	2,95	3,03	2,98	3,05	2,94
<b>Heating mode - ASH</b>								
Heating capacity <sup>(2)</sup>	kW	19,8	25,0	28,6	36,0	40,2	50,1	57,1
COP <sup>(2)</sup>		3,20	3,21	3,12	3,24	2,98	3,21	3,1
<b>Refrigerant circuit</b>								
Number of compressors/Number of circuits		1/1	1/1	1/1	1/1	1/1	2/2	2/2
Capacity steps		1	1	1	1	1	2	2
<b>Electrical data</b>								
Voltage		400V/3 Ph/50Hz						
Maximum absorbed power	kW	8,55	10,8	12,5	16,4	17,7	21,6	25
<b>Acoustic data</b>								
Sound power level <sup>(3)</sup>	dB(A)	76	78	81	80	81	81	84
CONDENSING UNIT		070D	085D	100D	120D	140D	200D	230D
<b>Cooling mode - ASC</b>								
Cooling capacity <sup>(1)</sup>	kW	72,1	83,9	104	115	141	197	228
EER <sup>(1)</sup>		3,04	2,96	3,03	3,1	3,05	3,11	3,06
<b>Heating mode - ASH</b>								
Heating capacity <sup>(2)</sup>	kW	71,9	80,3	105	114	137	191	218
COP <sup>(2)</sup>		3,24	3,1	3,24	3,2	3,13	3,19	3,06
<b>Refrigerant circuit</b>								
Number of compressors/Number of circuits		2/2	2/2	3/2	3/2	3/2	4/2	4/2
Capacity steps		2	2	2	2	2	2	2
<b>Electrical data</b>								
Voltage		400V/3 Ph/50Hz						
Maximum absorbed power	kW	32,8	35,5	45,6	48,7	59,9	83,0	96,2
<b>Acoustic data</b>								
Sound power level <sup>(3)</sup>	dB(A)	83	84	87	87	90	89	82

(1) Evaporating temperature = 7°C / Ambient temperature = 35°C

(2) Condensing temperature = 50°C / Ambient temperature = 7°C DB/6°C WB

(3) EUROVENT conditions data

**TREATMENT VENTILATION DATA  
LARGE DUCTED SPLIT**

CIC/CIH 020S	ASP	100 Pa			150 Pa			200 Pa			250 Pa		
	Airflow (m³/h)	K	PI	RPM	K	PI	RPM	K	PI	RPM	K	PI	RPM
	3150	STD	1x0,55	682	STD	1x0,55	788	HP1	1x1,1	890	HP1	1x1,1	980
3425	STD	1x0,55	699	STD	1x0,55	800	HP1	1x1,1	896	HP1	1x1,1	984	
3700	STD	1x0,55	717	STD	1x0,55	813	HP1	1x1,1	909	HP1	1x1,1	991	
4100	STD	1x0,55	735	No kit			HP1	1x1,1	921	HP1	1x1,1	1003	
CIC/CIH 020S	ASP	300 Pa			350 Pa			400 Pa			550 Pa		
	Airflow (m³/h)	K	PI	RPM	K	PI	RPM	K	PI	RPM	K	PI	RPM
	3150	HP1	1x1,1	1060	HP2	1x1,1	1133	HP3	1x1,5	1204	HP3	1x1,5	1275
3425	HP1	1x1,1	1068	HP2	1x1,1	1135	HP3	1x1,5	1214	HP3	1x1,5	1281	
3700	HP1	1x1,1	1074	HP2	1x1,1	1138	HP3	1x1,5	1220	HP3	1x1,5	1289	
4100	HP1	1x1,1	1083	HP2	1x1,1	1141	HP3	1x1,5	1233	HP3	1x1,5	1293	

CIC/CIH 025S	ASP	100 Pa			150 Pa			200 Pa			250 Pa			300 Pa		
	Airflow (m³/h)	K	PI	RPM	K	PI	RPM	K	PI	RPM	K	PI	RPM	K	PI	RPM
	4250	STD	1x1,1	753	STD	1x1,1	840	HP1	1x1,5	915	HP1	1x1,5	1009	HP1	1x1,5	1085
4625	STD	1x1,1	770	HP1	1x1,5	860	HP1	1x1,5	942	HP1	1x1,5	1021	HP1	1x1,5	1098	
5000	STD	1x1,1	806	HP1	1x1,5	883	HP1	1x1,5	956	HP1	1x1,5	1035	HP2	1x1,5	1091	
5500	STD	1x1,1	840	HP1	1x1,5	903	HP1	1x1,5	988	HP1	1x1,5	1059	HP2	1x1,5	1098	
CIC/CIH 025S	ASP	350 Pa			400 Pa			450 Pa			500 Pa			550 Pa		
	Airflow (m³/h)	K	PI	RPM	K	PI	RPM	K	PI	RPM	K	PI	RPM	K	PI	RPM
	4250	HP2	1x1,5	1160	HP2	1x1,5	1233	HP2	1x1,5	1279	HP3	1x2,2	1358	HP3	1x2,2	1420
4625	HP2	1x1,5	1169	HP2	1x1,5	1238	HP2	1x1,5	1281	HP3	1x2,2	1364	HP3	1x2,2	1426	
5000	HP2	1x1,5	1176	HP2	1x1,5	1246	HP3	1x2,2	1310	HP3	1x2,2	1371	HP3	1x2,2	1431	
5500	HP3	1x2,2	1195	HP3	1x2,2	1258	HP3	1x2,2	1321	HP3	1x2,2	1380	HP3	1x2,2	1441	

CIC/CIH 030S	ASP	100 Pa			150 Pa			200 Pa			250 Pa			300 Pa		
	Airflow (m³/h)	K	PI	RPM	K	PI	RPM	K	PI	RPM	K	PI	RPM	K	PI	RPM
	4650	STD	1x1,1	797	STD	1x1,1	876	HP1	1x1,5	956	HP1	1x1,5	1038	HP2	1x2,2	1113
5050	STD	1x1,1	822	STD	1x1,1	903	HP1	1x1,5	980	HP1	1x1,5	1051	HP2	1x2,2	1126	
5450	STD	1x1,1	856	HP1	1x1,5	932	HP1	1x1,5	1003	HP1	1x1,5	1074	HP2	1x2,2	1141	
6000	STD	1x1,1	895	HP1	1x1,5	970	HP1	1x1,5	1034	HP1	1x1,5	1098	HP2	1x2,2	1161	
CIC/CIH 030S	ASP	350 Pa			400 Pa			450 Pa			500 Pa			550 Pa		
	Airflow (m³/h)	K	PI	RPM	K	PI	RPM	K	PI	RPM	K	PI	RPM	K	PI	RPM
	4650	HP2	1x2,2	1184	HP2	1x2,2	1251	HP2	1x2,2	1295	HP3	1x3	1380	HP3	1x3	1438
5050	HP2	1x2,2	1197	HP2	1x2,2	1261	HP2	1x2,2	1298	HP3	1x3	1386	HP3	1x3	1445	
5450	HP2	1x2,2	1208	HP2	1x2,2	1271	HP2	1x2,2	1303	HP3	1x3	1395	HP3	1x3	1453	
6000	HP2	1x2,2	1227	HP2	1x2,2	1278	HP3	1x3	1349	HP3	1x3	1407	HP3	1x3	1465	

<b>STD</b>	Standard fan	<b>HP1</b>	High pressure fan 1 (option)
<b>HP2</b>	High pressure fan 2 (option)	<b>HP3</b>	High pressure fan 3 (option)

**ASP** Available static pressure (Pa)

**PI (kW)** Power input

**TREATMENT VENTILATION DATA  
LARGE DUCTED SPLIT**

<b>CIC/CIH 035S</b>	ASP	100 Pa			150 Pa			200 Pa			250 Pa			300 Pa		
	Airflow (m³/h)	K	PI	RPM	K	PI	RPM	K	PI	RPM	K	PI	RPM	K	PI	RPM
	6200	STD	1x1,5	640	STD	1x1,5	720	HP1	1x2,2	788	HP1	1x2,2	849	HP1	1x2,2	912
	6650	STD	1x1,5	663	STD	1x1,5	735	HP1	1x2,2	797	HP1	1x2,2	863	HP1	1x2,2	922
	7100	STD	1x1,5	688	HP1	1x2,2	749	HP1	1x2,2	813	HP1	1x2,2	873	HP1	1x2,2	931
	8050	STD	1x1,5	735	HP1	1x2,2	788	HP1	1x2,2	848	HP1	1x2,2	903	HP2	1x3	956
	ASP	350 Pa			400 Pa			450 Pa			500 Pa			550 Pa		
	Airflow (m³/h)	K	PI	RPM	K	PI	RPM	K	PI	RPM	K	PI	RPM	K	PI	RPM
	6200	HP2	1x3	972	HP2	1x3	1028	HP2	1x3	1066	HP3	1x3	1134	HP3	1x3	1183
	6650	HP2	1x3	979	HP2	1x3	1035	HP2	1x3	1068	HP3	1x3	1139	HP3	1x3	1188
7100	HP2	1x3	986	HP2	1x3	1044	HP2	1x3	1071	HP3	1x3	1144	No kit			
8050	HP2	1x3	1010	HP2	1x3	1052	HP3	1x3	1111	HP3	1x3	1159				

<b>CIC/CIH 040S</b>	ASP	100 Pa			150 Pa			200 Pa			250 Pa			300 Pa			350 Pa		
	Airflow (m³/h)	K	PI	RPM	K	PI	RPM	K	PI	RPM	K	PI	RPM	K	PI	RPM	K	PI	RPM
	6950	STD	1x2,2	690	STD	1x2,2	757	STD	1x2,2	821	HP1	1x2,2	882	HP2	1x3	940	HP2	1x3	997
	7550	STD	1x2,2	726	STD	1x2,2	782	HP1	1x2,2	838	HP1	1x2,2	900	HP2	1x3	956	HP2	1x3	1010
	8150	STD	1x2,2	748	STD	1x2,2	808	HP1	1x2,2	863	HP1	1x2,2	919	HP2	1x3	973	HP2	1x3	1024
	9050	STD	1x2,2	799	HP1	1x2,2	851	HP1	1x2,2	902	HP2	1x3	951	HP2	1x3	1002	HP2	1x3	1069
	ASP	400 Pa			450 Pa			500 Pa			550 Pa			600 Pa					
	Airflow (m³/h)	K	PI	RPM	K	PI	RPM	K	PI	RPM	K	PI	RPM	K	PI	RPM			
	6950	HP2	1x3	1048	HP2	1x3	1103	HP3	1x4	1154	HP3	1x4	1202	HP3	1x4	1250	No kit		
	7550	HP2	1x3	1053	HP3	1x4	1117	HP3	1x4	1162	HP3	1x4	1209						
8150	HP2	1x3	1059	HP3	1x4	1125	HP3	1x4	1172	HP3	1x4	1216							
9050	HP2	1x3	1069	HP3	1x4	1144	HP3	1x4	1189	HP3	1x4	1233							

<b>CIC/CIH 045D</b>	ASP	100 Pa			150 Pa			200 Pa			250 Pa			300 Pa		
	Airflow (m³/h)	K	PI	RPM	K	PI	RPM	K	PI	RPM	K	PI	RPM	K	PI	RPM
	7950	STD	1x2,2	738	STD	1x2,2	800	HP1	1x3	857	HP1	1x3	912	HP1	1x3	967
	8675	STD	1x2,2	779	STD	1x2,2	833	HP1	1x3	886	HP1	1x3	938	HP1	1x3	986
	9400	STD	1x2,2	817	STD	1x2,2	867	HP1	1x3	917	HP1	1x3	966	HP1	1x3	1014
	9750	STD	1x2,2	838	HP1	1x3	884	HP1	1x3	931	HP1	1x3	979	HP1	1x3	1027
	ASP	350 Pa			400 Pa			450 Pa			500 Pa			550 Pa		
	Airflow (m³/h)	K	PI	RPM	K	PI	RPM	K	PI	RPM	K	PI	RPM	K	PI	RPM
	7950	HP1	1x3	1019	HP2	1x4	1058	HP3	1x4	1154	HP3	1x4	1168	HP3	1x4	1216
	8675	HP1	1x3	1041	HP2	1x4	1064	HP3	1x4	1136	HP3	1x4	1183	HP3	1x4	1226
9400	HP2	1x4	1052	HP2	1x4	1073	HP3	1x4	1150	HP3	1x4	1196	HP3	1x4	1240	
9750	HP2	1x4	1056	HP3	1x4	1117	HP3	1x4	1161	HP3	1x4	1204	HP3	1x4	1250	

<b>STD</b>	Standard fan	<b>HP1</b>	High pressure fan 1 (option)
<b>HP2</b>	High pressure fan 2 (option)	<b>HP3</b>	High pressure fan 3 (option)

**ASP** Available static pressure (Pa)

**PI (kW)** Power input

**TREATMENT VENTILATION DATA  
LARGE DUCTED SPLIT**

CIC/CIH 055D	ASP	100 Pa			150 Pa			200 Pa			250 Pa			300 Pa			350 Pa		
	Airflow (m³/h)	K	PI	RPM	K	PI	RPM	K	PI	RPM	K	PI	RPM	K	PI	RPM	K	PI	RPM
	9950	STD	1x2,2	666	STD	1x2,2	748	STD	1x2,2	828	HP1	1x3	903	HP1	1x3	967	HP1	1x3	1033
10825	STD	1x2,2	688	STD	1x2,2	770	HP1	1x3	842	HP1	1x3	913	HP1	1x3	986	HP1	1x3	1041	
11700	STD	1x2,2	704	STD	1x2,2	786	HP1	1x3	859	HP1	1x3	931	HP1	1x3	992	HP2	1x4	1010	
12850	STD	1x2,2	741	HP1	1x3	820	HP1	1x3	881	HP1	1x3	946	HP2	1x4	971	HP2	1x4	1027	
ASP	400 Pa			450 Pa			500 Pa			550 Pa			600 Pa			650 Pa			
Airflow (m³/h)	K	PI	RPM	K	PI	RPM	K	PI	RPM	K	PI	RPM	K	PI	RPM	K	PI	RPM	
9950	HP2	1x4	1047	HP2	1x4	1103	HP2	1x4	1138	HP3	1x5,5	1207	HP3	1x5,5	1256	HP3	1x5,5	1303	
10825	HP2	1x4	1057	HP2	1x4	0110	HP2	1x4	1140	HP3	1x5,5	1214	HP3	1x5,5	1262	HP3	1x5,5	1309	
11700	HP2	1x4	1065	HP2	1x4	1115	HP2	1x4	1172	HP3	1x5,5	1220	HP3	1x5,5	1268	No kit			
12850	HP2	1x4	1078	HP3	1x5,5	1132	HP3	1x5,5	1182	HP3	1x5,5	1232	No kit						

CIC/CIH 070D	ASP	100 Pa			150 Pa			200 Pa			250 Pa			300 Pa			350 Pa		
	Airflow (m³/h)	K	PI	RPM	K	PI	RPM	K	PI	RPM	K	PI	RPM	K	PI	RPM	K	PI	RPM
	12450	STD	1x3	738	STD	1x3	819	STD	1x3	888	HP1	1x4	959	HP1	1x4	1014	HP2	1x5,5	1033
13550	STD	1x3	776	STD	1x3	845	HP1	1x4	909	HP1	1x4	972	HP1	1x4	1033	HP2	1x5,5	1047	
14650	STD	1x3	807	HP1	1x4	871	HP1	1x4	931	HP1	1x4	993	HP2	1x5,5	1016	HP2	1x5,5	1069	
15090	STD	1x3	819	HP1	1x4	882	HP1	1x4	943	HP1	1x4	1002	HP2	1x5,5	1027	HP2	1x5,5	1078	
ASP	400 Pa			450 Pa			500 Pa			550 Pa			600 Pa			650 Pa			
Airflow (m³/h)	K	PI	RPM	K	PI	RPM	K	PI	RPM	K	PI	RPM	K	PI	RPM	K	PI	RPM	
12450	HP2	1x5,5	1087	HP2	1x5,5	1125	HP3	1x7,5	1189	HP3	1x7,5	1237	HP3	1x7,5	1275	HP3	1x7,5	1329	
13550	HP2	1x5,5	1101	HP2	1x5,5	1130	HP3	1x7,5	1197	HP3	1x7,5	1245	HP3	1x7,5	1292	HP3	1x7,5	1339	
14650	HP2	1x5,5	1113	HP2	1x5,5	1137	HP3	1x7,5	1212	HP3	1x7,5	1258	HP3	1x7,5	1303	No kit			
15090	HP2	1x5,5	1117	HP2	1x5,5	1140	HP3	1x7,5	1218	HP3	1x7,5	1264	HP3	1x7,5	1307				

CIC/CIH 085D	ASP	100 Pa			150 Pa			200 Pa			250 Pa			300 Pa			350 Pa		
	Airflow (m³/h)	K	PI	RPM	K	PI	RPM	K	PI	RPM	K	PI	RPM	K	PI	RPM	K	PI	RPM
	14000	STD	1x4	805	STD	1x4	872	STD	1x4	937	HP1	1x5,5	995	HP2	1x7,5	1016	HP2	1x7,5	1070
15125	STD	1x4	838	STD	1x4	898	HP1	1x5,5	959	HP1	1x5,5	1014	HP2	1x7,5	1040	HP2	1x7,5	1088	
16250	STD	1x4	863	STD	1x4	925	HP1	1x5,5	986	HP1	1x5,5	1041	HP2	1x7,5	1064	HP2	1x7,5	1110	
16725	STD	1x4	882	STD	1x4	937	HP1	1x5,5	994	HP2	1x7,5	1029	HP2	1x7,5	1073	HP2	1x7,5	1114	
ASP	400 Pa			450 Pa			500 Pa			550 Pa			600 Pa						
Airflow (m³/h)	K	PI	RPM	K	PI	RPM	K	PI	RPM	K	PI	RPM	K	PI	RPM				
14000	HP2	1x7,5	1114	HP2	1x7,5	1172	HP3	1x7,5	1214	HP3	1x7,5	1262	HP3	1x7,5	1303				
15125	HP2	1x7,5	1122	HP3	1x7,5	1184	HP3	1x7,5	1232	HP3	1x7,5	1275	HP3	1x7,5	1310				
16250	HP2	1x7,5	1130	HP3	1x7,5	1201	HP3	1x7,5	1245	HP3	1x7,5	1289	HP3	1x7,5	1331				
16725	HP2	1x7,5	1134	HP3	1x7,5	1209	HP3	1x7,5	1253	HP3	1x7,5	1295	HP3	1x7,5	1339				

<b>STD</b>	Standard fan	<b>HP1</b>	High pressure fan 1 (option)
<b>HP2</b>	High pressure fan 2 (option)	<b>HP3</b>	High pressure fan 3 (option)

**TREATMENT VENTILATION DATA  
LARGE DUCTED SPLIT**

<b>CIC/CIH 100D</b>	ASP	100 Pa			150 Pa			200 Pa			250 Pa			300 Pa			350 Pa		
	Airflow (m³/h)	K	PI	RPM	K	PI	RPM	K	PI	RPM	K	PI	RPM	K	PI	RPM	K	PI	RPM
	17350	STD	1x4	591	STD	1x4	650	STD	1x4	710	HP1	1x5,5	763	HP1	1x5,5	815	HP2	2x4	825
	18875	STD	1x4	611	STD	1x4	670	STD	1x4	730	HP1	1x5,5	777	HP1	1x5,5	827	HP2	2x4	834
	20400	STD	1x4	637	STD	1x4	690	HP1	1x5,5	744	HP1	1x5,5	792	HP2	2x4	802	HP2	2x4	846
	22450	STD	1x4	670	HP1	1x5,5	721	HP1	1x5,5	770	HP2	2x4	788	HP2	2x4	822	HP2	2x4	863
	ASP	400 Pa			450 Pa			500 Pa			550 Pa			600 Pa					
	Airflow (m³/h)	K	PI	RPM	K	PI	RPM	K	PI	RPM	K	PI	RPM	K	PI	RPM			
	17350	HP2	2x4	870	HP2	2x4	903	HP3	2x4	959	HP3	2x4	997	HP3	2x4	1036			
	18875	HP2	2x4	879	HP2	2x4	906	HP3	2x4	964	HP3	2x4	1003	HP3	2x4	1041			
20400	HP2	2x4	888	HP2	2x4	910	HP3	2x4	971	HP3	2x4	1009	No kit						
22450	HP2	2x4	896	HP3	2x4	945	HP3	2x4	986	No kit									

<b>CIC/CIH 120D</b>	ASP	100 Pa			150 Pa			200 Pa			250 Pa			300 Pa		
	Airflow (m³/h)	K	PI	RPM	K	PI	RPM	K	PI	RPM	K	PI	RPM	K	PI	RPM
	21000	STD	1x5,5	630	STD	1x5,5	690	STD	1x5,5	743	HP1	1x7,5	792	HP2	2x4	802
	22250	STD	1x5,5	658	STD	1x5,5	710	HP1	1x7,5	763	HP1	1x7,5	810	HP2	2x4	818
	23500	STD	1x5,5	690	STD	1x5,5	736	HP1	1x7,5	784	HP1	1x7,5	829	HP2	2x4	838
	24750	STD	1x5,5	722	HP1	1x7,5	770	HP1	1x7,5	815	HP2	2x4	817	HP2	2x4	858
	ASP	350 Pa			400 Pa			450 Pa			500 Pa			550 Pa		
	Airflow (m³/h)	K	PI	RPM	K	PI	RPM	K	PI	RPM	K	PI	RPM	K	PI	RPM
	21000	HP2	2x4	848	HP2	2x4	888	HP2	1x4	937	HP3	2x5,5	974	HP3	2x5,5	1014
	22250	HP2	2x4	863	HP2	2x4	899	HP3	2x5,5	945	HP3	2x5,5	986	HP3	2x5,5	1022
23500	HP2	2x4	876	HP2	2x4	902	HP3	2x5,5	959	HP3	2x5,5	994	HP3	2x5,5	1031	
24750	HP2	2x4	892	HP2	2x4	910	HP3	2x5,5	974	HP3	1x5,5	1010	No kit			

<b>CIC/CIH 140D</b>	ASP	100 Pa			150 Pa			200 Pa			250 Pa			300 Pa			350 Pa		
	Airflow (m³/h)	K	PI	RPM	K	PI	RPM	K	PI	RPM	K	PI	RPM	K	PI	RPM	K	PI	RPM
	21000	STD	1x5,5	611	STD	1x5,5	665	STD	1x5,5	718	HP1	1x7,5	770	HP1	1x7,5	815	HP2	2x4	823
	22250	STD	1x5,5	630	STD	1x5,5	681	STD	1x5,5	730	HP1	1x7,5	780	HP1	1x7,5	827	HP2	2x4	832
	23500	STD	1x5,5	650	STD	1x5,5	697	STD	1x5,5	750	HP1	1x7,5	792	HP1	1x7,5	837	HP2	2x4	841
	24750	STD	1x5,5	665	STD	1x5,5	710	HP1	1x7,5	761	HP1	1x7,5	806	HP2	2x4	813	HP2	2x4	851
	ASP	400 Pa			450 Pa			500 Pa			550 Pa			600 Pa					
	Airflow (m³/h)	K	PI	RPM	K	PI	RPM	K	PI	RPM	K	PI	RPM	K	PI	RPM			
	21000	HP2	2x4	867	HP2	2x4	900	HP3	2x5,5	949	HP3	2x5,5	986	HP3	2x5,5	1026			
	22250	HP2	2x4	875	HP2	2x4	903	HP3	2x5,5	954	HP3	2x5,5	993	HP3	2x5,5	1030			
23500	HP2	2x4	882	HP2	2x4	906	HP3	2x5,5	959	HP3	2x5,5	999	HP3	2x5,5	1035				
24750	HP2	2x4	890	HP2	2x4	910	HP3	2x5,5	968	HP3	2x5,5	1004	HP3	2x5,5	1041				

<b>STD</b>	Standard fan	<b>HP1</b>	High pressure fan 1 (option)
<b>HP2</b>	High pressure fan 2 (option)	<b>HP3</b>	High pressure fan 3 (option)

**ASP** Available static pressure (Pa)

**PI (kW)** Power input

**RETURN VENTILATION DATA**

<b>055D</b>			Airflow (m³/h)								
			9950		10825		11700		12850		
Airflow (rpm) ↓			ASP	PI	ASP	PI	ASP	PI	ASP	PI	
Closed pulley			<b>755</b>	255	2,37	257	2,56	260	2,77	260	3,05
Pulley position	1 turn	<b>715</b>	230	2,11	232	2,30	234	2,48	233	2,75	
	2 turns	<b>675</b>	207	1,88	208	2,05	210	2,23	207	2,48	
	3 turns	<b>635</b>	184	1,67	184	1,82	184	1,99	180	2,22	
	4 turns	<b>595</b>	162	1,47	162	1,61	160	1,77	155	1,98	

<b>070D</b>			Airflow (m³/h)								
			12450		13550		14650		15090		
Airflow (rpm) ↓			ASP	PI	ASP	PI	ASP	PI	ASP	PI	
Closed pulley			<b>755</b>	260	2,93	260	3,22	258	3,52	255	3,65
Pulley position	1 turn	<b>715</b>	235	2,64	233	2,91	228	3,20	225	3,32	
	2 turns	<b>675</b>	208	2,37	205	2,62	198	2,90	195	3,00	
	3 turns	<b>635</b>	182	2,12	176	2,36	168	2,61	165	2,72	
	4 turns	<b>595</b>	157	1,89	150	2,11	140	2,35	135	2,44	

<b>085D</b>			Airflow (m³/h)								
			14000		15125		16250		16725		
Airflow (rpm) ↓			ASP	PI	ASP	PI	ASP	PI	ASP	PI	
Closed pulley			<b>755</b>	260	3,44	255	3,77	250	4,13	•	•
Pulley position	1 turn	<b>715</b>	230	3,12	225	3,43	215	3,75	212	3,90	
	2 turns	<b>675</b>	202	2,82	195	3,11	183	3,41	178	3,55	
	3 turns	<b>635</b>	173	2,53	165	2,80	153	3,09	145	3,22	
	4 turns	<b>595</b>	145	2,27	135	2,52	120	2,79	115	2,91	

<b>100D</b>			Airflow (m³/h)								
			17350		18875		20400		22450		
Airflow (rpm) ↓			ASP	PI	ASP	PI	ASP	PI	ASP	PI	
Closed pulley			<b>672</b>	293	3,81	293	4,25	291	4,60	•	•
Pulley position	1 turn	<b>636</b>	263	3,46	261	2,88	258	4,22	251	4,77	
	2 turns	<b>601</b>	234	3,15	232	3,49	227	3,86	218	4,38	
	3 turns	<b>565</b>	205	2,83	202	3,15	196	3,48	185	3,98	
	4 turns	<b>529</b>	178	2,52	173	2,81	166	3,13	153	3,58	

<b>120D</b>			Airflow (m³/h)								
			19300		21000		22700		24750		
Airflow (rpm) ↓			ASP	PI	ASP	PI	ASP	PI	ASP	PI	
Closed pulley			<b>766</b>	381		380		380		373	
Pulley position	1 turn	<b>725</b>	343		340		337		330		
	2 turns	<b>684</b>	305		300		297		287		
	3 turns	<b>644</b>	268		263		257		245		
	4 turns	<b>603</b>	232		227		220		205		

<b>140D</b>			Airflow (m³/h)						
			21000		22700		24750		
Airflow (rpm) ↓			ASP	PI	ASP	PI	ASP	PI	
Closed pulley			<b>766</b>	380		380		373	
Pulley position	1 turn	<b>725</b>	340		337		330		
	2 turns	<b>684</b>	300		297		287		
	3 turns	<b>644</b>	263		257		245		
	4 turns	<b>603</b>	227		220		205		

**EXHAUST VENTILATION DATA**

		<b>020S - 025S - 030S</b>		
Airflow	m³/h	2000	2500	2750
Available static pressure	Pa	160	105	75

		<b>035S - 040S - 042S - 045D</b>		
Airflow	m³/h	3000	3500	4000
Available static pressure	Pa	210	180	130

		<b>060S-070S-055D-070D-85D</b>		
Airflow	m³/h	6000	7000	8000
Available static pressure	Pa	260	200	90

		<b>100D</b>			
Airflow	m³/h	13200	14300	15400	16500
Available static pressure	Pa	230	200	150	50

		<b>120D - 140D</b>			
Airflow	m³/h	13200	14300	15400	16500
Available static pressure	Pa	230	200	150	50

**OPTION PRESSURE DROP TABLE**

Unit size		020S				025S				030S				035S			
<b>Airflow</b>	m <sup>3</sup> /h	3150	3425	3700	4100	4250	4625	5000	5500	4650	5050	5450	6000	6200	6650	7100	8050
Options																	
Economizer	Pa	13	17	20	25	24	31	37	45	28	37	43	54	26	30	34	43
G4/F7 filtration		85	93	102	115	120	133	146	165	133	148	163	184	128	140	152	178
Hot water coil		15	17	20	23	25	28	32	38	29	33	37	44	25	29	32	39

Unit size		040S / 042S				045D				055D / 060S			
<b>Airflow</b>	m <sup>3</sup> /h	6950	7550	8150	9050	7950	8675	9400	9750	9950	10825	11700	12850
Options													
Economizer	Pa	33	38	44	52	42	48	55	58	11	13	16	19
G4/F7 filtration		148	164	181	208	175	197	219	230	123	136	150	169
Hot water coil		31	35	40	47	38	44	50	54	24	27	31	36

Unit size		070D / 070S				085D				100D			
<b>Airflow</b>	m <sup>3</sup> /h	12450	13550	14650	15090	14000	15125	16250	16725	17350	18875	20400	22450
Options													
Economizer	Pa	18	21	24	26	22	26	30	32	5	10	15	20
G4/F7 filtration		162	181	200	208	188	209	230	239	135	150	166	187
Hot water coil		34	39	44	47	41	47	53	55	23	26	30	35

Unit size		120D				140D			
<b>Airflow</b>	m <sup>3</sup> /h	19300	21000	22700	24950	21000	22250	23500	24750
Options									
Economizer	Pa	15	20	25	30	20	25	30	35
G4/F7 filtration		154	172	190	215	133	143	153	164
Hot water coil		27	31	35	41	31	34	37	41

**COOLING CAPACITIES**

ASC/ASH + CIC/CIH 020S			Air inlet temperature at condenser (dry bulb)																		
Airflow m <sup>3</sup> /h	Indoor wet bulb °C	Indoor dry bulb °C	20 °C			25 °C			30 °C			35 °C			40 °C			45 °C			
			GC	SC	AC	GC	SC	AC	GC	SC	AC	GC	SC	AC	GC	SC	AC	GC	SC	AC	
Minimum	3150	16	21	19,6	12,1	4,4	19,1	11,9	4,7	11,6	18,4	5,1	17,7	11,2	5,6	16,9	10,9	6,3	15,9	10,4	7,2
			24	19,7	14,7	4,4	19,2	14,4	4,7	14,1	18,5	5,1	17,8	13,8	5,6	17,0	13,3	6,3	16,0	12,8	7,2
			27	19,7	17,3	4,4	19,2	17,0	4,7	16,7	18,6	5,1	17,9	16,3	5,6	17,0	15,8	6,3	16,1	15,2	7,2
		19	24	21,4	11,9	4,6	20,8	11,7	4,9	11,4	20,1	5,3	19,3	11,0	5,8	18,4	10,7	6,4	17,4	10,3	7,4
			27	21,5	14,5	4,6	20,9	14,2	4,9	13,9	20,2	5,3	19,4	13,6	5,8	18,5	13,2	6,4	17,5	12,7	7,4
			30	21,5	17,0	4,6	20,9	16,7	4,9	16,4	20,3	5,3	19,5	16,1	5,8	18,6	15,6	6,5	17,6	15,1	7,4
		22	27	23,3	11,7	4,7	22,7	11,4	5,0	11,1	21,9	5,4	21,1	10,8	6,0	20,1	10,5	6,6	19,1	10,1	7,6
			30	23,4	14,2	4,7	22,8	13,9	5,0	13,6	22,0	5,5	21,2	13,3	6,0	20,2	12,9	6,6	19,2	12,5	7,6
			33	23,5	16,6	4,7	22,8	16,4	5,1	16,1	22,1	5,5	21,3	15,8	6,0	20,3	15,4	6,7	19,3	14,9	7,6
Nominal	3700	16	21	20,1	12,6	4,5	19,5	12,4	4,9	12,1	18,9	5,3	18,1	11,7	5,8	17,2	11,3	6,4	16,3	10,9	7,4
			24	20,2	15,5	4,5	19,6	15,3	4,9	15,0	19,0	5,3	18,2	14,6	5,8	17,4	14,1	6,4	16,4	13,5	7,4
			27	20,3	18,4	4,5	19,7	18,2	4,9	17,8	19,1	5,3	18,3	17,4	5,8	17,4	16,8	6,4	16,5	15,9	7,4
		19	24	21,9	12,4	4,7	21,3	12,1	5,0	11,8	20,6	5,4	19,8	11,5	5,9	18,8	11,2	6,6	17,8	10,7	7,6
			27	22,0	15,3	4,7	21,4	15,0	5,0	14,7	20,7	5,4	19,9	14,4	5,9	19,0	13,9	6,6	17,9	13,4	7,6
			30	22,1	18,2	4,7	21,5	17,9	5,0	17,6	20,8	5,4	20,0	17,2	6,0	19,0	16,7	6,6	18,0	16,1	7,6
		22	27	23,9	12,1	4,8	23,2	11,8	5,2	11,6	22,4	5,6	21,6	11,3	6,1	20,6	10,9	6,8	19,5	10,6	7,8
			30	24,0	15,0	4,8	23,3	14,7	5,2	14,4	22,6	5,6	21,7	14,1	6,1	20,7	13,7	6,8	19,6	13,3	7,8
			33	24,1	17,8	4,8	23,4	17,6	5,2	17,3	22,6	5,6	21,8	16,9	6,1	20,8	16,5	6,8	19,7	16,0	7,8
Maximum	4100	16	21	20,5	13,0	4,5	19,9	12,8	4,8	12,5	19,2	5,2	18,4	12,1	5,7	17,5	11,7	6,4	16,5	11,3	7,3
			24	20,6	16,2	4,5	20,0	15,9	4,8	15,6	19,3	5,2	18,5	15,2	5,7	17,7	14,7	6,4	16,7	14,1	7,3
			27	20,7	19,3	4,5	20,1	19,0	4,8	18,7	19,4	5,2	18,7	18,2	5,7	17,8	17,7	6,4	16,8	17,0	7,3
		19	24	22,3	12,8	4,7	21,7	12,5	5,0	12,2	20,9	5,4	20,1	11,9	5,9	19,1	11,5	6,5	18,1	11,1	7,5
			27	22,4	15,9	4,7	21,8	15,7	5,0	15,3	21,1	5,4	20,2	15,0	5,9	19,3	14,5	6,6	18,2	14,0	7,5
			30	22,5	19,1	4,7	21,9	18,8	5,0	18,5	21,2	5,4	20,3	18,0	5,9	19,4	17,5	6,6	18,3	16,9	7,5
		22	27	24,3	12,4	4,8	23,6	12,2	5,2	11,9	22,8	5,6	21,9	11,6	6,1	20,9	11,3	6,8	19,8	10,9	7,7
			30	24,4	15,6	4,8	23,7	15,3	5,2	15,0	22,9	5,6	22,0	14,7	6,1	21,0	14,3	6,8	19,9	13,8	7,7
			33	24,5	18,7	4,8	23,8	18,5	5,2	18,1	23,0	5,6	22,1	17,8	6,1	21,1	17,3	6,8	20,0	16,8	7,7

**HEATING CAPACITIES**

ASH+CIH 020S			Air inlet temperature at condenser (dry bulb)													
Airflow m <sup>3</sup> /h	Indoor dry bulb °C	-10 °C		-5 °C		0 °C		5 °C		7 °C		10 °C		15 °C		
		NH	AC	NH	AC	NH	AC	NH	AC	NH	AC	NH	AC	NH	AC	
Minimum	3150	15	12,6	3,88	14,6	4,31	16,6	4,74	18,7	5,17	19,5	5,35	20,6	5,62	22,6	6,09
		18	12,6	4,21	14,6	4,65	16,5	5,09	18,5	5,54	19,3	5,73	20,5	6,01	22,4	6,52
		20	12,6	4,44	14,6	4,89	16,5	5,34	18,5	5,81	19,2	6,00	20,4	6,30	22,3	6,82
		23	12,6	4,82	14,5	5,28	16,5	5,75	18,4	6,24	19,1	6,44	20,3	6,76	22,1	7,32
		25	12,6	5,10	14,5	5,56	16,4	6,04	18,3	6,55	19,1	6,76	20,2	7,09	22,0	7,69
Nominal	3700	15	12,7	3,77	14,8	4,17	16,9	4,56	18,9	4,95	19,7	5,11	20,9	5,35	23,0	5,78
		19	12,7	4,20	14,7	4,60	16,7	5,01	18,7	5,42	19,5	5,59	20,7	5,85	22,7	6,31
		20	12,7	4,31	14,7	4,72	16,7	5,13	18,7	5,55	19,5	5,72	20,7	5,98	22,6	6,45
		23	12,7	4,68	14,7	5,10	16,6	5,52	18,6	5,95	19,4	6,13	20,5	6,41	22,5	6,91
		25	12,7	4,96	14,7	5,37	16,6	5,80	18,5	6,25	19,3	6,43	20,4	6,72	22,4	7,24
Maximum	4100	15	12,7	3,64	14,9	4,02	17,0	4,38	19,0	4,75	19,9	4,90	21,1	5,13	23,2	5,52
		19	12,7	4,05	14,8	4,44	16,8	4,82	18,8	5,20	19,7	5,36	20,9	5,60	22,9	6,01
		20	12,7	4,17	14,7	4,55	16,8	4,93	18,8	5,32	19,6	5,48	20,8	5,72	22,8	6,15
		23	12,7	4,53	14,7	4,92	16,7	5,31	18,7	5,71	19,5	5,87	20,6	6,13	22,6	6,58
		25	12,7	4,79	14,7	5,18	16,6	5,58	18,6	5,99	19,4	6,15	20,6	6,42	22,5	6,88
27	12,7	5,08	14,7	5,46	16,6	5,86	18,5	6,28	19,3	6,45	20,7	6,73	22,4	7,21		

<b>Indoor fan power input (kw)</b>			
Minimum airflow	0,31	Nominal airflow	0,38
Maximum airflow			0,44
<b>Outdoor fan power input (kw)</b>			
Nominal airflow	0,4		

<b>GC (kW)</b> :	Gross cooling capacity	<b>NH (kW)</b> :	Net heating capacity	<b>SC (kW)</b> :	Sensible cooling capacity	<b>AC (kW)</b> :	Compressor absorbed power
------------------	------------------------	------------------	----------------------	------------------	---------------------------	------------------	---------------------------



**COOLING CAPACITIES**

ASC/ASH + CIC/CIH 025S			Air inlet temperature at condenser (dry bulb)																		
Airflow m³/h	Indoor wet bulb °C	Indoor dry bulb °C	20 °C			25 °C			30 °C			35 °C			40 °C			45 °C			
			GC	SC	AC	GC	SC	AC	GC	SC	AC	GC	SC	AC	GC	SC	AC	GC	SC	AC	
Minimum	4250	16	21	24,1	14,8	5,1	23,4	14,5	5,5	22,7	14,1	6,0	21,8	13,7	6,6	20,7	13,3	7,3	19,6	12,7	8,4
			24	24,2	18,0	5,2	23,5	17,7	5,5	22,8	17,3	6,0	21,9	16,9	6,6	20,9	16,4	7,3	19,7	15,8	8,4
			27	24,2	21,2	5,2	23,6	20,9	5,5	22,8	20,6	6,0	21,9	20,1	6,6	20,9	19,5	7,3	19,8	18,8	8,4
		19	24	26,2	14,5	5,3	25,5	14,2	5,7	24,7	13,8	6,1	23,7	13,4	6,7	22,6	13,0	7,5	21,4	12,5	8,6
			27	26,3	17,7	5,3	25,6	17,4	5,7	24,8	17,0	6,2	23,8	16,6	6,7	22,7	16,1	7,5	21,5	15,6	8,6
			30	26,4	20,9	5,3	25,7	20,6	5,7	24,9	20,2	6,2	23,9	19,8	6,7	22,8	19,2	7,5	21,6	18,6	8,6
		22	27	28,5	14,2	5,5	27,7	13,9	5,8	26,8	13,5	6,3	25,8	13,1	6,9	24,6	12,7	7,7	23,3	12,3	8,8
			30	28,6	17,3	5,5	27,8	17,0	5,9	26,9	16,7	6,3	25,9	16,3	6,9	24,7	15,8	7,7	23,4	15,3	8,8
			33	28,7	20,4	5,5	27,9	20,1	5,9	27,0	19,8	6,3	26,0	19,4	6,9	24,8	18,9	7,7	23,5	18,3	8,8
Nominal	5000	16	21	24,5	15,2	5,4	23,8	14,9	5,8	23,0	14,5	6,3	22,1	14,1	6,9	21,0	13,7	7,7	19,8	13,1	8,9
			24	24,6	18,8	5,4	23,9	18,5	5,8	23,1	18,1	6,3	22,2	17,7	6,9	21,2	17,1	7,7	20,0	16,4	8,9
			27	24,7	22,4	5,4	24,0	22,1	5,8	23,2	21,7	6,3	22,3	21,2	6,9	21,2	20,5	7,7	20,2	19,5	8,8
		19	24	26,7	14,9	5,6	25,9	14,6	6,0	25,0	14,2	6,5	24,0	13,8	7,1	22,9	13,4	7,9	21,6	12,9	9,1
			27	26,8	18,5	5,6	26,1	18,2	6,0	25,2	17,8	6,5	24,2	17,4	7,1	23,0	16,9	7,9	21,8	16,3	9,1
			30	26,9	22,1	5,6	26,2	21,8	6,0	25,3	21,4	6,5	24,3	20,9	7,1	23,2	20,3	7,9	21,9	19,6	9,1
		22	27	29,0	14,5	5,7	28,2	14,2	6,1	27,2	13,9	6,6	26,1	13,5	7,3	24,9	13,1	8,1	23,6	12,6	9,3
			30	29,1	18,1	5,7	28,3	17,8	6,2	27,4	17,4	6,7	26,3	17,0	7,3	25,1	16,6	8,1	23,8	16,0	9,3
			33	29,3	21,6	5,8	28,4	21,4	6,2	27,5	21,0	6,7	26,4	20,5	7,3	25,2	20,0	8,2	23,9	19,4	9,3
Maximum	5500	16	21	24,9	15,6	5,4	24,2	15,3	5,8	23,4	15,0	6,2	22,4	14,5	6,8	21,3	14,0	7,5	20,1	13,5	8,6
			24	25,0	19,5	5,4	24,3	19,2	5,8	23,5	18,8	6,2	22,6	18,3	6,8	21,5	17,7	7,5	20,3	17,0	8,6
			27	25,1	23,4	5,4	24,4	23,1	5,8	23,6	22,6	6,2	22,9	22,1	6,9	21,9	21,1	7,7	20,7	19,9	8,8
		19	24	27,1	15,3	5,5	26,3	15,0	5,9	25,4	14,6	6,4	24,4	14,2	7,0	23,2	13,8	7,7	22,0	13,3	8,8
			27	27,3	19,2	5,6	26,5	18,9	5,9	25,6	18,5	6,4	24,6	18,0	7,0	23,4	17,5	7,7	22,1	16,9	8,8
			30	27,4	23,1	5,6	26,6	22,8	5,9	25,7	22,4	6,4	24,7	21,8	7,0	23,5	21,2	7,8	22,2	20,5	8,8
		22	27	29,5	14,9	5,7	28,6	14,5	6,1	27,6	14,2	6,6	26,5	13,9	7,2	25,3	13,4	8,0	23,9	13,0	9,1
			30	29,6	18,8	5,7	28,8	18,4	6,1	27,8	18,1	6,6	26,7	17,7	7,2	25,5	17,2	8,0	24,1	16,6	9,1
			33	29,7	22,6	5,7	28,9	22,3	6,1	27,9	21,9	6,6	26,8	21,5	7,2	25,6	20,9	8,0	24,2	20,3	9,1

**HEATING CAPACITIES**

ASH+CIH 025S		Air inlet temperature at condenser (dry bulb)														
Airflow m³/h	Indoor dry bulb °C	-10 °C		-5 °C		0 °C		5 °C		7 °C		10 °C		15 °C		
		NH	AC	NH	AC	NH	AC	NH	AC	NH	AC	NH	AC	NH	AC	
Minimum	4250	15	16,1	4,79	18,7	5,27	21,24	5,7	23,75	6,2	24,75	6,4	26,23	6,7	28,67	7,30
		18	16,0	5,17	18,6	5,67	21,10	6,2	23,57	6,7	24,54	6,9	26,00	7,2	28,39	7,80
		20	16,0	5,45	18,5	5,96	21,01	6,5	23,44	7,0	24,41	7,2	25,84	7,6	28,20	8,17
		23	15,9	5,91	18,4	6,42	20,87	6,9	23,26	7,5	24,21	7,7	25,61	8,1	27,93	8,78
		25	15,9	6,24	18,4	6,77	20,79	7,3	23,14	7,9	24,08	8,1	25,46	8,5	27,75	9,23
		27	15,9	6,60	18,3	7,13	20,70	7,7	23,03	8,3	23,95	8,6	25,32	8,9	27,57	9,71
Nominal	5000	15	16,5	4,76	19,1	5,20	21,75	5,6	24,32	6,1	25,34	6,2	26,86	6,5	29,36	7,00
		19	16,4	5,29	19,0	5,73	21,56	6,2	24,07	6,6	25,07	6,8	26,55	7,1	28,99	7,63
		20	16,4	5,43	18,9	5,87	21,52	6,3	24,01	6,8	25,00	6,9	26,47	7,3	28,89	7,81
		23	16,4	5,89	18,9	6,33	21,38	6,8	23,83	7,3	24,80	7,5	26,24	7,8	28,62	8,36
		25	16,3	6,22	18,8	6,66	21,29	7,1	23,71	7,6	24,67	7,8	26,09	8,2	28,43	8,77
		27	16,3	6,58	18,8	7,02	21,21	7,5	23,59	8,0	24,54	8,2	25,94	8,6	28,25	9,21
Maximum	5500	15	16,5	4,61	19,2	5,02	21,86	5,4	24,48	5,8	25,52	6,0	27,06	6,2	29,60	6,69
		19	16,5	5,12	19,1	5,53	21,68	5,9	24,23	6,3	25,24	6,5	26,74	6,8	29,22	7,28
		20	16,4	5,26	19,1	5,67	21,63	6,1	24,17	6,5	25,17	6,7	26,67	6,9	29,13	7,44
		23	16,4	5,70	18,9	6,11	21,50	6,5	23,98	7,0	24,97	7,1	26,44	7,4	28,85	7,96
		25	16,4	6,03	18,9	6,43	21,41	6,8	23,87	7,3	24,84	7,5	26,29	7,8	28,67	8,33
		27	16,3	6,37	18,9	6,77	21,32	7,2	23,75	7,7	24,71	7,9	26,14	8,2	28,49	8,73

<b>Indoor fan power input (kw)</b>			
Minimum airflow	0,54	Nominal airflow	0,69
Maximum airflow			0,80
<b>Outdoor fan power input (kw)</b>			
Nominal airflow	0,67		

<b>GC (kW)</b> :	Gross cooling capacity	<b>NH (kW)</b> :	Net heating capacity	<b>SC (kW)</b> :	Sensible cooling capacity	<b>AC (kW)</b> :	Compressor absorbed power
------------------	------------------------	------------------	----------------------	------------------	---------------------------	------------------	---------------------------

**COOLING CAPACITIES**

ASC/ASH + CIC/CIH 030S			Air inlet temperature at condenser (dry bulb)																		
Airflow m³/h	Indoor wet bulb °C	Indoor dry bulb °C	20 °C			25 °C			30 °C			35 °C			40 °C			45 °C			
			GC	SC	AC	GC	SC	AC	GC	SC	AC	GC	SC	AC	GC	SC	AC	GC	SC	AC	
Minimum	4650	16	21	27,9	17,0	5,9	27,1	16,6	6,3	26,2	16,2	6,9	25,1	15,7	7,6	23,8	15,1	8,5	22,3	14,4	9,8
			24	28,0	20,6	5,9	27,2	20,3	6,3	26,3	19,8	6,9	25,1	19,2	7,6	23,8	18,6	8,5	22,4	17,8	9,9
			27	28,1	24,3	5,9	27,3	23,9	6,3	26,3	23,4	6,9	25,2	22,8	7,6	23,9	22,0	8,5	22,4	21,1	9,9
		19	24	30,4	16,7	6,0	29,5	16,3	6,5	28,5	15,9	7,1	27,3	15,4	7,8	25,9	14,8	8,7	24,3	14,2	10,1
			27	30,5	20,3	6,0	29,6	19,9	6,5	28,6	19,5	7,1	27,4	18,9	7,8	26,0	18,3	8,7	24,4	17,6	10,1
			30	30,6	23,9	6,0	29,7	23,5	6,5	28,7	23,0	7,1	27,5	22,5	7,8	26,1	21,8	8,7	24,5	20,9	10,1
		22	27	33,1	16,3	6,2	32,1	15,9	6,7	31,0	15,5	7,2	29,7	15,1	8,0	28,2	14,6	8,9	26,6	14,0	10,3
			30	33,2	19,8	6,2	32,2	19,5	6,7	31,1	19,0	7,3	29,8	18,6	8,0	28,3	18,0	8,9	26,7	17,3	10,3
			33	33,3	23,3	6,2	32,3	23,0	6,7	31,2	22,6	7,3	29,9	22,1	8,0	28,4	21,4	9,0	26,8	20,7	10,3
Nominal	5450	16	21	28,5	17,5	6,2	27,7	17,1	6,6	26,6	16,7	7,2	25,5	16,2	8,0	24,1	15,6	9,0	22,6	14,9	10,4
			24	28,6	21,6	6,2	27,8	21,2	6,6	26,8	20,7	7,2	25,6	20,1	8,0	24,2	19,4	9,0	22,7	18,5	10,4
			27	28,7	25,6	6,2	27,8	25,2	6,6	26,8	24,7	7,2	25,7	24,0	8,0	24,3	23,2	9,0	23,0	22,1	10,2
		19	24	31,0	17,2	6,3	30,1	16,8	6,8	29,0	16,3	7,4	27,7	15,9	8,1	26,3	15,3	9,2	24,7	14,7	10,6
			27	31,1	21,2	6,3	30,2	20,8	6,8	29,1	20,4	7,4	27,9	19,8	8,2	26,4	19,2	9,2	24,8	18,4	10,6
			30	31,2	25,2	6,3	30,3	24,9	6,8	29,2	24,4	7,4	27,9	23,8	8,2	26,5	23,0	9,2	24,9	22,1	10,6
		22	27	33,7	16,7	6,5	32,7	16,3	7,0	31,5	15,9	7,6	30,2	15,5	8,3	28,7	15,0	9,4	27,0	14,4	10,8
			30	33,8	20,7	6,5	32,8	20,4	7,0	31,7	19,9	7,6	30,3	19,4	8,4	28,8	18,8	9,4	27,1	18,2	10,8
			33	33,9	24,7	6,5	32,9	24,4	7,0	31,8	23,9	7,6	30,4	23,4	8,4	28,9	22,7	9,4	27,2	21,9	10,9
Maximum	6000	16	21	29,0	18,0	6,1	28,1	17,6	6,6	27,1	17,2	7,1	25,9	16,7	7,8	24,5	16,0	8,7	23,0	15,3	10,0
			24	29,1	22,4	6,1	28,3	22,0	6,6	27,2	21,5	7,1	26,0	20,9	7,8	24,6	20,1	8,7	23,1	19,2	10,0
			27	29,2	26,8	6,1	28,3	26,4	6,6	27,3	25,8	7,1	26,1	25,1	7,8	25,0	24,0	8,9	23,6	22,6	10,1
		19	24	31,6	17,6	6,3	30,6	17,2	6,7	29,5	16,8	7,3	28,2	16,3	8,0	26,7	15,8	8,9	25,1	15,1	10,3
			27	31,7	22,0	6,3	30,7	21,6	6,7	29,6	21,1	7,3	28,3	20,6	8,0	26,9	19,9	8,9	25,2	19,1	10,3
			30	31,8	26,4	6,3	30,8	26,0	6,7	29,7	25,5	7,3	28,4	24,8	8,0	27,0	24,0	9,0	25,3	23,1	10,3
		22	27	34,3	17,1	6,4	33,3	16,8	6,9	32,1	16,4	7,5	30,7	15,9	8,2	29,1	15,4	9,2	27,4	14,8	10,5
			30	34,4	21,5	6,5	33,4	21,1	6,9	32,2	20,7	7,5	30,8	20,2	8,2	29,3	19,6	9,2	27,6	18,9	10,5
			33	34,5	25,9	6,5	33,5	25,5	6,9	32,3	25,0	7,5	31,0	24,5	8,2	29,4	23,8	9,2	27,7	22,9	10,5

**HEATING CAPACITIES**

ASH+CIH 030S			Air inlet temperature at condenser (dry bulb)													
Airflow m³/h	Indoor dry bulb °C	-10 °C		-5 °C		0 °C		5 °C		7 °C		10 °C		15 °C		
		NH	AC	NH	AC	NH	AC	NH	AC	NH	AC	NH	AC	NH	AC	
Minimum	4650	15	18,4	5,37	21,4	5,96	24,3	6,54	27,1	7,11	28,3	7,34	29,9	7,69	32,7	8,30
		18	18,4	5,83	21,3	6,43	24,1	7,03	26,9	7,62	28,0	7,86	29,6	8,23	32,3	8,88
		20	18,4	6,16	21,3	6,77	24,0	7,38	26,8	7,99	27,9	8,24	29,4	8,62	32,1	9,30
		23	18,4	6,69	21,2	7,32	23,9	7,94	26,6	8,58	27,7	8,85	29,2	9,26	31,8	9,98
		25	18,5	7,08	21,2	7,71	23,9	8,35	26,5	9,01	27,5	9,29	29,1	9,72	31,6	10,48
		27	18,5	7,48	21,2	8,12	23,8	8,78	26,4	9,47	27,4	9,75	28,9	10,20	31,4	11,01
Nominal	5450	15	18,8	5,33	21,8	5,88	24,8	6,41	27,7	6,93	28,9	7,14	30,6	7,46	33,5	8,00
		19	18,8	5,96	21,7	6,51	24,6	7,05	27,5	7,60	28,6	7,82	30,2	8,16	33,0	8,74
		20	18,8	6,13	21,7	6,68	24,6	7,23	27,4	7,78	28,5	8,00	30,1	8,34	32,9	8,94
		23	18,8	6,67	21,6	7,22	24,4	7,78	27,2	8,35	28,3	8,58	29,9	8,94	32,5	9,58
		25	18,8	7,05	21,6	7,61	24,4	8,18	27,1	8,76	28,1	9,00	29,7	9,38	32,3	10,04
		27	18,8	7,46	21,6	8,02	24,3	8,59	26,9	9,19	28,0	9,44	29,6	9,83	32,1	10,53
Maximum	6000	15	18,9	5,12	21,9	5,65	24,9	6,15	27,9	6,64	29,1	6,83	30,9	7,13	33,8	7,64
		19	18,8	5,73	21,8	6,26	24,7	6,76	27,6	7,27	28,8	7,48	30,5	7,79	33,3	8,33
		20	18,8	5,90	21,8	6,42	24,7	6,93	27,6	7,44	28,7	7,65	30,4	7,97	33,2	8,52
		23	18,8	6,42	21,7	6,94	24,6	7,45	27,4	7,98	28,5	8,19	30,1	8,53	32,8	9,11
		25	18,8	6,79	21,7	7,31	24,5	7,83	27,2	8,36	28,3	8,59	29,9	8,93	32,6	9,53
		27	18,8	7,18	21,6	7,70	24,4	8,22	27,1	8,77	28,2	9,00	29,8	9,35	32,4	9,98

<b>Indoor fan power input (kw)</b>			
Minimum airflow	0,68	Nominal airflow	0,86
Maximum airflow	1		
<b>Outdoor fan power input (kw)</b>			
Nominal airflow	0,8		

<b>GC (kW)</b> :	Gross cooling capacity	<b>NH (kW)</b> :	Net heating capacity	<b>SC (kW)</b> :	Sensible cooling capacity	<b>AC (kW)</b> :	Compressor absorbed power
------------------	------------------------	------------------	----------------------	------------------	---------------------------	------------------	---------------------------

**COOLING CAPACITIES**

ASC/ASH + CIC/CIH 035S			Air inlet temperature at condenser (dry bulb)																		
Airflow m³/h	Indoor wet bulb °C	Indoor dry bulb °C	20 °C			25 °C			30 °C			35 °C			40 °C			45 °C			
			GC	SC	AC	GC	SC	AC	GC	SC	AC	GC	SC	AC	GC	SC	AC	GC	SC	AC	
Minimum	6200	16	21	36,6	22,8	7,7	35,7	22,3	8,2	34,6	21,8	8,8	33,2	21,3	9,7	31,7	20,6	10,8	29,9	19,8	12,5
			24	36,6	27,8	7,7	35,7	27,4	8,2	34,6	26,9	8,9	33,3	26,2	9,7	31,8	25,4	10,8	30,0	24,5	12,5
			27	36,6	32,8	7,7	35,7	32,4	8,2	34,6	31,8	8,9	33,3	31,1	9,7	31,8	30,2	10,9	30,0	29,1	12,5
		19	24	39,8	22,3	7,9	38,8	21,9	8,4	37,6	21,4	9,1	36,1	20,9	9,9	34,5	20,2	11,1	32,6	19,5	12,8
			27	39,9	27,3	7,9	38,9	26,9	8,4	37,7	26,4	9,1	36,2	25,8	10,0	34,6	25,1	11,1	32,7	24,2	12,8
			30	39,9	32,3	7,9	38,9	31,9	8,4	37,7	31,4	9,1	36,2	30,7	10,0	34,6	29,9	11,1	32,8	28,9	12,8
		22	27	43,3	21,8	8,1	42,1	21,4	8,7	40,8	20,9	9,3	39,3	20,4	10,2	37,5	19,8	11,4	35,5	19,2	13,1
			30	43,4	26,7	8,1	42,2	26,3	8,7	40,9	25,9	9,4	39,4	25,3	10,2	37,6	24,6	11,4	35,6	23,9	13,1
			33	43,4	31,6	8,1	42,3	31,2	8,7	41,0	30,7	9,4	39,4	30,1	10,2	37,7	29,4	11,4	35,7	28,5	13,1
Nominal	7100	16	21	36,9	23,2	8,1	36,0	22,8	8,7	34,8	22,3	9,4	33,5	21,7	10,3	31,9	21,0	11,6	30,1	20,2	13,5
			24	37,0	28,7	8,1	36,0	28,2	8,7	34,9	27,7	9,4	33,5	27,0	10,4	32,0	26,2	11,7	30,2	25,2	13,6
			27	37,0	34,0	8,1	36,1	33,6	8,7	34,9	33,0	9,4	33,6	32,2	10,4	32,3	31,3	11,5	30,7	29,7	13,4
		19	24	40,2	22,8	8,3	39,1	22,3	8,9	37,9	21,8	9,6	36,4	21,3	10,6	34,7	20,6	11,9	32,8	19,9	13,8
			27	40,3	28,2	8,3	39,2	27,8	8,9	38,0	27,2	9,6	36,5	26,6	10,6	34,8	25,8	11,9	32,9	24,9	13,8
			30	40,3	33,5	8,3	39,3	33,1	8,9	38,0	32,5	9,7	36,5	31,8	10,6	34,9	31,0	11,9	33,0	29,9	13,9
		22	27	43,7	22,2	8,5	42,5	21,8	9,1	41,1	21,3	9,9	39,6	20,8	10,9	37,8	20,2	12,2	35,8	19,6	14,1
			30	43,8	27,6	8,5	42,6	27,2	9,1	41,3	26,7	9,9	39,7	26,1	10,9	37,9	25,4	12,2	35,9	24,6	14,1
			33	43,8	32,9	8,6	42,7	32,5	9,2	41,3	32,0	9,9	39,7	31,3	10,9	38,0	30,5	12,2	36,0	29,6	14,1
Maximum	8050	16	21	37,6	23,8	7,9	36,6	23,4	8,4	35,4	22,9	9,1	34,0	22,3	9,9	32,4	21,6	11,1	30,6	20,8	12,7
			24	37,7	29,7	7,9	36,7	29,3	8,5	35,5	28,7	9,1	34,1	28,0	10,0	32,5	27,1	11,1	30,7	26,1	12,8
			27	37,7	35,5	7,9	36,7	35,0	8,5	35,8	34,6	9,1	34,5	33,3	10,0	33,1	31,9	11,2	31,5	30,3	12,9
		19	24	40,9	23,3	8,1	39,8	22,9	8,7	38,5	22,4	9,3	37,0	21,8	10,2	35,3	21,2	11,4	33,3	20,4	13,1
			27	41,0	29,2	8,1	39,9	28,8	8,7	38,6	28,2	9,4	37,1	27,6	10,2	35,4	26,8	11,4	33,5	25,8	13,1
			30	41,0	35,0	8,2	40,0	34,6	8,7	38,7	34,0	9,4	37,2	33,2	10,2	35,5	32,3	11,4	33,5	31,2	13,1
		22	27	44,4	22,7	8,4	43,2	22,2	8,9	41,8	21,8	9,6	40,2	21,3	10,5	38,4	20,7	11,7	36,3	20,0	13,4
			30	44,6	28,5	8,4	43,4	28,1	8,9	42,0	27,6	9,6	40,3	27,0	10,5	38,5	26,3	11,7	36,5	25,5	13,4
			33	44,6	34,3	8,4	43,4	33,9	8,9	42,0	33,4	9,6	40,4	32,7	10,5	38,6	31,9	11,7	36,6	30,9	13,4

**HEATING CAPACITIES**

ASH+CIH 035S		Air inlet temperature at condenser (dry bulb)														
Airflow m³/h	Indoor dry bulb °C	-10 °C		-5 °C		0 °C		5 °C		7 °C		10 °C		15 °C		
		NH	AC	NH	AC	NH	AC	NH	AC	NH	AC	NH	AC	NH	AC	
Minimum	6200	15	23,6	6,97	27,3	7,74	30,9	8,49	34,6	9,24	36,0	9,54	38,1	9,99	41,7	10,8
		18	23,5	7,45	27,2	8,26	30,8	9,05	34,3	9,84	35,7	10,2	37,8	10,6	41,3	11,5
		20	23,5	7,78	27,1	8,62	30,7	9,43	34,2	10,3	35,6	10,6	37,6	11,1	41,1	12,0
		23	23,48	8,31	27,0	9,18	30,5	10,0	33,9	10,9	35,3	11,3	37,3	11,8	40,7	12,8
		25	23,4	8,67	26,9	9,57	30,4	10,5	33,8	11,4	35,1	11,8	37,1	12,4	40,5	13,4
		27	23,4	9,04	26,9	9,98	30,3	10,9	33,6	11,9	35,0	12,3	36,9	12,9	40,2	14,0
Nominal	7100	15	23,8	6,72	27,6	7,44	31,3	8,13	35,0	8,81	36,4	9,08	38,6	9,5	42,2	10,2
		19	23,8	7,35	27,4	8,11	31,1	8,84	34,7	9,57	36,1	9,86	38,2	10,3	41,7	11,1
		20	23,7	7,51	27,4	8,28	31,0	9,02	34,6	9,77	36,0	10,1	38,1	10,5	41,6	11,3
		23	23,7	8,02	27,3	8,82	30,8	9,60	34,3	10,4	35,7	10,7	37,8	11,2	41,2	12,0
		25	23,7	8,37	27,2	9,19	30,7	10,0	34,2	10,8	35,6	11,2	37,6	11,7	41,0	12,6
		27	23,6	8,72	27,1	9,58	30,6	10,4	34,0	11,3	35,4	11,6	37,4	12,2	40,7	13,2
Maximum	8050	15	24,1	6,71	28,0	7,37	31,8	8,01	35,5	8,63	37,0	8,87	39,2	9,2	42,9	9,88
		19	24,1	7,36	27,8	8,05	31,5	8,72	35,2	9,38	36,6	9,64	38,8	10,0	42,4	10,7
		20	24,1	7,52	27,8	8,22	31,5	8,90	35,1	9,57	36,5	9,85	38,7	10,3	42,3	11,0
		23	24,0	8,05	27,7	8,77	31,3	9,48	34,9	10,2	36,3	10,5	38,4	10,9	41,9	11,7
		25	23,9	8,41	27,6	9,15	31,2	9,89	34,7	10,6	36,1	10,9	38,2	11,4	41,6	12,2
		27	23,9	8,78	27,5	9,55	31,1	10,3	34,5	11,1	35,9	11,4	38,0	11,9	41,4	12,7

<b>Indoor fan power input (kw)</b>			
Minimum airflow	0,82	Nominal airflow	0,99
Maximum airflow			1,20
<b>Outdoor fan power input (kw)</b>			
Nominal airflow	0,82		

<b>GC (kW)</b> :	Gross cooling capacity	<b>NH (kW)</b> :	Net heating capacity	<b>SC (kW)</b> :	Sensible cooling capacity	<b>AC (kW)</b> :	Compressor absorbed power
------------------	------------------------	------------------	----------------------	------------------	---------------------------	------------------	---------------------------

**COOLING CAPACITIES**

ASC/ASH + CIC/CIH 040S			Air inlet temperature at condenser (dry bulb)																		
Airflow m³/h	Indoor wet bulb °C	Indoor dry bulb °C	20 °C			25 °C			30 °C			35 °C			40 °C			45 °C			
			GC	SC	AC	GC	SC	AC	GC	SC	AC	GC	SC	AC	GC	SC	AC	GC	SC	AC	
Minimum	6950	16	21	41,9	25,6	9,1	40,9	25,0	9,7	39,5	24,4	10,5	38,0	23,7	11,5	36,1	22,8	12,8	34,0	21,8	14,8
			24	42,1	31,0	9,1	41,1	30,5	9,7	39,7	29,8	10,5	38,1	29,0	11,5	36,3	28,0	12,9	34,1	26,9	14,9
			27	42,2	36,4	9,1	41,2	35,9	9,7	39,8	35,2	10,5	38,2	34,4	11,5	36,4	33,2	12,9	34,3	31,9	14,9
		19	24	45,6	25,1	9,3	44,4	24,5	10,0	42,9	23,9	10,8	41,2	23,2	11,8	39,2	22,4	13,1	36,9	21,5	15,1
			27	45,8	30,4	9,4	44,6	29,9	10,0	43,1	29,3	10,8	41,4	28,5	11,8	39,4	27,6	13,2	37,2	26,5	15,2
			30	45,9	35,8	9,4	44,7	35,3	10,0	43,3	34,6	10,8	41,6	33,8	11,8	39,6	32,8	13,2	37,3	31,6	15,2
		22	27	49,5	24,5	9,6	48,2	23,9	10,3	46,6	23,3	11,1	44,7	22,7	12,1	42,6	21,9	13,5	40,2	21,1	15,5
			30	49,8	29,7	9,6	48,4	29,2	10,3	46,8	28,6	11,1	45,0	27,9	12,1	42,8	27,1	13,5	40,4	26,1	15,5
			33	49,9	34,9	9,6	48,6	34,5	10,3	47,0	33,9	11,1	45,1	33,1	12,1	43,0	32,2	13,5	40,6	31,1	15,6
Nominal	8150	16	21	42,6	26,0	9,6	41,4	25,5	10,3	40,0	24,9	11,1	38,4	24,1	12,2	36,4	23,2	13,6	34,2	22,2	15,8
			24	42,8	32,1	9,7	41,6	31,6	10,3	40,2	30,9	11,1	38,6	30,0	12,2	36,6	29,0	13,7	34,4	27,8	15,8
			27	42,9	38,2	9,7	41,8	37,6	10,3	40,4	36,9	11,1	38,7	36,0	12,2	36,8	34,8	13,7	34,7	33,3	15,9
		19	24	46,3	25,4	9,9	45,0	24,9	10,5	43,5	24,3	11,4	41,7	23,6	12,5	39,6	22,8	13,9	37,3	21,9	16,1
			27	46,5	31,5	9,9	45,2	31,0	10,6	43,7	30,3	11,4	41,9	29,5	12,5	39,9	28,6	14,0	37,5	27,4	16,2
			30	46,7	37,6	9,9	45,4	37,0	10,6	43,9	36,3	11,4	42,1	35,4	12,5	40,0	34,3	14,0	37,7	33,0	16,2
		22	27	50,3	24,8	10,1	48,9	24,2	10,8	47,2	23,6	11,7	45,3	23,0	12,8	43,1	22,3	14,3	40,6	21,4	16,5
			30	50,5	30,8	10,2	49,1	30,2	10,9	47,5	29,6	11,7	45,5	28,9	12,8	43,3	28,0	14,3	40,9	27,0	16,6
			33	50,7	36,7	10,2	49,3	36,2	10,9	47,7	35,6	11,7	45,7	34,8	12,8	43,5	33,8	14,4	41,1	32,6	16,6
Maximum	9050	16	21	43,3	26,8	9,7	42,2	26,2	10,3	40,7	25,6	11,0	39,0	24,8	12,0	37,0	23,9	13,4	34,7	22,9	15,4
			24	43,6	33,4	9,7	42,4	32,8	10,3	40,9	32,1	11,1	39,2	31,2	12,1	37,2	30,1	13,4	35,0	28,8	15,4
			27	43,7	40,0	9,7	42,6	39,4	10,3	41,1	38,7	11,1	39,4	37,7	12,7	37,5	36,3	13,5	35,2	34,8	15,5
		19	24	47,1	26,1	9,9	45,8	25,6	10,6	44,2	25,0	11,3	42,4	24,3	12,4	40,2	23,4	13,8	37,8	22,5	15,8
			27	47,4	32,8	9,9	46,0	32,2	10,6	44,5	31,5	11,4	42,6	30,7	12,4	40,5	29,7	13,8	38,1	28,5	15,8
			30	47,5	39,4	10,0	46,2	38,8	10,6	44,6	38,1	11,4	42,8	37,1	12,4	40,7	36,0	13,8	38,3	34,6	15,9
		22	27	51,2	25,4	10,2	49,7	24,9	10,9	48,0	24,3	11,7	46,0	23,6	12,7	43,7	22,9	14,2	41,2	22,0	16,2
			30	51,4	32,0	10,2	50,0	31,4	10,9	48,3	30,8	11,7	46,3	30,1	12,7	44,0	29,2	14,2	41,5	28,1	16,3
			33	51,6	38,6	10,2	50,2	38,0	10,9	48,5	37,4	11,7	46,5	36,5	12,8	44,2	35,5	14,2	41,7	34,2	16,3

**HEATING CAPACITIES**

ASH+CIH 040S			Air inlet temperature at condenser (dry bulb)													
Airflow m³/h	Indoor dry bulb °C	-10 °C		-5 °C		0 °C		5 °C		7 °C		10 °C		15 °C		
		NH	AC	NH	AC	NH	AC	NH	AC	NH	AC	NH	AC	NH	AC	
Minimum	6950	15	25,8	7,34	29,8	8,18	33,9	8,99	37,9	9,79	39,5	10,1	41,9	10,6	45,8	11,4
		18	25,7	7,85	29,7	8,73	33,7	9,58	37,7	10,4	39,2	10,8	41,6	11,3	45,5	12,2
		20	25,7	8,21	29,7	9,12	33,6	10,0	37,5	10,9	39,1	11,2	41,4	11,8	45,3	12,7
		23	25,7	8,77	29,6	9,72	33,5	10,7	37,3	11,6	38,9	12,0	41,2	12,6	45,0	13,6
		25	25,7	9,16	29,6	10,1	33,4	11,1	37,2	12,1	38,7	12,5	41,0	13,2	44,8	14,2
		27	25,7	9,55	29,5	10,6	33,3	11,6	37,1	12,6	38,6	13,1	40,8	13,7	44,6	14,9
Nominal	8150	15	26,5	7,46	30,6	8,23	34,7	8,96	38,8	9,69	40,4	9,98	42,8	10,4	46,8	11,2
		19	26,4	8,17	30,5	8,98	34,5	9,76	38,5	10,5	40,1	10,9	42,5	11,3	46,4	12,2
		20	26,4	8,35	30,4	9,17	34,4	9,97	38,4	10,8	40,0	11,1	42,4	11,6	46,3	12,4
		23	26,4	8,92	30,4	9,78	34,3	10,6	38,2	11,5	39,8	11,8	42,1	12,3	46,0	13,3
		25	26,4	9,32	30,3	10,2	34,2	11,1	38,1	12,0	39,6	12,3	41,9	12,9	45,8	13,8
		27	26,4	9,72	30,3	10,6	34,1	11,5	38,0	12,5	39,5	12,9	41,8	13,4	45,6	14,5
Maximum	9050	15	26,7	7,35	30,9	8,07	35,0	8,75	39,2	9,43	40,8	9,70	43,3	10,1	47,4	10,8
		19	26,7	8,05	30,8	8,80	34,8	9,53	38,9	10,2	40,5	10,5	42,9	11,0	46,9	11,7
		20	26,7	8,24	30,7	9,00	34,8	9,73	38,8	10,5	40,4	10,8	42,8	11,2	46,8	12,0
		23	26,7	8,80	30,7	9,59	34,7	10,4	38,6	11,1	40,2	11,5	42,6	11,9	46,5	12,8
		25	26,6	9,18	30,6	9,99	34,6	10,8	38,5	11,6	40,1	11,9	42,4	12,4	46,3	13,3
		27	26,6	9,57	30,6	10,4	34,5	11,2	38,4	12,1	39,9	12,4	42,2	13,0	46,1	13,9

<b>Indoor fan power input (kw)</b>			
Minimum airflow	1,12	Nominal airflow	1,42
Maximum airflow			1,67
<b>Outdoor fan power input (kw)</b>			
Nominal airflow	0,82		

<b>GC (kW)</b> :	Gross cooling capacity	<b>NH (kW)</b> :	Net heating capacity	<b>SC (kW)</b> :	Sensible cooling capacity	<b>AC (kW)</b> :	Compressor absorbed power
------------------	------------------------	------------------	----------------------	------------------	---------------------------	------------------	---------------------------

**COOLING CAPACITIES**

ASC/ASH + CIC/CIH 045D			Air inlet temperature at condenser (dry bulb)																		
Airflow m³/h	Indoor wet bulb °C	Indoor dry bulb °C	20 °C			25 °C			30 °C			35 °C			40 °C			45 °C			
			GC	SC	AC	GC	SC	AC	GC	SC	AC	GC	SC	AC	GC	SC	AC	GC	SC	AC	
Minimum	7950	16	21	48,4	29,1	9,5	47,2	28,5	10,2	45,7	27,8	11,1	43,9	27,0	12,3	41,9	26,0	13,8	39,7	25,0	15,9
			24	48,6	35,2	9,5	47,4	34,6	10,2	45,9	33,8	11,1	44,1	33,0	12,3	42,2	31,9	13,8	39,9	30,7	15,9
			27	48,7	41,2	9,5	47,5	40,6	10,2	46,0	39,9	11,2	44,3	38,9	12,3	42,3	37,8	13,8	40,1	36,4	15,9
		19	24	52,7	28,6	9,7	51,3	28,0	10,5	49,7	27,3	11,4	47,8	26,5	12,6	45,6	25,6	14,1	43,2	24,6	16,2
			27	52,9	34,6	9,7	51,5	34,0	10,5	49,9	33,3	11,4	48,0	32,4	12,6	45,9	31,5	14,1	43,5	30,4	16,3
			30	53,1	40,6	9,8	51,7	40,0	10,5	50,1	39,3	11,5	48,2	38,4	12,6	46,0	37,3	14,1	43,7	36,0	16,3
		22	27	57,3	28,0	10,1	55,8	27,3	10,8	54,0	26,7	11,8	51,9	25,9	13,0	49,6	25,1	14,5	47,1	24,2	16,7
			30	57,5	33,8	10,1	56,0	33,2	10,9	54,2	32,5	11,8	52,2	31,8	13,0	49,9	30,9	14,5	47,4	29,9	16,7
			33	57,7	39,7	10,1	56,2	39,1	10,9	54,4	38,4	11,8	52,4	37,6	13,0	50,1	36,7	14,6	47,6	35,5	16,7
Nominal	9400	16	21	49,2	29,6	10,2	47,9	28,9	11,0	46,3	28,2	12,0	44,5	27,4	13,2	42,4	26,5	14,8	40,1	25,4	17,0
			24	49,4	36,4	10,2	48,1	35,8	11,0	46,6	35,0	12,0	44,7	34,1	13,2	42,7	33,0	14,8	40,4	31,7	17,0
			27	49,6	43,2	10,2	48,3	42,6	11,0	46,7	41,7	12,0	44,9	40,7	13,2	42,8	39,5	14,8	40,5	38,0	17,1
		19	24	53,6	29,0	10,5	52,1	28,3	11,3	50,4	27,6	12,3	48,4	26,9	13,5	46,2	26,0	15,1	43,7	25,0	17,4
			27	53,8	35,8	10,5	52,4	35,1	11,3	50,6	34,4	12,3	48,7	33,5	13,5	46,5	32,5	15,1	44,0	31,3	17,4
			30	54,0	42,6	10,5	52,5	42,0	11,3	50,8	41,2	12,3	48,9	40,2	13,5	46,7	39,1	15,2	44,2	37,7	17,5
		22	27	58,2	28,2	10,8	56,6	27,6	11,6	54,7	26,9	12,6	52,6	26,2	13,9	50,2	25,4	15,6	47,6	24,5	17,9
			30	58,5	35,0	10,8	56,9	34,3	11,7	55,0	33,6	12,7	52,9	32,8	13,9	50,5	31,9	15,6	47,9	30,9	18,0
			33	58,7	41,7	10,8	57,1	41,1	11,7	55,2	40,4	12,7	53,1	39,5	14,0	50,8	38,5	15,6	48,1	37,2	18,0
Maximum	9750	16	21	49,5	29,7	10,3	48,1	29,1	11,1	46,5	28,4	12,0	44,7	27,6	13,2	42,6	26,6	14,8	40,2	25,5	17,0
			24	49,7	36,8	10,3	48,4	36,1	11,1	46,8	35,3	12,0	44,9	34,4	13,2	42,8	33,3	14,8	40,5	32,0	17,0
			27	49,9	43,8	10,3	48,5	43,1	11,1	46,9	42,3	12,0	45,1	41,2	13,2	43,0	39,9	14,8	40,7	38,4	17,0
		19	24	53,8	29,1	10,6	52,3	28,5	11,4	50,6	27,8	12,3	48,6	27,0	13,5	46,4	26,1	15,1	43,9	25,1	17,4
			27	54,1	36,1	10,6	52,6	35,5	11,4	50,9	34,8	12,3	48,9	33,9	13,6	46,6	32,8	15,2	44,2	31,6	17,4
			30	54,3	43,2	10,6	52,8	42,5	11,4	51,1	41,7	12,4	49,1	40,7	13,6	46,8	39,6	15,2	44,4	38,2	17,4
		22	27	58,5	28,3	10,9	56,9	27,7	11,7	55,0	27,1	12,7	52,8	26,3	14,0	50,4	25,5	15,6	47,8	24,6	17,9
			30	58,8	35,3	10,9	57,1	34,7	11,7	55,3	34,0	12,7	53,1	33,2	14,0	50,7	32,2	15,6	48,1	31,2	18,0
			33	59,0	42,2	10,9	57,4	41,6	11,8	55,5	40,9	12,8	53,3	40,0	14,0	51,0	39,0	15,7	48,3	37,7	18,0

**HEATING CAPACITIES**

ASH+CIH 045D		Air inlet temperature at condenser (dry bulb)														
Airflow m³/h	Indoor dry bulb °C	-10 °C		-5 °C		0 °C		5 °C		7 °C		10 °C		15 °C		
		NH	AC	NH	AC	NH	AC	NH	AC	NH	AC	NH	AC	NH	AC	
Minimum	7950	15	31,7	8,84	36,8	9,89	41,8	10,9	46,7	12,0	48,6	12,4	51,5	13,1	56,2	14,2
		18	31,7	9,62	36,7	10,7	41,5	11,8	46,3	12,9	48,2	13,3	51,1	14,0	55,7	15,3
		20	31,7	10,2	36,6	11,3	41,4	12,4	46,1	13,5	48,0	14,0	50,8	14,7	55,3	16,1
		23	31,7	11,1	36,5	12,2	41,2	13,4	45,8	14,6	47,6	15,1	50,4	15,9	54,8	17,4
		25	31,7	11,8	36,4	12,9	41,1	14,1	45,6	15,4	47,4	15,9	50,1	16,8	54,5	18,3
		27	31,7	12,5	36,4	13,7	40,9	14,9	45,4	16,3	47,2	16,8	49,8	17,7	54,1	19,4
Nominal	9400	15	32,8	8,89	38,0	9,82	43,2	10,7	48,2	11,7	50,2	12,1	53,1	12,6	58,0	13,7
		19	32,8	9,94	37,8	10,9	42,8	11,8	47,7	12,8	49,6	13,2	52,5	13,9	57,2	15,0
		20	32,8	10,2	37,8	11,2	42,7	12,1	47,6	13,1	49,5	13,5	52,3	14,2	57,0	15,3
		23	32,7	11,1	37,7	12,1	42,5	13,1	47,2	14,1	49,1	14,6	51,9	15,3	56,5	16,5
		25	32,7	11,8	37,6	12,8	42,3	13,8	47,0	14,9	48,9	15,3	51,6	16,0	56,1	17,4
		27	32,7	12,5	37,5	13,5	42,2	14,5	46,8	15,7	48,6	16,1	51,3	16,9	55,8	18,3
Maximum	9750	15	33,0	8,86	38,2	9,76	43,4	10,7	48,5	11,6	50,5	11,9	53,4	12,5	58,3	13,5
		19	32,9	9,90	38,0	10,8	43,0	11,7	48,0	12,7	49,9	13,1	52,8	13,7	57,5	14,8
		20	32,9	10,2	38,0	11,1	43,0	12,0	47,8	13,0	49,8	13,4	52,6	14,0	57,3	15,1
		23	32,9	11,1	37,8	12,0	42,7	13,0	47,5	14,0	49,4	14,4	52,2	15,1	56,8	16,3
		25	32,9	11,8	37,8	12,7	42,6	13,7	47,3	14,7	49,1	15,1	51,9	15,8	56,4	17,1
		27	32,9	12,5	37,7	13,4	42,4	14,4	47,1	15,5	48,9	15,9	51,6	16,6	56,1	18,0

<b>Indoor fan power input (kw)</b>			
Minimum airflow	1,7	Nominal airflow	2,18
Maximum airflow	2,3		
<b>Outdoor fan power input (kw)</b>			
Nominal airflow	1,34		

<b>GC (kW)</b> :	Gross cooling capacity	<b>NH (kW)</b> :	Net heating capacity	<b>SC (kW)</b> :	Sensible cooling capacity	<b>AC (kW)</b> :	Compressor absorbed power
------------------	------------------------	------------------	----------------------	------------------	---------------------------	------------------	---------------------------



**COOLING CAPACITIES**

ASC/ASH + CIC/CIH 055D			Air inlet temperature at condenser (dry bulb)																		
Airflow m³/h	Indoor wet bulb °C	Indoor dry bulb °C	20 °C			25 °C			30 °C			35 °C			40 °C			45 °C			
			GC	SC	AC	GC	SC	AC	GC	SC	AC	GC	SC	AC	GC	SC	AC	GC	SC	AC	
Minimum	9950	16	21	57,3	35,0	12,0	55,7	34,2	13,0	53,7	33,3	14,1	51,3	32,2	15,6	48,6	31,0	17,6	45,5	29,5	20,4
			24	57,6	42,7	12,1	56,0	41,9	13,0	54,0	40,9	14,2	51,6	39,7	15,6	48,9	38,3	17,6	45,8	36,6	20,4
			27	57,8	50,3	12,1	56,2	49,5	13,0	54,2	48,5	14,2	51,8	47,2	15,7	49,1	45,5	17,6	46,0	43,6	20,5
		19	24	62,3	34,3	12,4	60,5	33,5	13,3	58,3	32,6	14,5	55,7	31,6	16,0	52,8	30,4	18,0	49,6	29,1	20,8
			27	62,6	41,9	12,4	60,8	41,1	13,4	58,7	40,2	14,5	56,1	39,1	16,0	53,2	37,8	18,0	50,0	36,2	20,9
			30	62,9	49,4	12,4	61,1	48,7	13,4	58,9	47,7	14,6	56,4	46,5	16,1	53,5	45,0	18,0	50,2	43,2	20,9
		22	27	67,6	33,5	12,7	65,6	32,7	13,7	63,3	31,8	14,9	60,6	30,9	16,4	57,5	29,8	18,4	54,1	28,6	21,3
			30	68,0	40,9	12,8	66,0	40,2	13,7	63,7	39,3	14,9	61,0	38,3	16,4	57,9	37,1	18,4	54,5	35,7	21,3
			33	68,3	48,3	12,8	66,3	47,6	13,8	64,0	46,7	14,9	61,3	45,6	16,5	58,2	44,3	18,5	54,8	42,7	21,4
Nominal	11700	16	21	58,6	36,3	12,4	56,9	35,5	13,4	54,8	34,6	14,5	52,3	33,5	16,0	49,5	32,2	18,0	46,3	30,7	21,0
			24	59,0	44,9	12,4	57,2	44,1	13,4	55,1	43,1	14,6	52,7	41,8	16,1	49,9	40,3	18,1	46,7	38,5	21,0
			27	59,2	53,5	12,4	57,5	52,6	13,4	55,4	51,5	14,6	52,9	50,1	16,1	50,1	48,4	18,1	47,0	45,2	21,0
		19	24	63,7	35,5	12,7	61,7	34,7	13,7	59,5	33,8	14,9	56,8	32,8	16,4	53,8	31,6	18,5	50,5	30,2	21,4
			27	64,0	44,1	12,8	62,1	43,3	13,7	59,9	42,3	14,9	57,3	41,2	16,5	54,3	39,8	18,5	50,9	38,1	21,5
			30	64,3	52,6	12,8	62,4	51,8	13,8	60,2	50,8	15,0	57,6	49,5	16,5	54,6	47,9	18,5	51,2	46,0	21,5
		22	27	69,1	34,6	13,1	67,0	33,8	14,1	64,6	32,9	15,3	61,8	32,0	16,8	58,6	30,9	18,9	55,1	29,7	21,9
			30	69,5	43,0	13,1	67,5	42,3	14,1	65,0	41,4	15,3	62,2	40,3	16,9	59,1	39,1	18,9	55,5	37,6	21,9
			33	69,8	51,5	13,1	67,8	50,8	14,1	65,3	49,8	15,3	62,6	48,7	16,9	59,4	47,3	19,0	55,9	45,6	22,0
Maximum	12850	16	21	59,5	37,3	12,3	57,7	36,5	13,3	55,6	35,5	14,4	53,0	34,4	15,9	50,2	33,1	17,8	46,9	31,5	20,6
			24	59,9	46,5	12,4	58,1	45,7	13,3	56,0	44,6	14,5	53,5	43,3	15,9	50,6	41,7	17,8	47,4	39,8	20,6
			27	60,2	55,7	12,4	58,4	54,9	13,3	56,3	53,7	14,5	53,8	51,8	15,9	50,9	48,9	17,9	47,7	48,1	20,7
		19	24	64,6	36,4	12,7	62,7	35,6	13,6	60,3	34,7	14,8	57,6	33,6	16,3	54,6	32,5	18,3	51,2	31,1	21,1
			27	65,1	45,7	12,7	63,1	44,8	13,7	60,8	43,8	14,8	58,1	42,6	16,3	55,1	41,2	18,3	51,6	39,5	21,1
			30	65,4	54,9	12,7	63,4	54,1	13,7	61,1	53,0	14,9	58,4	51,6	16,4	55,4	50,0	18,3	52,0	47,9	21,2
		22	27	70,1	35,3	13,0	68,0	34,6	14,0	65,5	33,7	15,2	62,6	32,8	16,7	59,4	31,7	18,7	55,8	30,5	21,6
			30	70,6	44,6	13,1	68,5	43,8	14,1	66,0	42,9	15,2	63,1	41,8	16,8	59,9	40,5	18,8	56,3	39,0	21,6
			33	70,9	53,8	13,1	68,8	53,0	14,1	66,3	52,0	15,3	63,5	50,8	16,8	60,3	49,3	18,8	56,7	47,5	21,7

**HEATING CAPACITIES**

ASH+CIH 055D			Air inlet temperature at condenser (dry bulb)													
Airflow m³/h	Indoor dry bulb °C	-10 °C		-5 °C		0 °C		5 °C		7 °C		10 °C		15 °C		
		NH	AC	NH	AC	NH	AC	NH	AC	NH	AC	NH	AC	NH	AC	
Minimum	9950	15	36,6	10,6	42,5	11,8	48,3	12,9	54,0	14,0	56,3	14,5	59,7	15,2	65,2	16,4
		18	36,6	11,6	42,3	12,7	48,0	13,9	53,6	15,1	55,8	15,5	59,1	16,3	64,5	17,5
		20	36,6	12,2	42,3	13,4	47,8	14,6	53,3	15,8	55,5	16,3	58,7	17,1	64,0	18,4
		23	36,6	13,3	42,1	14,6	47,6	15,8	52,9	17,0	55,1	17,5	58,2	18,3	63,4	19,8
		25	36,6	14,1	42,1	15,4	47,4	16,6	52,7	17,9	54,8	18,4	57,9	19,3	63,0	20,8
		27	n/a	n/a	42,0	16,2	47,3	17,5	52,5	18,8	54,5	19,4	57,6	20,3	62,6	21,9
Nominal	11700	15	37,1	10,3	43,2	11,3	49,1	12,3	55,0	13,4	57,3	13,8	60,8	14,4	66,5	15,4
		19	37,1	11,5	42,9	12,6	48,7	13,6	54,4	14,7	56,7	15,1	60,0	15,8	65,5	16,9
		20	37,1	11,8	42,9	12,9	48,6	14,0	54,3	15,0	56,5	15,5	59,8	16,1	65,3	17,3
		23	37,1	12,9	42,7	14,0	48,3	15,1	53,9	16,2	56,0	16,6	59,3	17,3	64,6	18,6
		25	37,1	13,7	42,7	14,8	48,2	15,9	53,6	17,0	55,8	17,5	58,9	18,2	64,2	19,5
		27	37,1	14,5	42,6	15,6	48,0	16,7	53,4	17,9	55,5	18,3	58,6	19,1	63,8	20,5
Maximum	12850	15	37,2	9,9	43,3	10,9	49,4	11,9	55,4	12,8	57,8	13,2	61,3	13,8	67,1	14,8
		19	37,1	11,1	43,1	12,1	49,0	13,1	54,8	14,1	57,1	14,5	60,5	15,1	66,1	16,2
		20	37,1	11,5	43,0	12,5	48,9	13,5	54,6	14,4	56,9	14,8	60,3	15,5	65,9	16,5
		23	37,1	12,5	42,9	13,5	48,6	14,5	54,2	15,5	56,4	16,0	59,7	16,6	65,2	17,7
		25	37,1	13,3	42,8	14,3	48,4	15,3	53,9	16,3	56,1	16,7	59,4	17,4	64,7	18,6
		27	37,1	14,1	42,7	15,1	48,3	16,1	53,7	17,1	55,8	17,6	59,1	18,3	64,3	19,5

<b>Indoor fan power input (kw)</b>			
Minimum airflow	1,45	Nominal airflow	1,76
Maximum airflow			2,00
<b>Outdoor fan power input (kw)</b>			
Nominal airflow	1,6		

<b>GC (kW)</b> :	Gross cooling capacity	<b>NH (kW)</b> :	Net heating capacity	<b>SC (kW)</b> :	Sensible cooling capacity	<b>AC (kW)</b> :	Compressor absorbed power
------------------	------------------------	------------------	----------------------	------------------	---------------------------	------------------	---------------------------

**COOLING CAPACITIES**

ASC/ASH + CIC/CIH 070D			Air inlet temperature at condenser (dry bulb)																		
Airflow m³/h	Indoor wet bulb °C	Indoor dry bulb °C	20 °C			25 °C			30 °C			35 °C			40 °C			45 °C			
			GC	SC	AC	GC	SC	AC	GC	SC	AC	GC	SC	AC	GC	SC	AC	GC	SC	AC	
Minimum	12450	16	21	72,0	43,5	14,7	70,2	42,6	15,7	67,9	41,6	17,0	65,2	40,4	18,6	62,1	38,9	20,8	58,6	37,3	23,9
			24	72,4	53,1	14,7	70,6	52,2	15,8	68,3	51,1	17,1	65,7	49,7	18,7	62,6	48,1	20,9	59,0	46,1	24,0
			27	72,6	62,6	14,8	70,8	61,7	15,8	68,6	60,6	17,1	65,9	59,1	18,7	62,8	57,2	20,9	59,3	55,0	24,0
		19	24	78,2	42,6	15,1	76,2	41,7	16,2	73,7	40,7	17,5	70,8	39,5	19,1	67,5	38,2	21,3	63,7	36,6	24,5
			27	78,7	52,1	15,2	76,6	51,2	16,2	74,2	50,1	17,5	71,3	48,8	19,2	67,9	47,3	21,4	64,2	45,5	24,6
			30	79,0	61,5	15,2	76,9	60,6	16,3	74,5	59,5	17,6	71,6	58,2	19,2	68,2	56,5	21,4	64,5	54,4	24,6
		22	27	85,0	41,6	15,6	82,7	40,7	16,7	80,0	39,7	18,0	76,9	38,6	19,7	73,3	37,3	21,9	69,3	35,9	25,1
			30	85,5	50,9	15,6	83,2	50,0	16,7	80,5	49,0	18,0	77,4	47,8	19,7	73,8	46,4	22,0	69,8	44,8	25,2
			33	85,8	60,1	15,7	83,5	59,3	16,7	80,8	58,3	18,1	77,7	57,0	19,7	74,2	55,5	22,0	70,2	53,6	25,2
Nominal	14650	16	21	73,3	44,8	15,5	71,4	43,8	16,6	69,0	42,8	18,0	66,2	41,5	19,7	63,0	40,0	22,2	59,4	38,3	25,8
			24	73,7	55,2	15,5	71,8	54,3	16,6	69,5	53,1	18,0	66,7	51,7	19,8	63,5	50,0	22,2	59,9	47,9	25,8
			27	74,0	65,7	15,5	72,1	64,7	16,6	69,8	63,5	18,0	67,0	61,9	19,8	63,8	59,9	22,3	60,2	0,0	25,9
		19	24	79,6	43,8	15,9	77,5	42,9	17,0	74,9	41,8	18,4	71,9	40,6	20,2	68,4	39,3	22,7	64,6	37,7	26,3
			27	80,1	54,2	15,9	77,9	53,3	17,1	75,4	52,2	18,5	72,4	50,8	20,3	69,0	49,2	22,8	65,1	47,3	26,4
			30	80,4	64,6	16,0	78,3	63,7	17,1	75,7	62,5	18,5	72,7	61,1	20,3	69,3	59,2	22,8	65,4	57,0	26,4
		22	27	86,4	42,7	16,3	84,1	41,7	17,5	81,3	40,7	18,9	78,0	39,6	20,8	74,4	38,4	23,3	70,3	37,0	26,9
			30	87,0	53,0	16,4	84,6	52,1	17,5	81,8	51,0	19,0	78,6	49,8	20,8	74,9	48,3	23,3	70,8	46,6	26,9
			33	87,3	63,3	16,4	85,0	62,4	17,6	82,2	61,3	19,0	79,0	60,0	20,8	75,3	58,3	23,4	71,2	56,4	27,0
Maximum	15090	16	21	73,6	44,9	15,4	71,6	44,0	16,5	69,3	42,9	17,8	66,5	41,7	19,6	63,3	40,2	22,0	59,6	38,5	25,5
			24	74,0	55,6	15,4	72,1	54,7	16,5	69,7	53,5	17,9	66,9	52,0	19,7	63,7	50,3	22,0	60,1	48,2	25,5
			27	74,3	66,2	15,5	72,4	65,3	16,6	70,0	64,0	17,9	67,2	62,4	19,7	64,0	60,4	22,1	60,4	57,9	25,6
		19	24	79,9	43,9	15,8	77,7	43,0	16,9	75,2	42,0	18,3	72,1	40,8	20,1	68,7	39,4	22,5	64,8	37,8	26,1
			27	80,4	54,6	15,9	78,2	53,6	17,0	75,7	52,5	18,4	72,6	51,2	20,2	69,2	49,6	22,6	65,3	47,7	26,1
			30	80,7	65,2	15,9	78,6	64,3	17,0	76,0	63,1	18,4	73,0	61,6	20,2	69,6	59,7	22,6	65,7	57,5	26,2
		22	27	86,8	42,8	16,3	84,4	41,9	17,4	81,6	40,9	18,8	78,3	39,7	20,6	74,6	38,5	23,1	70,5	37,1	26,6
			30	87,3	53,3	16,3	84,9	52,4	17,4	82,1	51,3	18,9	78,9	50,1	20,7	75,2	48,7	23,1	71,1	47,0	26,7
			33	87,7	63,8	16,3	85,3	63,0	17,5	82,5	61,9	18,9	79,3	60,5	20,7	75,6	58,9	23,2	71,5	56,9	26,7

**HEATING CAPACITIES**

ASH+CIH 070D		Air inlet temperature at condenser (dry bulb)														
Airflow m³/h	Indoor dry bulb °C	-10 °C		-5 °C		0 °C		5 °C		7 °C		10 °C		15 °C		
		NH	AC	NH	AC	NH	AC	NH	AC	NH	AC	NH	AC	NH	AC	
Minimum	12450	15	47,1	13,1	54,4	14,6	61,6	16,1	68,8	17,6	71,6	18,2	75,8	19,0	82,8	20,6
		18	47,0	14,1	54,2	15,6	61,3	17,2	68,3	18,7	71,1	19,3	75,2	20,3	82,1	21,9
		20	46,9	14,7	54,0	16,3	61,0	17,9	68,0	19,5	70,7	20,2	74,8	21,2	81,6	22,9
		23	46,8	15,7	53,8	17,4	60,7	19,1	67,5	20,8	70,2	21,5	74,2	22,6	80,9	24,5
		25	46,8	16,4	53,6	18,1	60,5	19,9	67,2	21,7	69,9	22,5	73,8	23,6	80,4	25,6
		27	n/a	n/a	n/a	n/a	60,2	20,7	66,9	22,6	69,5	23,4	73,4	24,7	79,9	26,8
Nominal	14650	15	48,3	13,1	55,8	14,5	63,2	15,8	70,5	17,1	73,4	17,7	77,7	18,4	84,9	19,8
		19	48,2	14,4	55,5	15,9	62,7	17,3	69,8	18,7	72,7	19,2	76,9	20,1	83,9	21,6
		20	48,1	14,8	55,4	16,2	62,6	17,6	69,7	19,1	72,5	19,6	76,7	20,5	83,6	22,0
		23	48,0	15,8	55,2	17,3	62,2	18,8	69,2	20,3	72,0	21,0	76,1	21,9	82,9	23,5
		25	48,0	16,5	55,0	18,1	62,0	19,6	68,9	21,2	71,6	21,9	75,7	22,9	82,4	24,6
		27	47,9	17,2	54,9	18,9	61,8	20,5	68,6	22,1	71,3	22,8	75,3	23,9	81,9	25,7
Maximum	15090	15	48,3	13,0	55,8	14,3	63,3	15,6	70,6	16,9	73,5	17,4	77,9	18,2	85,0	19,5
		19	48,2	14,2	55,5	15,7	62,8	17,0	70,0	18,4	72,8	18,9	77,0	19,8	84,1	21,2
		20	48,2	14,6	55,5	16,0	62,7	17,4	69,8	18,8	72,6	19,3	76,8	20,2	83,8	21,7
		23	48,1	15,6	55,2	17,1	62,3	18,6	69,3	20,0	72,1	20,6	76,2	21,5	83,1	23,1
		25	48,0	16,3	55,1	17,8	62,1	19,4	69,0	20,9	71,7	21,5	75,8	22,5	82,6	24,2
		27	47,9	17,0	54,9	18,6	61,8	20,2	68,7	21,8	71,4	22,5	75,4	23,5	82,1	25,3

<b>Indoor fan power input (kw)</b>			
Minimum airflow	2,32	Nominal airflow	2,88
Maximum airflow	3		
<b>Outdoor fan power input (kw)</b>			
Nominal airflow	1,64		

<b>GC (kW)</b> :	Gross cooling capacity	<b>NH (kW)</b> :	Net heating capacity	<b>SC (kW)</b> :	Sensible cooling capacity	<b>AC (kW)</b> :	Compressor absorbed power
------------------	------------------------	------------------	----------------------	------------------	---------------------------	------------------	---------------------------

**COOLING CAPACITIES**

ASC/ASH + CIC/CIH 085D			Air inlet temperature at condenser (dry bulb)																		
Airflow m <sup>3</sup> /h	Indoor wet bulb °C	Indoor dry bulb °C	20 °C			25 °C			30 °C			35 °C			40 °C			45 °C			
			GC	SC	AC	GC	SC	AC	GC	SC	AC	GC	SC	AC	GC	SC	AC	GC	SC	AC	
Minimum	14000	16	21	86,4	52,2	17,4	84,2	51,1	18,6	81,3	49,7	20,1	77,8	48,2	22,1	73,8	46,3	24,7	69,2	44,2	28,6
			24	87,1	64,3	17,5	84,9	63,2	18,7	82,0	61,8	20,2	78,6	60,0	22,2	74,6	57,9	24,8	70,0	55,3	28,7
			27	87,4	76,1	17,5	85,1	75,0	18,7	82,3	73,6	20,3	78,9	71,6	22,2	74,9	69,2	24,9	70,4	66,3	28,8
		19	24	93,8	51,1	17,9	91,3	49,9	19,2	88,1	48,6	20,7	84,4	47,1	22,6	80,1	45,4	25,3	75,2	43,4	29,2
			27	94,6	63,1	18,0	92,1	62,0	19,2	88,9	60,6	20,8	85,2	59,0	22,7	80,9	57,0	25,4	76,1	54,6	29,3
			30	95,0	74,8	18,0	92,5	73,8	19,3	89,3	72,4	20,8	85,6	70,6	22,8	81,4	68,4	25,5	76,5	65,7	29,4
		22	27	101,7	49,8	18,5	98,8	48,6	19,7	95,4	47,3	21,3	91,4	45,9	23,3	86,8	44,3	26,0	81,6	42,5	29,9
			30	102,6	61,5	18,5	99,8	60,4	19,8	96,3	59,2	21,4	92,3	57,6	23,4	87,8	55,8	26,1	82,6	53,7	30,0
			33	103,1	73,1	18,6	100,3	72,1	19,8	96,9	70,8	21,4	92,9	69,2	23,4	88,3	67,2	26,2	83,2	64,8	30,1
Nominal	16250	16	21	87,3	53,1	18,4	85,0	52,0	19,7	82,0	50,6	21,4	78,4	49,0	23,5	74,3	47,1	26,6	69,6	44,9	31,1
			24	88,1	66,3	18,5	85,8	65,1	19,8	82,8	63,6	21,5	79,3	61,8	23,6	75,2	59,5	26,7	70,5	56,8	31,2
			27	88,5	79,1	18,5	86,1	78,0	19,8	83,2	76,4	21,5	79,7	74,4	23,7	75,6	71,6	26,7	71,0	67,0	31,3
		19	24	94,8	51,9	18,9	92,1	50,7	20,2	88,9	49,4	21,9	85,0	47,9	24,1	80,6	46,1	27,1	75,7	44,1	31,7
			27	95,7	65,0	19,0	93,1	63,9	20,3	89,8	62,5	22,0	86,0	60,8	24,2	81,6	58,7	27,2	76,6	56,2	31,8
			30	96,2	78,0	19,0	93,5	76,8	20,3	90,3	75,3	22,0	86,5	73,4	24,2	82,2	71,1	27,3	77,2	68,1	31,9
		22	27	102,8	50,5	19,4	99,8	49,3	20,8	96,2	48,0	22,5	92,1	46,6	24,7	87,4	45,0	27,8	82,1	43,2	32,4
			30	103,8	63,4	19,5	100,8	62,3	20,9	97,3	61,0	22,6	93,2	59,4	24,8	88,5	57,5	27,9	83,3	55,3	32,5
			33	104,4	76,3	19,5	101,4	75,2	20,9	97,9	73,8	22,6	93,8	72,1	24,9	89,2	70,0	28,0	84,0	67,4	32,6
Maximum	16725	16	21	87,7	53,3	18,4	85,2	52,2	19,7	82,2	50,8	21,3	78,7	49,2	23,4	74,5	47,3	26,4	69,8	45,0	30,9
			24	88,5	66,7	18,5	86,1	65,6	19,8	83,1	64,1	21,4	79,5	62,2	23,5	75,4	59,9	26,5	70,7	57,2	31,0
			27	88,8	79,9	18,5	86,5	78,7	19,8	83,5	77,1	21,4	80,0	75,0	23,6	75,9	71,7	26,6	71,2	69,3	31,1
		19	24	95,2	52,1	18,9	92,4	50,9	20,2	89,2	49,6	21,8	85,3	48,1	24,0	80,9	46,3	27,0	75,9	44,3	31,5
			27	96,1	65,5	18,9	93,4	64,3	20,3	90,1	62,9	21,9	86,3	61,2	24,1	81,9	59,1	27,1	76,9	56,6	31,6
			30	96,6	78,7	19,0	93,9	77,5	20,3	90,6	76,0	22,0	86,8	74,1	24,2	82,4	71,7	27,2	77,5	68,7	31,7
		22	27	103,1	50,6	19,4	100,1	49,4	20,7	96,5	48,2	22,4	92,4	46,8	24,7	87,7	45,2	27,7	82,4	43,3	32,3
			30	104,1	63,9	19,5	101,2	62,7	20,8	97,6	61,4	22,5	93,5	59,8	24,7	88,8	57,9	27,8	83,5	55,7	32,4
			33	104,8	77,0	19,5	101,8	75,9	20,9	98,3	74,5	22,6	94,2	72,8	24,8	89,5	70,6	27,9	84,2	68,0	32,4

**HEATING CAPACITIES**

ASH+CIH 085D			Air inlet temperature at condenser (dry bulb)													
Airflow m <sup>3</sup> /h	Indoor dry bulb °C		-10 °C		-5 °C		0 °C		5 °C		7 °C		10 °C		15 °C	
			NH	AC	NH	AC	NH	AC	NH	AC	NH	AC	NH	AC	NH	AC
Minimum	14000	15	51,6	14,2	59,7	15,8	67,7	17,3	75,7	18,8	78,8	19,4	83,6	20,3	91,5	21,9
		18	51,6	15,2	59,5	16,9	67,4	18,5	75,2	20,1	78,4	20,7	83,0	21,7	90,8	23,4
		20	51,6	15,9	59,4	17,6	67,2	19,3	74,9	21,0	78,0	21,7	82,6	22,7	90,3	24,5
		23	51,5	17,1	59,2	18,9	66,9	20,6	74,5	22,4	77,5	23,1	82,1	24,2	89,6	26,2
		25	n/a	n/a	59,1	19,7	66,7	21,5	74,2	23,4	77,2	24,2	81,7	25,3	89,1	27,4
		27	n/a	n/a	n/a	n/a	66,5	22,5	73,9	24,4	76,9	25,2	81,3	26,5	88,7	28,6
Nominal	16250	15	53,1	14,1	61,3	15,5	69,5	16,9	77,6	18,3	80,8	18,8	85,6	19,6	93,7	21,0
		19	53,1	15,5	61,1	17,0	69,1	18,5	77,0	20,0	80,2	20,6	84,9	21,5	92,7	23,0
		20	53,1	15,9	61,0	17,4	69,0	18,9	76,9	20,4	80,0	21,0	84,7	21,9	92,5	23,5
		23	53,0	17,0	60,9	18,6	68,7	20,2	76,4	21,8	79,5	22,5	84,1	23,4	91,8	25,1
		25	53,0	17,8	60,7	19,5	68,5	21,1	76,1	22,8	79,2	23,4	83,8	24,5	91,3	26,3
		27	n/a	n/a	60,6	20,3	68,3	22,0	75,8	23,8	78,9	24,5	83,4	25,6	90,9	27,5
Maximum	16725	15	53,2	14,0	61,5	15,4	69,6	16,7	77,8	18,1	81,0	18,6	85,9	19,4	93,9	20,8
		19	53,2	15,4	61,2	16,9	69,2	18,3	77,2	19,8	80,4	20,3	85,1	21,2	93,0	22,7
		20	53,2	15,8	61,2	17,3	69,1	18,8	77,0	20,2	80,2	20,8	84,9	21,7	92,8	23,2
		23	53,1	16,9	61,0	18,5	68,8	20,0	76,6	21,6	79,7	22,2	84,3	23,2	92,1	24,8
		25	53,1	17,7	60,9	19,3	68,6	20,9	76,3	22,5	79,4	23,2	84,0	24,2	91,6	25,9
		27	n/a	n/a	60,8	20,2	68,4	21,8	76,0	23,5	79,0	24,2	83,6	25,3	91,1	27,1

<b>Indoor fan power input (kw)</b>			
Minimum airflow	3,28	Nominal airflow	4
Maximum airflow	4,16		
<b>Outdoor fan power input (kw)</b>			
Nominal airflow	1,64		

<b>GC (kW)</b> :	Gross cooling capacity	<b>NH (kW)</b> :	Net heating capacity	<b>SC (kW)</b> :	Sensible cooling capacity	<b>AC (kW)</b> :	Compressor absorbed power
------------------	------------------------	------------------	----------------------	------------------	---------------------------	------------------	---------------------------



**COOLING CAPACITIES**

ASC/ASH + CIC/CIH 0100D			Air inlet temperature at condenser (dry bulb)																		
Airflow m³/h	Indoor wet bulb °C	Indoor dry bulb °C	20 °C			25 °C			30 °C			35 °C			40 °C			45 °C			
			GC	SC	AC	GC	SC	AC	GC	SC	AC	GC	SC	AC	GC	SC	AC	GC	SC	AC	
Minimum	17350	16	21	104,0	64,1	19,1	101,4	62,8	20,7	98,2	61,4	22,7	94,4	59,7	25,2	90,1	57,7	28,5	85,1	55,4	33,4
			24	104,4	77,3	19,1	101,8	76,0	20,7	98,6	74,5	22,7	94,9	72,6	25,2	90,5	70,4	28,6	85,6	67,7	33,5
			27	104,7	90,3	19,1	102,1	89,1	20,7	98,9	87,5	22,7	95,2	85,5	25,3	90,8	82,9	28,6	85,9	79,9	33,5
		19	24	112,9	62,9	19,7	109,9	61,6	21,4	106,4	60,2	23,3	102,3	58,6	25,9	97,7	56,7	29,2	92,5	54,6	34,0
			27	113,3	76,0	19,8	110,4	74,8	21,4	106,9	73,3	23,4	102,9	71,5	25,9	98,2	69,4	29,3	93,0	67,0	34,2
			30	113,6	89,0	19,8	110,7	87,8	21,4	107,2	86,2	23,4	103,2	84,3	26,0	98,6	82,0	29,4	93,3	79,2	34,2
		22	27	122,4	61,5	20,5	119,1	60,2	22,1	115,3	58,8	24,1	110,9	57,2	26,7	105,9	55,5	30,1	100,4	53,6	35,0
			30	122,9	74,4	20,5	119,7	73,1	22,2	115,9	71,7	24,2	111,5	70,1	26,8	106,5	68,2	30,2	101,0	65,9	35,1
			33	123,2	87,1	20,5	120,0	85,9	22,2	116,2	84,5	24,2	111,8	82,8	26,8	106,9	80,7	30,3	101,4	78,2	35,2
Nominal	20400	16	21	105,2	65,4	21,0	102,5	64,1	22,9	99,2	62,6	25,2	95,3	60,8	28,3	90,8	58,8	32,6	85,8	56,4	39,0
			24	105,7	79,7	21,0	103,0	78,4	22,9	99,7	76,8	25,3	95,8	74,8	28,4	91,4	72,4	32,7	86,3	69,6	39,2
			27	106,0	93,9	21,0	103,3	92,6	22,9	100,0	90,9	25,3	96,2	88,7	28,4	91,7	86,0	32,8	86,7	82,7	39,2
		19	24	114,2	64,2	21,6	111,2	62,8	23,5	107,5	61,4	25,9	103,3	59,7	28,9	98,5	57,8	33,2	93,2	55,7	39,5
			27	114,8	78,5	21,6	111,7	77,2	23,6	108,1	75,6	25,9	103,9	73,8	29,0	99,1	71,6	33,3	93,8	69,0	39,7
			30	115,1	92,7	21,7	112,1	91,4	23,6	108,5	89,8	26,0	104,3	87,7	29,1	99,5	85,2	33,4	94,2	82,2	39,7
		22	27	123,8	62,6	22,3	120,5	61,3	24,2	116,5	59,9	26,6	112,0	58,4	29,7	106,9	56,6	34,0	101,2	54,7	40,3
			30	124,4	76,8	22,4	121,0	75,5	24,3	117,1	74,1	26,7	112,6	72,4	29,8	107,5	70,4	34,1	101,9	68,1	40,4
			33	124,8	90,9	22,4	121,5	89,7	24,3	117,5	88,2	26,7	113,0	86,3	29,9	108,0	84,1	34,2	102,3	81,4	40,5
Maximum	22450	16	21	107,7	66,9	19,1	104,8	65,6	20,6	101,4	64,1	22,5	97,5	62,4	24,9	92,9	60,3	28,0	87,8	57,9	32,5
			24	108,2	82,3	19,2	105,4	80,9	20,7	102,0	79,3	22,6	98,0	77,2	25,0	93,5	74,8	28,2	88,4	71,9	32,7
			27	108,5	97,5	19,2	105,7	96,1	20,7	102,4	94,3	22,6	98,4	92,0	25,0	93,9	89,3	28,2	88,8	86,0	32,8
		19	24	116,7	65,5	19,8	113,6	64,2	21,3	109,9	62,7	23,3	105,6	61,1	25,7	100,7	59,2	28,9	95,3	57,0	33,4
			27	117,3	80,9	19,8	114,2	79,6	21,4	110,5	78,0	23,3	106,2	76,1	25,8	101,3	73,9	29,0	95,9	71,2	33,6
			30	117,7	96,1	19,9	114,6	94,8	21,5	110,9	93,1	23,4	106,6	91,0	25,8	101,8	88,5	29,1	96,3	85,4	33,7
		22	27	126,4	63,7	20,5	122,9	62,5	22,1	118,9	61,1	24,1	114,3	59,6	26,6	109,1	57,9	29,9	103,4	55,9	34,5
			30	127,0	79,0	20,6	123,6	77,8	22,2	119,5	76,3	24,2	115,0	74,6	26,7	109,8	72,6	30,0	104,0	70,2	34,7
			33	127,4	94,2	20,6	124,0	93,0	22,3	120,0	91,4	24,3	115,4	89,5	26,8	110,3	87,2	30,1	104,5	84,5	34,8

**HEATING CAPACITIES**

ASH+CIH 100D		Air inlet temperature at condenser (dry bulb)														
Airflow m³/h	Indoor dry bulb °C	-10 °C		-5 °C		0 °C		5 °C		7 °C		10 °C		15 °C		
		NH	AC	NH	AC	NH	AC	NH	AC	NH	AC	NH	AC	NH	AC	
Minimum	17350	15	68,2	17,1	79,5	19,3	90,7	21,5	101,8	23,6	106,2	24,5	112,7	25,9	123,4	28,2
		18	68,0	18,5	79,2	20,8	90,1	23,1	101,0	25,4	105,2	26,3	111,6	27,8	122,1	30,3
		20	68,0	19,6	78,9	21,9	89,8	24,3	100,4	26,7	104,7	27,6	111,0	29,1	121,3	31,8
		23	67,9	21,3	78,7	23,7	89,3	26,2	99,7	28,7	103,9	29,7	110,0	31,4	120,2	34,2
		25	n/a	n/a	n/a	n/a	89,0	27,5	99,3	30,2	103,4	31,3	109,4	33,0	119,4	36,0
		27	n/a	n/a	n/a	n/a	n/a	n/a	n/a	n/a	102,9	32,9	108,9	34,7	118,7	37,9
Nominal	20400	15	70,7	17,8	82,3	19,9	93,8	21,8	105,1	23,8	109,6	24,6	116,2	25,8	127,3	27,9
		19	70,5	20,0	81,8	22,1	92,9	24,2	103,9	26,3	108,3	27,1	114,8	28,5	125,5	30,8
		20	70,4	20,6	81,6	22,7	92,7	24,8	103,7	27,0	108,0	27,8	114,5	29,2	125,1	31,5
		23	70,3	22,5	81,3	24,7	92,2	26,9	102,9	29,1	107,1	30,0	113,5	31,5	123,9	34,0
		25	70,3	23,9	81,1	26,1	91,9	28,3	102,4	30,6	106,6	31,6	112,8	33,1	123,1	35,8
		27	n/a	n/a	81,0	27,6	91,6	29,9	102,0	32,3	106,1	33,3	112,2	34,9	122,4	37,7
Maximum	22450	15	69,3	15,6	81,1	17,5	92,7	19,4	104,2	21,2	108,7	22,0	115,5	23,1	126,7	25,0
		19	69,0	17,5	80,5	19,5	91,8	21,5	103,0	23,4	107,4	24,2	114,0	25,4	124,9	27,5
		20	68,9	18,0	80,3	20,1	91,6	22,0	102,7	24,0	107,1	24,8	113,7	26,0	124,5	28,1
		23	68,8	19,7	80,0	21,8	91,0	23,8	101,9	25,9	106,2	26,7	112,7	28,0	123,2	30,3
		25	68,7	20,9	79,8	23,0	90,7	25,1	101,4	27,2	105,7	28,1	112,0	29,4	122,5	31,8
		27	n/a	n/a	79,6	24,3	90,3	26,4	100,9	28,6	105,1	29,5	111,4	30,9	121,7	33,4

<b>Indoor fan power input (kw)</b>			
Minimum airflow	3,13	Nominal airflow	3,89
Maximum airflow	4,45		
<b>Outdoor fan power input (kw)</b>			
Nominal airflow	2,78		

<b>GC (kW) :</b> Gross cooling capacity	<b>NH (kW) :</b> Net heating capacity	<b>SC (kW) :</b> Sensible cooling capacity	<b>AC (kW) :</b> Compressor absorbed power
---	---------------------------------------	--	--

**COOLING CAPACITIES**

ASC/ASH + CIC/CIH 0120D			Air inlet temperature at condenser (dry bulb)																		
Airflow m³/h	Indoor wet bulb °C	Indoor dry bulb °C	20 °C			25 °C			30 °C			35 °C			40 °C			45 °C			
			GC	SC	AC	GC	SC	AC	GC	SC	AC	GC	SC	AC	GC	SC	AC	GC	SC	AC	
Minimum	19300	16	21	115,6	65,5	22,2	112,7	64,0	23,9	109,2	62,3	26,0	105,0	60,3	28,6	100,1	58,0	32,0	94,6	55,4	37,0
			24	116,0	80,7	22,3	113,1	79,2	24,0	109,6	77,3	26,0	105,5	75,0	28,6	100,6	72,3	32,1	95,2	69,2	37,1
			27	116,7	94,4	22,3	113,9	92,8	24,0	110,4	90,8	26,1	106,3	88,4	28,7	101,5	85,4	32,2	96,1	81,9	37,2
		19	24	125,7	64,2	22,9	122,5	62,7	24,6	118,6	61,1	26,7	114,0	59,2	29,3	108,8	57,1	32,8	102,9	54,7	37,7
			27	126,0	79,7	22,9	122,7	78,2	24,6	118,9	76,4	26,7	114,4	74,3	29,4	109,2	71,8	32,9	103,3	68,8	37,9
			30	126,6	93,5	23,0	123,4	92,0	24,7	119,6	90,1	26,8	115,1	87,8	29,4	109,9	85,0	33,0	104,2	81,7	38,0
		22	27	137,0	61,6	23,6	133,4	60,2	25,4	129,1	58,7	27,4	124,2	57,0	30,1	118,6	55,2	33,6	112,3	53,1	38,6
			30	137,1	77,5	23,7	133,5	76,0	25,4	129,3	74,4	27,5	124,4	72,5	30,2	118,8	70,2	33,7	112,7	67,6	38,7
			33	137,5	91,5	23,7	134,0	90,1	25,4	129,8	88,3	27,6	125,0	86,2	30,2	119,5	83,7	33,8	113,3	80,8	38,8
Nominal	22700	16	21	117,8	68,6	23,5	114,7	67,1	25,3	110,9	65,4	27,4	106,5	63,3	30,2	101,5	60,9	33,9	95,8	58,2	39,4
			24	118,3	85,5	23,5	115,2	83,9	25,3	111,5	81,9	27,5	107,2	79,5	30,3	102,1	76,6	34,0	96,5	73,3	39,4
			27	119,2	101,0	23,6	116,1	99,3	25,4	112,5	97,2	27,5	108,2	94,5	30,3	103,2	91,2	34,1	97,6	87,4	39,5
		19	24	128,0	67,3	24,2	124,5	65,8	25,9	120,4	64,2	28,1	115,6	62,3	30,9	110,2	60,1	34,7	104,2	57,6	40,1
			27	128,4	84,7	24,2	125,0	83,1	26,0	120,9	81,2	28,2	116,2	78,9	31,0	110,8	76,3	34,8	104,8	73,2	40,2
			30	129,1	100,4	24,2	125,8	98,7	26,0	121,7	96,7	28,2	117,1	94,2	31,1	111,7	91,1	34,9	105,7	87,5	40,3
		22	27	139,4	64,6	24,9	135,5	63,3	26,7	131,0	61,8	28,9	125,9	60,1	31,8	120,1	58,2	35,6	113,7	56,1	41,0
			30	139,6	82,5	24,9	135,8	81,0	26,7	131,4	79,3	29,0	126,3	77,3	31,8	120,6	74,9	35,7	114,2	72,2	41,1
			33	140,2	98,5	25,0	136,5	97,0	26,8	132,1	95,2	29,0	127,1	92,9	31,9	121,4	90,2	35,7	115,0	86,9	41,2
Maximum	24950	16	21	119,8	69,4	23,3	116,6	68,0	25,0	112,7	66,3	27,0	108,2	64,2	29,6	103,0	61,9	33,0	97,2	59,1	37,9
			24	120,5	87,6	23,4	117,3	86,0	25,0	113,4	84,0	27,1	108,9	81,6	29,6	103,8	78,6	33,1	98,0	75,2	38,0
			27	121,5	104,4	23,4	118,3	102,7	25,1	114,5	100,4	27,1	110,1	97,7	29,7	105,0	94,3	33,2	99,2	91,3	38,0
		19	24	130,1	67,9	24,0	126,5	66,5	25,7	122,3	64,9	27,8	117,4	63,1	30,4	111,8	60,9	33,9	105,6	58,5	38,9
			27	130,6	86,7	24,1	127,1	85,1	25,8	122,9	83,2	27,8	118,0	80,9	30,5	112,5	78,3	34,0	106,4	75,1	39,0
			30	131,5	103,7	24,1	128,0	102,0	25,8	123,8	100,0	27,9	119,0	97,4	30,5	113,6	94,3	34,0	107,5	90,6	39,0
		22	27	141,6	65,0	24,8	137,6	63,8	26,5	133,0	62,4	28,6	127,7	60,8	31,3	121,8	58,9	34,9	115,3	56,8	39,9
			30	142,0	84,3	24,8	138,0	82,9	26,6	133,5	81,2	28,7	128,3	79,2	31,4	122,4	76,9	35,0	115,9	74,1	40,0
			33	142,7	101,8	24,9	138,8	100,3	26,6	134,3	98,4	28,7	129,1	96,1	31,4	123,3	93,3	35,0	116,8	90,0	40,1

**HEATING CAPACITIES**

ASH+CIH 120D			Air inlet temperature at condenser (dry bulb)													
Airflow m³/h	Indoor dry bulb °C	-10 °C		-5 °C		0 °C		5 °C		7 °C		10 °C		15 °C		
		NH	AC	NH	AC	NH	AC	NH	AC	NH	AC	NH	AC	NH	AC	
Minimum	19300	15	76,3	20,3	88,2	22,7	100,0	25,1	111,7	27,4	116,3	28,4	123,2	29,9	134,6	32,4
		18	76,3	21,9	88,0	24,4	99,5	26,8	110,9	29,3	115,4	30,3	122,2	31,9	133,3	34,6
		20	76,4	23,1	87,9	25,6	99,2	28,1	110,4	30,7	114,9	31,7	121,5	33,3	132,4	36,2
		23	76,6	25,0	87,8	27,6	98,9	30,2	109,8	32,9	114,2	34,0	120,6	35,8	131,3	38,8
		25	n/a	n/a	87,9	29,1	98,8	31,7	109,5	34,5	113,8	35,7	120,1	37,5	130,6	40,8
27	n/a	n/a	n/a	n/a	n/a	n/a	109,2	36,3	113,4	37,5	119,7	39,4	130,0	42,9		
Nominal	22700	15	78,4	20,3	90,7	22,4	102,8	24,6	114,8	26,7	119,6	27,5	126,7	28,8	138,4	31,1
		19	78,4	22,5	90,3	24,7	102,1	26,9	113,7	29,1	118,3	30,1	125,2	31,4	136,5	33,9
		20	78,4	23,1	90,2	25,4	101,9	27,6	113,4	29,8	118,0	30,7	124,8	32,2	136,1	34,6
		23	78,6	25,1	90,1	27,4	101,5	29,6	112,8	32,0	117,2	32,9	123,9	34,4	134,8	37,1
		25	78,7	26,5	90,1	28,8	101,3	31,1	112,4	33,5	116,8	34,5	123,3	36,1	134,1	38,9
27	n/a	n/a	90,1	30,3	101,2	32,7	112,1	35,2	116,4	36,3	122,8	37,9	133,4	40,8		
Maximum	24950	15	78,8	19,5	91,3	21,6	103,6	23,5	115,8	25,5	120,6	26,3	127,9	27,5	139,8	29,6
		19	78,7	21,7	90,8	23,8	102,8	25,8	114,6	27,9	119,3	28,7	126,3	30,0	137,8	32,2
		20	78,7	22,3	90,7	24,4	102,6	26,4	114,3	28,5	119,0	29,3	125,9	30,6	137,4	32,9
		23	78,8	24,3	90,5	26,3	102,1	28,4	113,6	30,5	118,1	31,4	124,9	32,8	136,1	35,2
		25	78,9	25,7	90,5	27,7	101,9	29,8	113,2	32,0	117,7	32,9	124,3	34,3	135,3	36,8
27	79,1	27,1	90,5	29,2	101,7	31,3	112,8	33,6	117,2	34,5	123,8	36,0	134,6	38,6		

<b>Indoor fan power input (kw)</b>			
Minimum airflow	4,15	Nominal airflow	5,17
Maximum airflow	5,92		
<b>Outdoor fan power input (kw)</b>			
Nominal airflow	2,78		

<b>GC (kW)</b> :	Gross cooling capacity	<b>NH (kW)</b> :	Net heating capacity	<b>SC (kW)</b> :	Sensible cooling capacity	<b>AC (kW)</b> :	Compressor absorbed power
------------------	------------------------	------------------	----------------------	------------------	---------------------------	------------------	---------------------------

**COOLING CAPACITIES**

ASC/ASH + CIC/CIH 140D			Air inlet temperature at condenser (dry bulb)																		
Airflow m <sup>3</sup> /h	Indoor wet bulb °C	Indoor dry bulb °C	20 °C			25 °C			30 °C			35 °C			40 °C			45 °C			
			GC	SC	AC	GC	SC	AC	GC	SC	AC	GC	SC	AC	GC	SC	AC	GC	SC	AC	
Minimum	21000	16	21	139,0	83,3	28,5	135,5	81,5	30,5	131,1	79,5	33,0	126,0	77,1	36,1	120,0	74,3	40,3	113,3	71,1	46,2
			24	139,5	100,2	28,6	136,0	98,4	30,6	131,6	96,3	33,1	126,5	93,6	36,2	120,6	90,5	40,4	113,8	86,8	46,3
			27	139,6	116,8	28,6	136,1	115,1	30,6	131,8	112,8	33,1	126,7	110,0	36,3	120,8	106,5	40,4	114,1	102,3	46,4
		19	24	151,3	81,9	29,4	147,3	80,0	31,5	142,5	77,9	34,0	136,9	75,6	37,2	130,5	73,0	41,4	123,3	70,0	47,4
			27	151,9	98,5	29,4	147,9	96,7	31,5	143,1	94,6	34,0	137,6	92,1	37,2	131,2	89,2	41,5	124,0	85,8	47,5
			30	152,1	115,0	29,5	148,2	113,3	31,5	143,4	111,1	34,1	137,9	108,4	37,3	131,5	105,2	41,6	124,3	101,3	47,6
		22	27	164,6	80,1	30,3	160,2	78,2	32,4	154,9	76,2	35,0	148,9	74,0	38,2	142,1	71,5	42,6	134,4	68,8	48,7
			30	165,3	96,4	30,3	160,9	94,7	32,5	155,6	92,6	35,0	149,6	90,3	38,3	142,8	87,6	42,6	135,2	84,4	48,7
			33	165,6	112,6	30,4	161,2	110,9	32,5	156,0	108,9	35,1	150,0	106,4	38,4	143,2	103,5	42,7	135,6	100,0	48,8
Nominal	24750	16	21	142,4	86,0	29,9	138,6	84,2	32,0	134,1	82,1	34,5	128,7	79,6	37,8	122,6	76,7	42,2	115,6	73,4	48,5
			24	142,9	104,6	29,9	139,2	102,8	32,0	134,7	100,5	34,6	129,4	97,7	37,9	123,2	94,4	42,3	116,3	90,5	48,6
			27	143,2	123,0	30,0	139,5	121,1	32,1	135,0	118,7	34,7	129,7	115,7	38,0	123,5	111,9	42,4	116,6	107,4	48,7
		19	24	154,9	84,3	30,7	150,7	82,4	32,9	145,7	80,4	35,5	139,9	78,0	38,9	133,3	75,3	43,4	125,9	72,3	49,8
			27	155,5	102,8	30,8	151,4	101,0	32,9	146,4	98,8	35,6	140,6	96,2	38,9	134,0	93,1	43,4	126,6	89,5	49,8
			30	155,9	121,2	30,8	151,7	119,4	33,0	146,8	117,1	35,6	141,0	114,2	39,0	134,4	110,8	43,5	127,1	106,6	49,9
		22	27	168,4	82,3	31,6	163,7	80,4	33,8	158,3	78,4	36,5	152,1	76,2	40,0	145,0	73,7	44,5	137,1	70,9	51,1
			30	169,1	100,6	31,7	164,5	98,8	33,9	159,1	96,7	36,6	152,9	94,3	40,0	145,8	91,5	44,6	138,0	88,2	51,1
			33	169,6	118,8	31,7	165,0	117,0	33,9	159,6	114,9	36,6	153,4	112,3	40,1	146,4	109,1	44,7	138,5	105,4	51,2

On size 140, nominal airflow rate is also maximum one reachable by the unit

**HEATING CAPACITIES**

ASH+CIH 140D		Air inlet temperature at condenser (dry bulb)														
Airflow m <sup>3</sup> /h	Indoor dry bulb °C	-10 °C		-5 °C		0 °C		5 °C		7 °C		10 °C		15 °C		
		NH	AC	NH	AC	NH	AC	NH	AC	NH	AC	NH	AC	NH	AC	
Minimum	21000	15	89,5	26,7	103,3	29,8	116,9	32,9	130,3	35,9	135,7	37,2	143,6	39,1	156,6	42,4
		18	89,7	28,9	103,2	32,0	116,4	35,2	129,5	38,4	134,7	39,7	142,4	41,7	155,1	45,3
		20	89,9	30,4	103,1	33,6	116,1	36,8	129,0	40,2	134,1	41,5	141,7	43,7	154,2	47,4
		23	90,0	32,9	102,9	36,2	115,6	39,5	128,2	43,0	133,1	44,5	140,5	46,8	152,7	50,9
		25	n/a	n/a	n/a	n/a	115,3	41,5	127,6	45,1	132,5	46,7	139,7	49,1	151,7	53,4
		27	n/a	n/a	n/a	n/a	n/a	n/a	n/a	n/a	n/a	n/a	n/a	n/a	n/a	150,7
Nominal	24750	15	91,1	25,8	105,3	28,6	119,3	31,4	133,1	34,1	138,6	35,2	146,8	36,9	160,3	39,9
		19	91,3	28,7	105,1	31,5	118,6	34,4	132,0	37,2	137,3	38,4	145,2	40,2	158,3	43,4
		20	91,4	29,4	105,0	32,3	118,5	35,2	131,7	38,1	137,0	39,3	144,8	41,1	157,7	44,4
		23	91,5	31,9	104,8	34,8	117,9	37,7	130,9	40,8	136,0	42,0	143,7	44,0	156,2	47,5
		25	91,6	33,6	104,7	36,6	117,6	39,6	130,3	42,7	135,4	44,0	142,9	46,1	155,2	49,7
		27	n/a	n/a	n/a	n/a	117,2	41,5	129,8	44,8	134,7	46,2	142,1	48,3	154,2	52,2

On size 140, nominal airflow rate is also maximum one reachable by the unit

<b>Indoor fan power input (kw)</b>			
Minimum airflow	4,44	Nominal airflow	5,61
Maximum airflow			
<b>Outdoor fan power input (kw)</b>			
Nominal airflow	3,68		
<b>GC (kW) :</b>	Gross cooling capacity	<b>NH (kW) :</b>	Net heating capacity
<b>SC (kW) :</b>	Sensible cooling capacity	<b>AC (kW) :</b>	Compressor absorbed power

**COOLING CAPACITIES**

ASC 020S	Air inlet temperature at condenser (wet bulb)										
	25 °C		30 °C		35 °C		40 °C		45 °C		
	TC	PI	TC	PI	TC	PI	TC	PI	TC	PI	
Evaporating temperature °C											
0	17,3	5,27	16,8	5,55	15,9	6,01	14,7	6,67	13,5	7,42	
5	20,3	5,49	19,8	5,71	18,6	6,30	17,2	6,97	15,8	7,73	
7	21,6	5,59	21,0	5,84	19,7	6,43	18,3	7,10	16,8	7,86	
10	24,0	5,64	23,0	6,03	21,5	6,64	20,0	7,31	18,4	8,08	
15	-										

**HEATING CAPACITIES**

ASH 020S	Air inlet temperature at condenser (wet bulb)													
	-11 °C		-6 °C		-1 °C		4 °C		6 °C		8 °C		18 °C	
	TH	PI	TH	PI	TH	PI	TH	PI	TH	PI	TH	PI	TH	PI
Condensing temperature °C														
30	12,9	3,89	15,0	3,92	17,4	3,95	20,0	3,98	21,1	3,99	22,4	4,01	29,9	4,15
35	12,9	4,36	14,8	4,38	17,1	4,41	19,6	4,43	20,8	4,45	22,0	4,46	29,2	4,58
40	12,8	4,88	14,7	4,90	16,9	4,92	19,3	4,94	20,4	4,96	21,6	4,97	28,6	5,07
45	-	-	14,6	5,49	16,7	5,51	19,0	5,52	20,1	5,53	21,2	5,54	27,9	5,61
50	-	-	-	-	16,6	6,17	18,8	6,18	19,8	6,18	20,9	6,19	27,3	6,24
55	-	-	-	-	-	-	18,6	6,93	19,5	6,93	20,5	6,93	26,6	6,95

**Outdoor fan power input (kw)**

 Nominal airflow 0,4
**COOLING CAPACITIES**

ASC 025S	Air inlet temperature at condenser (wet bulb)									
	25 °C		30 °C		35 °C		40 °C		45 °C	
	TC	PI	TC	PI	TC	PI	TC	PI	TC	PI
Evaporating temperature °C										
0	21,9	6,71	21,3	7,01	20,0	7,64	18,5	8,46	16,8	9,41
5	25,6	6,95	24,9	7,25	23,3	7,95	21,6	8,78	19,8	9,73
7	27,2	7,05	26,4	7,39	24,7	8,10	22,9	8,93	21,0	9,88
10	30,1	7,11	28,6	7,64	26,8	8,35	24,9	9,18	22,9	10,1
15	-									

**HEATING CAPACITIES**

ASH 025S	Air inlet temperature at condenser (wet bulb)													
	-11 °C		-6 °C		-1 °C		4 °C		6 °C		8 °C		18 °C	
	TH	PI	TH	PI	TH	PI	TH	PI	TH	PI	TH	PI	TH	PI
Condensing temperature °C														
30	16,5	5,22	19,0	5,22	22,0	5,21	25,3	5,20	26,7	5,19	28,3	5,20	37,8	5,29
35	16,3	5,77	18,8	5,76	21,7	5,74	24,9	5,73	26,3	5,73	27,9	5,73	37,0	5,84
40	16,2	6,41	18,7	6,38	21,5	6,35	24,5	6,32	25,9	6,32	27,4	6,32	36,1	6,41
45	-	-	18,5	7,11	21,2	7,05	24,1	7,01	25,5	6,99	26,9	6,98	35,2	7,06
50	-	-	-	-	20,9	7,88	23,8	7,8	25,0	7,78	26,4	7,76	34,4	7,79
55	-	-	-	-	-	-	23,4	8,74	24,6	8,70	25,9	8,67	33,5	8,63

**Outdoor fan power input (kw)**

 Nominal airflow 0,67

<b>TC (kW) :</b> Total cooling capacity	<b>TH (kW) :</b> Total heating capacity	<b>PI (kW) :</b> Power input
---	---	------------------------------

### COOLING CAPACITIES

ASC 030S	Air inlet temperature at condenser (wet bulb)										
	25 °C		30 °C		35 °C		40 °C		45 °C		
	TC	PI	TC	PI	TC	PI	TC	PI	TC	PI	
Evaporating temperature °C											
0	25,4	7,94	24,7	8,25	23,0	9,11	21,1	10,1	19,1	11,2	
5	29,7	8,20	28,8	8,60	26,8	9,48	24,6	10,5	22,4	11,6	
7	31,8	8,21	30,5	8,76	28,4	9,63	26,1	10,6	23,8	11,7	
10	35,2	8,24	33,1	9,01	30,8	9,90	28,4	10,9	25,9	12,0	
15	-										

### HEATING CAPACITIES

ASH 030S	Air inlet temperature at condenser (wet bulb)													
	-11 °C		-6 °C		-1 °C		4 °C		6 °C		8 °C		18 °C	
	TH	PI	TH	PI	TH	PI	TH	PI	TH	PI	TH	PI	TH	PI
Condensing temperature °C														
30	18,9	6,01	21,8	6,01	25,2	6,00	28,9	5,99	30,5	5,99	32,3	6,00	42,7	6,11
35	18,7	6,70	21,5	6,69	24,8	6,67	28,4	6,65	30,0	6,65	31,8	6,65	41,9	6,71
40	18,5	7,46	21,3	7,45	34,5	7,42	28,0	7,39	29,5	7,38	31,2	7,37	41,0	7,39
45	-		21,1	8,32	24,2	8,28	27,5	8,24	29,0	8,22	30,7	8,20	40,1	8,17
50	-		-		23,9	9,26	27,1	9,20	28,6	9,18	30,1	9,15	39,1	9,07
55	-		-		-		26,7	10,3	28,1	10,3	29,6	10,2	38,1	10,1

<b>Outdoor fan power input (kw)</b>	
Nominal airflow	0,8

### COOLING CAPACITIES

ASC 035S	Air inlet temperature at condenser (wet bulb)									
	25 °C		30 °C		35 °C		40 °C		45 °C	
	TC	PI	TC	PI	TC	PI	TC	PI	TC	PI
Evaporating temperature °C										
0	32,0	9,83	31,4	10,2	29,4	11,2	27,3	12,3	25,0	13,5
5	37,5	10,1	36,4	10,6	34,1	11,7	31,6	12,8	29,0	14,1
7	40,1	10,1	38,5	10,8	36,1	11,9	33,5	13,0	30,7	14,3
10	44,2	10,2	41,8	11,2	39,1	12,2	36,3	13,4	33,3	14,7
15	50,4	10,8	47,5	11,8	44,5	12,8	41,2	14,0	37,8	15,3

### HEATING CAPACITIES

ASH 035S	Air inlet temperature at condenser (wet bulb)													
	-11 °C		-6 °C		-1 °C		4 °C		6 °C		8 °C		18 °C	
	TH	PI	TH	PI	TH	PI	TH	PI	TH	PI	TH	PI	TH	PI
Condensing temperature °C														
30	23,9	7,41	27,4	7,46	31,5	7,49	36,0	7,51	37,9	7,52	40,0	7,55	53,1	7,84
35	23,7	8,10	27,2	8,19	31,2	8,24	35,5	8,25	37,4	8,26	39,5	8,27	52,1	8,45
40	23,5	8,85	27,0	8,99	30,9	9,07	35,1	9,10	37,0	9,10	39,0	9,11	51,2	9,20
45	23,4	9,65	26,7	9,86	30,5	9,98	34,7	10,0	36,5	10,1	38,5	10,1	50,2	10,1
50	23,2	10,5	26,5	10,8	30,2	11,0	34,2	11,1	36,0	11,1	37,9	11,1	49,1	11,2
55	23,0	11,4	26,3	11,8	29,9	12,1	33,8	12,2	35,4	12,3	37,3	12,3	48,0	12,4

<b>Outdoor fan power input (kw)</b>	
Nominal airflow	0,82

<b>TC (kW) :</b> Total cooling capacity	<b>TH (kW) :</b> Total heating capacity	<b>PI (kW) :</b> Power input
---	---	------------------------------

**COOLING CAPACITIES**

ASC 040S	Air inlet temperature at condenser (wet bulb)										
	25 °C		30 °C		35 °C		40 °C		45 °C		
	TC	PI	TC	PI	TC	PI	TC	PI	TC	PI	
Evaporating temperature °C											
0	37,5	11,6	36,6	12,0	34,3	13,2	31,8	14,5	29,1	16,0	
5	44,3	11,8	42,4	12,6	39,7	13,9	36,8	15,2	33,7	16,7	
7	47,4	11,8	44,9	12,9	42,0	14,1	38,9	15,5	35,7	17,0	
10	51,6	12,2	48,6	13,3	45,5	14,6	42,2	16,0	38,6	17,5	
15	58,6	12,9	55,2	14,1	51,6	15,4	47,7	16,8	-	-	

**HEATING CAPACITIES**

ASH 040S	Air inlet temperature at condenser (wet bulb)													
	-11 °C		-6 °C		-1 °C		4 °C		6 °C		8 °C		18 °C	
	TH	PI	TH	PI	TH	PI	TH	PI	TH	PI	TH	PI	TH	PI
Condensing temperature °C														
30	26,5	8,54	30,4	8,64	34,9	8,68	39,8	8,70	42,0	8,71	44,3	8,73	58,7	8,99
35	26,3	9,34	30,2	9,48	34,6	9,56	39,4	9,59	41,5	9,59	43,7	9,60	57,7	9,74
40	26,2	10,2	30,0	10,4	34,3	10,5	39,0	10,6	41,0	10,6	43,2	10,6	56,7	10,7
45	16,1	11,1	29,8	11,4	34,0	11,6	38,6	11,7	40,6	11,7	42,7	11,7	55,7	11,8
50	25,9	12,1	29,6	12,5	33,8	12,8	38,2	12,9	40,2	12,9	42,2	13,0	54,7	13,0
55	25,8	13,2	29,5	13,7	33,5	14,0	37,8	14,2	39,7	14,3	41,7	14,4	53,7	14,4

<b>Outdoor fan power input (kw)</b>	
Nominal airflow	0,82

**COOLING CAPACITIES**

ASC 045D	Air inlet temperature at condenser (wet bulb)									
	25 °C		30 °C		35 °C		40 °C		45 °C	
	TC	PI	TC	PI	TC	PI	TC	PI	TC	PI
Evaporating temperature °C										
0	43,8	13,4	42,5	14,0	40,0	15,3	37,0	16,9	33,7	18,8
5	51,2	13,9	49,8	14,5	46,6	15,9	43,2	17,6	39,6	19,5
7	54,5	14,1	52,7	14,8	49,4	16,2	45,8	17,9	42,0	19,8
10	60,2	14,2	57,2	15,3	53,6	16,7	49,8	18,4	45,7	20,3
15	-	-	-	-	-	-	-	-	-	-

**HEATING CAPACITIES**

ASH 045D	Air inlet temperature at condenser (wet bulb)													
	-11 °C		-6 °C		-1 °C		4 °C		6 °C		8 °C		18 °C	
	TH	PI	TH	PI	TH	PI	TH	PI	TH	PI	TH	PI	TH	PI
Condensing temperature °C														
30	32.9	10.4	38.0	10.4	44.0	10.4	50.5	10.4	53.4	10.4	56.7	10.4	75.7	10.6
35	32.7	11.5	37.7	11.5	43.4	11.5	49.8	11.5	52.6	11.5	55.7	11.5	73.9	11.7
40	32.4	12.8	37.3	12.8	42.9	12.7	49.0	12.7	51.7	12.7	54.7	12.7	72.2	12.8
45	-	-	36.9	14.2	42.4	14.1	48.3	14.0	50.9	14.0	53.8	14.0	70.5	14.1
50	-	-	-	-	41.8	15.8	47.5	15.6	50.1	15.6	52.8	15.5	68.7	15.6
55	-	-	-	-	-	-	46.8	17.5	49.3	17.4	51.9	17.3	67.0	17.3

<b>Outdoor fan power input (kw)</b>	
Nominal airflow	1,34

<b>TC (kW) :</b> Total cooling capacity	<b>TH (kW) :</b> Total heating capacity	<b>PI (kW) :</b> Power input
---	---	------------------------------



### COOLING CAPACITIES

ASC 055D	Air inlet temperature at condenser (wet bulb)										
	25 °C		30 °C		35 °C		40 °C		45 °C		
	TC	PI	TC	PI	TC	PI	TC	PI	TC	PI	
Evaporating temperature °C											
0	50,8	15,9	49,4	16,5	45,9	18,2	42,2	20,2	38,2	22,4	
5	59,5	16,4	57,5	17,2	53,5	19,0	49,3	20,9	44,8	23,2	
7	63,7	16,4	60,9	17,5	56,7	19,3	52,3	21,2	47,5	23,5	
10	70,4	16,5	66,2	18,0	61,6	19,8	56,9	21,8	51,8	24,0	
15	-										

### HEATING CAPACITIES

ASH 055D	Air inlet temperature at condenser (wet bulb)													
	-11 °C		-6 °C		-1 °C		4 °C		6 °C		8 °C		18 °C	
	TH	PI	TH	PI	TH	PI	TH	PI	TH	PI	TH	PI	TH	PI
Condensing temperature °C														
30	37,7	12,0	43,6	12,0	50,4	12,0	57,8	12,0	61,0	12,0	64,6	12,0	85,4	12,2
35	37,3	13,4	43,1	13,4	49,7	13,3	56,9	13,3	60,0	13,3	63,6	13,3	83,8	13,4
40	37,0	14,9	42,6	14,9	49,0	14,9	56,0	14,8	59,0	14,8	62,5	14,8	82,1	14,8
45	-		42,2	16,6	48,4	16,6	55,1	16,5	58,1	16,4	61,4	16,4	80,2	16,3
50	-		-		47,8	18,5	54,2	18,4	57,1	18,4	60,2	18,3	78,3	18,1
55	-		-		-		53,5	20,6	56,2	20,5	59,1	20,5	76,3	20,2

<b>Outdoor fan power input (kw)</b>	
Nominal airflow	1,6

### COOLING CAPACITIES

ASC 070D	Air inlet temperature at condenser (wet bulb)									
	25 °C		30 °C		35 °C		40 °C		45 °C	
	TC	PI	TC	PI	TC	PI	TC	PI	TC	PI
Evaporating temperature °C										
0	64,1	19,7	62,7	20,3	58,7	22,3	54,5	24,5	50,0	26,9
5	75,0	20,3	72,8	21,2	68,2	23,3	63,3	25,6	58,1	28,1
7	80,3	20,3	77,0	21,7	72,1	23,7	66,9	26,1	61,4	28,6
10	88,5	20,5	83,5	22,3	78,3	24,4	72,6	26,8	66,6	29,3
15	101	21,7	95,0	23,6	88,9	25,7	82,4	28,1	75,5	30,7

### HEATING CAPACITIES

ASH 070D	Air inlet temperature at condenser (wet bulb)													
	-11 °C		-6 °C		-1 °C		4 °C		6 °C		8 °C		18 °C	
	TH	PI	TH	PI	TH	PI	TH	PI	TH	PI	TH	PI	TH	PI
Condensing temperature °C														
30	47,9	14,8	54,9	14,9	63,0	15,0	71,9	15,0	75,8	15,1	80,1	15,1	106	15,7
35	47,5	16,2	54,4	16,4	62,3	16,5	71,0	16,5	74,9	16,5	79,0	16,5	104	16,9
40	47,1	17,7	53,9	18,0	61,7	18,1	70,2	18,2	73,9	18,2	78,0	18,2	102	18,4
45	46,7	19,3	53,5	19,7	61,1	20,0	69,3	20,1	72,9	20,1	76,9	20,1	100	20,2
50	46,3	21,0	53,0	21,6	60,4	22,0	68,4	22,2	71,9	22,2	75,8	22,2	98,2	22,3
55	46,0	22,9	52,5	23,7	59,8	24,2	67,5	24,5	70,9	24,6	74,6	24,6	96,1	24,7

<b>Outdoor fan power input (kw)</b>	
Nominal airflow	1,64

<b>TC (kW) :</b> Total cooling capacity	<b>TH (kW) :</b> Total heating capacity	<b>PI (kW) :</b> Power input
---	---	------------------------------

**COOLING CAPACITIES**

ASC 085D	Air inlet temperature at condenser (wet bulb)										
	25 °C		30 °C		35 °C		40 °C		45 °C		
	TC	PI	TC	PI	TC	PI	TC	PI	TC	PI	
Evaporating temperature °C											
0	74,9	23,3	73,3	24,1	68,6	26,5	63,6	29,1	58,3	31,9	
5	88,6	23,6	84,9	25,3	79,4	27,7	73,6	30,5	67,5	33,4	
7	94,8	23,7	89,7	25,8	83,9	28,3	77,8	31,0	71,3	34,0	
10	103,2	24,3	97,3	26,6	90,9	29,1	84,3	31,9	77,2	35,0	
15	117	25,9	110	28,1	103	30,7	95,5	33,5	-	-	

**HEATING CAPACITIES**

ASH 085D	Air inlet temperature at condenser (wet bulb)													
	-11 °C		-6 °C		-1 °C		4 °C		6 °C		8 °C		18 °C	
	TH	PI	TH	PI	TH	PI	TH	PI	TH	PI	TH	PI	TH	PI
Condensing temperature °C														
30	53,0	17,1	60,8	17,3	69,7	17,4	79,6	17,4	84,0	17,4	88,5	17,5	117	18,0
35	52,7	18,7	60,4	19,0	69,1	19,1	78,8	19,2	83,0	19,2	87,4	19,2	115	19,5
40	52,4	20,4	60,0	20,8	68,6	21,1	78,0	21,2	82,1	21,2	86,4	21,2	113	21,3
45	52,1	22,2	59,6	22,8	68,0	23,2	77,2	23,4	81,2	23,4	85,4	23,4	111	23,5
50	51,9	24,2	59,3	25,0	67,6	25,5	76,5	25,8	80,3	25,9	84,4	25,9	109	26,0
55	51,7	26,3	59,0	27,3	67,1	28,0	75,7	28,5	79,4	28,6	83,5	28,7	107	28,9

<b>Outdoor fan power input (kw)</b>	
Nominal airflow	1,64

**COOLING CAPACITIES**

ASC 100D	Air inlet temperature at condenser (wet bulb)									
	25 °C		30 °C		35 °C		40 °C		45 °C	
	TC	PI	TC	PI	TC	PI	TC	PI	TC	PI
Evaporating temperature °C										
0	92,0	28,4	89,1	29,8	84,1	32,3	78,0	35,5	71,5	39,1
5	108	29,1	104	30,7	97,7	33,7	90,7	37,0	83,3	40,6
7	115	29,3	110	31,3	104	34,3	96,1	37,6	88,2	41,3
10	126	30,1	120	32,3	112	35,3	104	38,6	95,8	42,4
15										

**HEATING CAPACITIES**

ASH 100D	Air inlet temperature at condenser (wet bulb)													
	-11 °C		-6 °C		-1 °C		4 °C		6 °C		8 °C		18 °C	
	TH	PI	TH	PI	TH	PI	TH	PI	TH	PI	TH	PI	TH	PI
Condensing temperature °C														
30	69,4	28,8	79,8	21,9	91,9	22,0	105	22,0	111	22,0	117	22,1	156	22,9
35	68,8	23,9	79,1	24,1	90,8	24,1	104	24,1	109	24,1	116	24,2	153	24,7
40	68,2	26,2	78,3	23,5	89,8	26,6	102	26,6	108	26,6	114	26,6	150	26,9
45	-	-	77,5	29,1	88,7	29,3	101	29,3	106	29,3	112	29,3	146	29,5
50	-	-	-	-	87,6	32,3	99,4	32,4	105	32,4	110	32,4	143	32,5
55	-	-	-	-	-	-	97,9	35,9	103	35,9	108	36,0	140	36,0

<b>Outdoor fan power input (kw)</b>	
Nominal airflow	2,78

<b>TC (kW) :</b> Total cooling capacity	<b>TH (kW) :</b> Total heating capacity	<b>PI (kW) :</b> Power input
---	---	------------------------------



### COOLING CAPACITIES

ASC 120D	Air inlet temperature at condenser (wet bulb)										
	25 °C		30 °C		35 °C		40 °C		45 °C		
	TC	PI	TC	PI	TC	PI	TC	PI	TC	PI	
Evaporating temperature °C											
0	102	30,8	99,0	32,2	93,4	35,0	86,6	38,5	79,3	42,4	
5	119	31,8	116	33,2	109	36,4	101	40,1	92,5	44,1	
7	127	32,0	123	33,8	115	37,1	107	40,7	97,9	44,8	
10	140	32,3	133	34,8	125	38,1	116	41,8	106	45,9	
15	-										

### HEATING CAPACITIES

ASH 120D	Air inlet temperature at condenser (wet bulb)													
	-11 °C		-6 °C		-1 °C		4 °C		6 °C		8 °C		18 °C	
	TH	PI	TH	PI	TH	PI	TH	PI	TH	PI	TH	PI	TH	PI
Condensing temperature °C														
30	75,8	23,6	87,2	23,8	100	23,8	115	23,9	121	23,9	128	24,0	170	24,9
35	75,1	26,0	86,3	26,2	99,1	26,3	113	26,3	119	26,3	126	26,3	167	26,9
40	74,5	28,5	85,5	28,8	98,0	29,0	112	29,0	118	29,0	124	29,0	163	29,3
45	-	-	84,7	31,8	96,9	32,0	110	32,1	116	32,1	122	32,1	160	32,2
50	-	-	-	-	95,8	35,4	109	35,5	114	35,6	120	35,6	156	35,6
55	-	-	-	-	-	-	107	39,4	112	39,4	118	39,5	153	39,4

<b>Outdoor fan power input (kw)</b>	
Nominal airflow	2,78

### COOLING CAPACITIES

ASC 140D	Air inlet temperature at condenser (wet bulb)									
	25 °C		30 °C		35 °C		40 °C		45 °C	
	TC	PI	TC	PI	TC	PI	TC	PI	TC	PI
Evaporating temperature °C										
0	125	38,5	122	39,8	115	43,5	106	47,8	97,1	52,5
5	146,6	39,1	142,5	41,5	133,1	45,4	123,4	49,7	113	54,6
7	157	40,1	151	42,3	141	46,2	131	50,6	120	55,5
10	174	40,3	164	43,6	153	47,6	142	52,0	130	56,9
15	-									

### HEATING CAPACITIES

ASH 140D	Air inlet temperature at condenser (wet bulb)													
	-11 °C		-6 °C		-1 °C		4 °C		6 °C		8 °C		18 °C	
	TH	PI	TH	PI	TH	PI	TH	PI	TH	PI	TH	PI	TH	PI
Condensing temperature °C														
30	90,7	29,3	104	29,6	120	29,7	138	29,9	146	30,0	154	30,1	205	30,9
35	90,1	32,2	103	32,4	119	32,6	136	32,7	143	32,8	152	32,9	201	33,5
40	89,7	35,4	103	35,7	118	35,8	134	36,0	141	36,0	149	36,1	197	36,5
45	-	-	102	39,3	116	39,5	132	39,6	139	39,7	147	39,7	192	40,0
50	-	-	-	-	115	43,6	131	43,8	137	43,8	145	43,8	188	44,0
55	-	-	-	-	-	-	129	48,5	135	48,5	142	48,5	184	48,7

<b>Outdoor fan power input (kw)</b>	
Nominal airflow	3,68

<b>TC (kW) :</b> Total cooling capacity	<b>TH (kW) :</b> Total heating capacity	<b>PI (kW) :</b> Power input
---	---	------------------------------

**COOLING CAPACITIES**

ASC 200D	Air inlet temperature at condenser (wet bulb)										
	25 °C		30 °C		35 °C		40 °C		45 °C		
	TC	PI	TC	PI	TC	PI	TC	PI	TC	PI	
Evaporating temperature °C											
0	174	52,7	170	54,6	160	59,4	148	65,3	136	72,0	
5	204	54,7	199	56,7	186	62,1	173	68,3	159	75,3	
7	218	55,1	211	57,9	197	63,4	183	69,6	168	76,6	
10	241	55,5	229	59,8	214	65,3	199	71,7	183	78,9	
15	277	58,3	261	63,3	244	69,0	227	75,5	210	83,0	

**HEATING CAPACITIES**

ASH 200D	Air inlet temperature at condenser (wet bulb)													
	-11 °C		-6 °C		-1 °C		4 °C		6 °C		8 °C		18 °C	
	TH	PI	TH	PI	TH	PI	TH	PI	TH	PI	TH	PI	TH	PI
Condensing temperature °C														
30	126	40,0	145	40,3	167	40,6	191	40,9	202	41,0	213	41,2	284	42,4
35	125	43,7	143	44,1	165	44,4	188	44,7	199	44,8	210	44,9	279	45,9
40	124	47,9	142	48,4	163	48,7	186	49,0	196	49,1	207	49,2	273	50,0
45	-	-	142	53,2	162	53,6	184	54,0	193	54,1	204	54,2	267	54,9
50	-	-	-	-	161	59,3	181,7	59,7	191	59,8	201	59,9	262	60,5
55	-	-	-	-	-	-	180	66,2	189	66,3	198	66,4	256	67,0

**COOLING CAPACITIES**

ASC 230D	Air inlet temperature at condenser (wet bulb)									
	25 °C		30 °C		35 °C		40 °C		45 °C	
	TC	PI	TC	PI	TC	PI	TC	PI	TC	PI
Evaporating temperature °C										
0	202	62,5	195	66,0	184	70,7	172	76,7	158	84,0
5	238	64,5	228	68,2	215	73,3	200	79,7	183	87,4
7	254	65,3	242	69,3	228	74,5	212	81,0	194	88,9
10	277	66,8	264	70,9	248	76,4	230	83,2	210	91,2
15	317	69,6	302	74,1	283	79,9	263	87,1	240	95,5

**HEATING CAPACITIES**

ASH 230D	Air inlet temperature at condenser (wet bulb)													
	-11 °C		-6 °C		-1 °C		4 °C		6 °C		8 °C		18 °C	
	TH	PI	TH	PI	TH	PI	TH	PI	TH	PI	TH	PI	TH	PI
Condensing temperature °C														
30	146	48,7	169	49,2	194	49,6	220	50,0	231	50,2	253	50,5	328	51,2
35	145	52,9	168	53,4	192	53,8	217	54,2	228	54,4	249	54,7	322	55,4
40	145	57,8	167	58,3	190	58,7	214	59,1	224	59,3	245	59,6	315	60,3
45	145	63,4	166	63,9	188	64,3	212	64,7	221	64,9	241	65,2	309	65,9
50	145	69,8	166	70,2	187	70,7	209	71,1	218	71,2	237	71,5	303	72,1
55	146	76,8	165	77,3	185	77,7	206	78,1	215	78,2	233	78,5	297	79,1

<b>TC (kW) :</b>	Total cooling capacity	<b>TH (kW) :</b>	Total heating capacity	<b>PI (kW) :</b>	Power input
------------------	------------------------	------------------	------------------------	------------------	-------------

**COOLING CAPACITIES  
HIGH AMBIENT APPLICATION (Non standard request)**

<b>ASC 085D</b>		Air inlet temperature at condenser (wet bulb)									
Evaporating temperature °C	46 °C		47 °C		48 °C		49 °C		50 °C		
	TC	PI	TC	PI	TC	PI	TC	PI	TC	PI	
0	57,0	32,6	55,9	33,2	54,7	33,8	53,5	34,5	52,4	35,1	
5	65,8	34,2	64,4	34,9	63,0	35,6	-				
7	69,4	34,9	68,0	35,6	-						
10	75,1	36,1	-								
15	-										

<b>ASC 100D</b>		Air inlet temperature at condenser (wet bulb)									
Evaporating temperature °C	46 °C		47 °C		48 °C		49 °C		50 °C		
	TC	PI	TC	PI	TC	PI	TC	PI	TC	PI	
0	72,11	38,52	70,69	39,27	69,19	40,08	-				
5	84,13	39,87	82,49	40,64	80,82	41,43	79,14	42,24	77,47	43,04	
7	89,12	40,47	87,39	41,25	85,68	42,02	83,9	42,83	82,13	43,64	
10	86,89	41,42	95,03	42,19	93,16	42,98	91,27	43,77	-		
15	110,48	43,18	108,41	43,93	-						

<b>ASC 120D</b>		Air inlet temperature at condenser (wet bulb)									
Evaporating temperature °C	46 °C		47 °C		48 °C		49 °C		50 °C		
	TC	PI	TC	PI	TC	PI	TC	PI	TC	PI	
0	78,88	42,37	77,29	43,22	75,67	44,10	-				
5	91,9	43,86	90,14	44,69	88,28	45,56	86,40	46,46	84,55	47,35	
7	97,38	44,50	95,51	45,33	93,54	46,21	91,61	47,09	89,63	47,99	
10	105,9	45,51	103,84	46,36	101,8	47,2	99,65	48,09	-		
15	120,89	47,34	118,56	48,18	-						

<b>ASC 140D</b>		Air inlet temperature at condenser (wet bulb)									
Evaporating temperature °C	46 °C		47 °C		48 °C		49 °C		50 °C		
	TC	PI	TC	PI	TC	PI	TC	PI	TC	PI	
0	97,85	52,04	95,92	53,09	94,02	54,14	-				
5	114,09	53,89	111,96	54,90	109,76	55,96	107,56	57,04	105,31	58,16	
7	120,96	54,69	118,73	55,70	116,40	56,77	114,07	57,85	111,77	58,95	
10	131,73	55,95	129,22	57,0	126,79	58,05	124,27	59,14	-		
15	150,68	58,31	147,92	59,35	-						

<b>ASC 200D</b>		Air inlet temperature at condenser (wet bulb)									
Evaporating temperature °C	46 °C		47 °C		48 °C		49 °C		50 °C		
	TC	PI	TC	PI	TC	PI	TC	PI	TC	PI	
0	133,5	73,5	130,9	75,0	128,2	76,5	125,6	78,0	122,9	79,5	
5	155,1	77,0	152,0	78,6	148,9	80,2	145,8	81,8	92,02	43,38	
7	164,3	78,6	161,0	80,2	157,7	81,8	99,92	43,04	98,23	43,90	
10	178,8	81,0	175,3	82,6	111,65	43,07	109,81	43,91	107,98	44,77	
15	133,90	43,03	131,86	43,82	129,75	44,66	127,72	45,50	125,63	46,39	

Values in grey cells

Derating capacity, 2 compressors unload due to high discharge temperature

<b>TC (kW) :</b>	Total cooling capacity	<b>TH (kW) :</b>	Total heating capacity	<b>PI (kW) :</b>	Power input
------------------	------------------------	------------------	------------------------	------------------	-------------

## CAPACITY STEPS

### Cooling and heating capacities

ASC/ASH		020S	025S → 040S	045D → 085D	100D	120D	140D	200D	230D
Capacity steps %	Standard	0-100 %		0-50-100 %	0-59-100 %	0-62-100 %	0-50-100 %	0-53-100 %	0-50-100 %
	Non Standard Request (NSR)	0-100 %		0-50-100 %	0-33-66 100 % <sup>(1)</sup>			0-25-50-100 <sup>(1)</sup>	

(1) : The unit balances the operation of its compressors (number of starting/operating times), capacity steps are the average of possible steps.

## CORRECTION FACTORS

To find out the performances for units installed with air ducts, apply the following coefficients on capacity and consumption data, over the performance tables of standard fan units without ducts.

### Cooling mode

		Version	Models	Available static pressure Pa	Maximum ambient temperature °C	Correction factor for cooling capacity	Correction factor for power consumption (FP1 only)
Air available static pressure up to	50 Pa	Standard	020S → 200D	30	43	0.95	1.06
				50	39	0.89	1.16
	125 Pa	FP1 Low speed	100D → 200D (230D)	50	45 (38)	0.964	1.072
				75	42 (35)	0.935	1.094
				100	38 (-)	0.9	1.174
	250 Pa	FP1 High speed	100D → 200D (230D)	125	36 (-)	0.856	1.269
				150	47 (43)	1.01	0.98
				200	44 (40)	0.97	1.037
				250	41 (37)	0.94	1.099

### Heating mode

		Version	Models	Available static pressure Pa	Maximum ambient temperature °C	Correction factor for heating capacity	Correction factor for power consumption (FP1 only)
Air available static pressure up to	50 Pa	Standard	020S → 200D	30	-9	0.94	1.02
				50	-8	0.89	1.03
	125 Pa	FP1 Low speed	100D → 200D (230D)	50	-10 (-8)	1	1
				75	-8 (-6)	0.94	1.02
				100	-6 (-)	0.89	1.03
	250 Pa	FP1 High speed	100D → 200D (230D)	125	-5 (-)	0.87	1.04
				150	-10 (-10)	1.01	0.99
				200	-10 (-8)	1	1
				250	-8 (-6)	0.94	1.02

### EXTRA POWER CONSUMPTION

#### Cooling and heating modes

MODELS	100D	120D	140D	200D	230D
FP1 Low speed	2	2	1	5.8	2
FP1 High speed	6.2	6.2	5.2	14.2	10.4

### OPERATING LIMITS

Cooling only units		Maximum temperatures	Minimum temperatures
Cooling operation	Indoor temperature	32°C DB / 23°C WB	21°C DB / 15°C WB
	Outdoor temperature	45°C (020S-025S-030S-045D-055D) 47°C (035S-040S-070D-085D-100D-120D-140D-200D-230D)	+10°C (standard unit) 0°C (*) -15°C (**)

Heat pumps		Maximum temperatures	Minimum temperatures
Cooling operation	Indoor temperature	32°C DB / 23°C WB	21°C DB / 15°C WB
	Outdoor temperature	45°C (020S-025S-030S-045D-055D) 47°C (035S-040S-070D-085D-100D-120D-140D-200D-230D)	0°C
Heating operation	Indoor temperature	27°C DB	15°C DB
	Outdoor temperature	Depending on models See heating capacities tables	-10°C DB / -11°C WB

DB : Dry bulb temperature  
WB : Wet bulb temperature

(\*) : With optional 0°C low temperature kit  
(\*\*) : With optional -15°C low temperature kit

**HOT WATER COIL**

INDOOR UNIT CIC/CIH	Capacity according to the gap between water inlet and air inlet temperature			Water flow L/H	Water coil pressure drop kPa	Air pressure drop Pa		Nr of rows	Weight Kg	Water outlet diameter
	W					Nominal airflow	Minimum airflow			
	50 °C	60 °C	70 °C							
020S	24	29	34	2100	36	20	15	2	10	3/4"
025S	29	35	41	2500	54	32	25	2	10	3/4"
030S	30	37	43	2600	57	37	25	2	10	3/4"
035S	42	51	60	3700	40	32	25	2	12	1"
040S	46	56	65	4000	47	40	31	2	16	1"
045D	50	60	71	4400	56	50	38	2	20	1"
055D	69	83	98	6000	30	31	24	2	20	1 1/4"
070D	79	96	112	6900	39	44	34	2	24	1 1/4"
085D	86	104	122	7500	46	53	41	2	30	1 1/4"
100D	129	156	183	11300	42	30	23	2	40	1 1/2"
120D	138	167	195	12100	52	35	27	2	40	1 1/2"
140D	146	175	206	12700	58	41	31	2	40	1 1/2"

**ELECTRICAL HEATER SELECTION**

INDOOR UNIT			SIZE											
			020S	025S	030S	035S	040S	045D	055D	070D	085D	100D	120D	140D
Standard	Capacity	kW	10	10	10	15	15	15	20	20	20	30	30	30
	Nr of stages		1	1	1	2	2	2	2	2	2	2	2	2
	Temperature rise	°C	8,2	6,1	5,6	6,4	5,6	4,8	5,2	4,1	3,7	4,5	4,5	4,5
Medium	Capacity	kW	15	15	15	20	20	20	27	27	27	40	40	40
	Nr of stages		2	2	2	2	2	2	2	2	2	2	2	2
	Temperature rise	°C	12,3	9,1	8,3	8,5	7,4	6,4	7	5,6	5	5,9	5,9	5,9
High heat 2 Steps	Capacity	kW	20	20	20	27	27	27	40	40	40	50	50	50
	Nr of stages		2	2	2	2	2	2	2	2	2	2	2	2
	Temperature rise	°C	16,4	12,1	11,1	11,5	10	8,7	10,4	8,3	7,5	7,4	7,9	7,4
High heat modulating	Capacity	kW	20	20	20	27	27	27	40	40	40	50	50	50
	Temperature rise	°C	16,4	12,1	11,1	11,5	10	8,7	10,4	8,3	7,5	7,4	7,4	7,4

## NOISE LEVEL OF INDOOR UNITS - IN DUCT

### STANDARD / HP1 / HP2 / HP3 UNITS

CIC/CIH		Spectrum per octave band (dB(A))								Sound power	Sound pressure 10 meters from the unit
		63 Hz	125 Hz	250	500	1000	2000	4000	8000		
		LW dB(A)									Lp dB(A)
020S	STD	-	76,6	69,8	69,1	70,0	67,5	62,9	54,6	74,2	52,2
	HP1	84,0	89,9	84,7	75,9	76,3	75,6	72,4	65,0	83,0	61,0
	HP2	86,8	91,6	86,8	77,0	77,3	76,8	73,5	66,4	84,4	62,4
	HP3	91,4	94,0	90,2	79,2	79,1	79,3	75,9	69,4	87,0	65,0
025S	STD	-	80,6	73,4	72,8	73,8	71,8	68,4	60,9	78,4	55,4
	HP1	83,1	87,0	83,0	76,7	76,3	76,3	73,5	66,8	82,9	59,9
	HP2	84,7	90,3	87,9	78,8	77,8	78,4	76,1	70,0	85,6	62,6
	HP3	90,9	93,0	93,4	82,2	80,9	81,3	79,1	74,0	89,3	66,3
030S	STD	-	81,6	74,6	74,3	75,3	73,4	70,2	63,2	79,9	54,9
	HP1	84,1	86,5	82,8	77,3	77,0	77,0	74,1	67,6	83,4	58,4
	HP2	85,9	91,1	89,6	80,3	79,0	79,7	77,7	72,2	87,0	62,0
	HP3	88,4	92,1	92,3	82,0	80,6	81,1	79,2	74,2	88,8	63,8
040S	STD	-	79,9	80,0	77,0	76,2	75,8	72,4	66,8	82,0	56,5
	HP1	84,3	86,8	82,8	82,0	78,3	78,3	76,4	70,8	85,3	59,8
	HP2	87,5	91,3	85,2	84,8	79,8	79,6	78,5	73,6	87,0	60,6
	HP3	89,6	93,7	87,3	85,9	80,8	80,3	79,6	75,0	88,6	63,1
045D	STD	-	81,3	80,8	78,4	77,4	77,1	74,2	69,0	83,3	58,3
	HP1	82,7	85,7	82,0	81,8	78,2	78,2	76,4	71,3	85,1	60,1
	HP2	85,1	89,0	84,2	84,8	80,0	79,6	78,6	73,8	87,3	62,3
	HP3	87,9	92,2	86,8	86,3	81,3	80,4	80,0	75,7	88,7	63,7
055D	STD	-	83,9	83,0	81,2	80,0	79,8	77,3	72,6	86,1	61,1
	HP1	83,8	88,3	84,1	85,2	80,8	80,8	79,6	75,0	88,0	63,0
	HP2	84,6	89,1	84,9	85,9	81,5	81,2	80,1	75,6	88,6	63,6
	HP3	87,1	91,4	86,9	87,9	83,1	82,1	81,7	77,5	90,2	65,2
070D	STD	-	79,1	79,1	75,4	74,4	74,1	70,6	64,4	80,3	53,3
	HP1	87,5	90,8	83,7	83,0	77,9	78,2	76,7	71,4	85,8	58,8
	HP2	90,2	95,4	88,4	86,0	84,3	82,2	80,9	76,7	90,2	63,2
	HP3	92,9	98,6	91,2	88,3	86,9	84,0	83,3	78,9	92,6	65,6
085D	STD	-	84,7	82,4	80,1	78,6	78,4	75,8	70,4	84,8	57,8
	HP1	86,2	89,9	85,0	85,5	80,7	80,6	79,3	74,2	88,0	61,0
	HP2	91,4	96,6	90,4	87,1	84,3	83,8	83,0	78,7	91,5	64,5
	HP3	83,3	98,7	92,2	89,0	87,4	85,0	84,8	80,8	93,5	66,5
100D	STD	-	86,5	83,7	82,6	80,3	80,2	78,0	73,0	86,7	59,7
	HP1	85,9	89,9	85,5	86,5	81,8	81,8	80,5	75,6	89,1	62,1
	HP2	91,9	96,7	90,7	88,2	86,0	85,5	84,5	80,6	92,8	65,8
	HP3	94,1	99,4	93,1	89,5	87,6	85,7	85,8	82,0	94,1	67,1
120D	STD	-	84,3	82,8	81,4	79,0	79,0	75,8	68,4	85,3	58,3
	HP1	91,0	90,4	86,6	83,5	81,3	80,5	79,0	72,6	87,8	60,8
	HP2	94,4	95,2	89,3	85,5	83,2	81,9	80,9	75,5	89,9	62,9
	HP3	96,9	98,8	92,3	87,5	84,9	83,1	82,3	77,6	91,9	64,9
140D	STD	-	85,1	84,2	83,6	81,0	81,1	78,2	70,9	87,3	60,3
	HP1	90,4	89,7	87,4	84,7	82,5	81,8	80,3	73,8	88,9	61,9
	HP2	94,0	94,6	89,9	86,4	84,2	83,0	82,0	76,4	90,7	63,7
	HP3	96,2	97,9	92,4	88,1	85,5	84,0	83,4	78,6	92,4	65,4

<b>STD</b>	Standard fan	<b>HP1</b>	High pressure fan 1 (option)
<b>HP2</b>	High pressure fan 2 (option)	<b>HP3</b>	High pressure fan 3 (option)

**NOISE LEVEL OF INDOOR UNITS - IN DUCT**
**STANDARD / HP1 / HP2 / HP3 UNITS + RETURN FAN**

CIC/CIH		Spectrum per octave band (dB(A))								Sound power	Sound pressure 10 meters from the unit
		63 Hz	125 Hz	250	500	1000	2000	4000	8000		
		LW dB(A)									Lp dB(A)
055D	STD	84,9	82,9	82,4	78,7	77,7	77,4	74,0	67,8	83,6	56,6
	HP1	88,6	91,2	85,2	83,8	79,7	79,8	77,8	72,3	87,0	60,0
	HP2	90,8	95,5	88,9	86,4	84,8	82,9	81,4	77,0	90,7	63,7
	HP3	93,2	98,7	91,5	88,5	87,2	84,5	83,6	79,1	92,9	65,9
070D	STD	87,4	86,9	85,2	82,8	81,5	81,2	78,4	73,0	87,5	60,5
	HP1	88,4	90,7	86,7	86,5	82,7	82,5	80,7	75,5	89,5	62,5
	HP2	92,2	96,8	91,0	87,8	85,3	84,8	83,6	79,2	92,2	65,2
	HP3	86,8	98,8	92,6	89,5	87,9	85,8	85,2	81,1	94,0	67,0
085D	STD	88,5	86,5	86,7	85,0	83,3	83,1	80,7	75,6	89,5	62,5
	HP1	89,0	89,9	87,7	87,6	84,1	84,0	82,2	77,2	90,9	63,9
	HP2	92,9	96,7	91,5	89,0	87,0	86,6	85,3	81,2	93,7	66,7
	HP3	94,7	99,4	93,6	90,1	88,3	86,7	86,4	82,4	94,8	67,8
100D	STD	89,8	87,4	85,9	84,4	82,0	82,0	78,9	71,5	88,3	61,3
	HP1	92,4	91,4	88,1	85,6	83,3	82,8	80,7	74,0	89,7	62,7
	HP2	95,1	95,6	90,2	86,9	84,6	83,7	82,1	76,3	91,2	64,2
	HP3	97,3	99,0	92,8	88,5	85,9	84,5	83,2	78,1	92,7	65,7
120D	STD	91,2	89,4	88,0	86,8	84,2	84,2	81,7	74,6	90,6	63,6
	HP1	92,7	91,7	89,6	87,3	85,0	84,5	82,8	76,1	91,4	64,4
	HP2	95,2	95,4	91,3	88,3	86,0	85,2	83,8	77,8	92,5	65,5
	HP3	97,0	98,3	93,2	89,5	86,9	85,8	84,8	79,5	93,7	66,7
140D	STD	92,0	90,4	89,3	88,7	86,0	85,9	83,8	77,0	92,4	65,4
	HP1	92,9	92,3	90,4	88,9	86,5	86,0	84,4	77,9	92,8	65,8
	HP2	94,8	94,8	92,0	89,6	87,3	86,5	85,2	79,1	93,7	88,6
	HP3	96,6	97,8	93,6	90,5	88,0	86,9	85,9	80,5	94,6	90,0

<b>STD</b>	Standard fan	<b>HP1</b>	High pressure fan 1 (option)
<b>HP2</b>	High pressure fan 2 (option)	<b>HP3</b>	High pressure fan 3 (option)



## NOISE LEVEL OF OUTDOOR UNITS

### STANDARD UNITS

ASC/ASH		Spectrum per octave band (dB(A))						Sound power	Sound pressure 10 meters from the unit	
		125 Hz	250	500	1000	2000	4000			8000
									LW dB(A)	Lp dB(A)
	020S	67,6	70,6	71,2	71,1	69,2	67,0	59,1	75,9	47,9
	025S	73,8	69,6	71,9	69,6	73,4	69,9	61,5	77,9	49,9
	030S	72,7	74,7	75,8	76,9	71,2	65,5	81,5	83,1	53,5
	035S	72,7	74,3	75,8	75,6	69,2	62,7	80,7	82,1	52,7
	040S	72,7	74,3	76,3	76,2	68,8	63,3	81,1	82,5	53,1
	045D	76,8	72,7	74,9	72,6	76,4	73,0	64,5	80,9	52,9
	055D	83,3	75,3	77,2	78,3	79,4	73,7	68,0	84,0	56,0
	070D	83,3	75,2	76,9	78,4	78,2	71,7	65,2	83,2	55,2
	085D	83,3	75,2	76,8	78,8	78,7	71,3	65,8	83,6	55,6
100D	Low speed	73,3	70,9	74,7	77,9	76,6	71,3	64,6	82,0	54,0
	High speed	81,9	78,4	78,9	82,6	81,9	75,8	67,0	86,9	58,9
120D	Low speed	73,3	70,9	74,5	78,4	78,2	72,3	66,1	82,9	54,9
	High speed	81,9	78,4	78,9	82,8	82,4	76,2	67,9	87,2	59,2
140D	Low speed	75,0	73,4	76,8	82,0	83,6	76,5	69,4	87,4	59,4
	High speed	84,2	80,8	80,8	85,4	86,1	79,7	71,0	90,4	62,4
200D	Low speed	76,3	74,9	78,1	82,1	83,8	75,5	66,0	87,5	59,5
	High speed	79,3	77,4	79,9	83,6	84,8	75,7	66,6	88,7	60,7
230D	Low speed	78,0	76,3	79,3	84,8	86,1	78,6	71,2	90,0	62,0
	High speed	85,2	81,8	82,0	87,0	88,0	81,2	72,5	92,1	64,1

### STANDARD UNITS + LOW NOISE OPTION

ASC/ASH		Spectrum per octave band (dB(A))						Sound power	Sound pressure 10 meters from the unit	
		125 Hz	250	500	1000	2000	4000			8000
									LW dB(A)	Lp dB(A)
	020S	67,6	70,6	71,1	70,6	68,3	65,4	58,0	75,2	47,2
	025S	73,8	69,6	69,8	66,4	71,7	67,4	61,5	75,9	47,9
	030S	72,7	73,8	74,5	74,2	66,0	65,5	79,4	80,8	51,4
	035S	72,7	73,8	74,5	73,9	65,7	62,7	79,2	80,6	51,2
	040S	72,7	73,8	74,5	74,0	65,8	63,3	79,3	80,6	51,3
	045D	76,8	72,6	72,8	69,4	74,7	70,4	64,5	78,9	50,9
	055D	83,3	75,2	76,3	77,0	76,7	68,5	68,0	81,9	53,9
	070D	83,3	75,2	76,3	77,0	76,4	68,2	65,2	81,7	53,7
	085D	83,3	75,2	76,3	77,0	76,5	68,3	65,8	81,8	53,8
100D	Low speed	73,3	70,8	72,4	75,4	71,2	62,6	64,6	78,3	50,3
	High speed	81,9	78,4	78,2	81,9	80,9	74,2	67,0	86,0	58,0
120D	Low speed	73,3	70,8	72,3	75,4	72,0	63,0	66,1	78,6	50,6
	High speed	81,9	78,4	78,2	81,9	80,9	74,2	67,9	86,0	58,0
140D	Low speed	75,0	72,6	74,1	77,2	76,1	65,5	69,4	81,2	53,2
	High speed	84,2	80,6	80,0	83,9	83,5	77,1	71,0	88,3	60,3
200D	Low speed	73,5	71,2	72,9	75,8	76,3	64,5	65,7	80,5	52,5
	High speed	79,3	76,9	78,3	81,3	80,6	68,0	66,6	85,3	57,3
230D	Low speed	78,0	75,6	77,1	80,2	78,7	68,0	71,2	84,0	56,0
	High speed	85,2	81,6	81,0	84,9	84,7	78,1	72,5	89,5	61,5

## NOISE LEVEL OF OUTDOOR UNITS

### UNITS WITH HIGH PRESSURE OPTION (FP1)

ADC/ADH		Spectrum per octave band (dB(A))							Sound power	Sound pressure 10 meters from the unit
		125 Hz	250	500	1000	2000	4000	8000		
									LW dB(A)	Lp dB(A)
100D	Low speed	84,2	80,6	80,5	84,3	81,0	74,4	68,4	87,4	59,4
	High speed	96,4	93,6	91,6	93,0	89,4	86,3	81,9	96,9	68,9
120D	Low speed	84,2	80,6	80,4	84,4	81,7	74,9	69,1	87,7	59,7
	High speed	96,4	93,6	91,6	93,1	89,5	86,3	81,9	96,9	68,9
140D	Low speed	84,2	80,8	80,8	85,4	84,9	77,7	71,0	89,6	61,6
	High speed	96,4	93,6	91,6	93,2	90,2	86,6	82,0	97,2	69,2
200D	Low speed	87,2	83,7	83,6	87,6	86,0	78,0	70,8	91,3	63,3
	High speed	99,4	96,6	94,6	96,1	92,7	89,3	84,8	100,0	72,0
230D	Low speed	87,2	83,8	83,7	88,3	87,5	80,0	73,2	92,4	64,4
	High speed	99,4	96,6	94,6	96,2	93,1	89,5	85,0	100,2	72,2

### UNITS WITH HIGH PRESSURE AND LOW NOISE OPTIONS

ADC/ADH		Spectrum per octave band (dB(A))							Sound power	Sound pressure 10 meters from the unit
		125 Hz	250	500	1000	2000	4000	8000		
									LW dB(A)	Lp dB(A)
100D	Low speed	84,2	80,6	80,0	83,8	79,7	72,0	68,4	86,6	58,6
	High speed	96,4	93,6	91,5	93,0	89,2	86,2	81,9	96,8	68,8
120D	Low speed	84,2	80,6	79,9	83,8	79,9	72,0	69,1	86,7	58,7
	High speed	96,4	93,6	91,5	93,0	89,2	86,2	81,9	96,8	68,8
140D	Low speed	84,2	80,6	80,0	83,9	80,7	72,3	71,0	87,0	59,0
	High speed	96,4	93,6	91,5	93,0	89,3	86,2	82,0	96,9	68,9
200D	Low speed	87,2	83,6	83,0	86,9	83,2	75,0	70,8	89,8	61,8
	High speed	99,4	96,6	94,5	96,0	92,3	89,2	84,8	99,9	71,9
230D	Low speed	87,2	83,6	83,0	86,9	83,6	75,2	73,2	89,9	61,9
	High speed	99,4	96,6	94,5	96,0	92,3	89,2	85,0	99,9	71,9

### EXHAUST FAN SOUND LEVEL

SIZE	020S --> 035S	040S --> 055D	070D - 085D	100D
Lw dB(A) *	64	66	73	76

## INDOOR UNITS

AIRCOOLAIR CIC - CIH		020S	025S	030S	035S	040S	045D	055D	070D	085D	100D	120D	140D
Voltage		400V/3+N/50 Hz											
Maximum absorbed power Pa	kW	0,74	1,45	1,45	1,89	2,69	2,69	2,69	3,63	5,06	5,06	6,38	6,38
Start-up current Id	A	6,44	13,0	13,0	17,3	26,4	26,4	26,4	35,6	60,2	60,2	81,0	81,0
Maximum current Ia	A	1,40	2,59	2,59	3,45	4,80	4,80	4,80	6,48	8,60	8,60	11,1	11,1

## OUTDOOR UNITS

### ELECTRICAL CONSUMPTION FOR OUTDOOR UNITS

MODELS ASC/ASH		020S	025S	030S	035S	040S	045D	055D	
Voltage		Ph/V/Hz	3N~400V 50Hz	3~400V 50Hz					
<b>Maximum absorbed power (kW)</b>									
Compressor			8,25	10,1	11,8	15,6	16,9	20,2	23,6
Fan			0,3	0,69	0,69	0,84	0,84	1,38	1,38
Total power			8,55	10,79	12,49	16,44	17,74	21,58	24,98
<b>Maximum current (A)</b>									
Compressor			15	21	22	25,6	31	42	44
Fan			1,6	3	3,4	3,4	3,4	6	6,8
Total current			16,6	24	25,4	29	34,4	48	50,8
Start up current (A)			87,5	97,4	104	138	151	121	129

MODELS ASC/ASH		070D	085D	100D	120D	140D	200D	230D	
Voltage		Ph/V/Hz	3~400V 50Hz						
<b>Maximum absorbed power (kW)</b>									
Compressor			31,1	33,8	42,6	45,6	55,9	78,8	88,2
Fan			1,68	1,68	3,05	3,05	4	4,2	8
Total power			32,78	35,48	45,65	48,65	59,9	83	96,2
<b>Maximum current (A)</b>									
Compressor			51,2	62	77,6	84	102	142	159
Fan			6,8	6,8	6,4	6,4	8	9,6	16
Total current			58	68,8	84	90,4	110	151,6	175
Start up current (A)			167	206	221	228	292	302,9	358

**OPTIONS - INDOOR UNITS**

CIC/CIH	020S		025S		030S		035S		040S		045D	
	P	FLA	P	FLA	P	FLA	P	FLA	P	FLA	P	FLA
Standard supply fan	0	0	0	0	0	0	0	0	0	0	0	0
High pressure fan HP1	0,71	1,19	0,44	0,86	0,44	0,86	0,8	1,35	0	0	0,94	1,68
High pressure fan HP2	0,71	1,19	1,24	2,21	1,24	2,21	1,74	3,03	0,94	1,68	2,37	3,80
High pressure fan HP3	1,15	2,05	1,24	2,21	2,18	3,89	1,74	3,03	2,37	3,80	2,37	3,80
Exhaust module	0,51	2,6	0,51	2,6	0,51	2,6	1,33	6,8	1,33	6,8	1,33	6,8
Return module	-	-	-	-	-	-	-	-	-	-	-	-
Electrical heater - Standard	10	14,3	10	14,3	10	14,3	15	21,5	15	21,5	15	21,5
Electrical heater - Medium	15	21,5	15	21,5	15	21,5	20	28,6	20	28,6	20	28,6
Electrical heater - High	20	28,6	20	28,6	20	28,6	27	39	27	39	27	39

CIC/CIH	055D		070D		085D		100D		120D		140D	
	P	FLA	P	FLA	P	FLA	P	FLA	P	FLA	P	FLA
Standard supply fan	0	0	0	0	0	0	0	0	0	0	0	0
High pressure fan HP1	0,94	1,68	1,43	2,12	1,32	2,5	1,32	2,5	2,41	4,2	2,41	4,2
High pressure fan HP2	2,37	3,80	2,75	4,62	3,73	6,7	5,06	8,6	3,74	6,1	3,74	6,1
High pressure fan HP3	3,69	6,3	5,16	8,82	3,73	6,7	5,06	8,6	6,38	11,1	6,38	11,1
Exhaust module	2,65	4,5	2,65	4,5	2,65	4,5	5,3	9	5,3	9	5,3	9
Return module	2,69	4,8	3,63	6,5	3,63	6,5	5,06	8,6	6,38	11,1	6,38	11,1
Electrical heater - Standard	20	28,6	20	28,6	20	28,6	27	39	27	39	27	39
Electrical heater - Medium	27	27	27	39	27	39	40	57,8	40	57,8	40	57,8
Electrical heater - High	40	40	40	57,8	40	57,8	50	72,3	50	72,3	50	72,3

<b>P</b>	Max. absorbed power in kW	<b>FLA</b>	Full load amps (A)
----------	---------------------------	------------	--------------------

**FP1 OPTION - OUTDOOR UNITS**

ASC/ASH		100D FP1	120D FP1	140D FP1	200D FP1	230D FP1
Voltage	Ph/V/Hz	3/400V/50Hz				
Maximum absorbed power Low speed / High speed	kW	2,00 / 6,20	2,00 / 6,20	1,00 / 5,2	5,8 / 14,2	2 / 10,4
Maximum current Low speed / High speed	A	3,2 / 9,8	3,2 / 9,8	1,6 / 8,2	9,6 / 22,8	3,2 / 16,4
Start up current Low speed / High speed	A	3,2 / 9,8	3,2 / 9,8	1,6 / 8,2	9,6 / 22,8	3,2 / 16,4



- Before making any electrical connections, be sure that all circuit breakers are open.
- In order to carry out the electrical connections, follow the electrical diagram supplied with the unit.

INDOOR SECTION

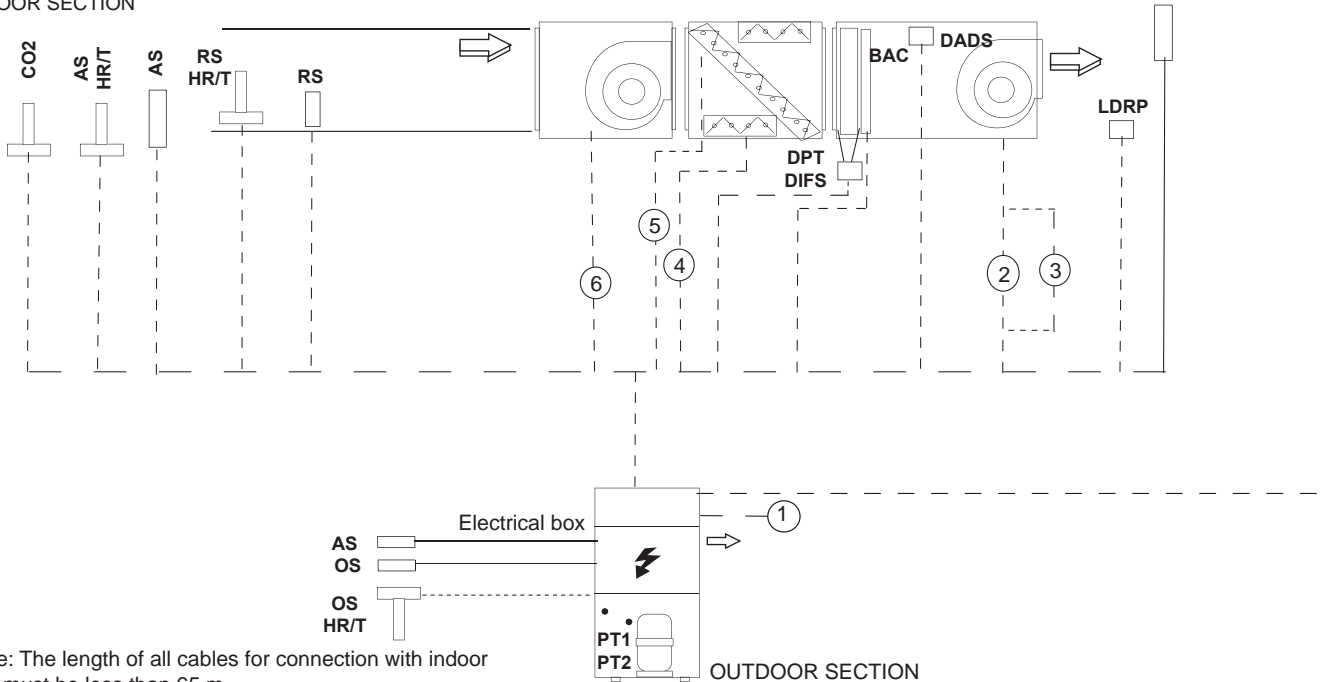

Note: The length of all cables for connection with indoor unit must be less than 65 m.

----- To be connected by installer

CONNECTION OF CONTROL ELEMENTS:

COMPONENT		Split unit	Condensing unit	
DS	Discharge sensor	STANDARD	N/A	2 x 1 mm <sup>2</sup> (shielded)
OS	Outdoor sensor		STANDARD	
AS	Remote ambient sensor			
RS	Remote duct sensor			
RS HR/T	Duct remote sensor for enthalpic free-cooling	OPTION	N/A	5 x 1 mm <sup>2</sup> (shielded)
CO2	CO2 Air quality probe. (Available only with enthalpic free-cooling)			4 x 1 mm <sup>2</sup> (shielded)
DPT	Air differential pressure transducer			3 x 1 mm <sup>2</sup> (shielded)
OS HR/T	Outdoor sensor for enthalpic free-cooling			5 x 1 mm <sup>2</sup> (shielded)
AS HR/T	Remote ambient sensor for enthalpic free-cooling			5 x 1 mm <sup>2</sup> (shielded)
DIFS	Dirty filter sensor			2 x 1,5 mm <sup>2</sup>
LDRP	Long distance connection			3 x 1,5 mm <sup>2</sup> (1 circuit units) 2 x (3 x 1,5 mm <sup>2</sup> ) (2 circuits units)
DADS	Smoke detector			7 x 1,5 mm <sup>2</sup>
BAC	Hot water coil		5 x 1,5 mm <sup>2</sup>	

VOLTAGE OPERATING LIMITS: 342-462V

**POWER SUPPLY**

	Power supply					
	Power supply	Power supply with electrical heater	Fan	Free-cooling	Exhaust fan	Return fan
	1	1'	2	4	5	6
020S	4 x 4 mm <sup>2</sup>	4 x 10 mm <sup>2</sup>	4 x 1,5 mm <sup>2</sup>	7 x 1,5 mm <sup>2</sup>	3 x 1,5 mm <sup>2</sup>	N/A
025S	4 x 6 mm <sup>2</sup>	4 x 16 mm <sup>2</sup>	4 x 1,5 mm <sup>2</sup>	7 x 1,5 mm <sup>2</sup>	3 x 1,5 mm <sup>2</sup>	N/A
030S						
035S	4 x 6 mm <sup>2</sup>	3 x 25 mm <sup>2</sup> + 1 x 16 mm <sup>2</sup>	4 x 1,5 mm <sup>2</sup>	7 x 1,5 mm <sup>2</sup>	3 x 1,5 mm <sup>2</sup>	N/A
040S	4 x 10 mm <sup>2</sup>	3 x 25 mm <sup>2</sup> + 1 x 16 mm <sup>2</sup>	4 x 1,5 mm <sup>2</sup>	7 x 1,5 mm <sup>2</sup>	3 x 1,5 mm <sup>2</sup>	N/A
045S	4 x 16 mm <sup>2</sup>	3 x 35 mm <sup>2</sup> + 1 x 16 mm <sup>2</sup>	4 x 1,5 mm <sup>2</sup>	7 x 1,5 mm <sup>2</sup>	3 x 1,5 mm <sup>2</sup>	N/A
055D	4 x 16 mm <sup>2</sup>	3 x 50 mm <sup>2</sup> + 1 x 25 mm <sup>2</sup>	4 x 1,5 mm <sup>2</sup> (STD/HP1) 4 x 2,5 mm <sup>2</sup> (HP2/HP3)	7 x 1,5 mm <sup>2</sup>	4 x 1,5 mm <sup>2</sup>	4 x 1,5 mm <sup>2</sup>
070D	3 x 25 mm <sup>2</sup> + 1 x 16 mm <sup>2</sup>	3 x 70 mm <sup>2</sup> + 1 x 35 mm <sup>2</sup>	4 x 1,5 mm <sup>2</sup> (STD/HP1) 4 x 2,5 mm <sup>2</sup> (HP2/HP3)	7 x 1,5 mm <sup>2</sup>	4 x 1,5 mm <sup>2</sup>	4 x 1,5 mm <sup>2</sup>
085D						
100D	3 x 35 mm <sup>2</sup> + 1 x 16 mm <sup>2</sup>	3 x 95 mm <sup>2</sup> + 1 x 50 mm <sup>2</sup>	4 x 2,5 mm <sup>2</sup> (STD/HP1) 2 x (4 x 1,5 mm <sup>2</sup> ) (HP2/HP3)	7 x 1,5 mm <sup>2</sup>	4 x 1,5 mm <sup>2</sup>	4 x 2,5 mm <sup>2</sup>
120D	3 x 35 mm <sup>2</sup> + 1 x 16 mm <sup>2</sup>	3 x 95 mm <sup>2</sup> + 1 x 50 mm <sup>2</sup>	4 x 2,5 mm <sup>2</sup> (STD/HP1) 2 x (4 x 2,5 mm <sup>2</sup> ) (HP2/HP3)	7 x 1,5 mm <sup>2</sup>	4 x 1,5 mm <sup>2</sup>	4 x 2,5 mm <sup>2</sup>
140D	3 x 50 mm <sup>2</sup> + 1 x 25 mm <sup>2</sup>	3 x 95 mm <sup>2</sup> + 1 x 50 mm <sup>2</sup>	4 x 2,5 mm <sup>2</sup> (STD/HP1) 2 x (4 x 2,5 mm <sup>2</sup> ) (HP2/HP3)	7 x 1,5 mm <sup>2</sup>	4 x 1,5 mm <sup>2</sup>	4 x 2,5 mm <sup>2</sup>
200D	3 x 70 mm <sup>2</sup> + 1 x 25 mm <sup>2</sup>	N/A	N/A	N/A	N/A	N/A
230D	3 x 95 mm <sup>2</sup> + 1 x 25 mm <sup>2</sup>	N/A	N/A	N/A	N/A	N/A

	Power supply			
	Electrical heater (3)			
	Standard	Medium	High	Modulating
020S	4 x 2,5 mm <sup>2</sup> + 6 x 1,5 mm <sup>2</sup>	4 x 4 mm <sup>2</sup> + 6 x 1,5 mm <sup>2</sup>	4 x 6 mm <sup>2</sup> + 6 x 1,5 mm <sup>2</sup>	4 x 6 mm <sup>2</sup> + 7 x 1,5 mm <sup>2</sup>
025S	4 x 2,5 mm <sup>2</sup> + 6 x 1,5 mm <sup>2</sup>	4 x 4 mm <sup>2</sup> + 6 x 1,5 mm <sup>2</sup>	4 x 6 mm <sup>2</sup> + 6 x 1,5 mm <sup>2</sup>	4 x 6 mm <sup>2</sup> + 7 x 1,5 mm <sup>2</sup>
030S	4 x 2,5 mm <sup>2</sup> + 6 x 1,5 mm <sup>2</sup>	4 x 4 mm <sup>2</sup> + 6 x 1,5 mm <sup>2</sup>	4 x 6 mm <sup>2</sup> + 6 x 1,5 mm <sup>2</sup>	4 x 6 mm <sup>2</sup> + 7 x 1,5 mm <sup>2</sup>
035S	4 x 4 mm <sup>2</sup> + 6 x 1,5 mm <sup>2</sup>	4 x 6 mm <sup>2</sup> + 6 x 1,5 mm <sup>2</sup>	4 x 10 mm <sup>2</sup> + 6 x 1,5 mm <sup>2</sup>	4 x 10 mm <sup>2</sup> + 7 x 1,5 mm <sup>2</sup>
040S	4 x 4 mm <sup>2</sup> + 6 x 1,5 mm <sup>2</sup>	4 x 6 mm <sup>2</sup> + 6 x 1,5 mm <sup>2</sup>	4 x 10 mm <sup>2</sup> + 6 x 1,5 mm <sup>2</sup>	4 x 10 mm <sup>2</sup> + 7 x 1,5 mm <sup>2</sup>
045S	4 x 4 mm <sup>2</sup> + 6 x 1,5 mm <sup>2</sup>	4 x 6 mm <sup>2</sup> + 6 x 1,5 mm <sup>2</sup>	4 x 10 mm <sup>2</sup> + 6 x 1,5 mm <sup>2</sup>	4 x 10 mm <sup>2</sup> + 7 x 1,5 mm <sup>2</sup>
055D	4 x 6 mm <sup>2</sup> + 6 x 1,5 mm <sup>2</sup>	3 x 10 mm <sup>2</sup> +PE + 6 x 1,5 mm <sup>2</sup>	4 x 16 mm <sup>2</sup> + 6 x 1,5 mm <sup>2</sup>	4 x 16 mm <sup>2</sup> + 7 x 1,5 mm <sup>2</sup>
070D	4 x 6 mm <sup>2</sup> + 6 x 1,5 mm <sup>2</sup>	3 x 10 mm <sup>2</sup> +PE + 6 x 1,5 mm <sup>2</sup>	4 x 16 mm <sup>2</sup> + 6 x 1,5 mm <sup>2</sup>	4 x 16 mm <sup>2</sup> + 7 x 1,5 mm <sup>2</sup>
085D	4 x 6 mm <sup>2</sup> + 6 x 1,5 mm <sup>2</sup>	3 x 10 mm <sup>2</sup> +PE + 6 x 1,5 mm <sup>2</sup>	4 x 16 mm <sup>2</sup> + 6 x 1,5 mm <sup>2</sup>	4 x 16 mm <sup>2</sup> + 7 x 1,5 mm <sup>2</sup>
100D	4 x 10 mm <sup>2</sup> + 6 x 1,5 mm <sup>2</sup>	4 x 16 mm <sup>2</sup> + 6 x 1,5 mm <sup>2</sup>	4 x 25 mm <sup>2</sup> + 6 x 1,5 mm <sup>2</sup>	4 x 25 mm <sup>2</sup> + 7 x 1,5 mm <sup>2</sup>
120D	4 x 10 mm <sup>2</sup> + 6 x 1,5 mm <sup>2</sup>	4 x 16 mm <sup>2</sup> + 6 x 1,5 mm <sup>2</sup>	4 x 25 mm <sup>2</sup> + 6 x 1,5 mm <sup>2</sup>	4 x 25 mm <sup>2</sup> + 7 x 1,5 mm <sup>2</sup>
140D	4 x 10 mm <sup>2</sup> + 6 x 1,5 mm <sup>2</sup>	4 x 16 mm <sup>2</sup> + 6 x 1,5 mm <sup>2</sup>	4 x 25 mm <sup>2</sup> + 6 x 1,5 mm <sup>2</sup>	4 x 25 mm <sup>2</sup> + 7 x 1,5 mm <sup>2</sup>
200D	N/A	N/A	N/A	N/A
230D	N/A	N/A	N/A	N/A

n/a: not available

<b>STD</b>	Standard fan	<b>HP1</b>	High pressure fan 1 (option)
<b>HP2</b>	High pressure fan 2 (option)	<b>HP3</b>	High pressure fan 3 (option)

COMFORT AND SERVICE TERMINAL CONNECTION

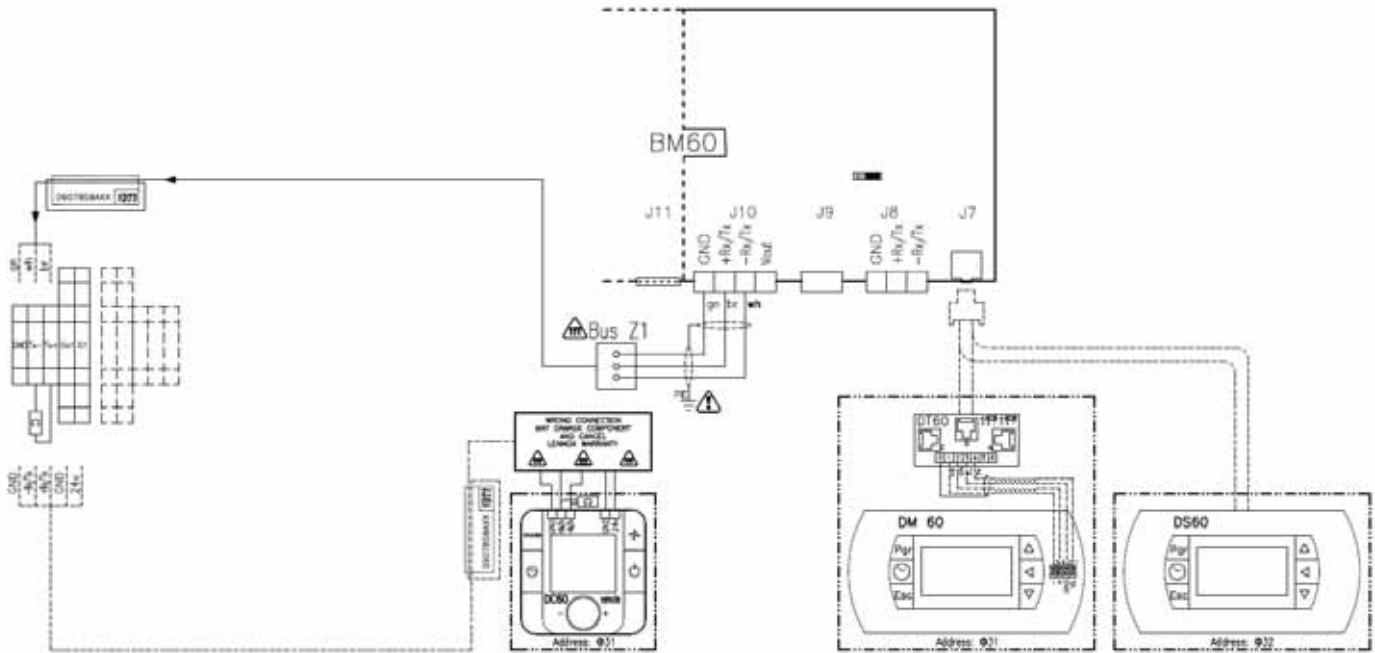

DRY CONTACT BOARD CONTROL

The AIRCOOLAIR condensing unit can be remotely controlled via dry contacts on the BM60 and BE60. The expansion board BE60 is an additional board fixed on DIN rail. This board is supplied in stand on AIRCOOLAIR condensing unit.

Description of the various connectors :

- 1 Power supply of the board
- 2 Analog output 0/10V : not used
- 3 Network bus to the CLIMATIC 60 BM60
- 4 4 digital inputs : dry contacts only
- 5 LED status of the network bus
- 6 Serial address dip-switch of the network bus
- 7 4 analog input configurable by pair B1-B2 and B3-B4
- 8 4 digital outputs : dry contact only

6 digital inputs are dry contacts. They are factory configured as follow :

**2 inputs on the BM60**

- BM-J4-ID4 : TCB B = Cooling/Heating - Contact closed = the unit operates in heating mode and open contact = the unit operates in cooling mode
- BM-J4-ID7 : TCB G = On/Off - Contact closed = On.

**4 inputs on the BE60**

Size	Standard		Non standard request (NSR)			
	020 → 040	045 → 230D	020 - 040	045D-085D	100D-140D	200D-230D
<b>BE-J4-ID1 : TCB Y1</b>	100 %	50 %	100 %	50 %	33 %	25 %
<b>BE-J4-ID2 : TCB Y2</b>	Available	100 %	Available	100 %	66 %	50 %
<b>BE-J4-ID3</b>		Available		100 %	75 %	
<b>BE-J4-ID4</b>				Available	100 %	

**INDOOR UNITS - CIC/CIH**

**MODELS 020S-025S-030S**

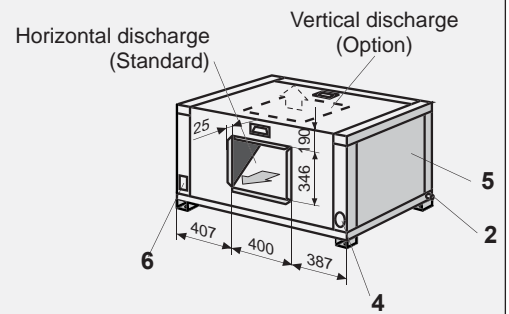
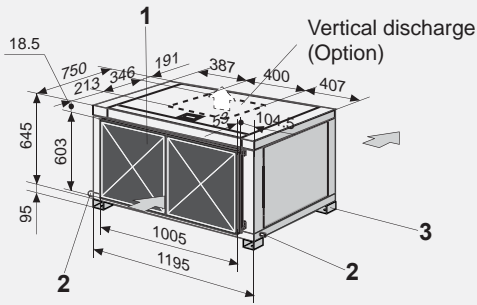

**MODELS 035S-040S-045D**

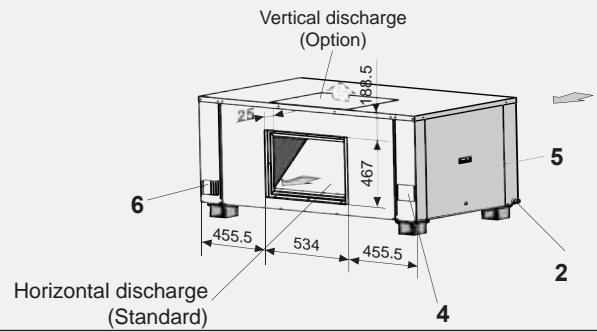
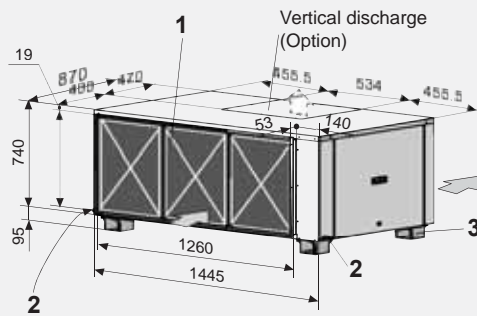

**MODELS 055D-070D-085D**

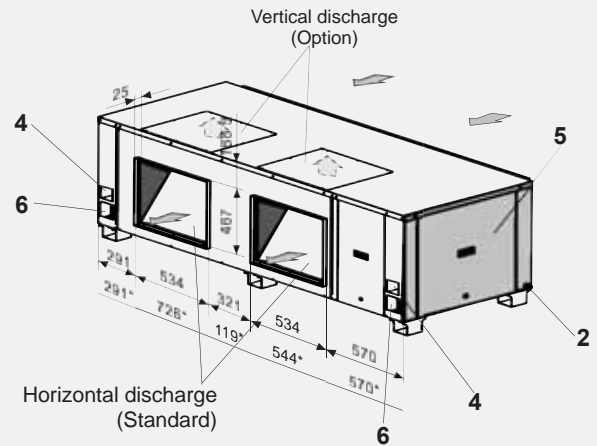
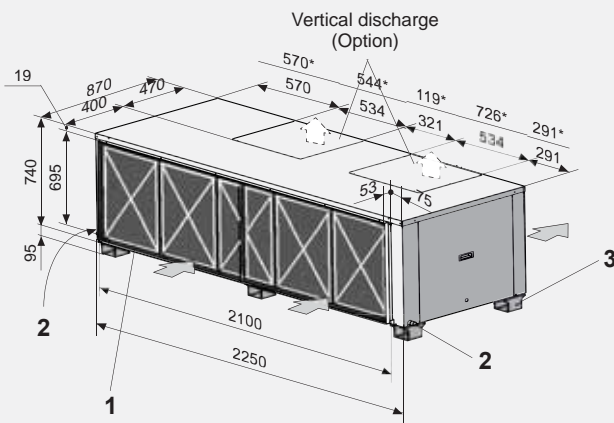

\* Values with HP2 and HP3 options.

**MODELS 100D-120D-140D**

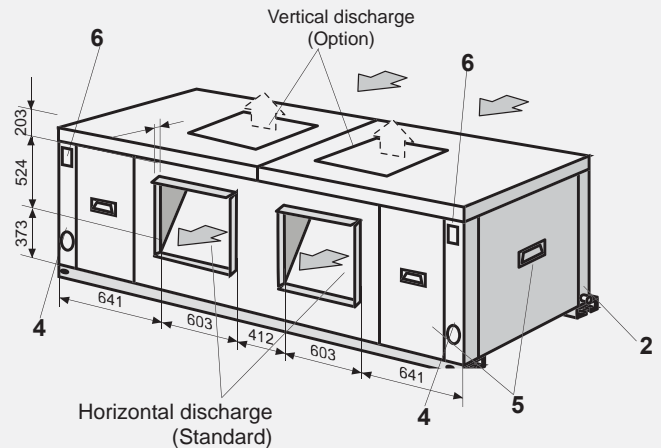
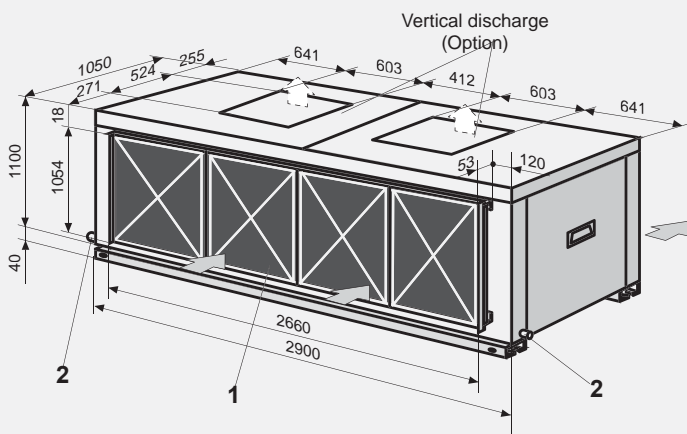

<b>1</b>	Air filter	<b>3</b>	Transportation support	<b>5</b>	Access to motor
<b>2</b>	Drainage outside thread 3/4»	<b>4</b>	Electrical power supply	<b>6</b>	Refrigerant connection



**OUTDOOR UNITS - ASC/ASH**

020S

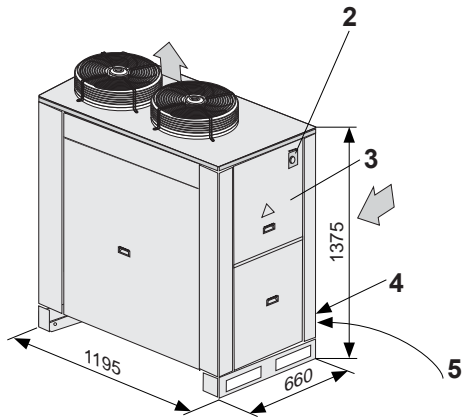

025S/030S/035S/040S

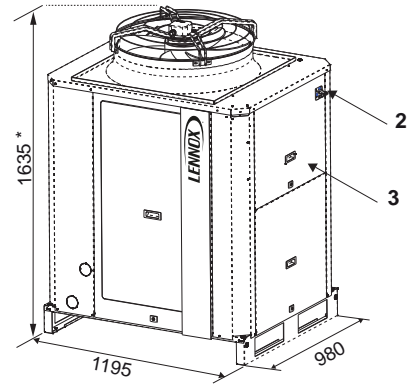

045D/055D/070D/085D

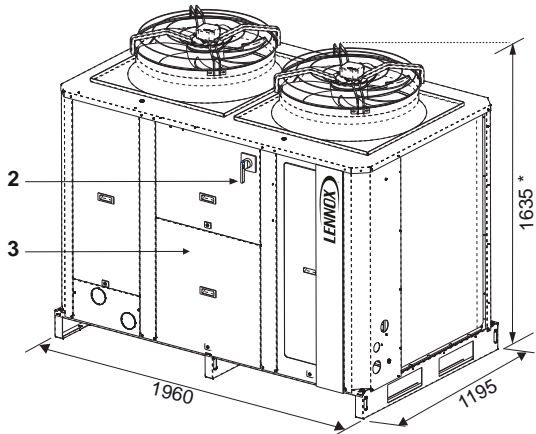

100D/120D/140D

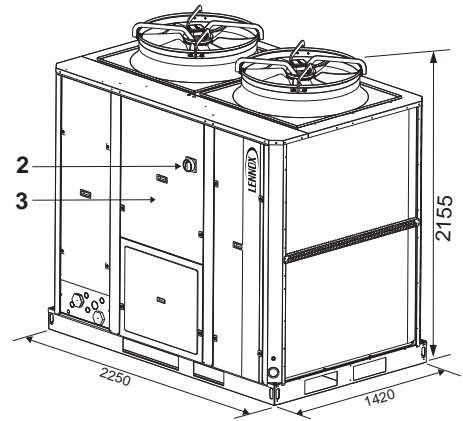

200D - 230D

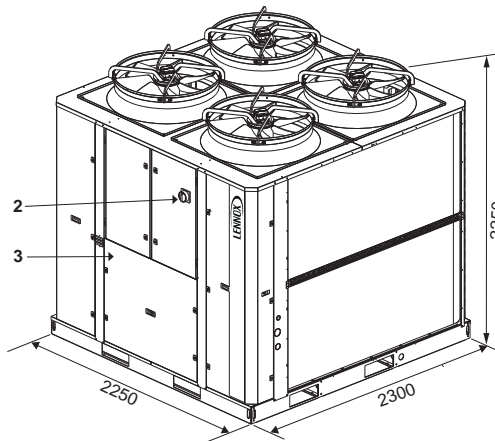

2	Main switch (option)	4	Power supply cable entry
3	Electrical box	5	Access to gas and liquid lines

**ECONOMIZER + EXHAUST FANS**

**A BOX & B BOX**

020S/025S/030S/035S/040S/045D

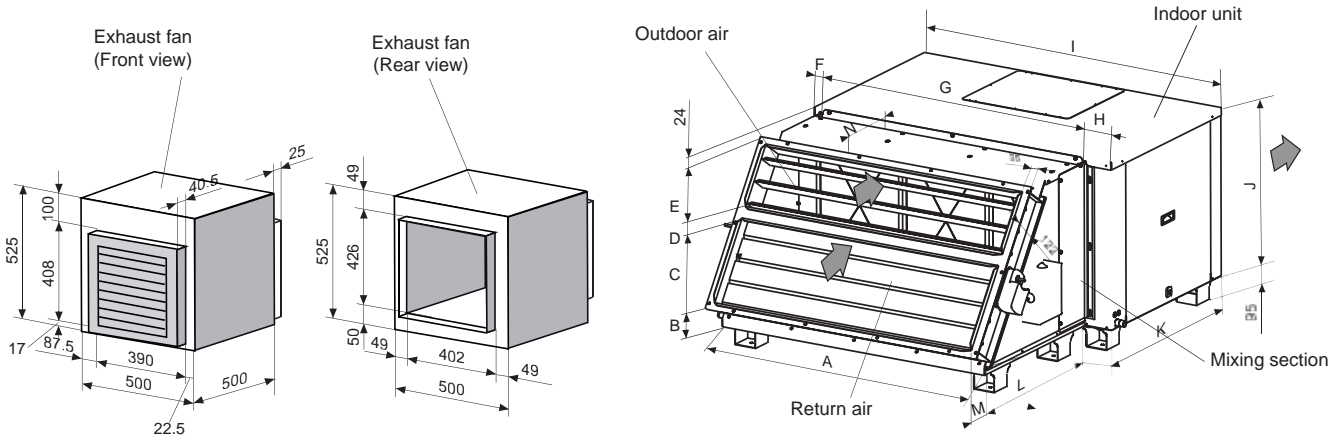

The damper position may be different from that shown in the illustration. See drawings.

SIZE	A	B	C	D	E	F	G	H	I	J	K	L	M	N
020S-030S	1000	148,5	291	38,5	138	74,5	1027	92,5	1194	640	749	789,5	100	307
035S-045D	1250	129,3	311,3	41	229,4	34	1282	129	1445	735	870	791	110	314

**C BOX**

055D/070D/085D

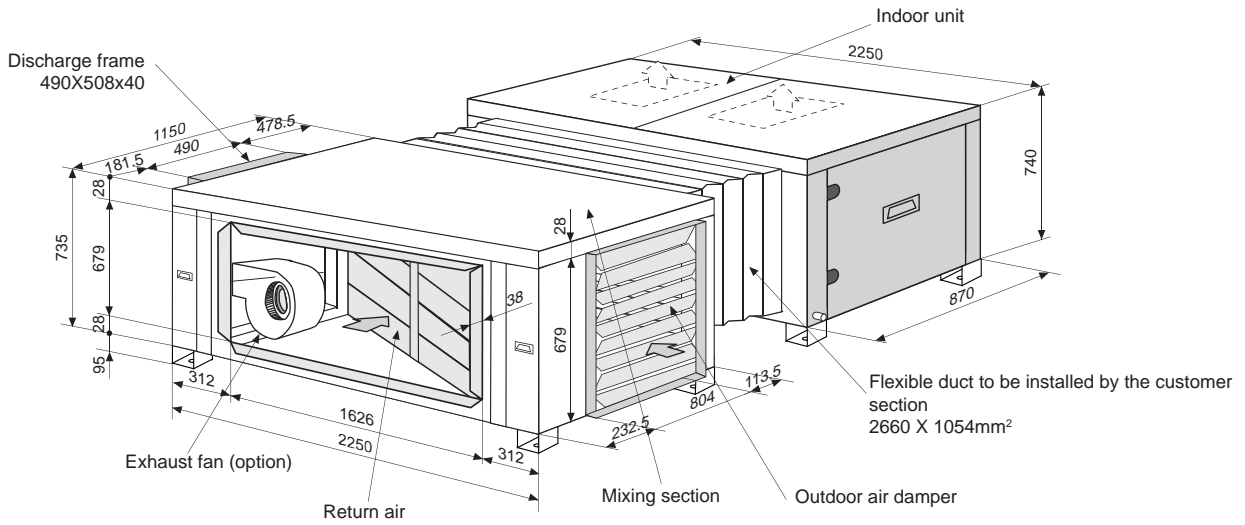

**D BOX**

100D/120D/140D

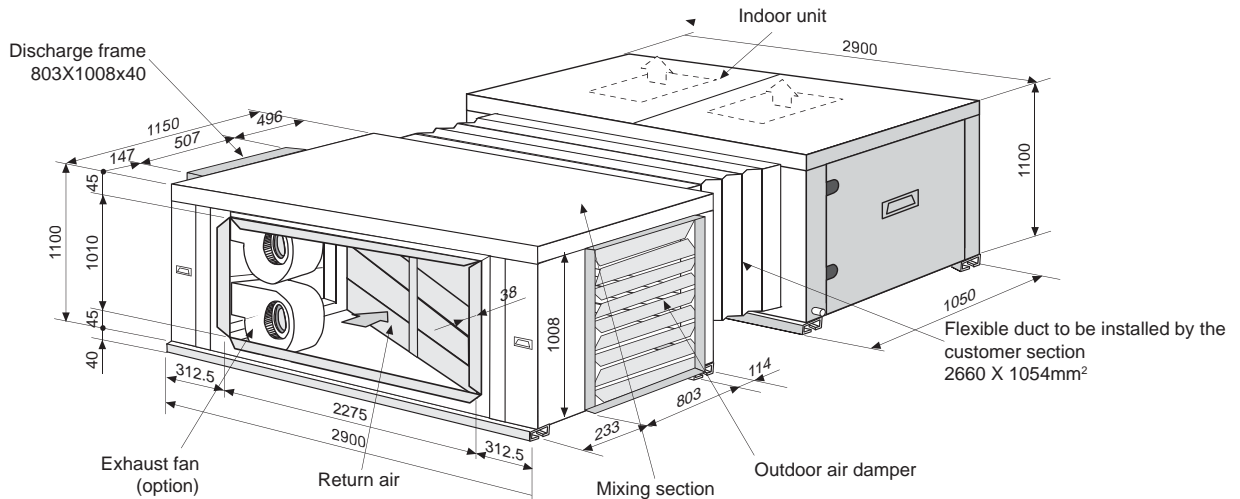

It is possible to include an exhaust fan with free cooling without return fan.

### UNITS WITH HIGH PRESSURE FANS

This option is available only for outdoor units, sizes 100D, 120D and 140D.  
Available static pressure up to 250 Pa.

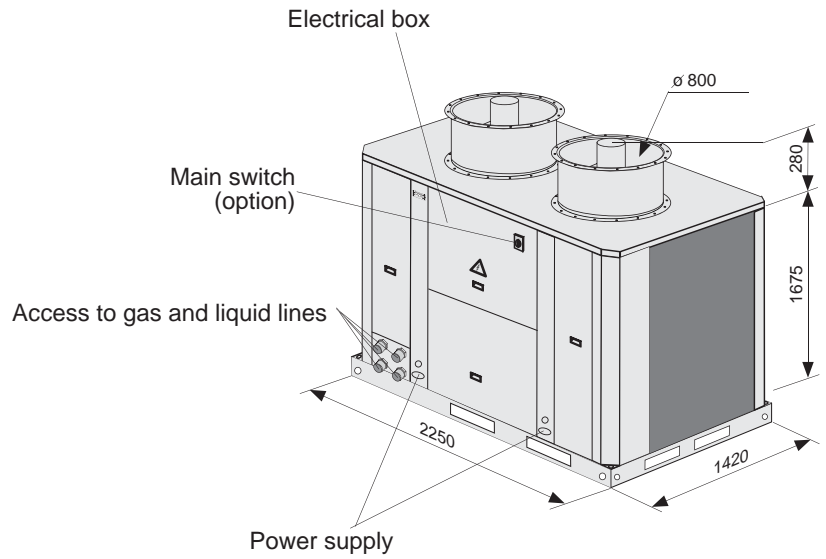

### RETURN FAN MODULE

#### 055D/070D/085D/100D

MODELS	055D/070D/085D	100D/120D/140D
A	2250	2571
B	28	45
C	28	45
D	650	700
E	1626	2275
F	312	148
G	312	148
H	735	1100
I	679	1010
J	95	40

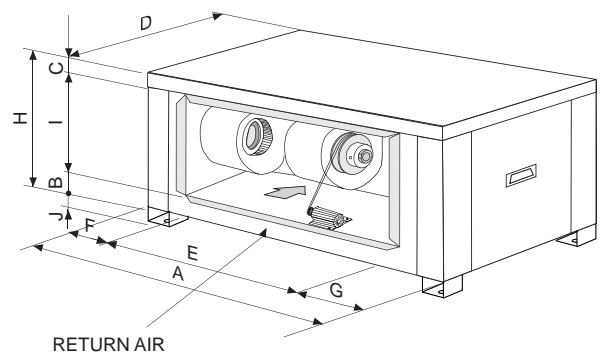

### CLEARANCES

Space should be left free for access or servicing, to ease the installation of cables, drainage connections, electric installation and cleaning filters, as well as easy access to the unit.

#### OUTDOOR UNITS - ASC/ASH

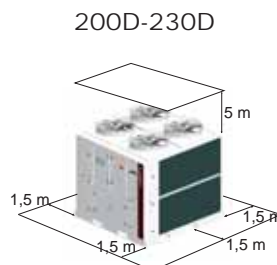
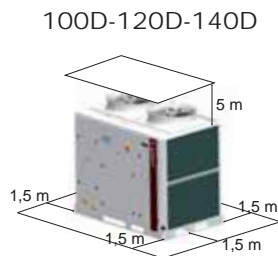
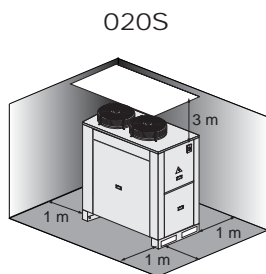

#### Indoor units CIC/CIH

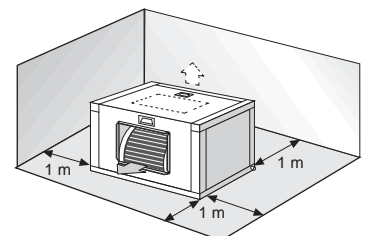

**OUTDOOR UNIT**

AIRCOOLAIR - ASC/ASH		020S	025S	030S	035S	040S	045D	055D
<b>ASC</b> Cooling only	kg	160	210	216	233	255	443	452
<b>ASH</b> Heat pump		168	219	221	239	258	452	463
Soft starter		3	3	3	3	3	6	6
FP1 option		-	-	-	-	-	-	-
AIRCOOLAIR - ASC/ASH		070D	085D	100D	120D	140D	200D	230D
<b>ASC</b> Cooling only	kg	481	520	632	797	906	...	...
<b>ASH</b> Heat pump		499	537	748	828	932	1684	1704
Soft starter		6	6	9	9	9	...	...
FP1 option		-	-	40	40	40	...	...

Operating weights

**INDOOR UNITS**

AIRCOOLAIR - CIC/CIH		020S	025S	030S	035S	040S	045D	
Air treatment section	kg	108	111	115	150	160	170	
Air sock control		2	2	2	2	2	2	
Electrical heater		10	10	10	10	10	20	
Economizer		50	50	50	75	75	75	
Hot water coil		10	10	10	12	16	20	
High pressure fan motor indoor		HP1	6.5	3	3	5	0	3
		HP2	6,5	3	8	8	3	6
		HP3	9,5	8	11	8	6	6
Exhaust fan		25	25	25	28	28	28	
High filtration level G4 prefilter / F7 filtration		6	6	6	9	9	9	
AIRCOOLAIR - CIC/CIH		055D	070D	085D	100D	120D	140D	
Air treatment section	kg	242	259	276	470	480	490	
Air sock control		2	3	3	3	3	3	
Electrical heater		20	20	30	45	45	45	
Economizer		165	165	165	190	190	190	
Hot water coil		20	24	30	40	40	40	
High pressure fan motor indoor		HP1	3	3	13	13	8	8
		HP2	6	16	21	27	14	14
		HP3	19	24	21	27	40	40
Exhaust fan		37	37	37	65	65	65	
High filtration level G4 prefilter / F7 filtration		14	14	14	23	23	23	

Operating weights

To locate the outdoor and the indoor units, refer to the following information :

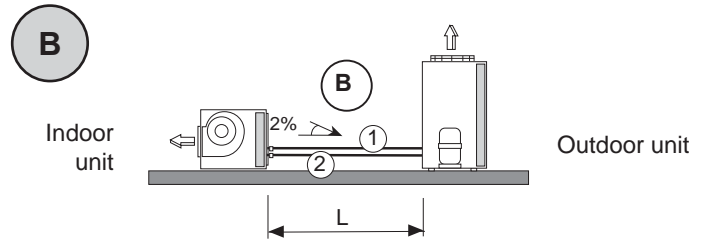
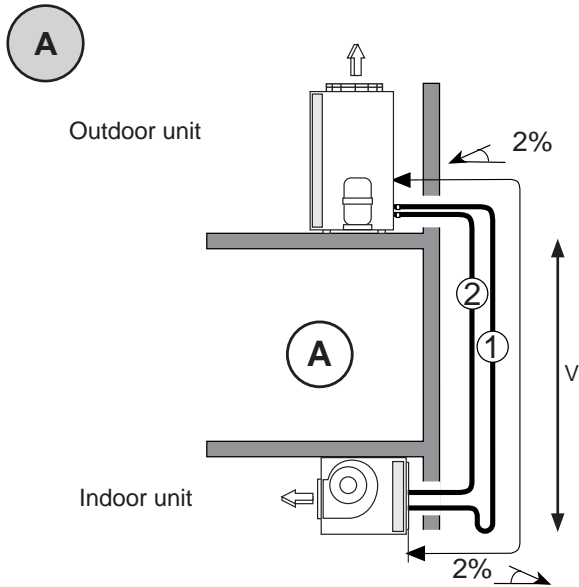

As standard, distance between indoor and outdoor units is 40 meters. This distance reaches 65 meters with long distance option.

V : Maximum length = 16 meters

L : Maximum total length (vertical + horizontal = 65 meters)

1	Circuit 1
2	Circuit 2

**REFRIGERANT LINES SELECTION**

REFRIGERANT LINES				Sizes							
				020S	025S	030S	035S	040S	045D	055D	
Total line length. (Length refrigerant lines between indoor unit and outdoor unit.)	0 to 30 m. (Standard connection of unit)	Ø Liquid	C1	1/2"	5/8"	5/8"	5/8"	5/8"	5/8"	5/8"	5/8"
			C2	n/a	n/a	n/a	n/a	n/a	5/8"	5/8"	
		Ø Gas	C1	7/8"	1 1/8"	1 1/8"	1 3/8"	1 3/8"	1 1/8"	1 1/8"	
			C2	n/a	n/a	n/a	n/a	n/a	1 1/8"	1 1/8"	
	Max. nr of bends			6	12	8	18	12	12	8	
	30 to 65 m.	Ø Liquid	C1	5/8"	5/8"	5/8"	3/4"	3/4"	5/8"	5/8"	
			C2	n/a	n/a	n/a	n/a	n/a	5/8"	5/8"	
		Ø Gas	C1	1 1/8"	1 1/8"	1 3/8"	1 3/8"	1 5/8"	1 1/8"	1 3/8"	
			C2	n/a	n/a	n/a	n/a	n/a	1 1/8"	1 3/8"	
	Max. nr of bends			12	18	18	18	18	18	18	
				070D	085D	100D	120D	140D	200D	230D	
Total line length. (Length refrigerant lines between indoor unit and outdoor unit.)	0 to 30 m. (Standard connection of unit)	Ø Liquid	C1	5/8"	5/8"	3/4"	3/4"	3/4"	7/8"	7/8"	
			C2	5/8"	5/8"	5/8"	5/8"	3/4"	7/8"	7/8"	
		Ø Gas	C1	1 3/8"	1 3/8"	1 5/8"	1 5/8"	1 5/8"	1 5/8"	2 1/8"	
			C2	1 3/8"	1 3/8"	1 3/8"	1 3/8"	1 5/8"	1 5/8"	2 1/8"	
	Max. nr of bends			18	12	12	12	12	12	12	
	30 to 65 m.	Ø Liquid	C1	3/4"	3/4"	7/8"	7/8"	7/8"	n/a	n/a	
			C2	3/4"	3/4"	3/4"	3/4"	7/8"	n/a	n/a	
		Ø Gas	C1	1 3/8"	1 5/8"	1 5/8"	1 5/8"	1 5/8"	n/a	n/a	
			C2	1 3/8"	1 5/8"	1 5/8"	1 5/8"	1 5/8"	n/a	n/a	
	Max. nr of bends			18	18	12	12	12	n/a	n/a	

n/a: not available



lennoxemeia.com

SALES OFFICES :

BELGIUM AND LUXEMBOURG

+ 32 3 633 3045

FRANCE

+33 1 64 76 23 23

GERMANY

+49 (0) 211 950 79 600

ITALY

+ 39 02 495 26 200

NETHERLANDS

+ 31 332 471 800

POLAND

+48 22 58 48 610

PORTUGAL

+351 229 066 050

RUSSIA

+7 495 626 56 53

SPAIN

+34 915 401 810

UKRAINE

+38 044 585 59 10

UNITED KINGDOM AND IRELAND

+44 1604 669 100

OTHER COUNTRIES :

LENNOX DISTRIBUTION

+33 4 72 23 20 20



Due to Lennox's ongoing commitment to quality, the specifications, ratings and dimensions are subject to change without notice and without incurring liability. Improper installation, adjustment, alteration, service or maintenance can cause property damage or personal injury. Installation and service must be performed by a qualified installer and servicing agency