

# APPLICATION GUIDE



VERTICAL PACKAGED AIR CONDITIONER

# COMPACTAIR

20 - 100 kW

COMPACTAIR-AGU-1706-E



[www.lennoxemea.com](http://www.lennoxemea.com)



**LENNOX**



# COMPACTAIR

## APPLICATION GUIDE

Ref : COMPACTAIR-AGU-1706-E

<b>1. GENERAL DESCRIPTION</b>	
Model number description	2
Features and benefits	3
Options	8
<b>2. GENERAL DATA</b>	
General data	12
Selection procedure	15
<b>3. VENTILATION DATA</b>	
Treatment ventilation data	16
Return ventilation data	18
Option pressure drops	19
Condenser ventilation data	20
<b>4. PERFORMANCES</b>	
Cooling and heating capacities	21
Auxiliary heaters	31
<b>5. ACOUSTIC DATA</b>	
Indoor and outdoor noise level - In duct	32
Radiated noise level	33
<b>6. REFRIGERANT CONNECTIONS</b>	35
<b>7. ELECTRICAL DATA</b>	
Units electrical data	37
Options electrical data	38
Electrical connections	39
<b>8. DIMENSIONAL DATA</b>	
Units	44
Economizer + Exhaust fans	48
<b>9. WEIGHT DATA</b>	50
<b>10. AIRFLOW CONFIGURATIONS</b>	51

Our products comply with the European standards,



Product designed and manufactured under quality management systems certified ISO 9001 and ISO 14001.



All the technical and technological information contained in this manual, including any drawing and technical descriptions provided by us, remain the property of Lennox and must not be utilised (except in operation of this product), reproduced, issued to or made available to third parties without the prior written agreement of Lennox.

**UNIT CONFIGURATIONS**

COMPACTAIR		20S	25S	30S	35S	40S	45D	55D	70D	85D	100D
Packaged	<b>CMC / CMH</b>										
Split	<b>CSC/CSH - CIC/CIH</b>										

**MODEL NUMBER DESCRIPTION**

<b>C</b>	C =	<b>COMPACTAIR</b>
	-	1st letter
<b>M</b>	I =	Air treatment section
	M =	Packaged unit
	S =	Thermodynamic section
<b>C</b>	C =	Cooling
	H =	Heat pump
<b>024</b>	Cooling capacity	
<b>S</b>	S =	1 circuit
	D =	2 circuits
<b>N</b>	N =	Without refrigerant
<b>M</b>	M =	R410A
<b>1</b>	Revision number	
<b>M</b>	T =	230V/1/50
	M =	400V/3/50

**CMC  
CMH**

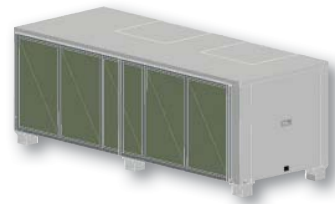
**CIC  
CIH**

**CSC  
CSH**

## APPLICATION

### Introduction

COMPACTAIR is an AIR to AIR packaged air conditioner unit for indoor installation, sheltered from bad weather conditions. Its particular "cupboard" design is made for comfort cooling & heating of medium to large volume premises (200 to 1000m<sup>2</sup> per unit) in urban environments, where installation on the roof is too complex.

COMPACTAIR is designed to be installed indoor with duct connections:

- from the thermodynamic section to the outdoor
- from the air treatment section to the premises to be air conditioned.

The COMPACTAIR range has been designed to be flexible for our customers, it can either be a simple unit when first cost is the main driver, but many options can be added to make the COMPACTAIR a premium product.

### Adaptable product:

- 20 to 100 kW cooling and heating capacity available in 4 different boxes
- Cooling only or reversible heat pump unit, that can be completed by auxiliary heating capabilities
- Variable supply airflow from 3150m<sup>3</sup>/h to 22450 m<sup>3</sup>/h and up to 600 Pa (External Static Pressure)
- Variable external static pressure up to 300 Pa at the condenser section to adapt to wide possibilities of ductwork (see page 17 to 21)
- Many versions and airflow configurations to adapt to site configuration and optimize ductwork
- Packaged and Split configurations for high adaptability to site construction
- Up to 65 m. distance between air treatment section and thermodynamic section on split version.

### Preserving architecture

COMPACTAIR is a ductable unit made for indoor installation: the only elements appearing outdoor are protection grills beyond duct connections. In many city centres, historical protection requires the preservation of building architecture. Having no HVAC machinery elements on the external building fronts protects the original architecture.

Grills are flexible elements that can be highly integrated in the environment.

### Commercial footprint requirement minimized

Estate surface in urban areas can be rare and expensive. The compact vertical design of COMPACTAIR minimises the occupied footprint, to preserve the available surface for commercial activity. For the COMPACTAIR to be the market leader in efficiency on footprint it uses bended coils.

### Easy installation

The vertical design of the COMPACTAIR ensures it fits through most door openings and standard urban room height. The maximum height of the packaged version is limited between 2,05 m and 2,15 m: the availability of the packaged version is between 20 to 87 kW facilitating the installation, limiting the handling and ductwork.

Many airflow configurations are available to adapt to most premises characteristics.

Economizer (size 020 to 045) and filter frames are optional elements delivered fixed to the base unit to ease handling and installation.

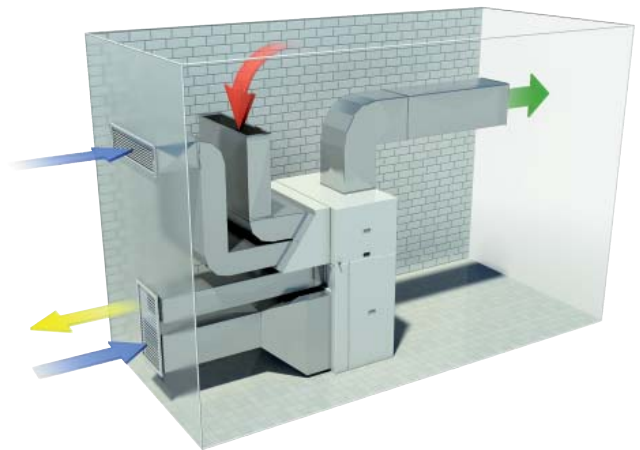

## ENERGY SAVINGS

### Economizer :

In many retail and light commercial applications, internal heat loads (lights, customers, white goods...) have to be covered 12 months a year, even in winter. The economizer module uses the external air input for cooling operations as soon as the outdoor temperature is lower than the set point.

In that case, the compressors stop, reducing the cooling system consumption to the treatment ventilation.

### Dynamic defrost (under patent)

Heat pump units generally start defrosting when the outside temperature is below a given value. The cycle repeats periodically. This results sometimes in starting an expensive defrost cycle when it is very cold outside but very dry: in other words, when the coil is not frozen.

After many tests in the Lennox laboratory, it was found that it is possible to know exactly when the coil is frozen, by analysing the temperature difference between the coil and the outside temperature.

With this built-in feature of the CLIMATIC 60, Lennox ensures to start a defrost only when necessary, hence saving energy and improving comfort.



## Gained values at 0°C, 90% humidity:

### On energy efficiency:

The defrost cycles starts only when required: divided by 3 to 4 the number of cycles.

At the conditions mentioned, dynamic defrost saves up to 2h15 minutes of cooling cycles over 1day.

Those 2h15 minutes equals energy savings per day: 9% of energy saving.

### On comfort:

In defrost cycles the air conditioning units operations are reversed. It means that instead of supplying heat in winter, it supplies cold.

Speaking comfort, dynamic defrost avoids up to 2h15 minutes of cold air supply per day.

## R410a refrigerant & Scroll compressors

Combined with scroll compressors on the whole range, R410A technology offers the optimal cooling and heating efficiency.

## Timezone management

As a standard feature, CLIMATIC 60 provide time zone scheduling: respectively 2 and 4 scheduling time zones per day on 2 periods per week (week / weekend) or 7 days. This allows energy consumption management according to the building use.

On each of the time zones, heating set point, cooling set point, minimum fresh air, humidity set point high and up, and even the different authorisations for cooling and heating can be adjusted.

## Dynamic setpoint

Throughout the year, the cooling requirement is not the same. Also the comfort requirement in a building depends on the outdoor temperature. Entering in a 22°C room when outdoor temperature is 35°C can create a feeling of cold instead of comfort. The dynamic set point function adapts the temperature set point throughout the year, increasing in hot days, approaching initial set temperature in more "average" days. This also creates energy savings, helping the COMPACTAIR to reach the right temperature quicker

## COMFORT & AIR QUALITY

### Fresh air management

Fresh air is an important point for comfort. In many countries, local building regulations make fresh air mandatory in commercial premises in different ways.

The COMPACTAIR equipped with the "Economizer" enables a minimal permanent fresh air inlet.

### Air quality management

Fresh air is prior to supply the best ambient comfort. On the other hand, a fresh air input is an expensive operation at high and low temperature. Lennox supplies an intelligent management system allowing to adapt the fresh air level to the need of the building. The fresh air level can be adapted at the commissioning for permanent inlet. It can also be adapted to instant "Consumption" with an Air Quality sensor, in order to maximize efficiency and fresh air level.

## G4 filtration

Two filtration levels are available. The standard equipment is G4 washable and refillable filters with metallic frame 50 mm. Units have F7 filters + G4 filters as an option. This configuration allows extending the lifecycle of filters and reducing the cost of replacement, changing only the media. 50 mm filters have been selected also to reduce the energy consumption due to lower pressure drop especially when the filters start being dirty.

## Low operating noise

COMPACTAIR offers the best low noise performance of the vertical packaged HVAC market, considering supplied noise in diffusion duct, exhausted noise to the external environment & radiated noise around the unit are all performing at the highest of market standard. While designing the COMPACTAIR unit for indoor installation and urban areas, the noise power level was considered critical by Lennox. Therefore, Lennox offers the possibility to reduce the operating noise for most of the standard conditions, with the proportional regulation of the fan in low noise control option. This feature limits the noise at the minimal level on demand.

**OUTDOOR NOISE POWER LEVEL**

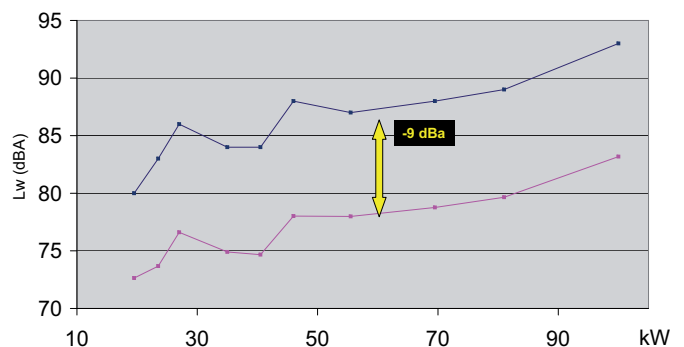

**RADIATED NOISE POWER LEVEL**

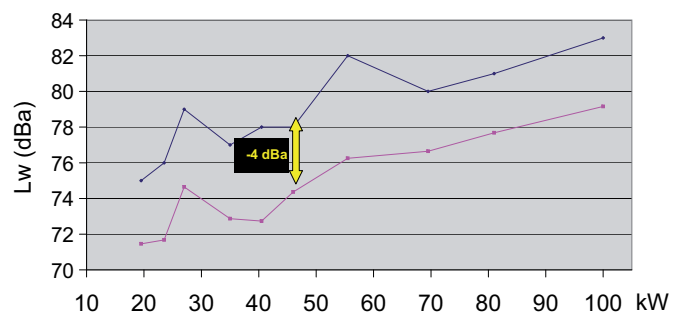

## CONTROL

COMPACTAIR is equipped with CLIMATIC 60 control platform which benefits from the better Lennox software experience and the improvements of previous versions . CLIMATIC 60 controller intelligently improves efficiency and helps set up and service operations to guarantee long lasting performance

### OPTIMIZED OPERATION AND SETUP SAVES ENERGY

CLIMATIC 60 is designed to provide the best energy efficiency throughout units life cycle while ensuring reliable and consistent operation with user friendly interfaces.

*This control has the following features :*

#### Refrigeration circuit efficiency management

The new PI algorithm of the CLIMATIC 60 controls the supply air temperature and a temperature difference between supply and return. It is able to optimize the refrigeration circuit operation to match perfectly the required cooling or heating load maximizing efficiency and comfort thanks to multiscroll compressor staging and thermostatic expansion valves.

It will also improve reliability with features such as compressor operating limits monitoring (high and low refrigerant pressure and temperature now measured and displayed on DS60 and Bus), or compressor operating time equalization and protection against excessive short cycling.

The COMPACTAIR units benefit from an extended operating envelop thanks to its large heat exchangers and the possibility to unload compressors when outdoor temperature is very high (above 48°C) This feature will ensure that some cooling is still provided even with temperatures above 48°C.

#### Dynamic defrost

It is a standard feature of all Lennox heat pumps. It limits the number and the duration of the defrost cycles in winter to maximize COP.

#### Free cooling

It is one of the most important features of this unit as it maximises seasonal efficiency by reducing the use of thermodynamic cooling in mid season.

#### Intelligent fresh air management:

With accurate percentage of fresh air the dampers are regularly calibrated to introduce just the required amount of fresh air in the building to reduce annual energy consumption. The fresh air ratio can also be controlled using the indoor CO2 level as an input.

#### Intelligent heating priority optimization:

This feature, unique on the market, allows the user to program the priority between the different heating elements, electrical heaters or hot water coils. This feature maximizes energy efficiency by optimizing heat pump operation depending on the outdoor temperature.

#### Step of heating priority

CLIMATIC 60 allows the user to decide which heating source will come first. This works perfectly on units using auxiliary heaters, it is possible to prioritize heat pump mode down to an adjustable set point (for example 0°C) and switch to hot water heating mode below this value. This gives the benefit of the excellent heat pump COP when outside temperature is not too cold and allows using hot water heated by gas boiler or solar panels when temperature is appropriate.

#### Flexibility

CLIMATIC 60 offers incredible flexibility. For example, advanced users can go in the heart of the regulation in deciding reactivity of the PI algorithm or by setting supply temperature limits .They might even decide to authorize or not some heating or cooling device depending of the outside temperature.

#### Automatic summer/winter time change

CLIMATIC 60 offers an automatic time switch from winter to summer. This had always been a problem in the past for some customers to have kept their unit at the right time, jeopardising all their effort to optimize energy consumption by smart scheduling.

#### Noise reduction feature

During unoccupied timezone, COMPACTAIR will work on half of its capacity by using only half of the compressors and half of the condensing fans (for double circuits units).

Therefore it may cycle more often but is quieter when running. This option is very often used at night when the capacity needed is lower and when low noise matters more.

#### Last 32 faults stored in the mother board

Part of the new features of CLIMATIC 60 is the storage in the main mother board of the last 32 faults with time, date and fault code. This can be seen with DS60 Service Display or ADALINK even if they were not connected when the fault occurred.

#### Staggered start feature

If there is a power shortage, units will not restart at the same time. To make this feature available, units have to be addressed with a different number between 1 and 12. The unit will start a number of minutes after power return depending on its address (Address \* 10 seconds). Example : unit number 3 will start 30 seconds after power is back. This is a very important feature to avoid peaks of current.

## Morning anticipation and dynamic set point

The unit can be programmed to switch-on in the morning to reach the occupied zone temperature set point just in time.

The unit will start heating the building at a different time in the morning depending on the outdoor temperature: The lower the outdoor temperature, the earlier the unit would start to ensure that the set point is reached by the time the first occupied zone (Z1) is starting. This is to avoid early start when outdoor temperature is mild.

Example for a unit programmed to anticipate morning switch-on if outdoor temperature is below 10°C at a rate of 10 minutes/°C.

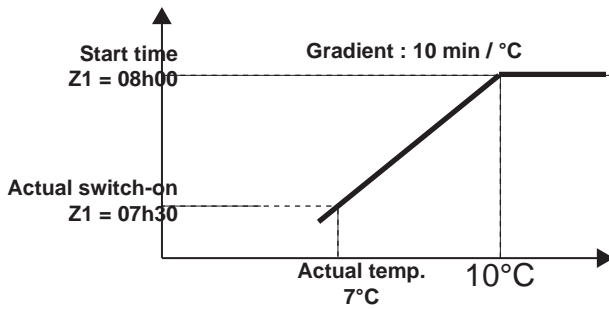

Dynamic set point can be used in summer to offset the ambient temperature set point according to the outdoor temperature. This is to avoid large temperature difference between indoor and outdoor. The indoor temperature set point would then increase with the outdoor temperature improving comfort and saving large amount of energy.

## Communication and unit interlink

Master/slave or cascade control is a standard feature of the COMPACTAIR units. It can be used to connect up to 24 units. The units can then be programmed to optimize efficiency and improve reliability following 6 different strategies:

### **1: Master Slave "total":**

The master gives the ventilation order, its set point and its room temperature/humidity/CO2 to all other units.

### **2: Master Slave "temperature":**

The master gives the ventilation order and the room temperature/humidity/CO2 to all other units, but each has its own set point.

### **3: Master Slave "average":**

The master gives the ventilation order and the room temperature/humidity/CO2 used by all units is the average of all units, each unit has its own set point.

### **4: Master Slave "cooling/heating":**

All units are stand-alone but the slaves have to have the same running mode as the master (cooling or heating).

### **5: Master Slave "back-up":**

One unit is the back-up and will operate if any of the other units is stopped due to a major problem.

### **6: Rolling back-up mode:**

Same as above, except the "back-up" unit will change once a week on Tuesday.

Note that, the outside temperature/humidity/CO2 given to all units can either be the average of all units connected or the external humidity/temperature of the master, allowing the use of a single "weather station" for the whole site.

## Faults and alarms

CLIMATIC 60 manages more than 90 different faults and alarms codes and can store the last 32 defaults with time and date. The stored faults and alarms can then be displayed on the DS60 and on the communication bus with the full text detail.

## Scheduling

In order to ensure the unit perfectly matches the requirements of the most difficult applications in terms of occupation and varying internal loads, the new CLIMATIC 60 offers now up to 7 time zones per day (Z0 to Z6) adjustable by steps of 10 minutes.

Each time zone can be programmed to follow one of four possible operating modes: A, B, C & D

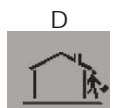
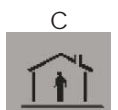
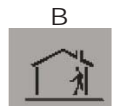
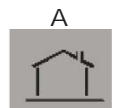



## EASE OF INSTALLATION & SERVICE

### Circuit breakers

To improve the safety of the COMPACTAIR and extend its life, circuit breakers protect against over-loading, over intensity and a disconnected supply phase. Maintenance is also improved as there is no requirement to change fuses. The electrical panel is manufactured in accordance with EN60204-1 (1998) electrical directive.

### Adjustable ventilation

The pulley and belt are adjusted in the factory to obtain the airflow rate and external static pressure the nearest to the site needs. However, once on site, the real characteristics of ventilation requirement might be slightly different than theory measured on drawings: therefore, COMPACTAIR is delivered as standard with adjustable pulley. This remains the possibility to adjust the airflow accurately at the commissioning and find the perfect airflow for the site comfort and system efficiency.

### Easy to access

All internal components access of the COMPACTAIR are closed by panels equipped by locks and handle for quick and easy dismounting. No more screws are used as panel fixtures.

### External access to pressure gauges

Pressure intakes are installed externally for easy pressure measurement. This common measure doesn't require access to the refrigeration section and the COMPACTAIR can continue to operate.

CLIMATIC 60 and eFlow™ can monitor the airflow rate and compensates for the dirty filters, while waiting for the necessary maintenance.

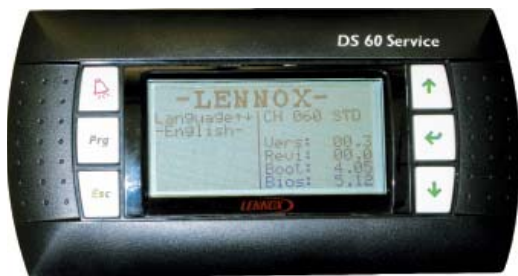

## EXTENDED LIFECYCLE

### Casing

Made of galvanized steel, the casing is covered with Epoxy RAL 9003 paint

### Assembly quality, compliance to PED 2014/68/EU, EN 60204-1, CE, made in an ISO 9001v2000 factory.

Electrical components are selected to the highest standards, refrigeration components are generously sized to ensure maximum performance and reliability. Quality manufacturing procedures together with a culture of continuous improvement at all LENNOX factories, ensure the products are built to the highest standards. COMPACTAIR complies to EN60204 norms, PED 2014/68/EU directive, is CE compliant and is built in an ISO9001v2000 certified factory.

## SAFETY

### Fire-insulation

Air treatment sections of COMPACTAIR are insulated with M1 material: this insures that the insulation doesn't burn and doesn't create toxic smoke.

As an option, we can fit M0 isolation on the thermodynamic unit.

## FRESH AIR OPTIONS

### Economizer module

"Free cooling" is provided through the use of fresh air when appropriate rather than cooling the return air. The use of an economiser is the easiest and most efficient way to modulate fresh air volumes and reduce running costs for commercial application, as well as improving air quality.

The fresh air management can be controlled in 2 accuracy ways:

- Minimal permanent fresh air percentage. The damper opening varies according to the volume of fresh air to be introduced to reach the minimum requested percentage.
- Automatic accurate adjustment of fresh air level according to instant room requirement. It adapts to fresh air consumption which varies with the number of visitors and their physical activity (available with fresh air quality sensor option only)

### **2 constructions are available :**

- on A & B-Box (models 020S to 045D), the module is made of 2 dampers- fresh air & return air - driven by an actuator. Both fresh air and return air are ducted. The module is delivered fixed to the supply part (can be delivered separately on demand).
- on C & D-Box (models 020S to 045D), the module is made of a 3 dampers –fresh air, return air & exhaust air- driven by 3 actuators. All dampers are ducted. The module is delivered loose from the Air treatment section.

**Sizes 20S to 45D**



**Sizes 55D to 100D**

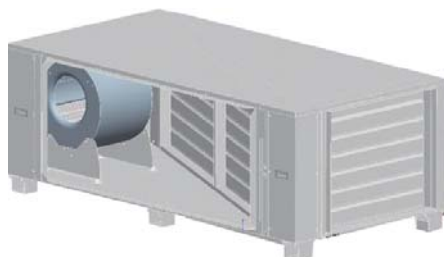

### Exhaust module

Combined with Economizer to eliminate the room overpressure when a large quantity of fresh air is introduced in the room. The fan starts only over a percentage of fresh air inlet.

Lennox provides 2 configurations depending the size of the air treatment section :

- On A Box and B Box (models 020S to 045D), the exhaust fan is supplied loose for installation in return duct or in any place on the building.
- On C Box and D Box (models 055D to 100D), the exhaust fan is integrated in the economizer: the overpressure is directly evacuated from the return.

### Return module

The return module is made for return duct circuit with high pressure drop. It offers up to 250-300Pa ESP.

The module is made of a extra box to connect with duct work to the Economizer. The return module is available on C and D Box (models 055D to 100D).

## INDOOR AIR QUALITY

### Air quality sensor

Quantity of fresh air is one the most important factor of People Comfort with T°C. The lack of fresh air in a room can lead the visitors to headaches or bad feeling due to increased carbon monoxide degree. This affects directly the commercial activity, especially in application where people stays an important time in the premises: restaurants, bars, theatres or shopping malls. The inlet of high fresh air volumes on a permanent way can also be very expensive. Lennox has developed specific functionality to reduce the inlet volume to the strict instant requirement, based on CO<sub>2</sub> level : this condition a permanent comfort and reduce the extra energy consumption of fresh air to a strict minimum.

### Advanced control for enthalpy and humidity

Where a higher level of controllability is required to make the COMPACTAIR even more flexible, LENNOX have compiled a pack that includes two advanced control features.

- "Enthalpy control on economiser". Software and its sensors will ensure that the economiser does not use 100% fresh air if the outside air has a higher enthalpy than the return air. This feature is relevant in regions where the relative humidity is high or when the desired room air condition is very dry.
- "Humidity control" software and its sensors, are able to analyze dry and wet bulb temperatures, and therefore can control a dehumidification algorithm. This will dehumidify the air in cooling mode as it passes through the coil, then reheating it with either electric heater or hot water coil. If there is a need to humidify the air, a proportional contact is available to control a humidifier that will be provided by the customer.

### Dirty filter sensor

This intelligent sensor informs the customer about the level of dirty in the filter , giving an alarm and indicating the status in the DS Service display .

### **G4/F7 filtration**

COMPACTAIR has an option filter F7 + pre-filter G4

- Filters in 50 mm G4 and 100 mm F7. This configuration allows extending the lifecycle of filters and reducing the cost of replacement, changing only the media.

## **AUXILIARY HEATERS**

Additional or instead of Heat Pumps, Lennox offers many auxiliary heaters on every Air-To-Air units. This helps to adapt to local climate requirement, local regulation preferences and applications variable heating needs.

### **Electrical heaters stepped or modulating**

Standard, medium and high heating power capacity are available on each unit size (capacity details table 4.3).

The standard, medium and high electrical heaters are two steps modulated, except standard capacities of 20 and 25 models which have only one step. Total modulating electrical heaters are available. They enable to reduce electrical peak consumption and to optimize comfort feeling.

The electric heater comprises of shielded resistance heaters, which are smooth anticorrosion tubes 8 W/cm<sup>2</sup> capacity. 3 security elements are insuring permanents control of the heaters:

- 2 High temperature limit control offers overload protection. An automatic reset safety thermostat is set at 75°C – a manual reset safety thermostat is set at 105 °C; both located at less 150 mm over electric heaters. This is provided as a standard feature on the electric heater, with the electric power supply cables made of reticulated silicon rubber, resistant to temperatures up to 200°C.
- an air pressure differential is control the fan activity and disconnect the electrical heater in case of critical airflow
- dual contactor are insuring safe redundancy in case of failure of one dry contact

### **Hot water coil**

Hot water coil is regulated by the CLIMATIC 60 proportionally. This modulating hot water coil is equipped with a 3 way valve offering accurate confort and precision . It is recommended to add glycol in case the hot water coil is going to be out of use during long periods of time , or in case of power supply absence .

## **REFRIGERATION OPTIONS**

### **Winter cooling operations down to 0°C**

This option allows the COMPACTAIR to work in cooling mode with an outside temperature down to 0°C (instead of 15°C in the standard unit). This is specifically needed when free-cooling operation is not possible. This function is made of condenser fan alternate start/stop that maintain a constant condensing pressure. Heat pump version has this possibility as standard

### **Service valves**

Consists in liquid and gas service valves that isolate the refrigerant section during maintenance. This is particularly useful when components of the circuit have to be changed. It reduces the time and cost of maintenance operation.

### **Refrigerant pre-charged**

The COMPACTAIR split are delivered with Nitrogen in the refrigerant circuit of the thermodynamic section. The compressor section can be fitted with refrigerant: in that case, the thermodynamic section would be equipped of service valves.

### **Long distance refrigerant connection**

In any situation where the distance between the thermodynamic section and the air treatment section is over 40 meters of copper piping, this kit has to be installed. It allows distance up to 65 meters.

## **INSTALLATION AND SAFETY**

### **Air socks control**

Slow starter of supply fan motor to introduce an increasing air volume over 1 minute in air socks. Help largely to protect the air socks ducts against braking.

Made by electronic slow start, Inverter technology.

This option is available as "Non Standard Request (NSR)"

### **Main disconnect switch**

Main disconnect switch is lockable to make a safe access to electrical panel. It is installed on the electrical panel door of the compressor section and controls all parts. Is also used as emergency cut off: it is mandatory to guarantee a proper access to this switch.

Main disconnect switch is sized accordingly to the options fitted in the unit.

### **Smoke detectors**

Located in the indoor unit, after the filter. Fotoelectric head of the smoke detector can detect any type of smoke. In this case it would initiate shutdown sequence the unit, fully close the return air damper and open the fresh air damper up to 100% and send an alarm signal to the unit. The safety protocol requires the presence of an economizer and exhaust capabilities.

In accordance with European norm and stronger regulation like French ERP regulation.

### **Compressor electrical protection**

Return lock against 3 phases inversion at installation. This protection prevents the Scroll compressor to start and operate in wrong sense: in the case that the electrical phases are wrong connected, the compressor will not start. Particularly required when the installation of the AC unit is made before the installation of electrical wirings.

### **Coil anticorrosion protection**

Lennox can provide several type of coil anticorrosion protection specifically made for salted or polluted environments.

For low polluted and salted environments, Lennox is offering Aluminium Coated Coil. This option can be selected on external coil only or external and treatment coil for high level of fresh air are required.

This standard anticorrosion is particularly recommended in urban environnements.

For more aggressive environnements, such a coastal environment, Lennox offers solutions on special demand for Thermoguard treatment solutions. With Thermoguard treatment, coil are guaranteed against corrosion during 3-years (provided regular maintenance is performed). **Special option**

### ***MO isolation in air treatment section***

As standard, air treatment units are isolated with M1 isolation material. To comply with certain legislations, we can ask as an option for M0 classification, which is non flammable and self extinguishible .

### **IMPORTANT:**

COMPACTAIR units are designed for only indoor installation, in case of outdoor installation , please provide a structure that covers completely the unit and protect the air treatment unit, the thermodynamic unit and the electrical board from any water infiltration.

## **CONTROL, COMMUNICATION & SUPERVISION**

### **Inverter low noise control & winter cooling operations down to -15°C**

Acts on 3 characteristics of the unit:

- reduces radiated noise power level around 4 dB(A)
- reduces condenser in duct noise power level up to -9 dB(A)
- able very low ambient cooling operations in full security

COMPACTAIR units being mostly installed inside buildings in urban environment, the noise created might be particularly annoying at certain moments: during the night for neighbourhood, for visitors in the day. Therefore, the COMPACTAIR operation mode can be selected at any time zone for Low Noise or Performance. The Low Noise mode might work with high performance results up to high external temperature.

This option also able cooling operation in very cold ambient T°C with good performance on condenser fan belt lifecycle extension and starting peak current reduction.

### **DC 60 : Comfort Display**

This is CLIMATIC 60 remote controller for non-technical customer. It has been wanted to aesthetically fit inside a room and be very easy to use. It can be installed at maximum 500 meters from the unit. This graphical display gives information such as running mode of the unit, status of the fan, set point, % of fresh air, outside air temperature.

Customer can change the scheduling of the different time zone, can modify temperature set point and % of fresh air for each zone. Customer can also override the scheduling in either changing the set point for 3 hours or in forcing the rooftop to unoccupied mode for 1 to 7 days. ON/OFF key is also available. DC60 Comfort display, shows faults number when unit is in the failure mode. Customer can reset fault thanks to a combination of keys. Time and day of the unit can be seen and modified easily through the DC60.

### **DS 60 : Service Display**

This service display controller directly plugs on the external wall of the unit equipped by CLIMATIC 60 control platform. This allows service personal to set up to 90 settings, read up to 125 variables, up to 45 faults and read the history of the last 16 faults. This controller has been designed to be very user friendly, with 6 different keys, a 4 lines display and this controller includes scrolling menus and true language (no codes). It will be in English or an other alternate language.

### **DM 60: Multi-unit display**

This CLIMATIC 60 display offers the same possibilities than DC60 Customer Display applied to 12 units.

### **Extension control board - BE60**

This board enables extra inlet and outlet to the CLIMATIC 60. Allow 4 analogical inputs, 4 digital inputs and 4 digital outputs. Depending to the optional equipment selected, this equipment might be already available in the unit.

### **Modbus Communication interface**

This is a modbus interface, which is needed for anyone who would like a BMS system to talk to the COMPACTAIR with "Modbus protocol". No other hardware is required to have modbus dialog.

### **LonTalk® interface**

This board is a LonTalk® interface, which is needed for anyone who would like a BMS system to talk to the COMPACTAIR with «Lon protocol » with FTT10. No other hardware than this board is required to have LonTalk® dialog. One board required per unit.

### **Bacnet® interface**

This board is a Bacnet® interface, which is needed for anyone who would like a BMS system to talk to the COMPACTAIR with "Bacnet protocol» RS485.

### **TCB (Thermostat Control Board)**

This board has been developped for any customer who wants to take over the control of the unit. With 6 logical inputs (Compressor stage 1 and stage 2, heating step 1 and 2, 4 way valves and fan), this board will replace the control algorithme. However CLIMATIC 60 controller will stay in charge of all safety algorithme, defrost operation or free cooling operation. All Input are volt free contact. This is the perfect board, to have COMPACTAIR managed by a zoning system, a universal thermostat or even a BMS system.

### **Adalink Distant Monitoring**

Adalink is the solution for Retail & Light Commercial HVAC installation monitoring. It can control up to 32 units on the same site. Real gateway to the unit, Adalink can be used locally, via LAN network or directly plugged. It can be used remotely via modem. Adalink can show the whole site map showing status of the different units, zoom on each unit and allow the user to graphically change set point, access alarm list, look at trend curves.

Options	Models			
	Packaged	Split	Cooling only	Heat pump
<b>Air treatment section</b>				
<b>Fresh air</b>				
Economizer module			x	
Exhaust module			x	
Return module	Sizes 55 -100		Sizes 55 -100	
Airflow configuration	Refer to airflow configuration page 50			
<b>Indoor air quality</b>				
Air quality sensor	x	x	x	x
High filtration level - G4 prefilter / F7 filtration	x			
Analog dirty filter and fan control	x	x	x	x
<b>Auxiliar heater</b>				
Electrical heater - standard capacity -1 step	x			
Electrical heater - medium capacity - 2 steps	x			
Electrical heater - high capacity - 2 steps	x			
Electrical heater - high capacity - modulating capacity	x	x	x	x
Hot water coil - modulating capacity	x	x	x	x
<b>Control</b>				
Smoke detector	x			
Air socks control	NSR <sup>(1)</sup>			
Ambient remote sensor	x			
Remote duct sensor	x			
<b>Thermodynamic unit</b>				
<b>Refrigeration option</b>				
Winter cooling operations down 0 °C	x	x	x	STD
Service valves	-	x	x	x
Refrigerant precharged	STD	x	x	x
Long distance refrigerant connection 65 m	-	x	x	x
<b>Electrical and safety</b>				
Main switch	x			
Compressor electrical protection	x			
<b>Control &amp; Communication</b>				
Advanced control for enthalpy and humidity	x	x	x	x
Modbus	x			
LONWork Echelon	x	x	x	x
BACNet	x	x	x	x
Customer display DC60	x	x	x	x
Service display DS60	x	x	x	x
Multi-unit display DM 60	x	x	x	x
Extension control board - BE 60	x	x	x	x
TCB: connection for voltage free contact control	x	x	x	x
<b>Other options</b>				
Inverter low noise control - Winter cooling operation down -15°C	x			
Vertical air discharge - Thermodynamic unit	-	x	x	x
Coil anticorrosion protection - Thermodynamic unit	x			
Coil anticorrosion protection - Thermodynamic and air treatment unit	x			

(1) NSR = Non Standard Request



Table 2.1

COMPACTAIR		20S	25S	30S	35S	40S
<b>Cooling mode - CMC/ CSC + CIC</b>						
Net cooling capacity <sup>(1)</sup>	kW	18,8	23,1	26,0	33,8	38,8
Net absorbed power <sup>(1)</sup>		7,3	9,3	11,0	13,7	15,9
Net EER <sup>(1)</sup>		2,58	2,48	2,36	2,47	2,44
<b>Heating mode - CMH / CSH + CIH</b>						
Net heating capacity <sup>(1)</sup>	kW	19,7	25,9	30,4	37,2	43,7
Net absorbed power <sup>(1)</sup>		6,6	8,6	10,7	12,4	14,0
Net COP <sup>(1)</sup>		2,58	2,48	2,36	2,47	2,44
<b>Electrical data</b>						
Supply	V/Ph/Hz	400/3/50				
<b>Refrigerant circuit</b>						
Number of compressors /Number of circuits	1/1					
Total refrigerant charge (cooling only)	kg	4,3	5,4	6,0	7,8	9,0
Total refrigerant charge (heat pump)		4,5	5,5	6,2	8,0	9,3
<b>Air treatment ventilation</b>						
Minimum airflow rate	m <sup>3</sup> /h	3150	4250	4650	6200	6950
Maximum airflow rate		4100	5500	6000	8050	9050
Maximum available static pressure	Pa	450	550	550	550	600
<b>Thermodynamic section</b>						
Nominal airflow rate	m <sup>3</sup> /h	7600	8500	10000	12000	11700
Maximum available static pressure	Pa	178	223	272	209	205
<b>Auxiliary heating</b>						
Electrical heater capacity S/M/H <sup>(3)</sup>	kW	10/15/20			15/20/27	
Hot water coil capacity <sup>(2)</sup>		31	38	40	56	61
<b>Acoustic data</b>						
Sound power level radiated by thermodynamic unit <sup>(1)</sup> Standard unit (Lw)	dB(A)	82	85	86	85	85
Sound power level radiated by thermodynamic unit <sup>(1)</sup> Low noise unit (Lw)		75	76	77	76	76
Radiated sound power level in room <sup>(1)</sup> Packaged standard unit (Lw)		77	79	80	79	81
Radiated sound power level in room <sup>(1)</sup> Low noise packaged unit (Lw)		76	76	77	77	78
Sound power level <sup>(1)</sup> Indoor unit (Lw)		75	82	82	82	85
<b>Operating limits</b>						
<b>Cooling mode</b>	Maximum indoor air temperature	32°C DB / 23°C WB				
	Minimum indoor air temperature	21°C DB / 15°C WB				
	Maximum outdoor air temperature	45	45	45	47	47
	Minimum outdoor air temperature	15°C - Standard - Cooling only 0°C - Standard - Heat pump units				
<b>Heating mode</b>	Maximum indoor air temperature	27°C DB				
	Minimum indoor air temperature	15°C DB				
	Maximum outdoor air temperature	27°C (Indoor temperature = 20°C)				
	Minimum outdoor air temperature	-12°C DB (Indoor temperature = 20°C)				

(1) EUROVENT conditions

Cooling mode :  
 Outdoor temperature = 35°C DB  
 Entering coil temperature 27°C DB/19°C WB

Heating mode :

Outdoor temperature = 7°C DB / 6°C WB  
 Indoor temperature = 20°C DB

(2) Air inlet temperature = 20°C  
 Water temperature = 90-70°C

(3) S = Standard capacity  
 M = Medium capacity  
 H = High capacity

(4) -15°C with optional low temperature kit

Table 2.2

COMPACTAIR		45D	55D	70D	85D	100D
<b>Cooling mode - CMC/ CSC + CIC</b>						
Net cooling capacity <sup>(1)</sup>	kW	43,5	54,0	66,2	78,0	96,8
Net absorbed power <sup>(1)</sup>		18,9	21,5	27,8	32,6	40,7
Net EER <sup>(1)</sup>		2,30	2,51	2,38	2,39	2,38
<b>Heating mode - CMH / CSH + CIH</b>						
Net heating capacity <sup>(1)</sup>	kW	52,0	61,0	72,8	86,0	105,1
Net absorbed power <sup>(1)</sup>		17,4	20,3	24,8	28,5	35,4
Net COP <sup>(1)</sup>		2,99	3,00	2,94	3,02	2,97
<b>Electrical data</b>						
Supply	V/Ph/Hz	400/3/50				
<b>Refrigerant circuit</b>						
Number of compressors /Number of circuits		2/2	2/2	2/2	2/2	3/2
Total refrigerant charge (cooling only)	kg	10,3	12,5	15,5	18,5	23,0
Total refrigerant charge (heat pump)		10,6	12,6	16,0	19,1	25,2
<b>Air treatment ventilation</b>						
Minimum airflow rate	m <sup>3</sup> /h	7950	9950	12450	14000	17350
Maximum airflow rate		9750	12850	15090	16725	22450
Maximum available static pressure	Pa	550	650	650	600	600
<b>Thermodynamic section</b>						
Nominal airflow rate	m <sup>3</sup> /h	14000	20000	21000	22000	15500+ 11700
Maximum available static pressure	Pa	237	299	272	277	239+ 201
<b>Auxiliary heating</b>						
Electrical heater capacity S/M/H <sup>(3)</sup>	kW	15/20/27	20/27/40			27/40/ 50
Hot water coil capacity <sup>(2)</sup>		66	91	105	113	171
<b>Acoustic data</b>						
Sound power level radiated by thermodynamic unit <sup>(1)</sup> Standard unit (Lw)	dB(A)	88	87	88	89	92
Sound power level radiated by thermodynamic unit <sup>(1)</sup> Low noise unit (Lw)		78	78	79	80	83
Radiated sound power level in room <sup>(1)</sup> Packaged standard unit (Lw)		82	82	82	83	-
Radiated sound power level in room <sup>(1)</sup> Low noise packaged unit (Lw)		80	78	80	81	-
Sound power level <sup>(1)</sup> Indoor unit (Lw)		86	80	85	87	85
<b>Operating limits</b>						
<b>Cooling mode</b>	Maximum indoor air temperature	32°C BS / 23°C BH				
	Minimum indoor air temperature	21°C BS / 15°C BH				
	Maximum outdoor air temperature	45	45	47	47	47
	Minimum outdoor air temperature	15°C - Standard - Cooling only 0°C - Standard - Heat pump units				
<b>Heating mode</b>	Maximum indoor air temperature	27°C DB				
	Minimum indoor air temperature	15°C DB				
	Maximum outdoor air temperature	27°C (Indoor temperature = 20°C)				
	Minimum outdoor air temperature	-12°C DB (Indoor temperature = 20°C)				

(1) EUROVENT conditions  
Cooling mode :  
Outdoor temperature = 35°C DB  
Entering coil temperature 27°C DB/19°C WB

Heating mode :  
Outdoor temperature = 7°C DB / 6°C BH  
Indoor temperature = 20°C DB

(2) Air inlet temperature = 20°C  
Water temperature = 90-70°C

(3) S = Standard capacity  
M = Medium capacity  
H = High capacity

(4) -15°C with optional low temperature kit

### CALCULATION OF CAPACITY DEPENDING ON AIR FLOW

Data based on the following nominal indoor fan air flow

MODELS	020S	025S	030S	035S	040D	045D	055D	070D	085D	100D
Indoor airflow rate (m <sup>3</sup> /h)	8700	5000	5450	7100	8150	9400	11700	14650	16250	20400

### CORRECTION COEFICIENT TO FIX THE CAPACITY OF DIFFERENT INDOOR AIR FLOW

	% Nominal airflow rate				
	70%	80%	90%	100%	110%
Total capacity	0.96	0.97	0.98	1	1.01
Sensible capacity	0.90	0.93	0.96	1	1.03
Power input	0.98	0.99	1	1	1.01

Data based on the following nominal outdoor fan air flow

MODELS	020S	025S	030S	035S	040D	045D	055D	070D	085D	100D
Indoor airflow rate (m <sup>3</sup> /h)	7600	8500	10000	12000	11700	14000	20000	21000	22000	15500+ 11700

### CORRECTION COEFICIENT TO FIX THE CAPACITY OF DIFFERENT OUTDOOR AIR FLOW

	% Nominal airflow rate				
	70%	80%	90%	100%	110%
Total capacity	0.98	0.99	0.99	1	1
Sensible capacity	0.98	0.99	0.99	1	1
Power input	1.02	1.01	1.01	1	0.99

STEP 1 : INPUT	STEP 1 : EXAMPLE
Calculate the total and sensible loads of the area to be conditioned at design conditions.	
<b>A.</b> Total cooling load in kW	<b>A.</b> 32 kW
<b>B.</b> Summer design condition – Winter design conditions	<b>B.</b> Summer :35°C outdoor temperature, 24°C DB, 19°C WB entering air condition (room return air) Winter : -5°C outdoor temperature, 20°C DB entering air condition ( room return air)
<b>C.</b> Air flow needed percentage of fresh air and external static pressure (to overcome system losses, eg ductwork, diffusers.)	<b>C.</b> 6 200 m³/h at 200 Pa
<b>D.</b> Accessories needed	<b>D.</b> Economiser and 20 kW electric heater
STEP 2 : COOLING CAPACITY	STEP 2
<b>A.</b> Preselect the equipment using 'general data' in tables 2.1-2.2 to find units close to the required capacity.	<b>A.</b> Table 2.1 shows that CMH 035 will give 33,8 kW net at nominal operating conditions.
<b>B.</b> Size the equipment using the 'cooling performance' in tables 4.1-4.10 to match the cooling loads at design conditions.	<b>B.</b> Table 4.4a shows that a CMH 035 has a gross cooling capacity of 35,8 kW.
<b>C.</b> To establish the net capacity, the supply and condenser fan motor power should be subtracted. Review the supply fan performance in tables 3.1-3.10 with the required air flow and static pressure (do not forget to add the pressure drop for accessories in table 3.15) Review the condenser fan performance in tables 3.1-3.10 with the static pressure required.	<b>C.</b> Table 3.15 shows that economiser and 20 kW electric heater will add 51 Pa to the external static specified, giving a total of 251 Pa. The table 3.4 shows that high pressure fan (0,8 kW) is required for a CMH 035. providing 6 200 m³/h at 250 Pa. The net capacity is therefore 35,8 kW - 0,8 kW = 35,0 kW
STEP 3 : HEATING CAPACITY	STEP 3
<b>A.</b> Heat pump (*) The selection procedure is the same as that undertaken for cooling. Preselect equipment in "General data" in tables 2.1-2.2 Obtain the net heating capacity at design condition (winter conditions) from tables 4.1-4.13. Obtain the net capacity by adding the supply fan power (selected above) to the gross capacity.	<b>A.</b> Table 4.4b shows that CMH 035 will give 26,93 kW gross at design conditions.
<b>B.</b> Other Heating Select hot water coil in tables 4.11, electric heater in table 4.12.	<b>B.</b> The table 4.4b shows that high pressure fan (0,8 kW) is required for a CMH 035 providing 6 200 m³/h at 250 Pa.  The net capacity is therefore 26,3 kW + 0,8 kW = 27,73 kW The table 4.4 shows that a 20 kW electrical heater is required. The net capacity is therefore : 26,3 kW + 0,8 kW + 20 kW = 47,73 kW
(*) : This procedure doesn't take into account the impact of defrost in the heating performance. Depending on the outdoor moisture and temperature condition, the defrost operation might reduce the heat pump capacity.	
STEP 4 : ELECTRICAL DATA	STEP 4
Data from table 7.1-7.4	
<b>A.</b> Heat pump unit $P_a = P(\text{Unit} + \Delta \text{supply fan kit} + \text{Exhaust module} + \text{Electric heater} + \Delta \text{PLn})$ $I_a = I_a(\text{Unit} + \Delta \text{supply fan kit} + \text{Exhaust module} + \text{Electric heater} + \Delta \text{ILn})$ $I_d/I_a(\text{base}) = \text{Table 7.1} - 7.3$ $I_d = I_a(\text{base}) \times I_d/I_a(\text{base}) + I_a(\Delta \text{supply fan kit} + \text{Exhaust module} + \text{Electric heater})$	<b>A.</b> Table 7.1 -7.4 shows that for a CMH 035 With 20 kW Electric heater + High pressure fan $I_{a1} = 35,2 + 1,35 = 36,55 \text{ A}$ $P_1 = 20,9 + 0,8 = 21,7 \text{ kW}$
<b>B.</b> Cooling unit $P_1, I_{a1} (\text{summer operation}) = P, I_a(\text{Unit} + \Delta \text{fan kit supply} + \text{Exhaust module})$ $P_2 (\text{winter operation}) = P(\Delta \text{supply fan kit} + \text{Exhaust module} + \text{Electric heater})$ $I_{a2} (\text{winter operation}) = I_a(\Delta \text{supply fan kit} + \text{Exhaust module} + \text{Electric heater})$  $P_a = \max (P_1; P_2)$ $I_a = \max (I_{a1}; I_{a2})$  $I_d/I_a(\text{base}) = \text{Table 7.1-7.4}$ $I_d = I_a(\text{base}) \times I_d/I_a(\text{base}) + I_a(\Delta \text{kit indoor optional} + \text{Exhaust module} + \text{Electric heater} + \text{gas})$	$I_{a2} = 35,2 + 1,35 + 28,6 = 65,15 \text{ A}$ $P_2 = 20,9 + 0,8 + 20 = 41,7 \text{ kW}$  $P_2 > P_1$ so $P = P_2 = 41,7 \text{ kW}$ $I_{a2} > I_{a1}$ so $I_a = I_{a2} = 65,15 \text{ A}$  $I_d$ value is given in table nr 7.6 $I_d = 144 + 1,35 + 28,6 = 173,95 \text{ A}$

**TREATMENT VENTILATION DATA**

Table 3.1

Size 20S	ASP	100 Pa			150 Pa			200 Pa			250 Pa		
	Airflow (m³/h)	Kit	PI	rpm	Kit	PI	rpm	Kit	PI	rpm	Kit	PI	rpm
	3150	STD	1x0,55	682	STD	1x0,55	788	HP1	1x1,1	890	HP1	1x1,1	980
3425	STD	1x0,55	699	STD	1x0,55	800	HP1	1x1,1	896	HP1	1x1,1	984	
3700	STD	1x0,55	717	STD	1x0,55	813	HP1	1x1,1	909	HP1	1x1,1	991	
4100	STD	1x0,55	735	No kit			HP1	1x1,1	921	HP1	1x1,1	1003	
Size 20S	ASP	300 Pa			350 Pa			400 Pa			450 Pa		
	Airflow (m³/h)	Kit	PI	rpm	Kit	PI	rpm	Kit	PI	rpm	Kit	PI	rpm
	3150	HP1	1x1,1	1060	HP2	1x1,1	1133	HP3	1x1,5	1204	HP3	1x1,5	1275
3425	HP1	1x1,1	1068	HP2	1x1,1	1135	HP3	1x1,5	1214	HP3	1x1,5	1281	
3700	HP1	1x1,1	1074	HP2	1x1,1	1138	HP3	1x1,5	1220	HP3	1x1,5	1289	
4100	HP1	1x1,1	1083	HP2	1x1,1	1141	HP3	1x1,5	1233	HP3	1x1,5	1293	

Table 3.2

Size 25S	ASP	100 Pa			150 Pa			200 Pa			250 Pa			300 Pa		
	Airflow (m³/h)	Kit	PI	rpm	Kit	PI	rpm	Kit	PI	rpm	Kit	PI	rpm	Kit	P	rpm
	4250	STD	1x1,1	753	STD	1x1,1	840	HP1	1x1,5	915	HP1	1x1,5	1009	HP1	1x1,5	1085
4625	STD	1x1,1	770	HP1	1x1,5	860	HP1	1x1,5	942	HP1	1x1,5	1021	HP1	1x1,5	1098	
5000	STD	1x1,1	806	HP1	1x1,5	883	HP1	1x1,5	956	HP1	1x1,5	1035	HP2	1x1,5	1091	
5500	STD	1x1,1	840	HP1	1x1,5	903	HP1	1x1,5	988	HP1	1x1,5	1059	HP2	1x1,5	1098	
Size 25S	ASP	350 Pa			400 Pa			450 Pa			500 Pa			550 Pa		
	Airflow (m³/h)	Kit	PI	rpm	Kit	PI	rpm	Kit	PI	rpm	Kit	PI	rpm	Kit	P	rpm
	4250	HP2	1x1,5	1160	HP2	1x1,5	1233	HP2	1x1,5	1279	HP3	1x2,2	1358	HP3	1x2,2	1420
4625	HP2	1x1,5	1169	HP2	1x1,5	1238	HP2	1x1,5	1281	HP3	1x2,2	1364	HP3	1x2,2	1426	
5000	HP2	1x1,5	1176	HP2	1x1,5	1246	HP3	1x2,2	1310	HP3	1x2,2	1371	HP3	1x2,2	1431	
5500	HP3	1x2,2	1195	HP3	1x2,2	1258	HP3	1x2,2	1321	HP3	1x2,2	1380	HP3	1x2,2	1441	

Table 3.3

Size 30S	ASP	100 Pa			150 Pa			200 Pa			250 Pa			300 Pa		
	Airflow (m³/h)	Kit	PI	rpm	Kit	PI	rpm	Kit	PI	rpm	Kit	PI	rpm	Kit	P	rpm
	4650	STD	1x1,1	797	STD	1x1,1	876	HP1	1x1,5	956	HP1	1x1,5	1038	HP2	1x2,2	1113
5050	STD	1x1,1	822	STD	1x1,1	903	HP1	1x1,5	980	HP1	1x1,5	1051	HP2	1x2,2	1126	
5450	STD	1x1,1	856	HP1	1x1,5	932	HP1	1x1,5	1003	HP1	1x1,5	1074	HP2	1x2,2	1141	
6000	STD	1x1,1	895	HP1	1x1,5	970	HP1	1x1,5	1034	HP1	1x1,5	1098	HP2	1x2,2	1161	
Size 30S	ASP	350 Pa			400 Pa			450 Pa			500 Pa			550 Pa		
	Airflow (m³/h)	Kit	PI	rpm	Kit	PI	rpm	Kit	PI	rpm	Kit	PI	rpm	Kit	P	rpm
	4650	HP2	1x2,2	1184	HP2	1x2,2	1251	HP2	1x2,2	1295	HP3	1x3	1380	HP3	1x3	1438
5050	HP2	1x2,2	1197	HP2	1x2,2	1261	HP2	1x2,2	1298	HP3	1x3	1386	HP3	1x3	1445	
5450	HP2	1x2,2	1208	HP2	1x2,2	1271	HP2	1x2,2	1303	HP3	1x3	1395	HP3	1x3	1453	
6000	HP2	1x2,2	1227	HP2	1x2,2	1278	HP3	1x3	1349	HP3	1x3	1407	HP3	1x3	1465	

Table 3.4

Size 35S	ASP	100 Pa			150 Pa			200 Pa			250 Pa			300 Pa		
	Airflow (m³/h)	Kit	PI	rpm	Kit	PI	rpm	Kit	PI	rpm	Kit	PI	rpm	Kit	P	rpm
	6200	STD	1x1,5	640	STD	1x1,5	720	HP1	1x2,2	788	HP1	1x2,2	849	HP1	1x2,2	912
6650	STD	1x1,5	663	STD	1x1,5	735	HP1	1x2,2	797	HP1	1x2,2	863	HP1	1x2,2	922	
7100	STD	1x1,5	688	HP1	1x2,2	749	HP1	1x2,2	813	HP1	1x2,2	873	HP1	1x2,2	931	
8050	STD	1x1,5	735	HP1	1x2,2	788	HP1	1x2,2	848	HP1	1x2,2	903	HP2	1x3	956	
Size 35S	ASP	350 Pa			400 Pa			450 Pa			500 Pa			550 Pa		
	Airflow (m³/h)	Kit	PI	rpm	Kit	PI	rpm	Kit	PI	rpm	Kit	PI	rpm	Kit	P	rpm
	6200	HP2	1x3	972	HP2	1x3	1028	HP2	1x3	1066	HP3	1x3	1134	HP3	1x3	1183
6650	HP2	1x3	979	HP2	1x3	1035	HP2	1x3	1068	HP3	1x3	1139	HP3	1x3	1188	
7100	HP2	1x3	986	HP2	1x3	1044	HP2	1x3	1071	HP3	1x3	1144	No kit			
8050	HP2	1x3	1010	HP2	1x3	1052	HP3	1x3	1111	HP3	1x3	1159	No kit			

**ASP (Pa)** Available static pressure

**PI (kW)**

Power input



**TREATMENT VENTILATION DATA**

Table 3.5

Size 40D	ASP	100 Pa			150 Pa			200 Pa			250 Pa			300 Pa			350 Pa		
	Airflow (m³/h)	Kit	PI	rpm	Kit	PI	rpm	Kit	PI	rpm	Kit	PI	rpm	Kit	PI	rpm	Kit	PI	rpm
	6950	STD	1x2,2	690	STD	1x2,2	757	STD	1x2,2	821	HP1	1x2,2	882	HP2	1x3	940	HP2	1x3	997
7550	STD	1x2,2	726	STD	1x2,2	782	HP1	1x2,2	838	HP1	1x2,2	900	HP2	1x3	956	HP2	1x3	1010	
8150	STD	1x2,2	748	STD	1x2,2	808	HP1	1x2,2	863	HP1	1x2,2	919	HP2	1x3	973	HP2	1x3	1024	
9050	STD	1x2,2	799	HP1	1x2,2	851	HP1	1x2,2	902	HP2	1x3	951	HP2	1x3	1002	HP2	1x3	1069	
Size 40D	ASP	400 Pa			450 Pa			500 Pa			550 Pa			600 Pa					
	Airflow (m³/h)	Kit	PI	rpm	Kit	PI	rpm	Kit	PI	rpm	Kit	PI	rpm	Kit	PI	rpm			
	6950	HP2	1x3	1048	HP2	1x3	1103	HP3	1x4	1154	HP3	1x4	1202	HP3	1x4	1250			
	7550	HP2	1x3	1053	HP3	1x4	1117	HP3	1x4	1162	HP3	1x4	1209	No kit					
	8150	HP2	1x3	1059	HP3	1x4	1125	HP3	1x4	1172	HP3	1x4	1216	No kit					
9050	HP2	1x3	1069	HP3	1x4	1144	HP3	1x4	1189	HP3	1x4	1233	No kit						

Table 3.6

Size 45D	ASP	100 Pa			150 Pa			200 Pa			250 Pa			300 Pa		
	Airflow (m³/h)	Kit	PI	rpm	Kit	PI	rpm	Kit	PI	rpm	Kit	PI	rpm	Kit	PI	rpm
	7950	STD	1x2,2	738	STD	1x2,2	800	HP1	1x3	857	HP1	1x3	912	HP1	1x3	967
8675	STD	1x2,2	779	STD	1x2,2	833	HP1	1x3	886	HP1	1x3	938	HP1	1x3	986	
9400	STD	1x2,2	817	STD	1x2,2	867	HP1	1x3	917	HP1	1x3	966	HP1	1x3	1014	
9750	STD	1x2,2	838	HP1	1x3	884	HP1	1x3	931	HP1	1x3	979	HP1	1x3	1027	
Size 45D	ASP	350 Pa			400 Pa			450 Pa			500 Pa			550 Pa		
	Airflow (m³/h)	Kit	PI	rpm	Kit	PI	rpm	Kit	PI	rpm	Kit	PI	rpm	Kit	PI	rpm
	7950	HP1	1x3	1019	HP2	1x4	1058	HP3	1x4	1154	HP3	1x4	1168	HP3	1x4	1216
	8675	HP1	1x3	1041	HP2	1x4	1064	HP3	1x4	1136	HP3	1x4	1183	HP3	1x4	1226
	9400	HP2	1x4	1052	HP2	1x4	1073	HP3	1x4	1150	HP3	1x4	1196	HP3	1x4	1240
9750	HP2	1x4	1056	HP3	1x4	1117	HP3	1x4	1161	HP3	1x4	1204	HP3	1x4	1250	

Table 3.7

Size 55D	ASP	100 Pa			150 Pa			200 Pa			250 Pa			300 Pa			350 Pa		
	Airflow (m³/h)	Kit	PI	rpm	Kit	PI	rpm	Kit	PI	rpm	Kit	PI	rpm	Kit	PI	rpm	Kit	PI	rpm
	9950	STD	1x2,2	666	STD	1x2,2	748	STD	1x2,2	828	HP1	1x3	903	HP1	1x3	967	HP1	1x3	1033
10825	STD	1x2,2	688	STD	1x2,2	770	HP1	1x3	842	HP1	1x3	913	HP1	1x3	986	HP1	1x3	1041	
11700	STD	1x2,2	704	STD	1x2,2	786	HP1	1x3	859	HP1	1x3	931	HP1	1x3	992	HP2	1x4	1010	
12850	STD	1x2,2	741	HP1	1x3	820	HP1	1x3	881	HP1	1x3	946	HP2	1x4	971	HP2	1x4	1027	
Size 55D	ASP	400 Pa			450 Pa			500 Pa			550 Pa			600 Pa			650 Pa		
	Airflow (m³/h)	Kit	PI	rpm	Kit	PI	rpm	Kit	PI	rpm	Kit	PI	rpm	Kit	PI	rpm	Kit	PI	rpm
	9950	HP2	1x4	1047	HP2	1x4	1103	HP2	1x4	1138	HP3	1x5,5	1207	HP3	1x5,5	1256	HP3	1x5,5	1303
	10825	HP2	1x4	1057	HP2	1x4	1109	HP2	1x4	1140	HP3	1x5,5	1214	HP3	1x5,5	1262	HP3	1x5,5	1309
	11700	HP2	1x4	1065	HP2	1x4	1115	HP2	1x4	1172	HP3	1x5,5	1220	HP3	1x5,5	1268	No kit		
12850	HP2	1x4	1078	HP3	1x5,5	1132	HP3	1x5,5	1182	HP3	1x5,5	1232	No kit			No kit			

Table 3.8

Size 70D	ASP	100 Pa			150 Pa			200 Pa			250 Pa			300 Pa			350 Pa		
	Airflow (m³/h)	Kit	PI	rpm	Kit	PI	rpm	Kit	PI	rpm	Kit	PI	rpm	Kit	PI	rpm	Kit	PI	rpm
	12450	STD	1x3	738	STD	1x3	819	STD	1x3	888	HP1	1x4	959	HP1	1x4	1014	HP2	1x5,5	1033
13550	STD	1x3	776	STD	1x3	845	HP1	1x4	909	HP1	1x4	972	HP1	1x4	1033	HP2	1x5,5	1047	
14650	STD	1x3	807	HP1	1x4	871	HP1	1x4	931	HP1	1x4	993	HP2	1x5,5	1016	HP2	1x5,5	1069	
15090	STD	1x3	819	HP1	1x4	882	HP1	1x4	943	HP1	1x4	1002	HP2	1x5,5	1027	HP2	1x5,5	1078	
Size 70D	ASP	400 Pa			450 Pa			500 Pa			550 Pa			600 Pa			650 Pa		
	Airflow (m³/h)	Kit	PI	rpm	Kit	PI	rpm	Kit	PI	rpm	Kit	PI	rpm	Kit	PI	rpm	Kit	PI	rpm
	12450	HP2	1x5,5	1087	HP2	1x5,5	1125	HP3	1x7,5	1189	HP3	1x7,5	1237	HP3	1x7,5	1275	HP3	1x7,5	1329
	13550	HP2	1x5,5	1101	HP2	1x5,5	1130	HP3	1x7,5	1197	HP3	1x7,5	1245	HP3	1x7,5	1292	HP3	1x7,5	1339
	14650	HP2	1x5,5	1113	HP2	1x5,5	1137	HP3	1x7,5	1212	HP3	1x7,5	1258	HP3	1x7,5	1303	No kit		
15090	HP2	1x5,5	1117	HP2	1x5,5	1140	HP3	1x7,5	1218	HP3	1x7,5	1264	HP3	1x7,5	1307	No kit			

**ASP (Pa)** Available static pressure      **PI (kW)** Power input

**TREATMENT VENTILATION DATA**

Table 3.9

Size 85D	ASP	100 Pa			150 Pa			200 Pa			250 Pa			300 Pa			350 Pa		
	Airflow (m³/h)	Kit	PI	rpm	Kit	PI	rpm	Kit	PI	rpm	Kit	PI	rpm	Kit	PI	rpm	Kit	PI	rpm
	14000	STD	1x4	805	STD	1x4	872	STD	1x4	937	HP1	1x5,5	995	HP2	1x7,5	1016	HP2	1x7,5	1070
	15125	STD	1x4	838	STD	1x4	898	HP1	1x5,5	959	HP1	1x5,5	1014	HP2	1x7,5	1040	HP2	1x7,5	1088
	16250	STD	1x4	863	STD	1x4	925	HP1	1x5,5	986	HP1	1x5,5	1041	HP2	1x7,5	1064	HP2	1x7,5	1109
	16725	STD	1x4	882	STD	1x4	937	HP1	1x5,5	994	HP2	1x7,5	1029	HP2	1x7,5	1073	HP2	1x7,5	1114

Size 85D	ASP	400 Pa			450 Pa			500 Pa			550 Pa			600 Pa		
	Airflow (m³/h)	Kit	PI	rpm	Kit	PI	rpm	Kit	PI	rpm	Kit	PI	rpm	Kit	PI	rpm
	14000	HP2	1x7,5	1114	HP2	1x7,5	1172	HP3	1x7,5	1214	HP3	1x7,5	1262	HP3	1x7,5	1303
	15125	HP2	1x7,5	1122	HP3	1x7,5	1184	HP3	1x7,5	1232	HP3	1x7,5	1275	HP3	1x7,5	1310
	16250	HP2	1x7,5	1130	HP3	1x7,5	1201	HP3	1x7,5	1245	HP3	1x7,5	1289	HP3	1x7,5	1331
	16725	HP2	1x7,5	1134	HP3	1x7,5	1209	HP3	1x7,5	1253	HP3	1x7,5	1295	HP3	1x7,5	1339

Table 3.10

Size 100D	ASP	100 Pa			150 Pa			200 Pa			250 Pa			300 Pa			350 Pa		
	Airflow (m³/h)	Kit	PI	rpm	Kit	PI	rpm	Kit	PI	rpm	Kit	PI	rpm	Kit	PI	rpm	Kit	PI	rpm
	17350	STD	1x4	591	STD	1x4	650	STD	1x4	710	HP1	1x5,5	763	HP1	1x5,5	815	HP2	2x4	825
	18875	STD	1x4	611	STD	1x4	670	STD	1x4	730	HP1	1x5,5	777	HP1	1x5,5	827	HP2	2x4	834
	20400	STD	1x4	637	STD	1x4	690	HP1	1x5,5	744	HP1	1x5,5	792	HP2	2x4	802	HP2	2x4	846
	22450	STD	1x4	670	HP1	1x5,5	721	HP1	1x5,5	770	HP2	2x4	788	HP2	2x4	822	HP2	2x4	863

Size 100D	ASP	400 Pa			450 Pa			500 Pa			550 Pa			600 Pa		
	Airflow (m³/h)	Kit	PI	rpm	Kit	PI	rpm	Kit	PI	rpm	Kit	PI	rpm	Kit	PI	rpm
	17350	HP2	2x4	870	HP2	2x4	903	HP3	2x4	959	HP3	2x4	997	HP3	2x4	1036
	18875	HP2	2x4	879	HP2	2x4	906	HP3	2x4	964	HP3	2x4	1003	HP3	2x4	1041
	20400	HP2	2x4	888	HP2	2x4	910	HP3	2x4	971	HP3	2x4	1009	No kit		
	22450	HP2	2x4	896	HP3	2x4	945	HP3	2x4	986	No kit			No kit		

**RETURN VENTILATION DATA**

Table 3.11

55 D Return fan		Airflow (m³/h)							
		9950		10825		11700		12850	
Airflow (rpm)		ASP	PI	ASP	PI	ASP	PI	ASP	PI
Closed pulley		755	255 2,37	257 2,56	260 2,77	260 2,77	260 3,05		
Pulley position	1 turn	715	230 2,11	232 2,30	234 2,48	233 2,75			
	2 turns	675	207 1,88	208 2,05	210 2,23	207 2,48			
	3 turns	635	184 1,67	184 1,82	184 1,99	180 2,22			
	4 turns	595	162 1,47	162 1,61	160 1,77	155 1,98			

Table 3.12

70 D Return fan		Airflow (m³/h)							
		12450		13550		14650		15090	
(rpm)		ASP	PI	ASP	PI	ASP	PI	ASP	PI
Closed pulley		755	260 2,93	260 3,22	258 3,52	255 3,65			
Pulley position	1 turn	715	235 2,64	233 2,91	228 3,20	225 3,32			
	2 turns	675	208 2,37	205 2,62	198 2,90	195 3,00			
	3 turns	635	182 2,12	176 2,36	168 2,61	165 2,72			
	4 turns	595	157 1,89	150 2,11	140 2,35	135 2,44			

Table 3.13

85 D Return fan		Airflow (m³/h)							
		14000		15125		16250		16725	
Airflow (rpm)		ASP	PI	ASP	PI	ASP	PI	ASP	PI
Closed pulley		755	260 3,44	255 3,77	250 4,13				
Pulley position	1 turn	715	230 3,12	225 3,43	215 3,75	212 3,90			
	2 turns	675	202 2,82	195 3,11	183 3,41	178 3,55			
	3 turns	635	173 2,53	165 2,80	153 3,09	145 3,22			
	4 turns	595	145 2,27	135 2,52	120 2,79	115 2,91			

Table 3.14

100 D Return fan		Airflow (m³/h)							
		17350		18875		20400		22450	
(rpm)		ASP	PI	ASP	PI	ASP	PI	ASP	PI
Closed pulley		672	293 3,81	293 4,25	291 4,60				
Pulley position	1 turn	636	263 3,46	261 2,88	258 4,22	251 4,77			
	2 turns	601	234 3,15	232 3,49	227 3,86	218 4,38			
	3 turns	565	205 2,83	202 3,15	196 3,48	185 3,98			
	4 turns	529	178 2,52	173 2,81	166 3,13	153 3,58			

**ASP (Pa)** Available static pressure

**PI (kW)** Power input

### OPTION PRESSURE DROP TABLE

Table 3.15

Unit Size	020S				025S				030S				035S			
<b>Airflow (m³/h)</b>	<b>3150</b>	<b>3425</b>	<b>3700</b>	<b>4100</b>	<b>4250</b>	<b>4625</b>	<b>5000</b>	<b>5500</b>	<b>4650</b>	<b>5050</b>	<b>5450</b>	<b>6000</b>	<b>6200</b>	<b>6650</b>	<b>7100</b>	<b>8050</b>
Options																
Economizer (Pa)	13	17	20	25	24	31	37	45	28	37	43	54	26	30	34	43
G4/F7 filtration (Pa)	85	93	102	115	120	133	146	165	133	148	163	184	128	140	152	178
Hot water coil (Pa)	15	17	20	23	25	28	32	38	29	33	37	44	25	29	32	39

Unit Size	040S				045D				055D			
<b>Airflow (m³/h)</b>	<b>6950</b>	<b>7550</b>	<b>8150</b>	<b>9050</b>	<b>7950</b>	<b>8675</b>	<b>9400</b>	<b>9750</b>	<b>9950</b>	<b>10825</b>	<b>11700</b>	<b>12850</b>
Options												
Economizer (Pa)	33	38	44	52	42	48	55	58	11	13	16	19
G4/F7 filtration (Pa)	148	164	181	208	175	197	219	230	123	136	150	169
Hot water coil (Pa)	31	35	40	47	38	44	50	54	24	27	31	36

Unit Size	070D				085D				100D			
<b>Airflow (m³/h)</b>	<b>12450</b>	<b>13550</b>	<b>14650</b>	<b>15090</b>	<b>14000</b>	<b>15125</b>	<b>16250</b>	<b>16725</b>	<b>17350</b>	<b>18875</b>	<b>20400</b>	<b>22450</b>
Options												
Economizer (Pa)	18	21	24	26	22	26	30	32	5	10	15	20
G4/F7 filtration (Pa)	162	181	200	208	188	209	230	239	135	150	166	187
Hot water coil (Pa)	34	39	44	47	41	47	53	55	23	26	30	35

### MODULES OF EXTRACTION

Airflows and pressure for the extraction fans for units with free-cooling:

Unit Size	020S-025S-030S			035S-040S-045D			055D-070D-085D			100D			
<b>Airflow (m³/h)</b>	<b>2000</b>	<b>2500</b>	<b>2750</b>	<b>3000</b>	<b>3500</b>	<b>4000</b>	<b>6000</b>	<b>7000</b>	<b>8000</b>	<b>13200</b>	<b>14300</b>	<b>15400</b>	<b>16500</b>
Available static pressure Pa.	160	105	75	210	180	130	260	200	90	230	200	150	50

**THERMODYNAMIC SECTION - VENTILATION DATA**

Table 3.16	CMC / CMH CSC / CSH 20 S	External static pressure	Pa	<b>35</b>	<b>47</b>	<b>101</b>	<b>151</b>	<b>178</b>	
		Airflow	m <sup>3</sup> /h	7600	7600	6100	5700	5300	
		Fan rotation speed	rpm	621	654	654	719	751	
		Fan motor power input	kW	1,11	1,20	0,86	0,93	0,92	
Table 3.17	CMC / CMH CSC / CSH 25 S	External static pressure	Pa	<b>40</b>	<b>63</b>	<b>107</b>	<b>148</b>	<b>223</b>	
		Airflow	m <sup>3</sup> /h	8500	8500	8500	6800	5950	
		Fan rotation speed	rpm	696	732	805	769	841	
		Fan motor power input	kW	1,56	1,68	1,93	1,31	1,3	
Table 3.18	CMC / CMH CSC / CSH 30 S	External static pressure	Pa	<b>36</b>	<b>55</b>	<b>106</b>	<b>146</b>	<b>272</b>	
		Airflow	m <sup>3</sup> /h	10000	10000	9000	8000	7000	
		Fan rotation speed	rpm	773	814	814	814	934	
		Fan motor power input	kW	2,33	2,51	2,12	1,79	1,89	
Table 3.19	CMC / CMH CSC / CSH 35 S	External static pressure	Pa	<b>50</b>	<b>107</b>	<b>152</b>	<b>209</b>		
		Airflow	m <sup>3</sup> /h	12850	12000	10800	8400		
		Fan rotation speed	rpm	613	677	709	741		
		Fan motor power input	kW	2,04	2,13	1,98	1,56		
Table 3.20	CMC / CMH CSC / CSH 40 S	External static pressure	Pa	<b>51</b>	<b>87</b>	<b>128</b>	<b>168</b>	<b>205</b>	
		Airflow	m <sup>3</sup> /h	12500	11700	10525	9350	8200	
		Fan rotation speed	rpm	613	645	677	709	741	
		Fan motor power input	kW	1,97	1,90	1,76	1,63	1,51	
Table 3.21	CMC / CMH CSC / CSH 45 D	External static pressure	Pa	<b>57</b>	<b>86</b>	<b>104</b>	<b>156</b>	<b>237</b>	
		Airflow	m <sup>3</sup> /h	14000	14000	12600	12600	9800	
		Fan rotation speed	rpm	686	758	722	794	829	
		Fan motor power input	kW	2,71	3,15	2,50	2,91	2,27	
Table 3.22	CMC / CMH CSC / CSH 55 D	External static pressure	Pa	<b>73</b>	<b>105</b>	<b>149</b>	<b>206</b>	<b>299</b>	
		Airflow	m <sup>3</sup> /h	20000	18000	16000	16000	14000	
		Fan rotation speed	rpm	645	613	613	677	741	
		Fan motor power input	kW	3,32	2,62	2,21	2,59	2,53	
Table 3.23	CMC / CMH CSC / CSH 70 D	External static pressure	Pa	<b>33</b>	<b>50</b>	<b>98</b>	<b>153</b>	<b>201</b>	<b>272</b>
		Airflow	m <sup>3</sup> /h	22400	22400	21000	18900	16800	14700
		Fan rotation speed	rpm	677	709	709	709	709	741
		Fan motor power input	kW	4,22	4,53	4,11	3,53	2,99	2,70
Table 3.24	CMC / CMH CSC / CSH 85 D	External static pressure	Pa	<b>36</b>	<b>51</b>	<b>101</b>	<b>154</b>	<b>277</b>	
		Airflow	m <sup>3</sup> /h	23500	23500	22000	15400	15400	
		Fan rotation speed	rpm	686	719	719	621	751	
		Fan motor power input	kW	4,62	4,98	4,51	2,14	2,93	
Table 3.25	CMC / CMH CSC / CSH 100 D	Section 1	External static pressure	Pa	<b>39</b>	<b>58</b>	<b>105</b>	<b>150</b>	<b>239</b>
			Airflow	m <sup>3</sup> /h	13950	16600	13950	12400	10850
			Fan rotation speed	rpm	666	801	756	756	846
			Fan motor power input	kW	2,60	4,45	3,14	2,65	2,68
Table 3.26	CMC / CMH CSC / CSH 100 D	Section 2	External static pressure	Pa	<b>46</b>	<b>70</b>	<b>101</b>	<b>148</b>	<b>201</b>
			Airflow	m <sup>3</sup> /h	10500	10525	12500	9350	8200
			Fan rotation speed	rpm	615	615	711	679	743
			Fan motor power input	kW	2,00	1,52	2,45	1,53	1,53

**COOLING CAPACITIES**

Table 4.1a

CMC - CMH 020 S			Outdoor temperature (dry bulb)																			
	Indoor wet bulb	Indoor dry bulb	20 °C			25 °C			30 °C			35 °C			40 °C			45 °C				
			GC	SC	AC	GC	SC	AC	GC	SC	AC	GC	SC	AC	GC	SC	AC	GC	SC	AC		
Minimum airflow rate	3150 m³/h	Evaporator air inlet temperature (°C)	16	21	19,4	11,8	4,2	18,9	11,5	4,5	18,3	11,2	4,9	17,5	10,9	5,3	16,7	10,5	6,0	15,7	10,0	6,8
				24	19,5	14,5	4,2	18,9	14,2	4,5	18,3	13,9	4,9	17,6	13,5	5,3	16,8	13,0	6,0	15,8	12,4	6,9
				27	19,6	16,9	4,2	19,1	16,5	4,5	18,5	16,2	4,9	17,8	15,7	5,4	17,0	15,2	6,0	16,1	14,5	6,9
			19	24	21,2	11,5	4,3	20,6	11,3	4,6	19,9	11,0	5,0	19,1	10,7	5,5	18,2	10,3	6,1	17,2	9,9	7,0
				27	21,2	14,4	4,3	20,6	14,1	4,6	19,9	13,8	5,0	19,1	13,4	5,5	18,3	13,0	6,1	17,3	12,4	7,0
				30	21,3	16,8	4,3	20,7	16,5	4,6	20,1	16,1	5,0	19,3	15,7	5,5	18,4	15,2	6,2	17,4	14,6	7,0
			22	27	23,2	10,9	4,5	22,6	10,7	4,8	21,8	10,5	5,2	20,9	10,2	5,7	20,0	9,9	6,3	18,9	9,6	7,2
				30	23,2	13,9	4,5	22,5	13,7	4,8	21,8	13,4	5,2	20,9	13,1	5,7	20,0	12,7	6,3	18,9	12,3	7,2
				33	23,2	16,4	4,5	22,6	16,2	4,8	21,9	15,8	5,2	21,0	15,5	5,7	20,1	15,0	6,3	19,1	14,5	7,2
Nominal airflow rate	3700 m³/h	16	21	20,0	12,4	4,3	19,4	12,1	4,6	18,7	11,8	5,0	18,0	11,4	5,4	17,1	11,0	6,1	16,1	10,6	7,0	
			24	20,0	15,4	4,3	19,5	15,1	4,6	18,8	14,7	5,0	18,1	14,3	5,5	17,2	13,7	6,1	16,3	13,2	7,0	
			27	20,3	18,0	4,3	19,7	17,6	4,6	19,1	17,2	5,0	18,4	16,7	5,5	17,5	16,2	6,1	16,6	15,5	7,0	
		19	24	21,7	12,2	4,4	21,1	11,9	4,7	20,4	11,6	5,1	19,5	11,3	5,6	18,6	11,0	6,2	17,6	10,5	7,1	
			27	21,8	15,3	4,4	21,2	15,0	4,7	20,4	14,7	5,1	19,6	14,3	5,6	18,7	13,8	6,3	17,7	13,2	7,2	
			30	22,0	17,9	4,4	21,4	17,6	4,7	20,7	17,2	5,1	19,9	16,8	5,6	19,0	16,2	6,3	17,9	15,6	7,2	
		22	27	23,7	11,6	4,5	23,1	11,4	4,9	22,3	11,2	5,3	21,4	10,9	5,8	20,4	10,6	6,4	19,2	10,3	7,3	
			30	23,8	14,9	4,5	23,1	14,6	4,9	22,3	14,3	5,3	21,4	14,0	5,8	20,4	13,6	6,4	19,3	13,1	7,4	
			33	23,9	17,6	4,6	23,2	17,4	4,9	22,5	17,0	5,3	21,6	16,6	5,8	20,6	16,1	6,5	19,5	15,6	7,4	
Maximum airflow rate	4100 m³/h	16	21	20,3	12,6	4,2	19,8	12,3	4,5	19,1	12,0	4,9	18,3	11,6	5,4	17,4	11,2	6,0	16,4	10,7	6,8	
			24	20,5	15,7	4,2	19,9	15,4	4,5	19,2	15,0	4,9	18,5	14,6	5,4	17,6	14,1	6,0	16,6	13,5	6,8	
			27	20,8	18,5	4,3	20,2	18,1	4,6	19,5	17,7	4,9	18,8	17,2	5,4	17,9	16,6	6,0	16,9	16,0	6,9	
		19	24	22,1	12,4	4,4	21,5	12,1	4,7	20,7	11,8	5,0	19,9	11,5	5,5	18,9	11,1	6,1	17,8	10,7	7,0	
			27	22,2	15,7	4,4	21,6	15,4	4,7	20,8	15,0	5,1	20,0	14,6	5,5	19,1	14,1	6,2	18,0	13,6	7,0	
			30	22,5	18,5	4,4	21,8	18,2	4,7	21,1	17,8	5,1	20,3	17,3	5,6	19,4	16,7	6,2	18,3	16,1	7,0	
		22	27	24,1	11,8	4,5	23,4	11,6	4,8	22,6	11,4	5,2	21,7	11,1	5,7	20,6	10,8	6,3	19,5	10,5	7,2	
			30	24,2	15,3	4,5	23,5	15,0	4,8	22,7	14,7	5,2	21,8	14,4	5,7	20,8	14,0	6,4	19,7	13,5	7,2	
			33	24,4	18,2	4,5	23,7	17,9	4,9	22,9	17,6	5,3	22,0	17,1	5,7	21,0	16,7	6,4	19,9	16,1	7,3	

**HEATING CAPACITIES**

Table 4.1b

CMH/CSH+CIH 020 S			Outdoor temperature (dry bulb)													
	Condenser air inlet temperature (dry bulb) °C		-10 °C		-5 °C		0 °C		5 °C		7 °C		10 °C		15 °C	
			GH	AC	GH	AC	GH	AC	GH	AC	GH	AC	GH	AC	GH	AC
Minimum airflow rate	3150 m³/h	15	12,46	3,36	14,47	3,74	16,46	4,11	18,43	4,48	19,22	4,63	20,39	4,85	22,34	5,24
		18	12,46	3,66	14,42	4,05	16,37	4,43	18,30	4,81	19,07	4,96	20,22	5,20	22,12	5,61
		20	12,47	3,87	14,40	4,26	16,32	4,65	18,22	5,04	18,98	5,20	20,11	5,44	21,99	5,87
		23	12,49	4,21	14,38	4,61	16,25	5,00	18,11	5,41	18,86	5,58	19,96	5,84	21,80	6,29
		25	12,51	4,45	14,37	4,85	16,22	5,25	18,05	5,67	18,78	5,85	19,87	6,12	21,67	6,60
		27	12,54	4,69	14,37	5,10	16,19	5,51	17,99	5,95	18,71	6,13	19,78	6,41	21,56	6,92
Nominal airflow rate	3700 m³/h	15	12,60	3,27	14,65	3,62	16,68	3,96	18,70	4,30	19,50	4,43	20,70	4,64	22,70	4,99
		19	12,59	3,67	14,58	4,02	16,55	4,37	18,52	4,72	19,30	4,86	20,46	5,08	22,40	5,45
		20	12,59	3,77	14,57	4,13	16,53	4,48	18,47	4,83	19,25	4,98	20,41	5,20	22,33	5,58
		23	12,60	4,10	14,53	4,46	16,45	4,82	18,36	5,19	19,12	5,34	20,25	5,57	22,12	5,97
		25	12,62	4,34	14,52	4,70	16,41	5,06	18,29	5,44	19,03	5,59	20,15	5,83	22,00	6,26
		27	12,64	4,58	14,51	4,95	16,37	5,32	18,22	5,70	18,96	5,86	20,05	6,11	21,87	6,55
Maximum airflow rate	4100 m³/h	15	12,62	3,14	14,70	3,47	16,76	3,80	18,81	4,11	19,63	4,24	20,85	4,43	22,87	4,76
		19	12,60	3,52	14,62	3,86	16,63	4,19	18,62	4,52	19,42	4,65	20,60	4,85	22,57	5,20
		20	12,60	3,63	14,61	3,97	16,60	4,30	18,58	4,63	19,37	4,76	20,54	4,97	22,50	5,32
		23	12,60	3,95	14,57	4,29	16,52	4,63	18,45	4,97	19,22	5,11	20,38	5,32	22,29	5,69
		25	12,61	4,18	14,55	4,52	16,47	4,86	18,38	5,21	19,14	5,35	20,27	5,57	22,15	5,96
		27	12,63	4,42	14,54	4,76	16,43	5,10	18,31	5,46	19,06	5,60	20,17	5,83	22,02	6,23

<b>Indoor fan power input (kw)</b>			
Minimum airflow rate	0,31	Nominal airflow rate	0,38
Maximum airflow rate	0,44		
<b>Outdoor fan power input (kw)</b>			
Nominal airflow rate	1,28		

<b>GC (kW)</b> :	Gross cooling capacity	<b>GH (kW)</b> :	Gross heating capacity	<b>SC (kW)</b> :	Sensible cooling capacity	<b>AC (kW)</b> :	Compressor absorbed power
------------------	------------------------	------------------	------------------------	------------------	---------------------------	------------------	---------------------------



**COOLING CAPACITIES**

Table 4.2a

CMC - CMH025 S			Outdoor temperature (dry bulb)																		
	Indoor wet bulb	Indoor dry bulb	20 °C			25 °C			30 °C			35 °C			40 °C			45 °C			
			GC	SC	AC	GC	SC	AC	GC	SC	AC	GC	SC	AC	GC	SC	AC	GC	SC	AC	
Minimum airflow rate 4250 m³/h	Evaporator air inlet temperature (°C)	16	21	24,5	14,6	5,0	23,8	14,3	5,4	23,1	14,0	5,8	22,2	13,6	6,4	21,2	13,1	7,1	20,1	12,6	8,1
			24	24,5	18,2	5,0	23,9	17,9	5,4	23,2	17,4	5,8	22,3	16,9	6,4	21,3	16,4	7,1	20,2	15,7	8,1
			27	24,7	21,2	5,0	24,1	20,8	5,4	23,4	20,4	5,8	22,6	19,8	6,4	21,6	19,2	7,1	20,5	18,4	8,1
		19	24	26,7	14,3	5,1	26,0	14,0	5,5	25,2	13,7	5,9	24,2	13,3	6,5	23,1	12,9	7,2	21,9	12,4	8,2
			27	26,7	18,1	5,1	26,0	17,7	5,5	25,2	17,3	5,9	24,2	16,9	6,5	23,2	16,4	7,2	22,0	15,7	8,2
			30	26,9	21,1	5,1	26,2	20,8	5,5	25,4	20,4	6,0	24,4	19,8	6,5	23,4	19,2	7,2	22,2	18,5	8,2
		22	27	29,2	13,5	5,3	28,4	13,3	5,7	27,5	13,0	6,1	26,5	12,7	6,7	25,3	12,4	7,4	24,0	12,0	8,4
			30	29,1	17,5	5,3	28,4	17,2	5,7	27,5	16,8	6,1	26,4	16,4	6,7	25,3	16,0	7,4	24,0	15,4	8,4
			33	29,2	20,7	5,3	28,5	20,4	5,7	27,6	20,0	6,1	26,6	19,5	6,7	25,5	19,0	7,4	24,2	18,4	8,4
Nominal airflow rate 5000 m³/h	Evaporator air inlet temperature (°C)	16	21	25,0	15,4	5,2	24,3	15,0	5,6	23,5	14,7	6,0	22,6	14,2	6,6	21,5	13,7	7,3	20,4	13,2	8,4
			24	25,1	19,2	5,2	24,4	18,8	5,6	23,7	18,4	6,0	22,8	17,8	6,6	21,7	17,2	7,4	20,6	16,5	8,4
			27	25,4	22,5	5,2	24,8	22,1	5,6	24,0	21,6	6,1	23,1	21,0	6,6	22,1	20,3	7,4	21,0	19,5	8,4
		19	24	27,2	15,1	5,3	26,5	14,8	5,7	25,6	14,5	6,2	24,6	14,1	6,7	23,4	13,6	7,5	22,2	13,1	8,5
			27	27,3	19,1	5,3	26,5	18,8	5,7	25,7	18,4	6,2	24,7	17,9	6,7	23,6	17,3	7,5	22,3	16,6	8,5
			30	27,5	22,5	5,4	26,8	22,1	5,7	26,0	21,7	6,2	25,0	21,1	6,8	23,9	20,4	7,5	22,7	19,7	8,6
		22	27	29,7	14,4	5,5	28,9	14,1	5,9	27,9	13,9	6,3	26,8	13,5	6,9	25,6	13,2	7,7	24,3	12,8	8,7
			30	29,7	18,6	5,5	28,9	18,3	5,9	27,9	18,0	6,4	26,9	17,5	6,9	25,7	17,0	7,7	24,4	16,5	8,8
			33	29,9	22,1	5,5	29,1	21,8	5,9	28,2	21,4	6,4	27,1	20,9	7,0	25,9	20,3	7,7	24,6	19,6	8,8
Maximum airflow rate 5500 m³/h	Evaporator air inlet temperature (°C)	16	21	25,5	15,4	5,1	24,8	15,1	5,5	23,9	14,8	5,9	23,0	14,3	6,4	21,9	13,8	7,1	20,7	13,3	8,0
			24	25,6	19,5	5,1	25,0	19,1	5,5	24,2	18,7	5,9	23,2	18,1	6,4	22,2	17,5	7,1	21,0	16,8	8,0
			27	26,0	23,0	5,2	25,3	22,6	5,5	24,6	22,1	5,9	23,6	21,5	6,5	22,6	20,8	7,1	21,4	20,0	8,1
		19	24	27,7	15,2	5,3	26,9	14,9	5,6	26,0	14,6	6,0	25,0	14,2	6,6	23,8	13,8	7,3	22,5	13,3	8,2
			27	27,8	19,4	5,3	27,0	19,1	5,6	26,2	18,7	6,1	25,1	18,2	6,6	24,0	17,6	7,3	22,7	16,9	8,2
			30	28,1	23,0	5,3	27,4	22,6	5,7	26,5	22,2	6,1	25,5	21,6	6,6	24,4	20,9	7,3	23,1	20,2	8,3
		22	27	30,2	14,5	5,5	29,3	14,2	5,8	28,3	14,0	6,2	27,2	13,7	6,8	26,0	13,3	7,5	24,6	12,9	8,5
			30	30,2	18,9	5,5	29,4	18,6	5,8	28,4	18,3	6,3	27,3	17,9	6,8	26,1	17,4	7,5	24,8	16,8	8,5
			33	30,5	22,7	5,5	29,6	22,3	5,8	28,7	21,9	6,3	27,6	21,4	6,8	26,4	20,8	7,5	25,1	20,1	8,5

**HEATING CAPACITIES**

Table 4.2b

CMH/CSH+CIH 025 S			Outdoor temperature (dry bulb)													
	Condenser air inlet temperature (dry bulb) °C		-10 °C		-5 °C		0 °C		5 °C		7 °C		10 °C		15 °C	
			GH	AC	GH	AC	GH	AC	GH	AC	GH	AC	GH	AC	GH	AC
Minimum airflow rate 4250 m³/h		15	16,09	4,22	18,64	4,64	21,18	5,05	23,69	5,45	24,70	5,62	26,19	5,87	28,67	6,30
		18	16,07	4,58	18,58	5,00	21,07	5,42	23,55	5,85	24,53	6,02	26,00	6,28	28,44	6,74
		20	16,06	4,83	18,55	5,26	21,01	5,69	23,46	6,13	24,43	6,31	25,88	6,58	28,29	7,06
		23	16,07	5,25	18,51	5,69	20,93	6,13	23,33	6,59	24,29	6,78	25,72	7,07	28,08	7,58
		25	16,08	5,55	18,49	5,99	20,89	6,45	23,26	6,92	24,20	7,12	25,61	7,42	27,95	7,96
27	16,10	5,87	18,48	6,32	20,85	6,79	23,19	7,28	24,12	7,48	25,52	7,80	27,82	8,37		
Nominal airflow rate 5000 m³/h		15	16,52	4,24	19,12	4,61	21,71	4,97	24,27	5,33	25,29	5,48	26,82	5,70	29,34	6,08
		19	16,48	4,72	19,02	5,09	21,55	5,46	24,06	5,84	25,06	5,99	26,55	6,23	29,01	6,64
		20	16,47	4,84	19,00	5,22	21,51	5,59	24,01	5,97	25,00	6,13	26,48	6,37	28,94	6,80
		23	16,46	5,25	18,95	5,63	21,42	6,01	23,87	6,41	24,84	6,58	26,30	6,83	28,71	7,28
		25	16,46	5,55	18,92	5,93	21,36	6,31	23,78	6,72	24,75	6,90	26,18	7,16	28,57	7,63
27	16,46	5,86	18,90	6,24	21,31	6,64	23,70	7,06	24,66	7,24	26,08	7,52	28,43	8,01		
Maximum airflow rate 5500 m³/h		15	16,59	4,11	19,23	4,45	21,84	4,79	24,44	5,13	25,47	5,26	27,02	5,47	29,57	5,83
		19	16,53	4,57	19,11	4,91	21,67	5,26	24,21	5,61	25,22	5,75	26,73	5,97	29,23	6,36
		20	16,52	4,69	19,08	5,04	21,63	5,38	24,15	5,74	25,16	5,88	26,66	6,11	29,15	6,50
		23	16,50	5,09	19,02	5,43	21,52	5,78	24,00	6,15	24,99	6,30	26,47	6,54	28,91	6,95
		25	16,49	5,37	18,98	5,71	21,46	6,07	23,91	6,45	24,89	6,60	26,35	6,85	28,76	7,28
27	16,49	5,67	18,95	6,01	21,40	6,38	23,82	6,76	24,79	6,92	26,23	7,18	28,62	7,63		

<b>Indoor fan power input (kw)</b>			
Minimum airflow rate	0,54	Nominal airflow rate	0,69
Maximum airflow rate	0,80		
<b>Outdoor fan power input (kw)</b>			
Nominal airflow rate	1,80		

<b>GC (kW)</b> :	Gross cooling capacity	<b>GH (kW)</b> :	Gross heating capacity	<b>SC (kW)</b> :	Sensible cooling capacity	<b>AC (kW)</b> :	Compressor absorbed power
------------------	------------------------	------------------	------------------------	------------------	---------------------------	------------------	---------------------------

**COOLING CAPACITIES**

Table 4.3a

CMC - CMH030 S			Outdoor temperature (dry bulb)																			
	Indoor wet bulb	Indoor dry bulb	20 °C			25 °C			30 °C			35 °C			40 °C			45 °C				
			GC	SC	AC	GC	SC	AC	GC	SC	AC	GC	SC	AC	GC	SC	AC	GC	SC	AC		
Minimum airflow rate	4650 m <sup>3</sup> /h	Evaporator air inlet temperature (°C)	16	21	27,7	16,4	5,5	27,0	16,1	5,9	26,0	15,6	6,4	25,0	15,1	7,1	23,7	14,5	8,0	22,3	13,9	9,2
				24	27,8	20,1	5,5	27,1	19,7	5,9	26,2	19,2	6,5	25,1	18,7	7,1	23,9	18,0	8,0	22,5	17,2	9,2
				27	27,9	23,6	5,5	27,2	23,2	5,9	26,3	22,7	6,5	25,3	22,0	7,1	24,0	21,3	8,0	22,6	20,3	9,2
			19	24	30,2	16,2	5,6	29,4	15,8	6,1	28,4	15,4	6,6	27,2	14,9	7,2	25,9	14,4	8,1	24,4	13,8	9,3
				27	30,3	19,9	5,6	29,5	19,5	6,1	28,5	19,0	6,6	27,3	18,5	7,3	26,0	17,9	8,1	24,5	17,1	9,3
				30	30,4	23,3	5,6	29,6	23,0	6,1	28,6	22,5	6,6	27,5	21,9	7,3	26,2	21,2	8,1	24,7	20,3	9,4
			22	27	32,9	15,7	5,8	32,0	15,3	6,2	30,9	14,9	6,8	29,7	14,5	7,4	28,2	14,0	8,3	26,7	13,5	9,5
				30	33,0	19,4	5,8	32,1	19,0	6,2	31,0	18,6	6,8	29,8	18,1	7,4	28,4	17,6	8,3	26,8	16,9	9,5
				33	33,1	22,9	5,8	32,2	22,5	6,2	31,1	22,1	6,8	29,9	21,5	7,4	28,5	20,9	8,3	26,9	20,2	9,5
Nominal airflow rate	5450 m <sup>3</sup> /h	16	21	28,4	17,2	5,7	27,6	16,9	6,1	26,6	16,4	6,6	25,4	15,9	7,3	24,1	15,3	8,2	22,7	14,6	9,5	
			24	28,5	21,4	5,7	27,7	21,0	6,1	26,7	20,5	6,7	25,6	19,9	7,3	24,3	19,1	8,2	22,8	18,3	9,5	
			27	28,6	25,3	5,7	27,8	24,9	6,1	26,9	24,4	6,7	25,7	23,7	7,3	24,5	22,8	8,2	23,0	21,8	9,5	
		19	24	30,9	16,9	5,8	30,0	16,5	6,3	29,0	16,1	6,8	27,7	15,6	7,5	26,3	15,1	8,4	24,8	14,5	9,6	
			27	31,0	21,1	5,8	30,1	20,7	6,3	29,1	20,3	6,8	27,9	19,7	7,5	26,5	19,0	8,4	24,9	18,3	9,6	
			30	31,1	25,1	5,8	30,2	24,7	6,3	29,2	24,2	6,8	28,0	23,6	7,5	26,6	22,8	8,4	25,1	21,9	9,7	
		22	27	33,6	16,3	6,0	32,7	16,0	6,4	31,5	15,6	7,0	30,2	15,2	7,7	28,8	14,7	8,6	27,1	14,2	9,8	
			30	33,7	20,6	6,0	32,8	20,3	6,4	31,6	19,8	7,0	30,3	19,3	7,7	28,9	18,8	8,6	27,3	18,1	9,9	
			33	33,8	24,6	6,0	32,9	24,3	6,4	31,8	23,8	7,0	30,5	23,3	7,7	29,0	22,6	8,6	27,4	21,8	9,9	
Maximum airflow rate	6000 m <sup>3</sup> /h	16	21	28,9	17,3	5,6	28,1	17,0	6,0	27,1	16,6	6,5	25,9	16,1	7,1	24,6	15,5	7,9	23,1	14,8	9,1	
			24	29,0	21,9	5,6	28,2	21,5	6,0	27,2	21,0	6,5	26,1	20,4	7,1	24,8	19,6	7,9	23,3	18,8	9,1	
			27	29,2	26,2	5,6	28,4	25,7	6,0	27,4	25,2	6,5	26,2	24,5	7,1	24,9	23,6	7,9	23,4	22,7	9,1	
		19	24	31,5	16,9	5,7	30,6	16,6	6,1	29,5	16,2	6,6	28,2	15,7	7,3	26,8	15,2	8,1	25,2	14,6	9,3	
			27	31,6	21,5	5,7	30,7	21,2	6,1	29,6	20,7	6,6	28,4	20,1	7,3	27,0	19,5	8,1	25,4	18,7	9,3	
			30	31,7	25,9	5,7	30,8	25,5	6,1	29,8	25,0	6,7	28,5	24,4	7,3	27,1	23,6	8,1	25,6	22,6	9,3	
		22	27	34,3	16,2	5,9	33,3	15,9	6,3	32,1	15,6	6,8	30,8	15,2	7,5	29,3	14,8	8,3	27,6	14,2	9,5	
			30	34,4	20,9	5,9	33,4	20,6	6,3	32,2	20,2	6,8	30,9	19,7	7,5	29,4	19,1	8,3	27,7	18,5	9,5	
			33	34,5	25,3	5,9	33,5	25,0	6,3	32,3	24,5	6,9	31,0	24,0	7,5	29,5	23,3	8,4	27,9	22,5	9,5	

**HEATING CAPACITIES**

Table 4.3b

CMH/CSH+CIH 030 S			Outdoor temperature (dry bulb)													
Condenser air inlet temperature (dry bulb) °C			-10 °C		-5 °C		0 °C		5 °C		7 °C		10 °C		15 °C	
			GH	AC	GH	AC	GH	AC	GH	AC	GH	AC	GH	AC	GH	AC
Minimum airflow rate	4650 m <sup>3</sup> /h	15	19,25	4,76	22,30	5,33	25,28	5,87	28,18	6,40	29,32	6,60	31,01	6,92	33,76	7,46
		18	19,19	5,19	22,16	5,76	25,06	6,31	27,89	6,86	29,00	7,08	30,64	7,41	33,32	7,98
		20	19,15	5,48	22,07	6,07	24,92	6,63	27,70	7,18	28,79	7,41	30,40	7,75	33,03	8,35
		23	19,09	5,96	21,94	6,55	24,71	7,12	27,42	7,71	28,48	7,94	30,04	8,31	32,60	8,94
		25	19,05	6,29	21,85	6,89	24,58	7,48	27,23	8,08	28,27	8,32	29,81	8,70	32,32	9,37
		27	19,02	6,63	21,77	7,24	24,44	7,85	27,05	8,47	28,07	8,72	29,58	9,12	32,03	9,82
Nominal airflow rate	5450 m <sup>3</sup> /h	15	19,68	4,73	22,82	5,25	25,88	5,74	28,87	6,22	30,04	6,41	31,78	6,70	34,62	7,19
		19	19,59	5,30	22,62	5,83	25,58	6,33	28,47	6,83	29,61	7,03	31,29	7,33	34,03	7,85
		20	19,56	5,45	22,57	5,98	25,51	6,48	28,37	6,98	29,50	7,19	31,17	7,50	33,88	8,03
		23	19,50	5,92	22,44	6,45	25,30	6,97	28,09	7,49	29,18	7,70	30,80	8,02	33,45	8,59
		25	19,46	6,26	22,35	6,79	25,16	7,31	27,90	7,84	28,97	8,06	30,56	8,40	33,16	8,98
		27	19,42	6,60	22,26	7,13	25,02	7,67	27,71	8,22	28,77	8,44	30,33	8,79	32,87	9,41
Maximum airflow rate	6000 m <sup>3</sup> /h	15	19,76	4,51	22,96	5,02	26,08	5,49	29,12	5,94	30,32	6,12	32,10	6,39	35,00	6,85
		19	19,66	5,07	22,75	5,57	25,78	6,05	28,72	6,51	29,88	6,70	31,60	6,98	34,40	7,47
		20	19,64	5,22	22,71	5,72	25,70	6,19	28,62	6,66	29,77	6,85	31,47	7,14	34,25	7,63
		23	19,57	5,67	22,56	6,17	25,48	6,66	28,33	7,14	29,45	7,34	31,11	7,64	33,81	8,16
		25	19,52	5,99	22,47	6,49	25,34	6,98	28,14	7,47	29,24	7,68	30,87	7,99	33,52	8,53
		27	19,49	6,33	22,38	6,82	25,20	7,32	27,95	7,83	29,03	8,03	30,63	8,36	33,23	8,92

INDOOR FAN POWER INPUT (kW)			
Minimum airflow rate	0,68	Nominal airflow rate	0,86
Maximum airflow rate	1		
OUTDOOR FAN POWER INPUT (kW)			
Nominal airflow rate	2,68		

<b>GC (kW)</b> :	Gross cooling capacity	<b>GH (kW)</b> :	Gross heating capacity	<b>SC (kW)</b> :	Sensible cooling capacity	<b>AC (kW)</b> :	Compressor absorbed power
------------------	------------------------	------------------	------------------------	------------------	---------------------------	------------------	---------------------------

**COOLING CAPACITIES**

Table 4.4a

CMC - CMH035 S			Outdoor temperature (dry bulb)																			
	Indoor wet bulb	Indoor dry bulb	20 °C			25 °C			30 °C			35 °C			40 °C			45 °C				
			GC	SC	AC	GC	SC	AC	GC	SC	AC	GC	SC	AC	GC	SC	AC	GC	SC	AC		
Minimum airflow rate	6200 m³/h	Evaporator air inlet temperature (°C)	16	21	36,1	21,9	7,9	35,1	21,5	8,5	34,0	20,9	9,2	32,6	20,3	10,0	31,1	19,6	11,2	29,3	18,7	12,8
				24	36,2	27,3	7,9	35,3	26,8	8,5	34,1	26,1	9,2	32,8	25,4	10,0	31,3	24,5	11,2	29,6	23,4	12,9
				27	36,5	31,8	8,0	35,6	31,3	8,5	34,5	30,6	9,2	33,2	29,7	10,1	31,7	28,7	11,3	30,0	27,5	12,9
			19	24	39,2	21,5	8,2	38,1	21,1	8,7	36,9	20,6	9,4	35,4	20,0	10,3	33,7	19,4	11,4	31,8	18,6	13,1
				27	39,2	27,1	8,2	38,2	26,6	8,7	36,9	26,0	9,4	35,5	25,3	10,3	33,8	24,5	11,5	32,0	23,5	13,1
				30	39,5	31,8	8,2	38,5	31,3	8,7	37,3	30,6	9,4	35,8	29,8	10,3	34,2	28,9	11,5	32,4	27,8	13,2
			22	27	42,8	20,3	8,4	41,6	19,9	9,0	40,2	19,6	9,7	38,6	19,1	10,6	36,8	18,6	11,7	34,8	18,0	13,4
				30	42,7	26,3	8,4	41,6	25,9	9,0	40,2	25,4	9,7	38,6	24,7	10,6	36,8	24,0	11,7	34,8	23,2	13,4
				33	42,9	31,2	8,4	41,7	30,8	9,0	40,4	30,2	9,7	38,8	29,5	10,6	37,1	28,6	11,8	35,1	27,6	13,4
Nominal airflow rate	7100 m³/h	Evaporator air inlet temperature (°C)	16	21	36,6	22,8	8,2	35,6	22,3	8,8	34,4	21,7	9,5	33,1	21,1	10,3	31,5	20,3	11,5	29,7	19,4	13,2
				24	36,8	28,6	8,3	35,8	28,0	8,8	34,6	27,4	9,5	33,3	26,5	10,4	31,7	25,6	11,5	30,0	24,5	13,2
				27	37,1	33,6	8,3	36,2	33,0	8,9	35,1	32,3	9,6	33,8	31,3	10,4	32,2	30,3	11,6	30,5	29,0	13,3
			19	24	39,8	22,4	8,5	38,7	21,9	9,0	37,4	21,4	9,7	35,8	20,9	10,6	34,1	20,2	11,8	32,2	19,4	13,4
				27	39,9	28,5	8,5	38,8	28,0	9,0	37,5	27,4	9,7	36,0	26,6	10,6	34,3	25,7	11,8	32,4	24,7	13,5
				30	40,2	33,7	8,5	39,1	33,1	9,1	37,8	32,4	9,8	36,4	31,6	10,7	34,7	30,5	11,9	32,8	29,3	13,5
			22	27	43,4	21,2	8,7	42,1	20,9	9,3	40,7	20,5	10,0	39,1	20,0	10,9	37,2	19,5	12,1	35,2	18,8	13,7
				30	43,4	27,7	8,7	42,2	27,3	9,3	40,7	26,7	10,0	39,1	26,1	10,9	37,3	25,3	12,1	35,3	24,4	13,8
				33	43,6	33,2	8,7	42,4	32,7	9,3	41,0	32,1	10,0	39,4	31,3	10,9	37,6	30,4	12,1	35,6	29,3	13,8
Maximum airflow rate	8050 m³/h	Evaporator air inlet temperature (°C)	16	21	37,9	22,8	7,8	36,9	22,4	8,2	35,7	21,8	8,7	34,2	21,2	9,4	32,6	20,5	10,3	30,7	19,6	11,5
				24	38,1	29,2	7,8	37,1	28,7	8,3	35,9	28,0	8,8	34,5	27,2	9,5	32,9	26,3	10,4	31,1	25,1	11,6
				27	38,6	34,8	7,9	37,6	34,2	8,3	36,4	33,5	8,9	35,0	32,5	9,6	33,4	31,4	10,5	31,7	30,1	11,7
			19	24	41,1	22,3	8,0	40,0	21,9	8,5	38,6	21,4	9,0	37,0	20,9	9,7	35,3	20,2	10,6	33,3	19,5	11,9
				27	41,2	29,1	8,0	40,1	28,6	8,5	38,8	27,9	9,1	37,2	27,2	9,8	35,5	26,3	10,7	33,6	25,3	11,9
				30	41,6	34,9	8,1	40,5	34,3	8,5	39,2	33,6	9,1	37,7	32,7	9,8	36,0	31,7	10,8	34,0	30,5	12,0
			22	27	44,7	21,0	8,3	43,4	20,7	8,8	42,0	20,4	9,3	40,3	20,0	10,0	38,4	19,4	11,0	36,3	18,8	12,3
				30	44,8	28,2	8,3	43,5	27,8	8,8	42,1	27,3	9,3	40,4	26,6	10,1	38,5	25,9	11,0	36,5	25,0	12,3
				33	45,0	34,2	8,3	43,8	33,7	8,8	42,4	33,1	9,4	40,7	32,3	10,1	38,9	31,4	11,1	36,8	30,3	12,4

**HEATING CAPACITIES**

Table 4.4b

CMH/CSH+CIH 035 S			Outdoor temperature (dry bulb)													
	Condenser air inlet temperature (dry bulb) °C		-10 °C		-5 °C		0 °C		5 °C		7 °C		10 °C		15 °C	
			GH	AC	GH	AC	GH	AC	GH	AC	GH	AC	GH	AC	GH	AC
Minimum airflow rate	6200 m³/h	15	23,49	6,21	27,16	6,91	30,77	7,58	34,32	8,23	35,72	8,48	37,81	8,87	41,24	9,53
		18	23,43	6,66	27,02	7,39	30,56	8,08	34,03	8,76	35,41	9,03	37,45	9,44	40,80	10,15
		20	23,39	6,97	26,93	7,71	30,42	8,42	33,84	9,13	35,19	9,41	37,20	9,85	40,51	10,59
		23	23,33	7,44	26,80	8,21	30,20	8,96	33,55	9,71	34,87	10,02	36,84	10,48	40,07	11,28
		25	23,28	7,77	26,70	8,56	30,06	9,34	33,36	10,12	34,66	10,44	36,59	10,93	39,77	11,77
27	23,24	8,09	26,61	8,91	29,91	9,72	33,16	10,54	34,44	10,87	36,35	11,39	39,47	12,29		
Nominal airflow rate	7100 m³/h	15	24,03	6,29	27,78	6,94	31,47	7,55	35,09	8,14	36,53	8,37	38,66	8,73	42,16	9,33
		19	23,96	6,91	27,60	7,58	31,19	8,22	34,71	8,85	36,11	9,10	38,18	9,48	41,58	10,14
		20	23,94	7,07	27,56	7,75	31,12	8,40	34,62	9,04	36,00	9,29	38,06	9,68	41,44	10,35
		23	23,87	7,56	27,42	8,26	30,90	8,94	34,33	9,61	35,68	9,89	37,69	10,30	41,00	11,02
		25	23,83	7,90	27,33	8,61	30,76	9,31	34,13	10,02	35,47	10,30	37,45	10,74	40,70	11,50
27	23,79	8,24	27,23	8,97	30,61	9,70	33,94	10,43	35,25	10,73	37,20	11,19	40,40	11,99		
Maximum airflow rate	8050 m³/h	15	24,04	5,95	27,87	6,56	31,63	7,12	35,34	7,67	36,81	7,89	38,99	8,21	42,58	8,76
		19	23,97	6,55	27,69	7,18	31,36	7,77	34,96	8,34	36,39	8,57	38,51	8,92	41,99	9,51
		20	23,95	6,71	27,65	7,34	31,29	7,93	34,87	8,52	36,28	8,75	38,39	9,10	41,85	9,70
		23	23,88	7,19	27,51	7,83	31,07	8,45	34,58	9,06	35,96	9,31	38,02	9,68	41,41	10,32
		25	23,84	7,51	27,42	8,17	30,93	8,80	34,39	9,44	35,75	9,69	37,78	10,08	41,12	10,76
27	23,80	7,84	27,32	8,51	30,79	9,16	34,19	9,82	35,54	10,09	37,53	10,50	40,82	11,21		

**INDOOR FAN POWER INPUT (kW)**

Minimum airflow rate	0,82	Nominal airflow rate	0,99	Maximum airflow rate	1,20
----------------------	------	----------------------	------	----------------------	------

**OUTDOOR FAN POWER INPUT (kW)**

Nominal airflow rate	2,13
----------------------	------

<b>GC (kW)</b> :	Gross cooling capacity	<b>GH (kW)</b> :	Gross heating capacity	<b>SC (kW)</b> :	Sensible cooling capacity	<b>AC (kW)</b> :	Compressor absorbed power
------------------	------------------------	------------------	------------------------	------------------	---------------------------	------------------	---------------------------

**COOLING CAPACITIES**

Table 4.5a

CMC - CMH040 S			Outdoor temperature (dry bulb)																			
	Indoor wet bulb	Indoor dry bulb	20 °C			25 °C			30 °C			35 °C			40 °C			45 °C				
			GC	SC	AC	GC	SC	AC	GC	SC	AC	GC	SC	AC	GC	SC	AC	GC	SC	AC		
Minimum airflow rate	6950 m <sup>3</sup> /h	Evaporator air inlet temperature (°C)	16	21	42,1	24,7	9,1	41,0	24,2	9,7	39,6	23,5	10,5	38,0	22,8	11,5	36,1	21,9	12,9	33,9	20,8	14,9
				24	42,1	30,5	9,1	41,1	29,9	9,8	39,7	29,2	10,5	38,1	28,3	11,6	36,2	27,2	13,0	34,1	25,9	15,0
				27	42,4	35,6	9,1	41,3	35,0	9,8	40,0	34,2	10,6	38,4	33,2	11,6	36,6	31,9	13,0	34,5	30,5	15,0
			19	24	45,8	24,2	9,4	44,5	23,7	10,0	43,0	23,1	10,8	41,2	22,4	11,8	39,1	21,6	13,2	36,8	20,6	15,2
				27	45,8	30,2	9,4	44,6	29,6	10,0	43,1	28,9	10,8	41,3	28,1	11,8	39,2	27,1	13,2	36,9	25,9	15,3
				30	46,0	35,4	9,4	44,8	34,8	10,0	43,3	34,0	10,8	41,6	33,1	11,9	39,5	31,9	13,3	37,2	30,6	15,3
			22	27	50,0	22,9	9,6	48,5	22,5	10,3	46,8	22,0	11,1	44,9	21,4	12,2	42,6	20,8	13,6	40,1	20,0	15,6
				30	49,9	29,2	9,6	48,5	28,7	10,3	46,8	28,1	11,1	44,9	27,4	12,2	42,7	26,5	13,6	40,2	25,5	15,6
				33	50,0	34,6	9,6	48,6	34,1	10,3	47,0	33,4	11,1	45,1	32,5	12,2	42,9	31,5	13,6	40,5	30,3	15,7
Nominal airflow rate	8150 m <sup>3</sup> /h	16	21	42,8	25,9	9,6	41,6	25,4	10,2	40,2	24,7	11,0	38,5	23,9	12,1	36,5	22,9	13,5	34,3	21,8	15,7	
			24	43,0	32,3	9,6	41,8	31,6	10,2	40,4	30,8	11,1	38,7	29,8	12,1	36,8	28,7	13,6	34,6	27,3	15,7	
			27	43,3	37,9	9,6	42,2	37,2	10,3	40,8	36,3	11,1	39,2	35,2	12,2	37,2	33,9	13,7	35,1	32,3	15,8	
		19	24	46,6	25,5	9,8	45,2	24,9	10,5	43,6	24,3	11,3	41,7	23,6	12,4	39,6	22,7	13,9	37,2	21,7	16,0	
			27	46,6	32,0	9,8	45,3	31,4	10,5	43,8	30,7	11,3	41,9	29,7	12,4	39,8	28,7	13,9	37,4	27,4	16,1	
			30	46,9	37,8	9,9	45,7	37,1	10,5	44,1	36,3	11,4	42,3	35,2	12,5	40,2	34,0	13,9	37,9	32,5	16,1	
		22	27	50,7	24,3	10,1	49,2	23,9	10,8	47,5	23,3	11,6	45,4	22,7	12,7	43,1	22,0	14,2	40,6	21,2	16,4	
			30	50,7	31,2	10,1	49,3	30,6	10,8	47,5	30,0	11,6	45,5	29,2	12,7	43,3	28,2	14,2	40,7	27,1	16,4	
			33	51,0	37,2	10,1	49,5	36,5	10,8	47,8	35,8	11,7	45,8	34,9	12,8	43,6	33,7	14,3	41,1	32,4	16,5	
Maximum airflow rate	9050 m <sup>3</sup> /h	16	21	43,7	26,0	9,5	42,4	25,4	10,1	40,9	24,8	10,8	39,2	24,0	11,8	37,1	23,0	13,1	34,8	21,9	15,0	
			24	43,9	32,8	9,5	42,7	32,1	10,1	41,2	31,3	10,9	39,5	30,3	11,8	37,5	29,1	13,2	35,2	27,7	15,1	
			27	44,3	38,8	9,6	43,2	38,1	10,2	41,7	37,2	10,9	40,0	36,1	11,9	38,0	34,7	13,2	35,8	33,1	15,1	
		19	24	47,4	25,5	9,7	46,0	25,0	10,4	44,4	24,4	11,1	42,4	23,6	12,1	40,2	22,8	13,5	37,8	21,8	15,4	
			27	47,6	32,5	9,8	46,2	31,9	10,4	44,6	31,1	11,2	42,7	30,2	12,2	40,5	29,1	13,5	38,1	27,8	15,5	
			30	47,9	38,7	9,8	46,6	38,0	10,4	45,0	37,2	11,2	43,1	36,1	12,2	41,0	34,9	13,6	38,6	33,3	15,5	
		22	27	51,6	24,3	10,0	50,0	23,9	10,7	48,2	23,4	11,5	46,1	22,8	12,5	43,8	22,1	13,9	41,2	21,3	15,9	
			30	51,7	31,6	10,1	50,2	31,1	10,7	48,4	30,4	11,5	46,3	29,6	12,5	44,0	28,7	13,9	41,4	27,6	15,9	
			33	52,0	38,0	10,1	50,5	37,4	10,7	48,7	36,7	11,5	46,7	35,7	12,5	44,4	34,6	13,9	41,8	33,2	15,9	

**HEATING CAPACITIES**

Table 4.5b

CMH/CSH+CIH 040 S			Outdoor temperature (dry bulb)													
	Condenser air inlet temperature (dry bulb) °C		-10 °C		-5 °C		0 °C		5 °C		7 °C		10 °C		15 °C	
			GH	AC	GH	AC	GH	AC	GH	AC	GH	AC	GH	AC	GH	AC
Minimum airflow rate	6950 m <sup>3</sup> /h	15	27,37	6,96	31,63	7,78	35,81	8,56	39,92	9,32	41,55	9,62	43,97	10,07	47,95	10,84
		18	27,31	7,48	31,48	8,33	35,57	9,14	39,60	9,94	41,19	10,26	43,56	10,74	47,45	11,56
		20	27,27	7,84	31,38	8,71	35,41	9,54	39,38	10,37	40,95	10,70	43,28	11,21	47,11	12,07
		23	27,21	8,39	31,22	9,29	35,17	10,17	39,05	11,05	40,58	11,41	42,86	11,95	46,60	12,89
		25	27,16	8,77	31,12	9,70	35,00	10,61	38,82	11,53	40,33	11,90	42,57	12,47	46,26	13,47
Nominal airflow rate	8150 m <sup>3</sup> /h	15	28,09	7,05	32,44	7,80	36,72	8,51	40,93	9,20	42,60	9,47	45,08	9,89	49,16	10,58
		19	28,01	7,76	32,24	8,54	36,40	9,28	40,50	10,02	42,12	10,31	44,53	10,75	48,49	11,51
		20	27,99	7,94	32,19	8,73	36,32	9,48	40,39	10,23	42,00	10,53	44,39	10,98	48,32	11,76
		23	27,92	8,50	32,04	9,32	36,08	10,11	40,06	10,89	41,63	11,21	43,97	11,70	47,82	12,53
		25	27,88	8,89	31,93	9,72	35,92	10,54	39,84	11,35	41,39	11,69	43,69	12,19	47,48	13,07
Maximum airflow rate	9050 m <sup>3</sup> /h	15	28,36	6,91	32,79	7,61	37,14	8,28	41,43	8,92	43,13	9,18	45,66	9,56	49,81	10,20
		19	28,29	7,61	32,59	8,34	36,83	9,03	41,00	9,71	42,65	9,98	45,11	10,39	49,14	11,08
		20	28,27	7,79	32,54	8,52	36,75	9,22	40,90	9,91	42,53	10,19	44,97	10,61	48,98	11,32
		23	28,20	8,34	32,39	9,10	36,51	9,82	40,57	10,55	42,17	10,84	44,55	11,28	48,47	12,04
		25	28,16	8,72	32,29	9,49	36,35	10,24	40,35	10,99	41,93	11,29	44,27	11,75	48,13	12,55
27	28,11	9,10	32,19	9,89	36,19	10,66	40,12	11,44	41,68	11,75	43,99	12,24	47,79	13,08		

INDOOR FAN POWER INPUT (kW)			
Minimum airflow rate	1,12	Nominal airflow rate	1,42
Maximum airflow rate	1,67		

OUTDOOR FAN POWER INPUT (kW)	
Nominal airflow rate	2,05

<b>GC (kW)</b> :	Gross cooling capacity	<b>GH (kW)</b> :	Gross heating capacity	<b>SC (kW)</b> :	Sensible cooling capacity	<b>AC (kW)</b> :	Compressor absorbed power
------------------	------------------------	------------------	------------------------	------------------	---------------------------	------------------	---------------------------

**COOLING CAPACITIES**

Table 4.6a

CMC - CMH045 S			Outdoor temperature (dry bulb)																			
	Indoor wet bulb	Indoor dry bulb	20 °C			25 °C			30 °C			35 °C			40 °C			45 °C				
			GC	SC	AC	GC	SC	AC	GC	SC	AC	GC	SC	AC	GC	SC	AC	GC	SC	AC		
Minimum airflow rate	7950 m³/h	Evaporator air inlet temperature (°C)	16	21	48,4	27,9	9,7	47,1	27,2	10,4	45,6	26,5	11,3	43,7	25,6	12,4	41,5	24,6	13,9	39,1	23,5	16,1
				24	48,4	34,5	9,7	47,2	33,8	10,4	45,6	33,0	11,3	43,8	31,9	12,4	41,7	30,7	13,9	39,3	29,3	16,1
				27	48,7	40,2	9,7	47,5	39,5	10,4	46,0	38,6	11,3	44,2	37,5	12,5	42,1	36,1	14,0	39,7	34,5	16,1
			19	24	52,8	27,2	10,0	51,3	26,7	10,7	49,5	26,0	11,6	47,5	25,2	12,7	45,1	24,3	14,2	42,5	23,3	16,4
				27	52,7	34,2	9,9	51,2	33,5	10,7	49,5	32,7	11,6	47,5	31,8	12,7	45,2	30,6	14,3	42,6	29,4	16,4
				30	52,9	40,1	10,0	51,5	39,4	10,7	49,8	38,5	11,6	47,8	37,4	12,8	45,5	36,1	14,3	43,0	34,6	16,4
			22	27	57,6	25,8	10,3	55,9	25,3	11,0	54,0	24,7	12,0	51,8	24,1	13,1	49,3	23,3	14,7	46,4	22,5	16,8
				30	57,4	33,1	10,3	55,8	32,5	11,0	53,9	31,8	11,9	51,7	30,9	13,1	49,2	30,0	14,7	46,4	28,8	16,8
				33	57,5	39,2	10,3	55,9	38,5	11,0	54,0	37,8	12,0	51,9	36,8	13,1	49,4	35,7	14,7	46,7	34,3	16,9
Nominal airflow rate	9400 m³/h	Evaporator air inlet temperature (°C)	16	21	49,2	29,2	10,3	47,9	28,5	11,0	46,2	27,7	11,9	44,2	26,8	13,1	42,0	25,8	14,7	39,5	24,6	16,9
				24	49,4	36,4	10,3	48,0	35,6	11,0	46,4	34,7	12,0	44,5	33,6	13,1	42,3	32,3	14,7	39,8	30,8	16,9
				27	49,8	42,7	10,4	48,5	41,9	11,1	46,9	40,9	12,0	45,0	39,7	13,2	42,9	38,2	14,8	40,4	36,5	17,0
			19	24	53,6	28,7	10,6	52,0	28,0	11,3	50,2	27,3	12,2	48,0	26,5	13,4	45,6	25,6	15,0	42,9	24,5	17,3
				27	53,6	36,2	10,6	52,1	35,5	11,3	50,3	34,6	12,3	48,2	33,6	13,4	45,8	32,4	15,0	43,1	31,0	17,3
				30	54,0	42,7	10,6	52,5	41,9	11,4	50,7	40,9	12,3	48,6	39,8	13,5	46,3	38,4	15,1	43,6	36,8	17,4
			22	27	58,4	27,3	10,9	56,6	26,8	11,7	54,6	26,2	12,6	52,3	25,5	13,8	49,7	24,8	15,5	46,8	23,8	17,8
				30	58,3	35,2	10,9	56,6	34,6	11,7	54,7	33,8	12,6	52,4	32,9	13,9	49,8	31,9	15,5	47,0	30,7	17,8
				33	58,6	42,0	10,9	56,9	41,3	11,7	55,0	40,4	12,7	52,7	39,4	13,9	50,2	38,1	15,5	47,4	36,7	17,8
Maximum airflow rate	9750 m³/h	Evaporator air inlet temperature (°C)	16	21	49,5	29,2	10,3	48,1	28,6	11,1	46,4	27,8	11,9	44,5	26,9	13,1	42,2	25,9	14,6	39,6	24,6	16,8
				24	49,7	36,6	10,4	48,3	35,8	11,1	46,7	34,9	12,0	44,7	33,8	13,1	42,5	32,5	14,6	40,0	31,0	16,8
				27	50,2	43,0	10,4	48,8	42,2	11,1	47,2	41,2	12,0	45,3	40,0	13,2	43,1	38,5	14,7	40,6	36,8	16,9
			19	24	53,8	28,7	10,6	52,2	28,1	11,3	50,4	27,4	12,3	48,2	26,6	13,4	45,8	25,7	15,0	43,1	24,6	17,2
				27	53,9	36,4	10,6	52,4	35,7	11,4	50,5	34,8	12,3	48,4	33,8	13,4	46,0	32,6	15,0	43,3	31,2	17,2
				30	54,3	43,0	10,7	52,8	42,3	11,4	51,0	41,3	12,3	48,9	40,1	13,5	46,5	38,7	15,1	43,9	37,1	17,3
			22	27	58,6	27,4	11,0	56,9	26,9	11,7	54,8	26,3	12,7	52,5	25,6	13,9	49,9	24,9	15,5	47,0	23,9	17,7
				30	58,6	35,5	11,0	56,9	34,8	11,7	54,9	34,1	12,7	52,6	33,2	13,9	50,0	32,1	15,5	47,1	30,9	17,8
				33	58,9	42,4	11,0	57,2	41,7	11,7	55,2	40,8	12,7	53,0	39,8	13,9	50,4	38,5	15,5	47,6	37,0	17,8

**HEATING CAPACITIES**

Table 4.6b

CMH/CSH+CIH 045 S			Outdoor temperature (dry bulb)													
	Condenser air inlet temperature (dry bulb) °C		-10 °C		-5 °C		0 °C		5 °C		7 °C		10 °C		15 °C	
			GH	AC	GH	AC	GH	AC	GH	AC	GH	AC	GH	AC	GH	AC
Minimum airflow rate	7950 m³/h	15	31,98	7,76	37,01	8,74	41,93	9,69	46,74	10,64	48,63	11,03	51,43	11,62	56,00	12,65
		18	31,86	8,47	36,80	9,47	41,63	10,46	46,33	11,45	48,19	11,86	50,93	12,49	55,41	13,59
		20	31,79	8,97	36,67	9,99	41,43	11,01	46,07	12,04	47,90	12,47	50,60	13,13	55,02	14,29
		23	31,69	9,80	36,48	10,85	41,14	11,91	45,69	13,01	47,48	13,46	50,13	14,17	54,45	15,43
		25	31,64	10,39	36,36	11,47	40,96	12,57	45,45	13,71	47,21	14,19	49,82	14,93	54,07	16,27
		27	31,59	11,03	36,24	12,14	40,78	13,27	45,21	14,47	46,94	14,97	49,51	15,76	53,71	17,19
Nominal airflow rate	9400 m³/h	15	33,16	7,80	38,33	8,67	43,39	9,51	48,33	10,35	50,27	10,69	53,15	11,22	57,86	12,13
		19	32,97	8,73	38,02	9,62	42,95	10,49	47,76	11,39	49,65	11,75	52,46	12,32	57,04	13,30
		20	32,93	8,98	37,94	9,88	42,84	10,76	47,62	11,67	49,50	12,04	52,29	12,61	56,83	13,62
		23	32,81	9,78	37,73	10,69	42,53	11,61	47,21	12,56	49,06	12,95	51,78	13,57	56,24	14,66
		25	32,74	10,36	37,59	11,28	42,33	12,22	46,95	13,21	48,77	13,62	51,46	14,26	55,85	15,41
		27	32,67	10,98	37,46	11,91	42,13	12,88	46,69	13,90	48,48	14,33	51,13	15,00	55,46	16,22
Maximum airflow rate	9750 m³/h	15	33,35	7,76	38,55	8,60	43,64	9,42	48,61	10,24	50,57	10,57	53,47	11,08	58,21	11,96
		19	33,15	8,68	38,23	9,54	43,19	10,39	48,03	11,26	49,94	11,61	52,76	12,16	57,38	13,11
		20	33,11	8,93	38,15	9,80	43,08	10,65	47,89	11,53	49,79	11,89	52,59	12,45	57,17	13,42
		23	32,98	9,72	37,93	10,60	42,76	11,49	47,48	12,40	49,34	12,79	52,08	13,38	56,57	14,43
		25	32,90	10,29	37,79	11,18	42,56	12,09	47,21	13,04	49,04	13,43	51,75	14,05	56,17	15,16
		27	32,83	10,90	37,65	11,80	42,36	12,73	46,95	13,71	48,75	14,13	51,43	14,77	55,79	15,94

INDOOR FAN POWER INPUT (kW)			
Minimum airflow rate	1,70	Nominal airflow rate	2,18
Maximum airflow rate	2,30		
OUTDOOR FAN POWER INPUT (kW)			
Nominal airflow rate	3,15		

<b>GC (kW)</b> :	Gross cooling capacity	<b>GH (kW)</b> :	Gross heating capacity	<b>SC (kW)</b> :	Sensible cooling capacity	<b>AC (kW)</b> :	Compressor absorbed power
------------------	------------------------	------------------	------------------------	------------------	---------------------------	------------------	---------------------------



**COOLING CAPACITIES**

Table 4.7a

CMC - CMH055 D			Outdoor temperature (dry bulb)																			
	Indoor wet bulb	Indoor dry bulb	20 °C			25 °C			30 °C			35 °C			40 °C			45 °C				
			GC	SC	AC	GC	SC	AC	GC	SC	AC	GC	SC	AC	GC	SC	AC	GC	SC	AC		
Minimum airflow rate	9950 m <sup>3</sup> /h	Evaporator air inlet temperature (°C)	16	21	57,6	34,1	12,1	56,0	33,3	13,0	54,0	32,4	14,1	51,7	31,3	15,5	49,1	30,0	17,4	46,1	28,6	20,1
				24	57,8	42,3	12,1	56,2	41,4	13,0	54,3	40,3	14,2	52,1	39,1	15,6	49,4	37,5	17,5	46,5	35,8	20,2
				27	58,3	49,3	12,1	56,7	48,4	13,1	54,9	47,2	14,2	52,7	45,8	15,6	50,1	44,1	17,5	47,2	42,1	20,2
			19	24	62,7	33,3	12,4	60,9	32,5	13,3	58,8	31,7	14,5	56,3	30,7	15,9	53,4	29,6	17,8	50,2	28,3	20,5
				27	62,8	41,9	12,4	61,0	41,0	13,3	58,9	40,1	14,5	56,5	38,9	15,9	53,7	37,5	17,8	50,5	35,9	20,5
				30	63,2	49,1	12,4	61,5	48,2	13,4	59,4	47,2	14,5	57,0	45,8	15,9	54,3	44,3	17,9	51,2	42,4	20,5
			22	27	68,4	31,4	12,8	66,4	30,8	13,7	64,1	30,1	14,9	61,4	29,3	16,3	58,4	28,4	18,2	55,0	27,3	20,9
				30	68,4	40,4	12,8	66,4	39,7	13,7	64,2	38,9	14,9	61,5	37,8	16,3	58,5	36,7	18,2	55,2	35,3	20,9
				33	68,6	48,0	12,8	66,7	47,2	13,7	64,5	46,3	14,9	61,9	45,1	16,3	59,0	43,7	18,3	55,7	42,1	21,0
Nominal airflow rate	11700 m <sup>3</sup> /h	Evaporator air inlet temperature (°C)	16	21	58,9	35,7	12,4	57,3	34,9	13,3	55,2	34,0	14,4	52,8	32,8	15,8	50,1	31,5	17,8	47,0	30,0	20,5
				24	59,3	44,6	12,4	57,7	43,7	13,3	55,7	42,6	14,4	53,3	41,2	15,9	50,6	39,6	17,8	47,6	37,8	20,5
				27	60,0	52,3	12,4	58,4	51,4	13,4	56,5	50,1	14,5	54,2	48,6	16,0	51,5	46,8	17,9	48,5	44,7	20,6
			19	24	64,0	35,1	12,7	62,2	34,3	13,6	59,9	33,5	14,7	57,4	32,5	16,2	54,4	31,3	18,1	51,1	29,9	20,9
				27	64,3	44,4	12,7	62,5	43,5	13,6	60,3	42,5	14,8	57,8	41,2	16,2	54,9	39,7	18,2	51,6	38,0	20,9
				30	64,9	52,3	12,7	63,1	51,4	13,7	61,0	50,2	14,8	58,5	48,8	16,3	55,6	47,1	18,2	52,4	45,2	20,9
			22	27	69,7	33,4	13,0	67,6	32,8	14,0	65,2	32,1	15,1	62,5	31,2	16,6	59,4	30,3	18,6	55,9	29,1	21,3
				30	69,9	43,1	13,0	67,9	42,4	14,0	65,5	41,5	15,2	62,8	40,4	16,6	59,7	39,1	18,6	56,3	37,6	21,4
				33	70,3	51,4	13,1	68,4	50,6	14,0	66,0	49,6	15,2	63,4	48,3	16,7	60,3	46,8	18,7	56,9	45,1	21,4
Maximum airflow rate	12850 m <sup>3</sup> /h	Evaporator air inlet temperature (°C)	16	21	59,9	36,0	12,3	58,2	35,2	13,1	56,1	34,2	14,2	53,7	33,1	15,6	50,9	31,8	17,4	47,7	30,3	20,0
				24	60,4	45,3	12,3	58,7	44,4	13,2	56,7	43,3	14,3	54,3	41,9	15,7	51,5	40,3	17,5	48,4	38,4	20,1
				27	61,2	53,5	12,4	59,6	52,5	13,3	57,6	51,3	14,4	55,2	49,7	15,7	52,5	47,9	17,6	49,5	45,8	20,1
			19	24	65,0	35,4	12,6	63,1	34,6	13,5	60,8	33,8	14,6	58,2	32,8	16,0	55,2	31,6	17,8	51,8	30,3	20,5
				27	65,4	45,1	12,6	63,5	44,2	13,5	61,3	43,2	14,6	58,7	41,9	16,0	55,8	40,5	17,9	52,5	38,7	20,5
				30	66,1	53,5	12,7	64,3	52,6	13,6	62,1	51,4	14,7	59,5	50,0	16,1	56,6	48,3	18,0	53,4	46,3	20,6
			22	27	70,7	33,7	13,0	68,6	33,1	13,9	66,1	32,4	15,0	63,3	31,6	16,4	60,1	30,6	18,3	56,6	29,5	21,0
				30	71,0	43,9	13,0	68,9	43,2	13,9	66,5	42,3	15,0	63,7	41,2	16,5	60,6	39,9	18,4	57,1	38,4	21,0
				33	71,5	52,6	13,0	69,5	51,8	14,0	67,1	50,8	15,1	64,4	49,5	16,5	61,3	48,0	18,4	57,9	46,2	21,1

**HEATING CAPACITIES**

Table 4.7b

CMH/CSH+CIH 055 D			Outdoor temperature (dry bulb)													
	Condenser air inlet temperature (dry bulb) °C		-10 °C		-5 °C		0 °C		5 °C		7 °C		10 °C		15 °C	
			GH	AC	GH	AC	GH	AC	GH	AC	GH	AC	GH	AC	GH	AC
Minimum airflow rate	9950 m <sup>3</sup> /h	15	38,56	10,34	44,70	11,50	50,70	12,60	56,57	13,67	58,88	14,11	62,31	14,76	67,90	15,87
		18	38,41	11,23	44,40	12,41	50,26	13,54	55,98	14,66	58,23	15,11	61,56	15,80	67,01	16,98
		20	38,33	11,86	44,21	13,05	49,97	14,20	55,59	15,35	57,80	15,82	61,07	16,53	66,42	17,77
		23	38,20	12,86	43,94	14,07	49,55	15,26	55,02	16,47	57,17	16,96	60,35	17,72	65,55	19,04
		25	38,13	13,56	43,77	14,79	49,27	16,01	54,64	17,26	56,75	17,77	59,88	18,56	64,98	19,96
		27	38,06	14,30	43,60	15,54	49,01	16,79	54,27	18,09	56,34	18,62	59,41	19,45	64,41	20,93
Nominal airflow rate	11700 m <sup>3</sup> /h	15	39,15	9,95	45,48	11,02	51,67	12,03	57,72	13,01	60,11	13,40	63,64	13,99	69,43	14,99
		19	38,95	11,14	45,07	12,22	51,06	13,26	56,91	14,27	59,22	14,68	62,63	15,31	68,22	16,37
		20	38,90	11,46	44,97	12,54	50,91	13,58	56,72	14,61	59,00	15,02	62,39	15,66	67,92	16,74
		23	38,76	12,45	44,69	13,54	50,48	14,60	56,13	15,66	58,35	16,10	61,65	16,76	67,03	17,92
		25	38,68	13,14	44,50	14,24	50,19	15,31	55,75	16,41	57,93	16,86	61,16	17,55	66,45	18,75
		27	38,60	13,87	44,32	14,97	49,91	16,06	55,37	17,19	57,51	17,65	60,69	18,37	65,87	19,64
Maximum airflow rate	12850 m <sup>3</sup> /h	15	39,29	9,59	45,73	10,61	52,05	11,57	58,22	12,50	60,65	12,86	64,26	13,42	70,17	14,34
		19	39,07	10,76	45,31	11,79	51,42	12,76	57,40	13,72	59,75	14,10	63,24	14,68	68,95	15,66
		20	39,02	11,08	45,21	12,10	51,27	13,08	57,20	14,04	59,53	14,43	62,99	15,01	68,64	16,02
		23	38,87	12,05	44,92	13,07	50,83	14,06	56,60	15,05	58,87	15,46	62,24	16,07	67,75	17,13
		25	38,78	12,74	44,72	13,76	50,54	14,76	56,21	15,77	58,44	16,18	61,75	16,82	67,16	17,92
		27	38,69	13,46	44,54	14,48	50,25	15,49	55,83	16,52	58,02	16,95	61,27	17,60	66,57	18,76

<b>INDOOR FAN POWER INPUT (kW)</b>			
Minimum airflow rate	1,45	Nominal airflow rate	1,76
Maximum airflow rate	2,00		
<b>OUTDOOR FAN POWER INPUT (kW)</b>			
Nominal airflow rate	3,56		

<b>GC (kW)</b> :	Gross cooling capacity	<b>GH (kW)</b> :	Gross heating capacity	<b>SC (kW)</b> :	Sensible cooling capacity	<b>AC (kW)</b> :	Compressor absorbed power
------------------	------------------------	------------------	------------------------	------------------	---------------------------	------------------	---------------------------

**COOLING CAPACITIES**

Table 4.8a

CMC - CMH070 D			Outdoor temperature (dry bulb)																		
	Indoor wet bulb	Indoor dry bulb	20 °C			25 °C			30 °C			35 °C			40 °C			45 °C			
			GC	SC	AC	GC	SC	AC	GC	SC	AC	GC	SC	AC	GC	SC	AC	GC	SC	AC	
Minimum airflow rate 12450 m³/h	Evaporator air inlet temperature (°C)	16	21	71,6	41,9	16,0	69,8	40,9	17,2	67,6	39,8	18,6	64,9	38,5	20,4	61,8	37,1	22,8	58,2	35,4	26,2
			24	72,0	51,6	16,1	70,2	50,6	17,2	68,0	49,4	18,6	65,4	47,9	20,4	62,3	46,2	22,8	58,8	44,2	26,3
			27	72,5	60,8	16,1	70,7	59,8	17,3	68,5	58,5	18,7	65,9	56,9	20,5	62,8	55,0	22,9	59,3	52,6	26,4
		19	24	77,8	41,1	16,5	75,8	40,1	17,6	73,3	39,1	19,0	70,4	37,9	20,9	67,0	36,5	23,3	63,2	34,9	26,8
			27	78,2	50,8	16,5	76,2	49,9	17,7	73,7	48,7	19,1	70,8	47,3	20,9	67,5	45,7	23,4	63,8	43,8	26,9
			30	78,7	60,0	16,6	76,6	59,1	17,7	74,2	57,8	19,1	71,3	56,3	21,0	68,0	54,5	23,4	64,3	52,4	26,9
		22	27	84,6	39,8	17,0	82,3	38,9	18,1	79,6	37,9	19,6	76,4	36,8	21,4	72,9	35,6	23,9	68,8	34,2	27,4
			30	85,0	49,6	17,0	82,8	48,7	18,2	80,0	47,6	19,6	76,9	46,3	21,4	73,3	44,9	23,9	69,4	43,2	27,4
			33	85,4	58,8	17,0	83,2	57,9	18,2	80,5	56,7	19,6	77,4	55,4	21,5	73,9	53,7	24,0	69,9	51,8	27,5
Nominal airflow rate 14650 m³/h	Evaporator air inlet temperature (°C)	16	21	73,4	43,4	16,3	71,5	42,4	17,4	69,1	41,4	18,7	66,3	40,1	20,5	63,0	38,6	22,8	59,4	36,8	26,1
			24	73,9	54,4	16,4	71,9	53,4	17,5	69,6	52,2	18,8	66,8	50,7	20,5	63,6	48,9	22,8	59,9	46,7	26,2
			27	74,3	65,0	16,4	72,4	64,0	17,5	70,1	62,6	18,9	67,3	60,9	20,6	64,1	58,8	22,9	60,5	56,3	26,3
		19	24	79,8	42,3	16,8	77,6	41,4	17,9	74,9	40,4	19,3	71,9	39,2	21,0	68,4	37,9	23,4	64,5	36,3	26,8
			27	80,2	53,5	16,8	78,0	52,6	17,9	75,4	51,4	19,3	72,4	50,0	21,1	68,9	48,3	23,5	65,0	46,4	26,8
			30	80,6	64,3	16,9	78,5	63,2	18,0	75,9	62,0	19,4	72,9	60,4	21,1	69,5	58,4	23,5	65,6	56,1	26,9
		22	27	86,7	40,7	17,3	84,3	39,9	18,4	81,4	39,0	19,8	78,1	37,9	21,6	74,4	36,7	24,0	70,3	35,4	27,5
			30	87,1	52,1	17,3	84,7	51,2	18,4	81,9	50,1	19,9	78,6	48,9	21,7	74,9	47,4	24,1	70,8	45,7	27,5
			33	87,5	62,9	17,3	85,1	62,0	18,5	82,3	60,8	19,9	79,1	59,4	21,7	75,4	57,6	24,1	71,3	55,6	27,6
Maximum airflow rate 15090 m³/h	Evaporator air inlet temperature (°C)	16	21	74,1	43,4	16,0	72,1	42,5	17,0	69,7	41,4	18,3	66,9	40,1	19,9	63,6	38,7	22,0	59,9	36,9	25,1
			24	74,5	54,7	16,1	72,6	53,8	17,1	70,2	52,5	18,3	67,4	51,0	20,0	64,1	49,2	22,1	60,5	47,1	25,2
			27	75,0	65,7	16,1	73,1	64,6	17,1	70,7	63,3	18,4	67,9	61,6	20,0	64,7	59,5	22,2	61,0	56,9	25,3
		19	24	80,5	42,2	16,5	78,2	41,3	17,5	75,6	40,3	18,8	72,5	39,2	20,5	69,0	37,9	22,7	65,1	36,3	25,8
			27	80,9	53,8	16,5	78,7	52,8	17,6	76,1	51,7	18,9	73,0	50,3	20,5	69,5	48,6	22,8	65,6	46,7	25,9
			30	81,3	64,8	16,6	79,1	63,8	17,6	76,5	62,6	18,9	73,5	61,0	20,6	70,1	59,0	22,8	66,2	56,7	26,0
		22	27	87,4	40,5	17,0	85,0	39,7	18,1	82,1	38,8	19,4	78,8	37,8	21,1	75,0	36,6	23,4	70,9	35,3	26,6
			30	87,8	52,2	17,0	85,4	51,3	18,1	82,5	50,3	19,5	79,3	49,1	21,2	75,5	47,6	23,4	71,4	45,9	26,6
			33	88,3	63,3	17,1	85,9	62,4	18,2	83,0	61,3	19,5	79,7	59,9	21,2	76,1	58,1	23,5	71,9	56,0	26,7

**HEATING CAPACITIES**

Table 4.8b

CMH/CSH+CIH 070 D			Outdoor temperature (dry bulb)													
	Condenser air inlet temperature (dry bulb) °C		-10 °C		-5 °C		0 °C		5 °C		7 °C		10 °C		15 °C	
			GH	AC	GH	AC	GH	AC	GH	AC	GH	AC	GH	AC	GH	AC
Minimum airflow rate 12450 m³/h		15	45,12	12,11	52,17	13,52	59,10	14,86	65,93	16,17	68,64	16,69	72,66	17,47	79,29	18,79
		18	45,04	13,00	51,94	14,46	58,73	15,86	65,42	17,23	68,07	17,78	72,01	18,62	78,49	20,03
		20	44,98	13,62	51,78	15,11	58,48	16,55	65,08	17,98	67,69	18,55	71,57	19,42	77,96	20,91
		23	44,88	14,56	51,54	16,12	58,10	17,64	64,56	19,15	67,11	19,77	70,91	20,70	77,15	22,32
		25	44,81	15,22	51,38	16,82	57,85	18,39	64,21	19,98	66,72	20,62	70,46	21,61	76,61	23,32
27	44,75	15,88	51,22	17,53	57,59	19,17	63,85	20,83	66,33	21,51	70,02	22,55	76,07	24,37		
Nominal airflow rate 14650 m³/h		15	46,36	12,15	53,57	13,42	60,68	14,63	67,68	15,80	70,45	16,26	74,58	16,96	81,37	18,14
		19	46,24	13,39	53,26	14,71	60,18	15,98	67,00	17,22	69,69	17,72	73,70	18,47	80,31	19,75
		20	46,21	13,71	53,19	15,05	60,06	16,33	66,82	17,59	69,50	18,10	73,48	18,87	80,04	20,18
		23	46,11	14,70	52,95	16,08	59,68	17,42	66,30	18,76	68,92	19,30	72,82	20,12	79,24	21,53
		25	46,05	15,38	52,79	16,79	59,42	18,18	65,95	19,57	68,53	20,13	72,37	21,00	78,70	22,49
27	45,98	16,07	52,62	17,53	59,16	18,96	65,60	20,41	68,14	21,00	71,93	21,91	78,15	23,49		
Maximum airflow rate 15090 m³/h		15	46,37	11,97	53,62	13,22	60,76	14,41	67,80	15,56	70,58	16,01	74,73	16,70	81,56	17,85
		19	46,26	13,20	53,31	14,50	60,26	15,74	67,11	16,96	69,82	17,45	73,85	18,18	80,49	19,43
		20	46,23	13,52	53,23	14,83	60,14	16,09	66,94	17,33	69,63	17,82	73,63	18,58	80,23	19,86
		23	46,13	14,51	53,00	15,86	59,76	17,17	66,42	18,47	69,05	19,00	72,97	19,80	79,42	21,18
		25	46,06	15,18	52,83	16,56	59,50	17,92	66,07	19,27	68,66	19,82	72,53	20,66	78,88	22,11
27	45,99	15,87	52,67	17,29	59,24	18,69	65,71	20,10	68,27	20,68	72,08	21,56	78,34	23,10		

INDOOR FAN POWER INPUT (kW)			
Minimum airflow rate	2,32	Nominal airflow rate	2,88
Maximum airflow rate	3		
OUTDOOR FAN POWER INPUT (kW)			
Nominal airflow rate	3,84		

<b>GC (kW)</b> :	Gross cooling capacity	<b>GH (kW)</b> :	Gross heating capacity	<b>SC (kW)</b> :	Sensible cooling capacity	<b>AC (kW)</b> :	Compressor absorbed power
------------------	------------------------	------------------	------------------------	------------------	---------------------------	------------------	---------------------------

**COOLING CAPACITIES**

Table 4.9a

CMC - CMH085 D			Outdoor temperature (dry bulb)																			
	Indoor wet bulb	Indoor dry bulb	20 °C			25 °C			30 °C			35 °C			40 °C			45 °C				
			GC	SC	AC	GC	SC	AC	GC	SC	AC	GC	SC	AC	GC	SC	AC	GC	SC	AC		
Minimum airflow rate	14000 m³/h	Evaporator air inlet temperature (°C)	16	21	86,8	50,5	18,2	84,6	49,4	19,5	81,8	48,1	21,1	78,5	46,6	23,2	74,7	44,8	26,1	70,3	42,7	30,3
				24	87,0	63,1	18,2	84,9	61,9	19,5	82,2	60,4	21,1	78,9	58,5	23,2	75,1	56,3	26,2	70,8	53,7	30,4
				27	87,8	73,7	18,2	85,7	72,4	19,6	83,1	70,7	21,2	79,9	68,7	23,4	76,2	66,2	26,3	71,9	63,2	30,5
			19	24	94,4	49,3	18,7	91,9	48,3	20,0	88,8	47,1	21,6	85,2	45,7	23,8	81,0	44,1	26,7	76,3	42,2	30,9
				27	94,5	62,5	18,7	92,0	61,4	20,0	89,0	59,9	21,6	85,4	58,2	23,8	81,3	56,1	26,7	76,7	53,7	31,0
				30	95,1	73,4	18,7	92,7	72,1	20,0	89,7	70,6	21,7	86,2	68,6	23,9	82,2	66,3	26,8	77,6	63,5	31,1
			22	27	103,0	46,4	19,3	100,1	45,6	20,6	96,7	44,6	22,3	92,8	43,5	24,4	88,3	42,2	27,4	83,3	40,6	31,7
				30	102,8	60,4	19,3	100,1	59,3	20,6	96,7	58,1	22,3	92,9	56,6	24,5	88,4	54,8	27,5	83,5	52,7	31,8
				33	103,3	71,8	19,3	100,5	70,6	20,6	97,3	69,2	22,3	93,5	67,5	24,5	89,1	65,4	27,5	84,2	62,9	31,9
Nominal airflow rate	16250 m³/h	Evaporator air inlet temperature (°C)	16	21	88,5	52,4	18,7	86,2	51,3	20,0	83,3	49,9	21,6	79,8	48,3	23,7	75,9	46,5	26,5	71,3	44,3	30,8
				24	89,1	66,0	18,7	86,8	64,7	20,0	83,9	63,1	21,6	80,6	61,1	23,7	76,6	58,8	26,6	72,2	56,0	30,9
				27	90,1	77,5	18,8	87,9	76,2	20,1	85,1	74,4	21,8	81,8	72,2	23,9	77,9	69,6	26,8	73,5	66,5	31,0
			19	24	96,1	51,4	19,2	93,4	50,3	20,5	90,2	49,1	22,1	86,5	47,7	24,3	82,2	46,0	27,2	77,3	44,0	31,5
				27	96,5	65,6	19,2	93,8	64,4	20,5	90,7	62,9	22,2	87,0	61,0	24,3	82,8	58,9	27,3	78,0	56,3	31,6
				30	97,4	77,5	19,3	94,8	76,2	20,6	91,7	74,5	22,3	88,1	72,4	24,5	83,9	69,9	27,4	79,2	67,0	31,7
			22	27	104,6	48,8	19,8	101,6	47,9	21,2	98,1	46,9	22,8	94,0	45,7	25,0	89,4	44,3	28,0	84,2	42,7	32,4
				30	104,8	63,7	19,8	101,9	62,6	21,2	98,4	61,3	22,9	94,4	59,7	25,1	89,8	57,8	28,1	84,7	55,6	32,5
				33	105,5	76,2	19,9	102,6	74,9	21,2	99,2	73,4	23,0	95,3	71,6	25,2	90,8	69,3	28,2	85,8	66,7	32,6
Maximum airflow rate	16725 m³/h	Evaporator air inlet temperature (°C)	16	21	89,3	52,6	18,4	86,9	51,5	19,7	83,9	50,2	21,2	80,5	48,6	23,2	76,5	46,7	25,9	71,9	44,5	29,8
				24	89,8	66,5	18,5	87,5	65,2	19,7	84,6	63,6	21,3	81,2	61,6	23,2	77,3	59,3	26,0	72,8	56,5	29,9
				27	91,0	78,3	18,6	88,7	76,9	19,8	85,9	75,2	21,4	82,6	73,0	23,4	78,7	70,3	26,1	74,2	67,2	30,0
			19	24	96,8	51,6	19,0	94,1	50,6	20,2	90,9	49,4	21,8	87,1	48,0	23,8	82,7	46,3	26,6	77,9	44,3	30,6
				27	97,2	66,1	19,0	94,6	64,9	20,3	91,4	63,4	21,8	87,7	61,5	23,9	83,4	59,4	26,7	78,6	56,8	30,7
				30	98,2	78,3	19,1	95,6	76,9	20,4	92,5	75,3	21,9	88,8	73,2	24,0	84,6	70,7	26,8	79,9	67,7	30,8
			22	27	105,3	49,0	19,6	102,3	48,2	20,9	98,7	47,2	22,5	94,6	46,0	24,6	90,0	44,6	27,5	84,8	43,0	31,6
				30	105,5	64,2	19,6	102,6	63,1	20,9	99,1	61,8	22,5	95,1	60,2	24,7	90,5	58,3	27,5	85,3	56,1	31,7
				33	106,3	76,9	19,7	103,4	75,7	21,0	100,0	74,2	22,6	96,0	72,3	24,7	91,5	70,1	27,6	86,4	67,4	31,8

**HEATING CAPACITIES**

Table 4.9b

CMH/CSH+CIH 085 D			Outdoor temperature (dry bulb)													
	Condenser air inlet temperature (dry bulb) °C		-10 °C		-5 °C		0 °C		5 °C		7 °C		10 °C		15 °C	
			GH	AC	GH	AC	GH	AC	GH	AC	GH	AC	GH	AC	GH	AC
Minimum airflow rate	14000 m³/h	15	52,67	13,52	60,81	15,06	68,87	16,54	76,87	17,98	80,05	18,56	84,80	19,42	92,66	20,89
		18	52,61	14,55	60,59	16,15	68,50	17,70	76,35	19,22	79,47	19,83	84,12	20,75	91,83	22,33
		20	52,57	15,26	60,45	16,91	68,26	18,50	76,00	20,08	79,07	20,72	83,67	21,69	91,27	23,34
		23	52,50	16,36	60,22	18,08	67,88	19,76	75,46	21,45	78,48	22,13	82,98	23,17	90,43	24,97
		25	52,45	17,11	60,07	18,88	67,62	20,63	75,10	22,40	78,08	23,12	82,52	24,22	89,86	26,13
		27	52,39	17,87	59,91	19,71	67,36	21,54	74,74	23,39	77,67	24,15	82,05	25,31	89,30	27,34
Nominal airflow rate	16250 m³/h	15	54,01	13,53	62,32	14,93	70,55	16,27	78,72	17,57	81,97	18,09	86,82	18,87	94,85	20,19
		19	53,94	14,96	62,04	16,42	70,07	17,83	78,03	19,22	81,19	19,78	85,92	20,62	93,74	22,07
		20	53,92	15,33	61,97	16,81	69,95	18,23	77,86	19,65	81,00	20,22	85,70	21,09	93,47	22,56
		23	53,85	16,47	61,75	18,00	69,57	19,49	77,33	21,00	80,41	21,60	85,01	22,53	92,63	24,13
		25	53,81	17,24	61,60	18,82	69,32	20,37	76,97	21,93	80,01	22,57	84,55	23,55	92,07	25,23
		27	53,76	18,03	61,44	19,65	69,06	21,27	76,61	22,91	79,61	23,58	84,09	24,61	91,50	26,39
Maximum airflow rate	16725 m³/h	15	54,12	13,40	62,46	14,78	70,74	16,09	78,94	17,36	82,20	17,87	87,07	18,64	95,14	19,93
		19	54,05	14,83	62,19	16,26	70,25	17,64	78,25	19,00	81,43	19,55	86,18	20,37	94,03	21,78
		20	54,03	15,20	62,12	16,65	70,13	18,04	78,08	19,43	81,23	19,98	85,95	20,83	93,76	22,27
		23	53,97	16,33	61,90	17,83	69,76	19,29	77,55	20,76	80,64	21,35	85,27	22,26	92,92	23,81
		25	53,92	17,10	61,75	18,64	69,50	20,16	77,19	21,69	80,25	22,31	84,81	23,26	92,36	24,90
		27	53,87	17,89	61,59	19,48	69,25	21,05	76,83	22,65	79,85	23,30	84,35	24,30	91,80	26,04

INDOOR FAN POWER INPUT (kW)			
Minimum airflow rate	3,28	Nominal airflow rate	4
Maximum airflow rate	4,16		
OUTDOOR FAN POWER INPUT (kW)			
Nominal airflow rate	4,20		

<b>GC (kW) :</b>	Gross cooling capacity	<b>GH (kW) :</b>	Gross heating capacity	<b>SC (kW) :</b>	Sensible cooling capacity	<b>AC (kW) :</b>	Compressor absorbed power
------------------	------------------------	------------------	------------------------	------------------	---------------------------	------------------	---------------------------

**COOLING CAPACITIES**

Table 4.10a

CMC - CMH0100 D			Outdoor temperature (dry bulb)																			
		Evaporator air inlet temperature (°C)	Indoor wet bulb	Indoor dry bulb	20 °C			25 °C			30 °C			35 °C			40 °C			45 °C		
					GC	SC	AC	GC	SC	AC	GC	SC	AC	GC	SC	AC	GC	SC	AC	GC	SC	AC
					GC	SC	AC	GC	SC	AC	GC	SC	AC	GC	SC	AC	GC	SC	AC	GC	SC	AC
Minimum airflow rate	17350 m³/h	16	21	103,7	60,6	23,5	101,0	59,3	25,2	97,6	57,7	27,3	93,6	55,9	30,1	88,9	53,7	33,9	83,6	51,2	39,5	
			24	104,1	74,5	23,5	101,4	73,2	25,2	98,1	71,5	27,4	94,1	69,4	30,1	89,4	67,0	33,9	84,1	64,0	39,5	
			27	104,3	88,1	23,5	101,6	86,9	25,2	98,3	85,1	27,4	94,3	82,9	30,1	89,6	80,1	34,0	84,3	76,7	39,6	
			19	24	112,8	59,4	24,1	109,7	58,0	25,8	106,0	56,5	28,0	101,7	54,7	30,8	96,6	52,7	34,6	91,0	50,4	40,3
				27	113,3	73,2	24,2	110,3	71,9	25,9	106,6	70,3	28,1	102,2	68,3	30,9	97,2	66,0	34,7	91,6	63,3	40,4
				30	113,6	86,8	24,2	110,6	85,5	25,9	106,9	83,9	28,1	102,5	81,8	30,9	97,5	79,2	34,8	91,9	76,0	40,4
			22	27	122,4	58,0	24,8	119,0	56,6	26,6	115,0	55,0	28,8	110,3	53,4	31,7	104,9	51,5	35,6	98,9	49,4	41,4
				30	123,1	71,5	24,9	119,7	70,2	26,7	115,6	68,6	28,9	110,9	66,8	31,8	105,6	64,7	35,7	99,6	62,2	41,5
				33	123,4	84,9	24,9	120,0	83,7	26,7	116,0	82,1	28,9	111,3	80,2	31,8	106,0	77,8	35,8	100,0	75,0	41,6
Nominal airflow rate	20400 m³/h	16	21	106,7	62,8	23,5	103,8	61,4	25,2	100,2	59,9	27,2	96,0	58,0	29,8	91,1	55,8	33,4	85,6	53,3	38,8	
			24	107,2	78,5	23,6	104,3	77,1	25,2	100,8	75,4	27,2	96,6	73,3	29,9	91,7	70,6	33,5	86,2	67,5	38,8	
			27	107,5	94,1	23,6	104,6	92,7	25,2	101,1	90,8	27,3	96,9	88,4	29,9	92,0	85,3	33,5	86,5	81,6	38,8	
		19	24	115,9	61,3	24,2	112,7	59,9	25,9	108,8	58,4	28,0	104,2	56,6	30,7	99,0	54,6	34,4	93,1	52,3	39,8	
			27	116,6	77,1	24,3	113,3	75,7	25,9	109,4	74,0	28,0	104,9	72,0	30,8	99,7	69,6	34,5	93,8	66,7	39,9	
			30	116,9	92,7	24,3	113,7	91,3	26,0	109,8	89,5	28,1	105,3	87,3	30,8	100,1	84,5	34,5	94,2	81,1	39,9	
		22	27	125,7	59,5	25,0	122,1	58,1	26,7	117,9	56,7	28,9	113,0	55,0	31,7	107,4	53,2	35,5	101,2	51,1	41,1	
			30	126,4	75,1	25,0	122,9	73,8	26,8	118,6	72,2	28,9	113,7	70,4	31,8	108,2	68,2	35,6	101,9	65,6	41,2	
			33	126,9	90,7	25,1	123,3	89,4	26,8	119,1	87,7	29,0	114,2	85,7	31,8	108,7	83,2	35,7	102,5	80,1	41,2	
Maximum airflow rate	22450 m³/h	16	21	110,0	62,4	22,0	107,0	61,2	23,4	103,3	59,7	25,1	98,9	57,9	27,2	93,9	55,8	30,1	88,3	53,4	34,2	
			24	110,6	79,6	22,1	107,6	78,3	23,4	103,9	76,6	25,1	99,6	74,5	27,3	94,6	72,0	30,2	88,9	68,9	34,3	
			27	111,0	96,7	22,1	107,9	95,3	23,5	104,3	93,5	25,2	100,0	91,0	27,3	95,0	88,0	30,2	89,3	84,3	34,3	
		19	24	119,4	60,4	22,8	116,0	59,1	24,2	112,0	57,7	26,0	107,3	56,1	28,2	101,9	54,2	31,2	95,9	52,0	35,5	
			27	120,1	77,7	22,8	116,7	76,4	24,3	112,7	74,8	26,0	108,0	72,9	28,3	102,7	70,6	31,3	96,7	67,8	35,6	
			30	120,5	94,9	22,9	117,1	93,6	24,3	113,1	91,8	26,1	108,5	89,6	28,3	103,1	86,8	31,4	97,1	83,5	35,6	
		22	27	129,2	58,0	23,6	125,5	56,8	25,1	121,1	55,5	27,0	116,1	54,0	29,4	110,4	52,3	32,5	104,0	50,4	37,0	
			30	130,0	75,3	23,7	126,3	74,0	25,2	122,0	72,6	27,1	116,9	70,8	29,4	111,2	68,8	32,6	104,9	66,3	37,1	
			33	130,5	92,1	23,7	126,8	90,8	25,2	122,5	89,3	27,1	117,5	87,3	29,5	111,8	84,8	32,7	105,4	81,8	37,2	

**HEATING CAPACITIES**

Table 4.10b

CSH+CIH 100 D			Outdoor temperature (dry bulb)													
		Condenser air inlet temperature (dry bulb) °C	-10 °C		-5 °C		0 °C		5 °C		7 °C		10 °C		15 °C	
			GH	AC	GH	AC	GH	AC	GH	AC	GH	AC	GH	AC	GH	AC
Minimum airflow rate	17350 m³/h	15	65,59	17,56	75,90	19,47	86,10	21,30	96,19	23,10	100,19	23,81	106,17	24,90	116,04	26,75
		18	65,50	18,92	75,61	20,89	85,61	22,79	95,50	24,68	99,43	25,44	105,29	26,59	114,96	28,57
		20	65,44	19,86	75,42	21,87	85,29	23,83	95,05	25,79	98,93	26,58	104,71	27,79	114,25	29,86
		23	65,37	21,34	75,15	23,42	84,82	25,48	94,39	27,55	98,18	28,40	103,84	29,69	113,19	31,94
		25	65,33	22,35	74,98	24,50	84,52	26,63	93,95	28,79	97,69	29,68	103,27	31,04	112,48	33,42
		27	65,29	23,40	74,81	25,61	84,21	27,82	93,51	30,09	97,20	31,02	102,70	32,46	111,78	34,98
Nominal airflow rate	20400 m³/h	15	66,95	17,42	77,48	19,15	87,89	20,80	98,19	22,42	102,28	23,07	108,38	24,05	118,47	25,70
		19	66,82	19,31	77,08	21,09	87,23	22,81	97,27	24,53	101,25	25,22	107,20	26,27	117,02	28,07
		20	66,79	19,80	76,99	21,60	87,07	23,34	97,04	25,08	101,00	25,79	106,90	26,86	116,66	28,71
		23	66,71	21,33	76,70	23,17	86,59	24,99	96,36	26,82	100,24	27,57	106,03	28,72	115,59	30,70
		25	66,66	22,38	76,52	24,27	86,27	26,14	95,92	28,05	99,74	28,83	105,45	30,03	114,88	32,12
		27	66,61	23,46	76,34	25,40	85,96	27,33	95,48	29,32	99,25	30,14	104,88	31,40	114,17	33,61
Maximum airflow rate	22450 m³/h	15	66,62	16,20	77,28	17,86	87,84	19,43	98,28	20,97	102,43	21,58	108,62	22,50	118,84	24,05
		19	66,48	18,00	76,88	19,70	87,17	21,34	97,35	22,95	101,39	23,60	107,42	24,58	117,39	26,25
		20	66,45	18,47	76,78	20,18	87,01	21,83	97,12	23,47	101,14	24,13	107,13	25,13	117,03	26,84
		23	66,36	19,93	76,49	21,68	86,52	23,39	96,44	25,10	100,38	25,80	106,25	26,86	115,95	28,68
		25	66,30	20,94	76,31	22,72	86,20	24,47	95,99	26,24	99,87	26,97	105,66	28,07	115,23	29,99
		27	66,25	21,97	76,12	23,79	85,89	25,59	95,54	27,43	99,37	28,18	105,09	29,34	114,52	31,36

INDOOR FAN POWER INPUT (kW)			
Minimum airflow rate	3,13	Nominal airflow rate	3,89
		Maximum airflow rate	4,45

OUTDOOR FAN POWER INPUT (kW)	
Nominal airflow rate	5,76

<b>GC (kW)</b> :	Gross cooling capacity	<b>GH (kW)</b> :	Gross heating capacity	<b>SC (kW)</b> :	Sensible cooling capacity	<b>AC (kW)</b> :	Compressor absorbed power
------------------	------------------------	------------------	------------------------	------------------	---------------------------	------------------	---------------------------

**HOT WATER COIL - AIR TREATMENT UNIT**

Table 4.11

CIC/CIH	Temperature difference between water inlet and air inlet			Water flow rate	Water coil pressure drop	Air pressure drop Pa		Nr of rows	Weight	Water outlet diameter
	50 °C	60 °C	70 °C			Nominal air flow rate	Minimum air flow rate			
	CAPACITY W			L/H	kPa			Kg		
20 S	24	29	34	2100	36	20	15	2	10	3/4"
25 S	29	35	41	2500	54	32	25	2	10	3/4"
30 S	30	37	43	2600	57	37	25	2	10	3/4"
35 S	42	51	60	3700	40	32	25	2	12	1"
40 S	46	56	65	4000	47	40	31	2	16	1"
45 D	50	60	71	4400	56	50	38	2	20	1"
55 D	69	83	98	6000	30	31	24	2	20	1 1/4"
70 D	79	96	112	6900	39	44	34	2	24	1 1/4"
85 D	86	104	122	7500	46	53	41	2	30	1 1/4"
100 D	129	156	183	11300	42	30	23	2	40	1 1/2"

**ELECTRICAL COIL SELECTION - AIR TREATMENT UNIT**

Table 4.12

			CIC/CIH										
			20 S	25 S	30 S	35 S	40 S	45 D	55 D	70 D	85 D	100 D	
<b>STANDARD</b>	Capacity	kW	10	10	10	15	15	15	20	20	20	30	
	Nr of stages		1	1	1	2	2	2	2	2	2	2	
	Temperature rise	°C	8,2	6,1	5,6	6,4	5,6	4,8	5,2	4,1	3,7	4,5	
<b>MEDIUM</b>	Capacity	kW	15	15	15	20	20	20	27	27	27	40	
	Nr of stages		2	2	2	2	2	2	2	2	2	2	
	Temperature rise	°C	12,3	9,1	8,3	8,5	7,4	6,4	7	5,6	5	5,9	
<b>HIGH HEAT 2 STEPS</b>	Capacity	kW	20	20	20	27	27	27	40	40	40	50	
	Nr of stages		2	2	2	2	2	2	2	2	2	1	
	Temperature rise	°C	16,4	12,1	11,1	11,5	10	8,7	10,4	8,3	7,5	7,4	
<b>HIGH HEAT MODULATING</b>	Capacity	kW	20	20	20	27	27	27	40	40	40	50	
	Nr of stages		NA										
	Temperature rise	°C	16,4	12,1	11,1	11,5	10	8,7	10,4	8,3	7,5	7,4	

na : Non applicable



**INDOOR NOISE LEVEL - AIR TREATMENT SECTION - IN DUCT**
**STANDARD**
**Spectrum per octave band (dB(A))**

CIC/CIH	125	250	500	1000	2000	4000	8000	Total sound power
								Lw dB(A)
20 S	76,6	69,8	69,1	70	67,5	62,9	54,6	74,2
25 S	87,0	83,0	76,7	76,3	76,3	73,5	66,8	82,9
30 S	86,5	82,8	77,3	77,0	77,0	74,1	67,6	83,4
35 S	86,8	82,8	82	78,3	78,3	76,4	70,8	85,3
40 S	85,7	82	81,8	78,2	78,2	76,4	71,3	85,1
45 D	89,1	84,9	85,9	81,5	81,2	80,1	75,6	88,6
55 D	79,1	79,1	75,4	74,4	74,1	70,6	64,4	80,3
70 D	89,9	85	85,5	80,7	80,6	79,3	74,2	88,0
85 D	96,7	90,7	88,2	86	85,5	84,5	80,6	92,8
100 D	84,3	82,8	81,4	79,0	79,0	75,8	68,4	85,3

**OUTDOOR NOISE LEVEL - THERMODYNAMIC SECTION - IN DUCT**
**STANDARD UNIT**
**Spectrum per octave band (dB(A))**

CSC/CSH CMC/CMH	125	250	500	1000	2000	4000	8000	Total sound power
								Lw dB(A)
20 S	75,6	77,7	75,4	74,4	73,4	71,5	65,9	80
25 S	78,6	79,4	78,2	76,4	76,1	74,0	69,1	83
30 S	81,4	81,5	81,9	79,5	79,6	77,5	73,3	86
35 S	79,4	80,5	80,2	77,4	77,5	75,2	68,1	84
40 S	79,2	80,2	79,8	77,4	77,6	74,7	67,9	84
45 D	81,7	83,1	83,5	80,5	80,9	80,6	72,8	88
55 D	85,6	81,3	83,4	80,1	81,5	78,8	72,9	87
70 D	85,5	81,9	84,2	81,1	81,6	79,2	73,1	88
85 D	85,8	82,5	85,0	82,2	82,6	80,0	74,2	89
100 D	85,6	87,1	88,9	85,7	85,3	84,1	78,6	92

**WITH INVERTER LOW NOISE CONTROL\***
**Spectrum per octave band (dB(A))**

CSC/CSH CMC/CMH	63	125	250	500	1000	2000	4000	8000	Total sound power
									Lw dB(A)
20 S	64,6	66,1	68,2	66,8	67,8	65,5	64,7	58,8	73
25 S	66,1	69,6	70,4	69,0	67,1	67,5	64,5	63,0	74
30 S	67,3	71,9	72,0	72,4	69,7	70,6	67,6	66,3	77
35 S	67,9	70,4	71,5	71,2	67,9	69,0	65,8	61,3	75
40 S	67,8	70,2	71,2	70,7	67,7	68,9	65,4	61,8	75
45 D	68,3	72,2	73,6	73,9	70,8	71,5	70,6	66,1	78
55 D	74,3	76,1	71,8	73,8	70,2	72,6	68,7	67,7	78
70 D	75,1	76,5	72,9	75,2	71,7	72,9	69,9	65,6	79
85 D	75,3	76,8	73,5	76,0	72,7	73,8	70,9	66,8	80
100 D	73,5	76,6	78,1	79,9	76,5	76,4	75,0	70,5	83

Conditions: indoor temperature 21°C DB / 15°C WB; outdoor temperature: 25°C  
At minimum speed



## RADIATED NOISE LEVEL

### PACKAGED- STANDARD

#### Spectrum per octave band (dB(A))

CMC/CMH	125	250	500	1000	2000	4000	8000	Total sound power
								Lw dB(A)
20 S	70,5	71,6	70,7	70,9	67,0	65,8	58,6	77
25 S	80,5	73,4	71,0	71,0	70,9	67,6	61,2	79
30 S	83,0	75,3	71,9	73,2	74,9	70,3	64,1	80
35 S	80,9	75,7	71,7	72,7	72,7	67,6	59,4	79
40 S	81,1	76,7	73,7	74,5	74,0	67,5	61,2	81
45 D	83,6	79,2	77,1	75,9	75,0	71,5	65,3	82
55 D	86,8	76,5	73,8	74,5	77,6	73,0	66,6	82
70 D	87,0	78,3	75,9	76,2	76,1	71,1	63,2	82
85 D	87,5	79,3	77,8	77,7	77,4	71,2	64,9	83

### PACKAGED - WITH INVERTER LOW NOISE CONTROL\*

#### Spectrum per octave band (dB(A))

CMC/CMH	125	250	500	1000	2000	4000	8000	Total sound power
								Lw dB(A)
20 S	70,5	71,6	70,6	70,3	65,3	63,5	57,4	76
25 S	80,5	73,3	68,2	68,9	67,1	61,2	61,2	76
30 S	83,0	75,3	70,3	70,9	70,2	64,3	64,1	77
35 S	80,9	75,7	70,7	69,8	68,9	62,5	59,4	77
40 S	81,1	76,7	73,1	71,9	69,9	63,5	61,2	78
45 D	83,6	79,2	76,0	74,6	72,5	68,1	65,3	80
55 D	86,8	76,4	71,5	70,6	72,1	65,5	66,6	78
70 D	87,0	78,3	75,1	73,7	72,7	66,8	63,2	80
85 D	87,5	79,3	77,4	75,2	73,9	68,2	64,9	81

### SPLIT - STANDARD

#### Spectrum per octave band (dB(A))

CSC/CSH	125	250	500	1000	2000	4000	8000	Total sound power
								Lw dB(A)
20 S	67,5	71,1	70,0	70,2	66,6	65,7	58,6	75
25 S	79,7	72,3	68,9	68,4	70,4	67,4	61,0	76
30 S	82,5	74,4	69,3	71,0	74,7	70,2	63,9	79
35 S	80,5	73,4	67,5	70,7	72,1	67,3	58,5	77
40 S	80,3	73,1	67,2	71,8	73,1	66,6	59,8	78
45 D	82,8	76,0	72,4	71,7	73,8	71,2	64,1	79
55 D	86,7	74,2	71,7	73,4	77,5	72,9	66,5	82
70 D	86,6	74,8	70,9	73,9	75,4	70,5	61,9	80
85 D	86,9	75,4	71,2	75,1	76,6	70,4	63,3	81
100 D	86,7	80,0	74,7	76,4	77,8	73,5	65,8	83

Conditions: indoor temperature 21°C DB / 15°C WB; outdoor temperature: 25°C

At minimum speed

## RADIATED NOISE LEVEL

### SPLIT - WITH INVERTER LOW NOISE CONTROL\*

#### Spectrum per octave band (dB(A))

CSC/CSH	125	250	500	1000	2000	4000	8000	Total sound power
								Lw dB(A)
20 S	63,6	65,7	65,1	66,9	64,2	63,9	57,7	71
25 S	67,1	67,9	66,7	64,8	65,8	62,3	62,1	72
30 S	69,4	69,5	70,0	67,4	69,1	65,3	65,2	75
35 S	67,9	69,0	68,8	65,7	67,4	63,4	60,1	73
40 S	67,7	68,7	68,3	65,5	67,5	63,1	60,9	73
45 D	67,7	69,1	69,6	66,6	68,4	66,4	64,6	74
55 D	73,6	69,3	71,4	68,0	71,3	66,6	67,1	76
70 D	74,0	70,4	72,7	69,4	71,2	67,5	64,1	77
85 D	74,5	71,2	73,7	70,6	72,1	68,7	65,5	78
100 D	72,1	73,6	75,4	72,3	73,0	70,6	67,5	79

Conditions: indoor temperature 21°C DB / 15°C WB; outdoor temperature: 25°C

At minimum speed

### EXHAUST FAN SOUND LEVEL

SIZE	Lw dB(A) *
20 S --> 35 S	64
40 S --> 55 D	66
70 D - 85 D	73
100 D	76

\* Free field noise measurement at 1 meter.

**REFRIGERANT CHARGE** (indicated in grammes, for packaged units)

For split units, add the values indicated in the " EXTRA REFRIGERANT CHARGE R410A BY METER OF COPPER PIPE" table below.

Size		020	025	030	035	040	045	055	070	085	100
Cooling only	Circuit 1	4800	5950	6700	8650	10000	5700	6800	8600	10250	30000
	Circuit 2	-	-	-	-	-	5700	6800	8600	10250	9200
Heat pump	Circuit 1	5000	6150	6900	8950	10350	5850	7000	8850	10600	13450
	Circuit 2	-	-	-	-	-	5850	7000	8850	10600	9500

To locate the outdoor and the indoor units, refer to the following information :

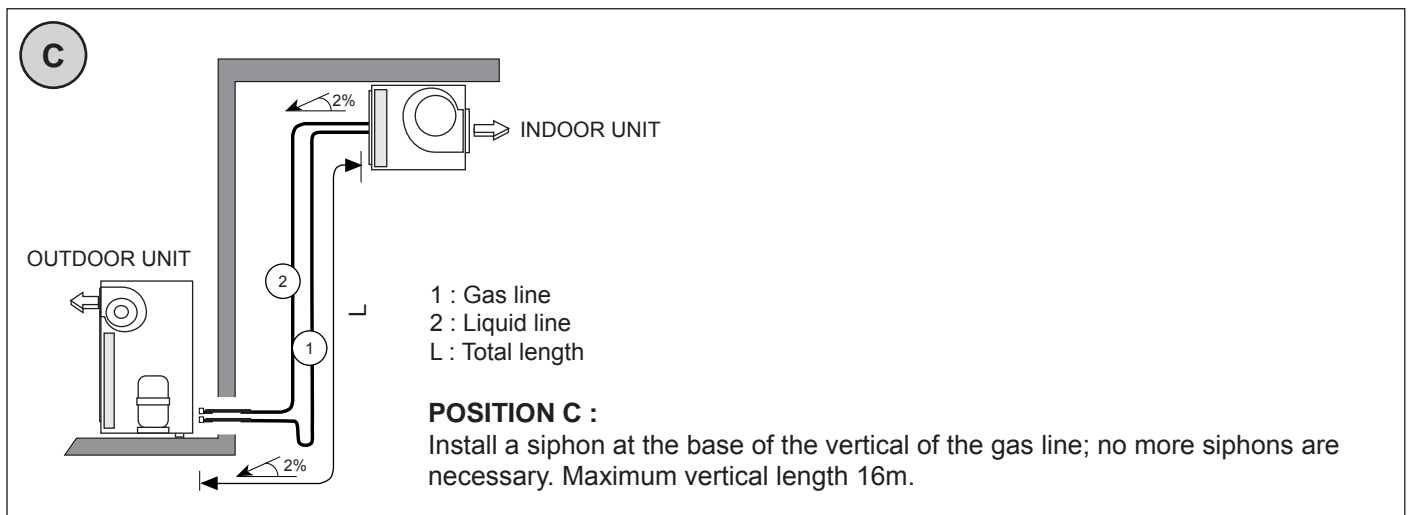
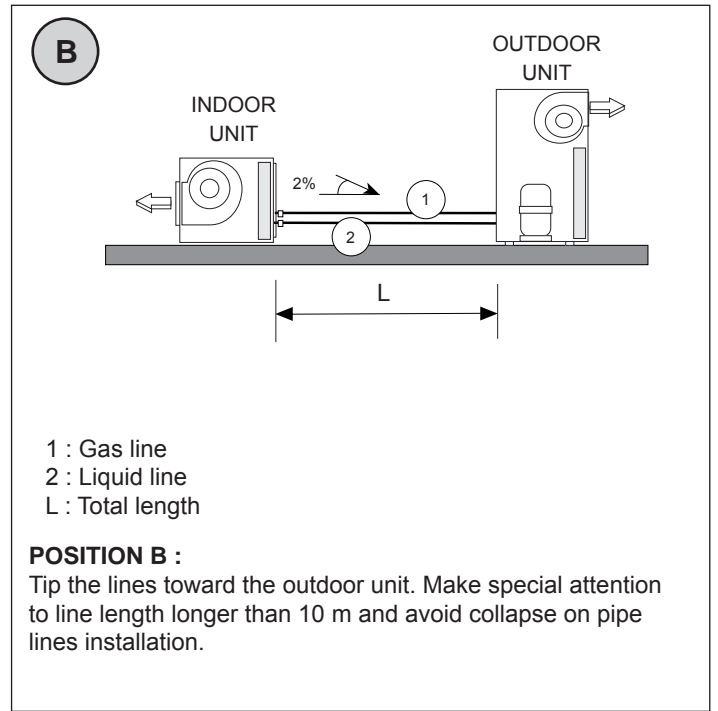
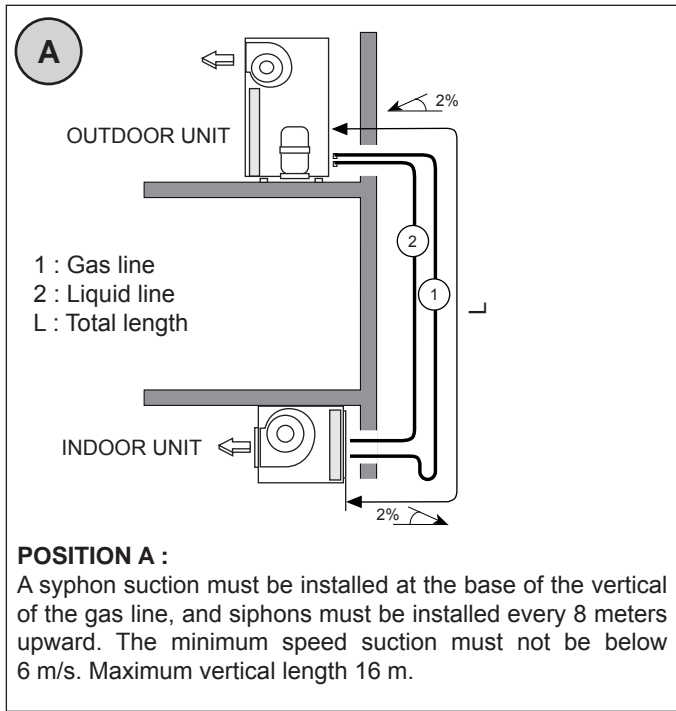

**EXTRA REFRIGERANT CHARGE R410A PER METER OF COPPER PIPE**

Liquid	Gas	gr/m
1/2"	7/8"	108
5/8"	1-1/8"	177
5/8"	1-3/8"	182
3/4"	1-3/8"	265
3/4"	1-5/8"	271
7/8"	1-5/8"	374

## REFRIGERANT LINES SELECTION

Refrigerant lines				Unit - Model										
				20 S	25 S	30 S	35 S	40 S	45 D	55 D	70 D	85 D	100 D	
Total line length (length refrigerant lines between indoor unit and outdoor unit)	0 ▶ 30 m.	Liquid Ø	C1	1/2"	5/8"	5/8"	5/8"	5/8"	5/8"	5/8"	5/8"	5/8"	5/8"	3/4"
			C2	n/a	n/a	n/a	n/a	n/a	5/8"	5/8"	5/8"	5/8"	5/8"	5/8"
		Gas Ø	C1	7/8"	1 1/8"	1 1/8"	1 3/8"	1 3/8"	1 1/8"	1 1/8"	1 3/8"	1 3/8"	1 3/8"	1 5/8"
			C2	n/a	n/a	n/a	n/a	n/a	1 1/8"	1 1/8"	1 3/8"	1 3/8"	1 3/8"	1 3/8"
	Maxi number of bends			6	12	8	18	12	12	8	18	12	12	
	30 ▶ 40 m.	Liquid Ø	C1	5/8"	5/8"	5/8"	3/4"	3/4"	5/8"	5/8"	3/4"	3/4"	7/8"	
			C2	n/a	n/a	n/a	n/a	n/a	5/8"	5/8"	3/4"	3/4"	3/4"	
		Gas Ø	C1	1 1/8"	1 1/8"	1 3/8"	1 3/8"	1 5/8"	1 1/8"	1 3/8"	1 3/8"	1 5/8"	1 5/8"	
			C2	n/a	n/a	n/a	n/a	n/a	1 1/8"	1 3/8"	1 3/8"	1 5/8"	1 5/8"	
	Maxi number of bends			12	18	18	18	18	18	18	18	18	12	
	40 ▶ 65 m (1).	Liquid Ø	C1	5/8"	5/8"	5/8"	3/4"	3/4"	5/8"	5/8"	3/4"	3/4"	7/8"	
			C2	n/a	n/a	n/a	n/a	n/a	5/8"	5/8"	3/4"	3/4"	3/4"	
Gas Ø		C1	1 1/8"	1 1/8"	1 3/8"	1 3/8"	1 5/8"	1 1/8"	1 3/8"	1 3/8"	1 5/8"	1 5/8"		
		C2	n/a	n/a	n/a	n/a	n/a	1 1/8"	1 3/8"	1 3/8"	1 5/8"	1 5/8"		
Maxi number of bends			12	18	18	18	18	18	18	18	18	12		

(1) : Long distance refrigerant connection option required.

**PACKAGED UNIT**

Table 7.1

COMPACTAIR CMC - CMH		20 S	25 S	30 S	35 S	40 S	45 D	55 D	70 D	85 D
Voltage		400V/3/50 Hz								
Maximum absorbed power	kW	10,4	13,9	16,4	20,9	22,3	28,9	31,7	41,4	49,8
Start-up current	A	89,8	101,3	108,6	144,0	157,7	130,4	136,7	178,1	207,2
Maximum current	A	19	27,9	30,3	35,2	40,6	57,1	58,4	69,4	90,3

**THERMODYNAMIC SECTION**

Table 7.2

COMPACTAIR CSC - CSH		20 S	25 S	30 S	35 S	40 S	45 D	55 D	70 D	85 D	100 D
Voltage		400V/3/50 Hz									
Maximum absorbed power	kW	9,7	11,99	14,49	18,19	19,59	23,83	28,98	36,38	41,06	50,25
Start-up current	A	88,4	97,8	105,1	139,1	152,7	121,8	131,9	169,5	191,9	207,9
Maximum current	A	17,59	24,45	26,8	30,4	35,8	48,48	53,6	60,8	74,96	91

**AIR TREATMENT SECTION**

Table 7.3

COMPACTAIR CIC - CIH (*)		20 S	25 S	30 S	35 S	40 S	45 D	55 D	70 D	85 D	100 D
Voltage		400V/3/50 Hz									
Maximum absorbed power	kW	0,74	1,45	1,45	1,89	2,69	2,69	2,69	3,63	5,06	5,06
Start-up current	A	6,4	13	13	17,3	26,4	26,4	26,4	35,6	60,2	60,2
Maximum current	A	1,4	2,6	2,6	3,5	4,8	4,8	4,8	6,5	8,6	8,6

(\*) : For dual split air treatment section sizes, please refer to below table.

**OPTIONS**

Table 7.4

COMPACTAIR - CMC / CMH	20 S		25 S		30 S		35 S		40 S	
	P	FLA	P	FLA	P	FLA	P	FLA	P	FLA
<b>Air treatment section - CIC/CIH</b>										
Standard supply fan	0	0	0	0	0	0	0	0	0	0
High pressure fan HP1	0,71	1,19	0,44	0,86	0,44	0,86	0,8	1,35	0	0
High pressure fan HP2	0,71	1,19	1,24	2,21	1,24	2,21	1,74	3,03	0,94	1,68
High pressure fan HP3	1,15	2,05	1,24	2,21	2,18	3,89	1,74	3,03	2,37	3,80
Exhaust module	0,51	2,6	0,51	2,6	0,51	2,6	1,33	6,8	1,33	6,8
Return module	-	-	-	-	-	-	-	-	-	-
Electrical heater - Standard	10	14,3	10	14,3	10	14,3	15	21,5	15	21,5
Electrical heater - Medium	15	21,5	15	21,5	15	21,5	20	28,6	20	28,6
Electrical heater - High	20	28,6	20	28,6	20	28,6	27	39	27	39

COMPACTAIR - CMC / CMH	45 D		55 D		70 D		85 D		100 D	
	P	FLA	P	FLA	P	FLA	P	FLA	P	FLA
<b>Air treatment section - CIC/CIH</b>										
Standard supply fan	0	0	0	0	0	0	0	0	0	0
High pressure fan HP1	0,94	1,68	0,94	1,68	1,43	2,12	1,32	2,5	1,32	2,5
High pressure fan HP2	2,34	3,80	2,37	3,80	2,75	4,62	3,73	6,70	5,06	8,60
High pressure fan HP3	2,37	3,80	3,69	6,30	5,16	8,82	3,73	6,70	5,06	8,60
Exhaust module	1,33	6,8	2,65	4,5	2,65	4,5	2,65	4,5	5,3	9
Return module	-	-	2,69	4,8	3,83	6,5	3,83	6,5	5,06	8,6
Electrical heater Standard	15	21,5	20	28,6	20	28,6	20	28,6	27	39
Electrical heater Medium	20	28,6	27	39	27	39	27	39	40	57,8
Electrical heater - High	27	39	40	57,8	40	57,8	40	57,8	50	72,3

<b>P</b>	Max. absorbed power in kW	<b>FLA</b>	Full load amps (A)
----------	---------------------------	------------	--------------------

COMPACTAIR		45D	55D	70D	85D	100D
Packaged	<b>CMC / CMH</b>					
Split	<b>CSC/CSH - CIC/CIH</b>					





- BEFORE MAKING ANY ELECTRICAL CONNECTIONS, ENSURE THAT ALL CIRCUIT BREAKERS ARE OPEN.
- IN ORDER TO CARRY OUT THE ELECTRICAL CONNECTIONS, FOLLOW THE ELECTRICAL DIAGRAM SUPPLIED WITH THE UNIT.

**SPLIT VERSION**

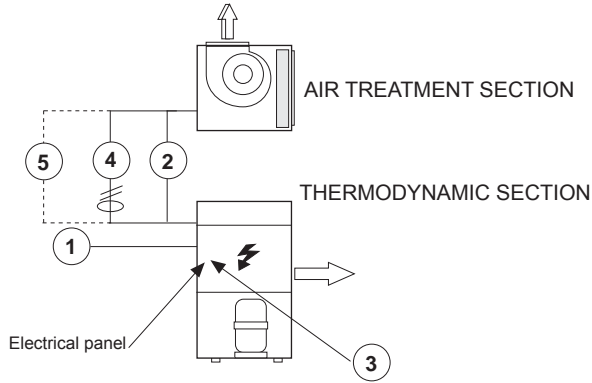

1	Electrical supply
2	Indoor fan motor electrical connection
3	Terminal connection (see electrical connection for the controller).
4	Discharge sensor
5	Electrical heater connection (optional).

**WIRING**

	Supply without electrical heater	Supply with electrical heater	Connection between outdoor units	Supply fan motor	Indoor coil sensor	Discharge sensor C60	Supply electrical heater (mm <sup>2</sup> )		
	1	1"		2	3	5	6		
							STANDARD	MEDIUM	HIGH
020	4 x 4 mm <sup>2</sup>	4 x 10 mm <sup>2</sup>	4 x 1.5 mm <sup>2</sup>	4 x 1.5 mm <sup>2</sup>	2 x 1 mm <sup>2</sup> shielded	2 x 1 mm <sup>2</sup> shielded	4 x 2.5 + 4 x 1.5 mm <sup>2</sup>	4 x 4 + 4 x 1.5 mm <sup>2</sup>	4 x 6 + 4 x 1.5 mm <sup>2</sup>
025	4 x 6 mm <sup>2</sup>	4 x 16 mm <sup>2</sup>							
030	4 x 6 mm <sup>2</sup>	4 x 16 mm <sup>2</sup>							
035	4 x 6 mm <sup>2</sup>	3 x 25 + 2 x 16 mm <sup>2</sup>							
040	4 x 10 mm <sup>2</sup>	3 x 25 + 2 x 16 mm <sup>2</sup>			4 x 1 mm <sup>2</sup> shielded	4 x 1 mm <sup>2</sup> shielded	4 x 4 + 4 x 1.5 mm <sup>2</sup>	4 x 6 + 4 x 1.5 mm <sup>2</sup>	4 x 10 + 4 x 1.5 mm <sup>2</sup>
045	4 x 16 mm <sup>2</sup>	3 x 35 + 2 x 16 mm <sup>2</sup>							
055	4 x 16 mm <sup>2</sup>	3 x 50 + 2 x 25 mm <sup>2</sup>			4 x 1.5 mm <sup>2</sup> (STD & HP1) 4 x 2.5 mm <sup>2</sup> (HP2 & HP3)	4 x 1 mm <sup>2</sup> shielded	4 x 6 + 4 x 1.5 mm <sup>2</sup>	4 x 10 + 4 x 1.5 mm <sup>2</sup>	4 x 16 + 4 x 1.5 mm <sup>2</sup>
070	3 x 25 + 1 x 16 mm <sup>2</sup>	3 x 70 + 1 x 35 mm <sup>2</sup>							
085	3 x 25 + 1 x 16 mm <sup>2</sup>	3 x 70 + 1 x 35 mm <sup>2</sup>							
100	3 x 35 + 1 x 16 mm <sup>2</sup>	3 x 95 + 1 x 50 mm <sup>2</sup>	2 x (4 x 4 mm <sup>2</sup> ) + 10 x 1.5 mm <sup>2</sup> + 6 x 1 mm <sup>2</sup>	4 x 10 + 4 x 1.5 mm <sup>2</sup>	4 x 16 + 4 x 1.5 mm <sup>2</sup>	4 x 25 + 4 x 1.5 mm <sup>2</sup>			

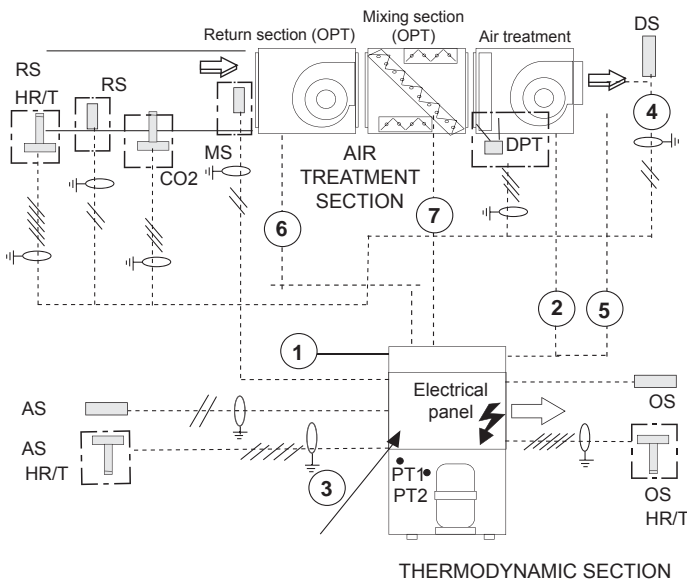
**SPLIT VERSION WITH ECONOMIZER**

1	Electrical supply
2	Indoor motor fan electrical connection
3	Terminal connection (see electrical connection for the controller)
4	Discharge sensor
5	Electrical heater connection (option)
6	Exhaust fan or return fan connection
7	Free-cooling connection

**CONTROL CONNECTION ELEMENTS:**

COMPONENTS		C60	No. of cables X section
DS	Discharge sensor	STANDARD	2 x 1 mm <sup>2</sup> (shielded)
OS	Outdoor sensor		
AS	Remote ambient sensor		
RS	Duct sensor. Replaces AS		
IS	Liquid-gas pipe sensor	STANDARD	5 x 1 mm <sup>2</sup> (shielded)
MS	Duct sensor for thermostatic and enthalpic free cooling	OPTION	
RS HR/T	Duct remote sensor for enthalpic free cooling	OPTION	
CO <sub>2</sub>	CO <sub>2</sub> Air quality probe available only with enthalpic free cooling		
DPT	Differential air pressure transducer)		
OS HR/T	Outdoor sensor for enthalpic free cooling		
AS HR/T	Remote ambient sensor for enthalpic free cooling		5 x 1 mm <sup>2</sup> (shielded)

**RETURN AND EXHAUST FAN CONNECTIONS**

	020	025 > 040	45	055 > 085	100
Exhaust fan	3 x 1,5 mm <sup>2</sup>			4 x 1,5 mm <sup>2</sup>	
Return fan				4 x 1,5 mm <sup>2</sup>	4 x 2,5 mm <sup>2</sup>

**FREE-COOLING CONNECTION**

Version	
C60	7 x 1,5 mm <sup>2</sup>

**VOLTAGE OPERATING LIMITS: 342-462V**

EXAMPLE OF THERMOSTAT WIRING (CHECK THE WIRING DIAGRAM OF THE UNIT)

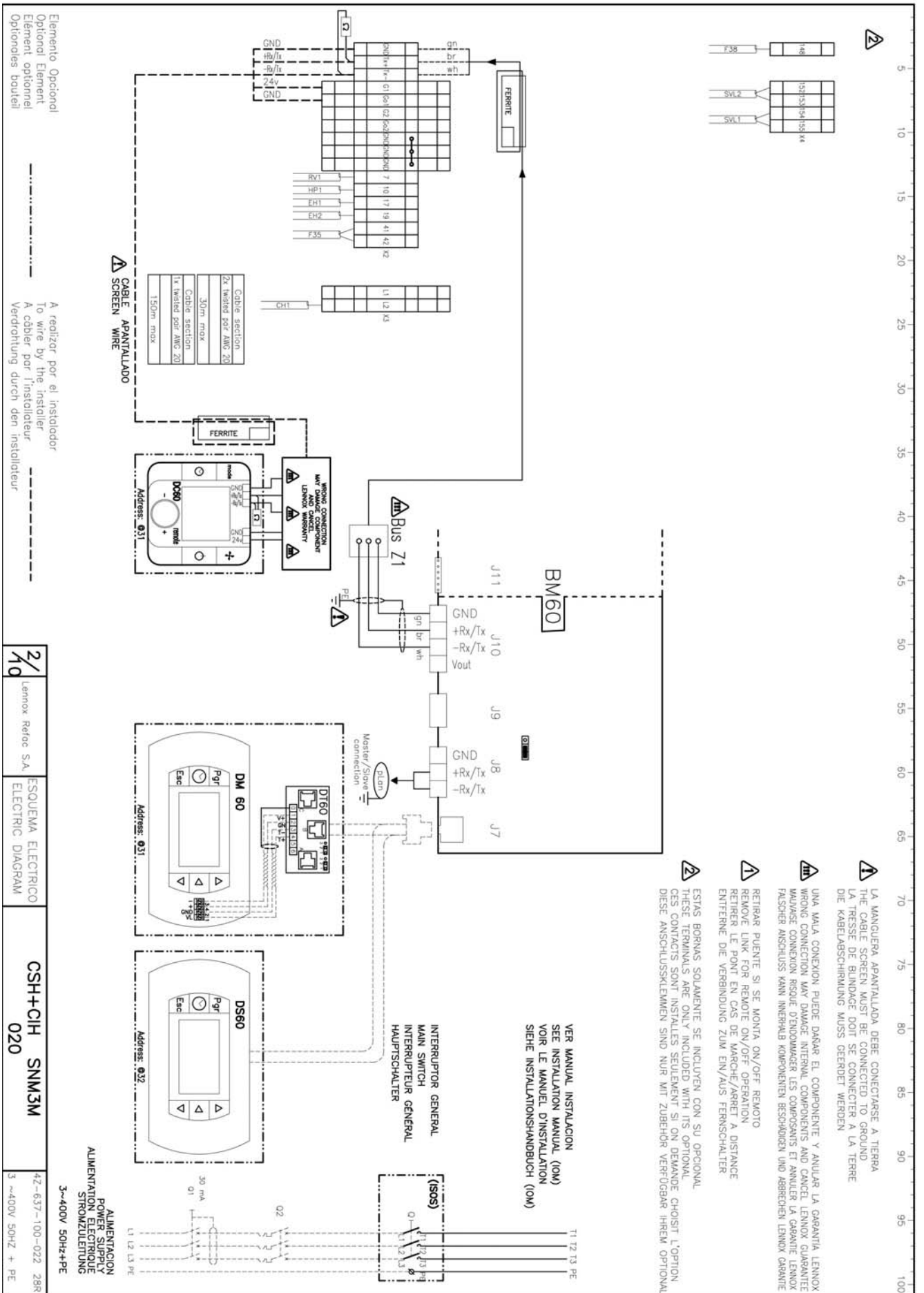

## EXAMPLE OF THERMOSTAT WIRING / SENSORS IN ONE CIRCUIT UNITS (CHECK THE WIRING DIAGRAM OF THE UNIT)

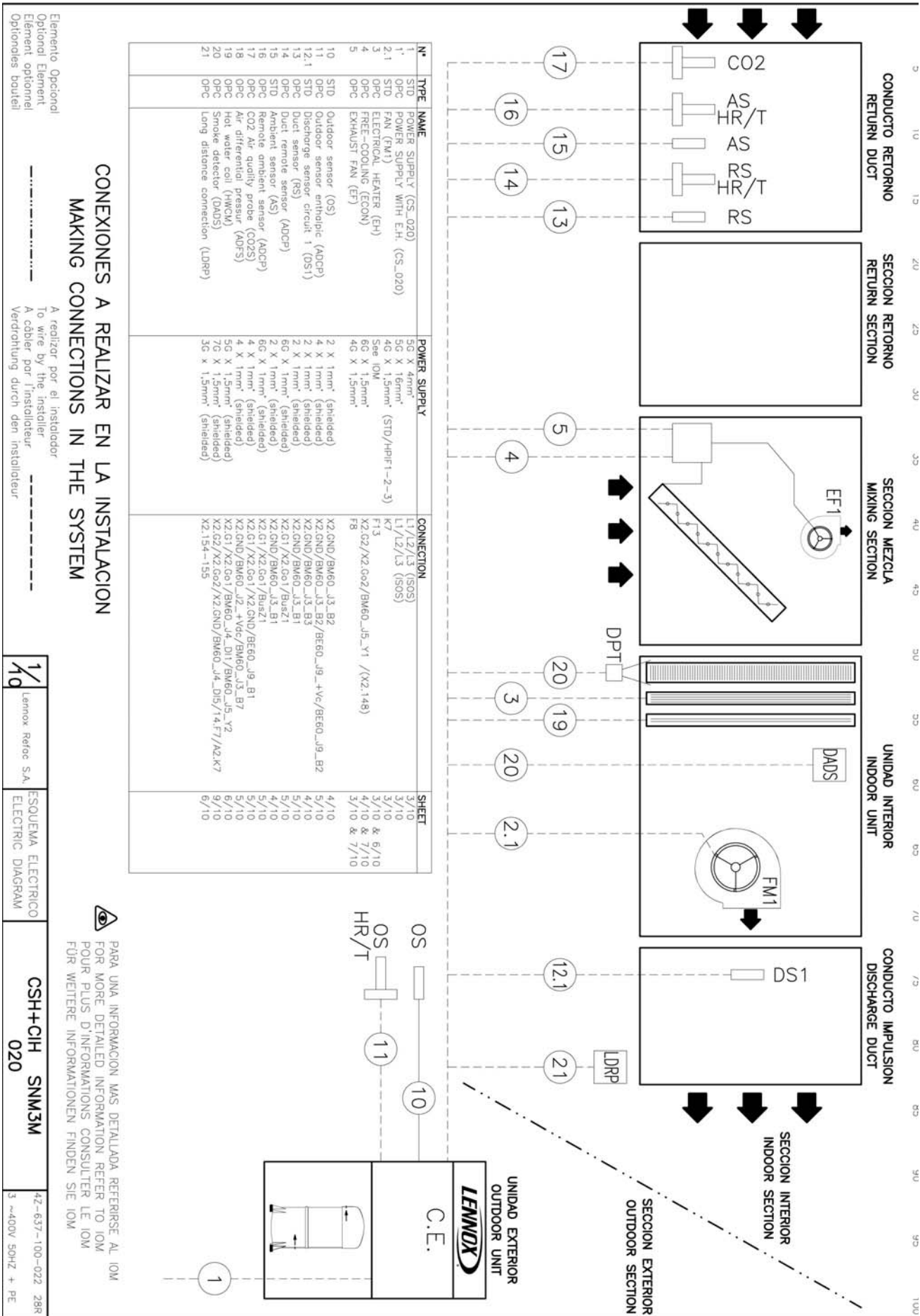

EXAMPLE OF THERMOSTAT WIRING / SENSORS IN DOUBLES CIRCUITS UNITS (CHECK THE WIRING DIAGRAM OF THE UNIT)

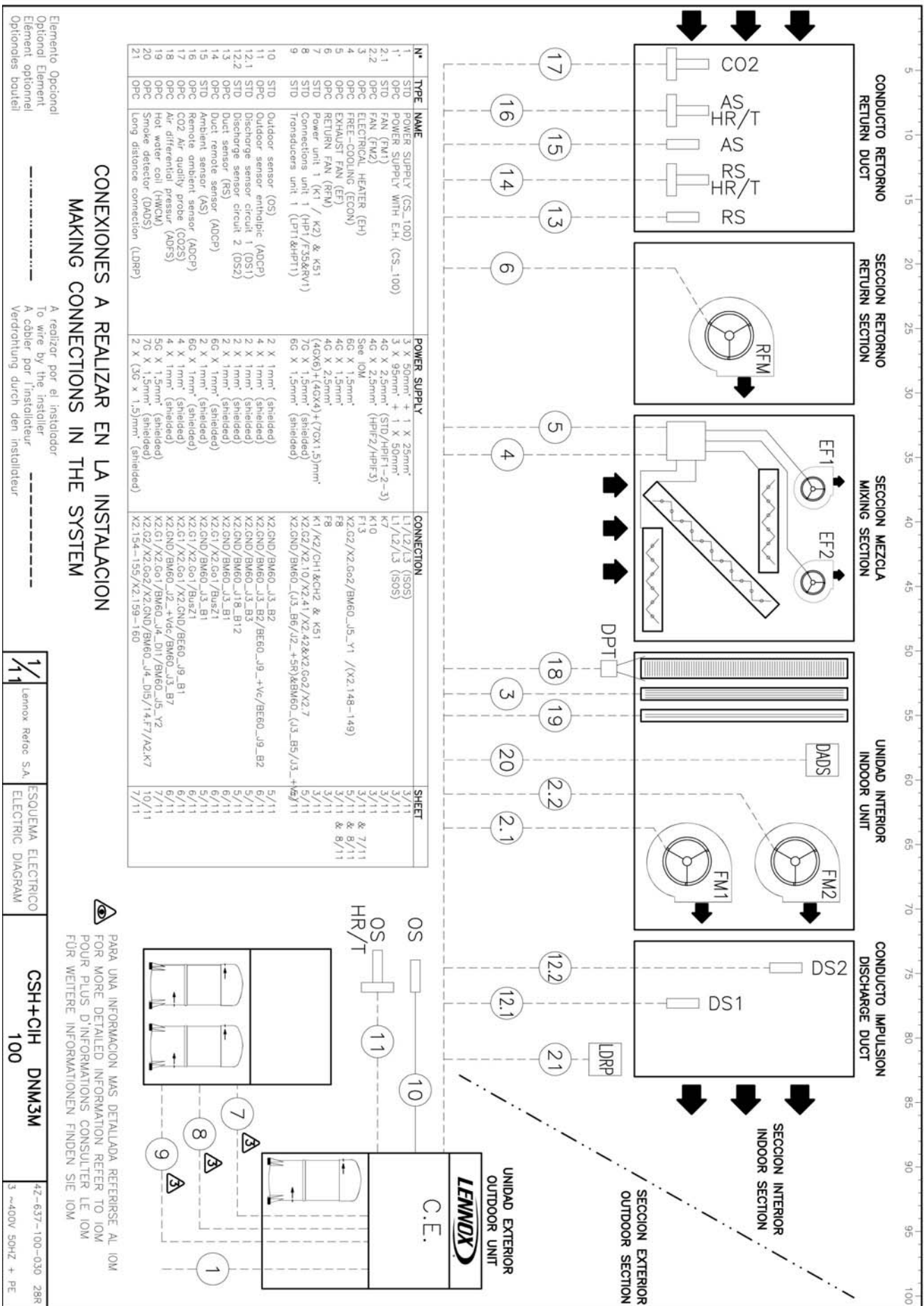



## A BOX &amp; B BOX

## 20S/25S/30S &amp; 35S/40S/45S

## SPLIT - STANDARD HORIZONTAL DISCHARGE

## THERMODYNAMIC SECTION

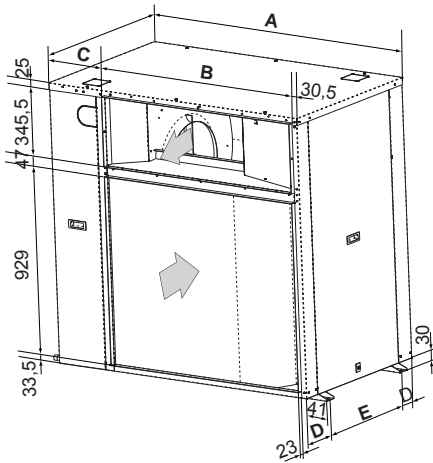

## AIR TREATMENT SECTION

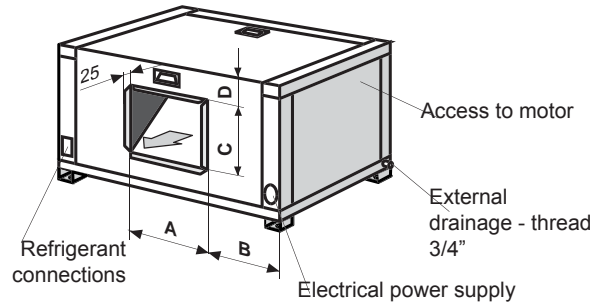

	A BOX	B BOX
	020S - 025S - 030 S	035S - 040S - 045S
A	1194	1445
B	1000	1093
C	163,5	321,5
D	102,5	133
E	540	600

	A BOX	B BOX
	020S - 025S - 030 S	035S - 040S - 045S
A	400	534
B	387	455,5
C	346	467
D	190	188,5

## SPLIT - OPTIONAL VERTICAL DISCHARGE

## THERMODYNAMIC SECTION

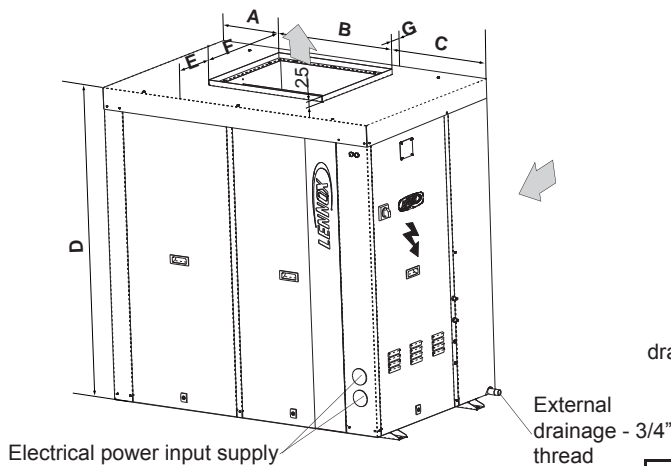

## AIR TREATMENT SECTION

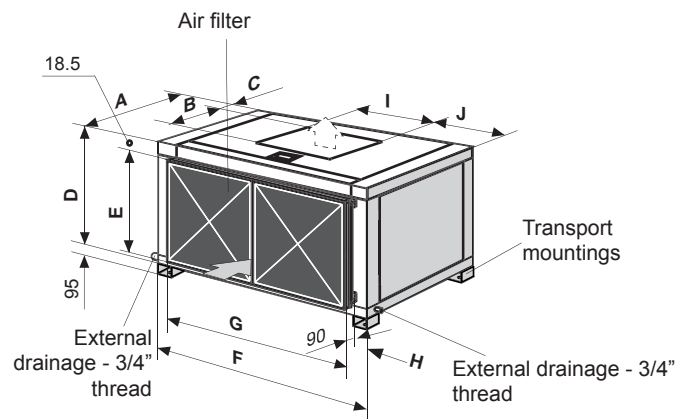

	A BOX	B BOX
	020S - 025S - 030 S	035S - 040S - 045S
A	371,5	420
B	564	622
C	288,5	403
D (1)	1410	1500
E	204,5	252,5
F	467	543
G	77,5	74,5

	A BOX	B BOX
	020S - 025S - 030 S	035S - 040S - 045S
A	750	870
B	346	470
C	191	3
D	645	740
E	603	695
F	1195	1445
G	1005	1260
H	104	140
I	400	534
J	407	455,5



A BOX & B BOX

20S/25S/30S & 35S/40S/45S

PACKAGED - STANDARD VERTICAL DISCHARGE

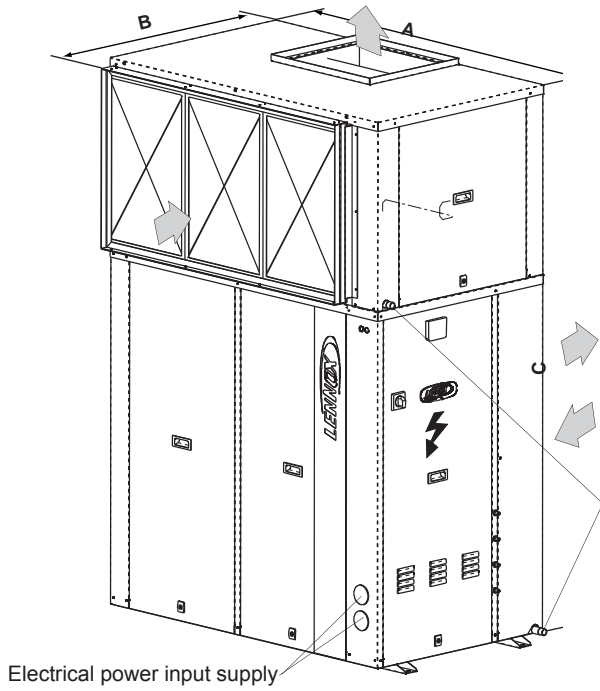

	A BOX	B BOX
	020S - 025S - 030 S	035S - 040S - 045D
<b>A</b>	1194	1445
<b>B</b>	840	960
<b>C (1)</b>	2025	2170

(1) Including unit's support

PACKAGED - OPTIONAL HORIZONTAL DISCHARGE

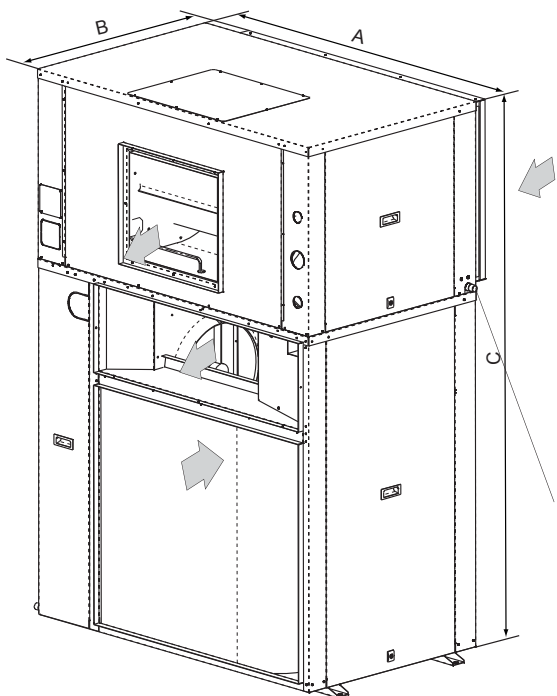

	A BOX	B BOX
	020 - 025 - 030 S	035S - 040S - 045D
<b>A</b>	1194	1445
<b>B</b>	840	960
<b>C(1)</b>	2055	2145

(1) Including unit's support

C BOX

55D/70D/85D

**STANDARD HORIZONTAL DISCHARGE**

**THERMODYNAMIC SECTION**

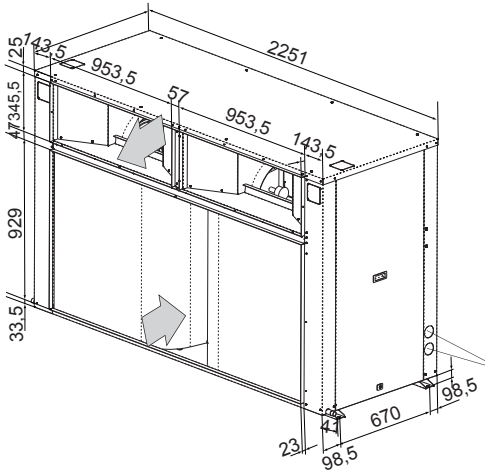

**AIR TREATMENT SECTION**

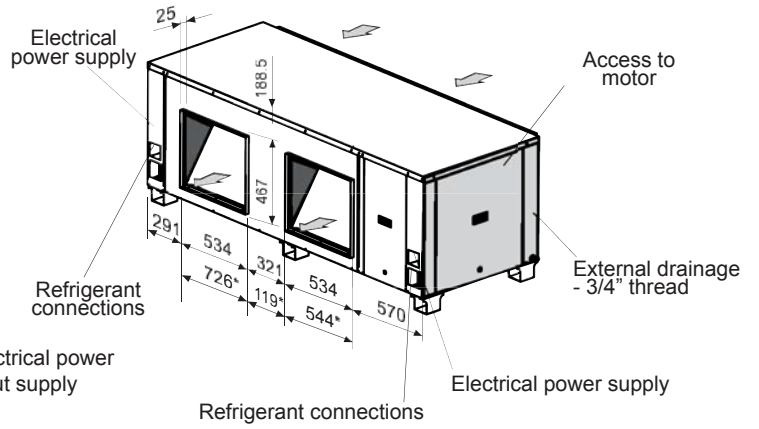

\* For HP2 & HP3

**OPTIONAL VERTICAL DISCHARGE**

**THERMODYNAMIC SECTION**

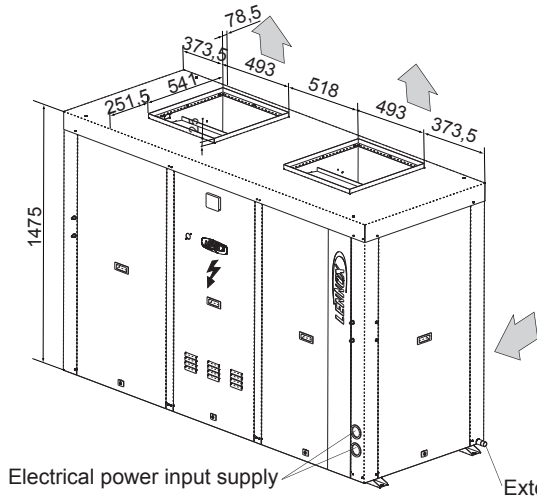

**AIR TREATMENT SECTION**

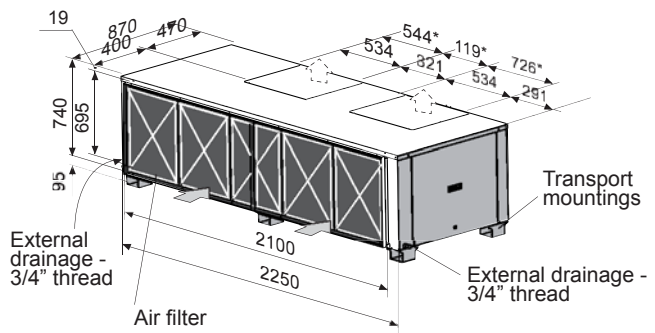

\* For HP2 & HP3

**PACKAGED - STANDARD VERTICAL DISCHARGE**

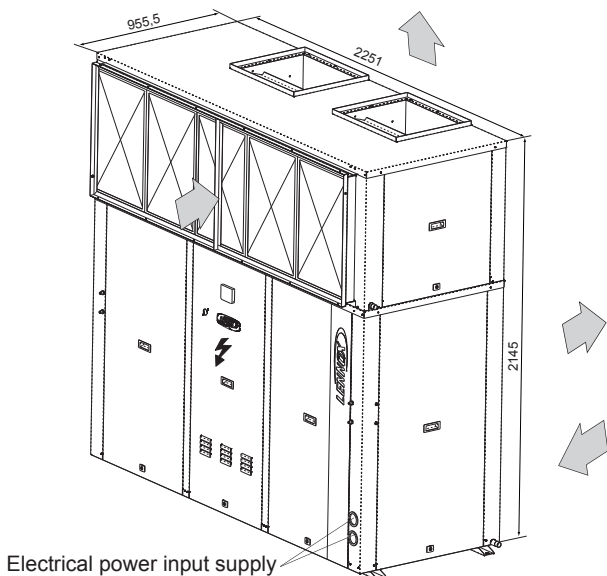

**PACKAGED - OPTIONAL HORIZONTAL DISCHARGE**

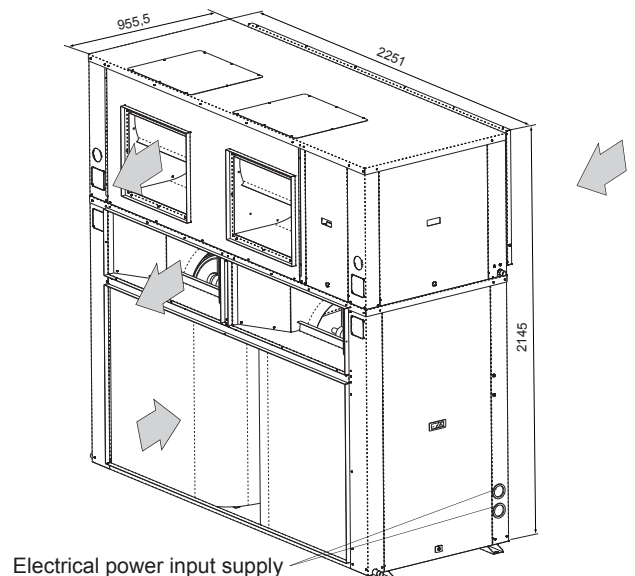

D BOX

100D

STANDARD HORIZONTAL DISCHARGE

THERMODYNAMIC SECTION

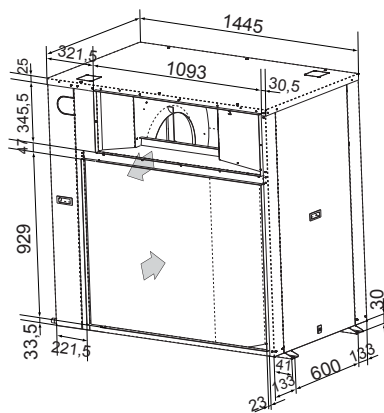
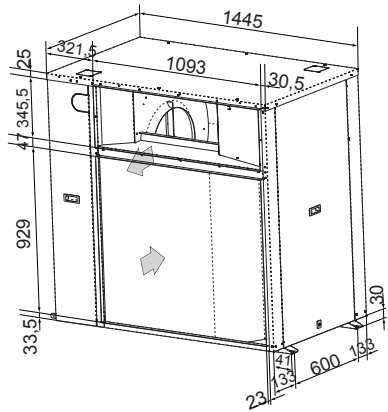

AIR TREATMENT SECTION

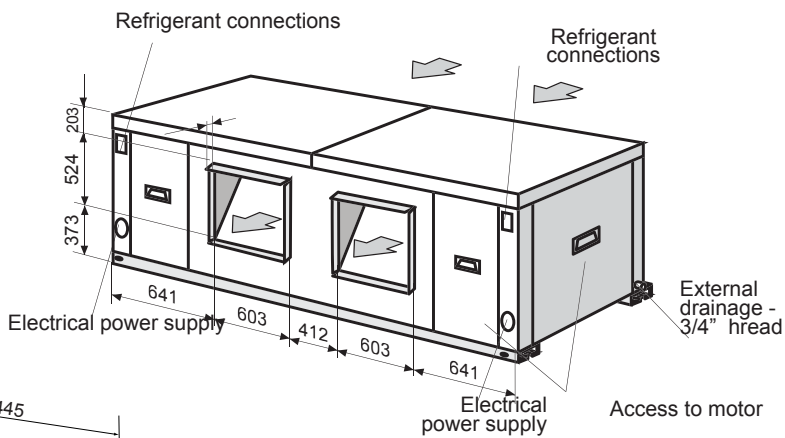

OPTIONAL VERTICAL DISCHARGE

THERMODYNAMIC SECTION

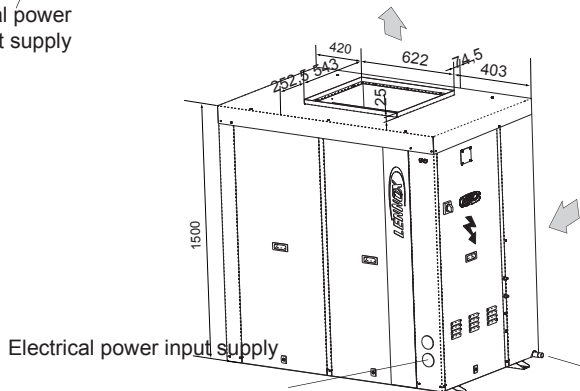
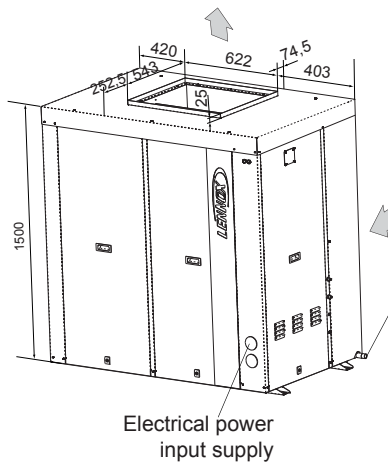

AIR TREATMENT SECTION

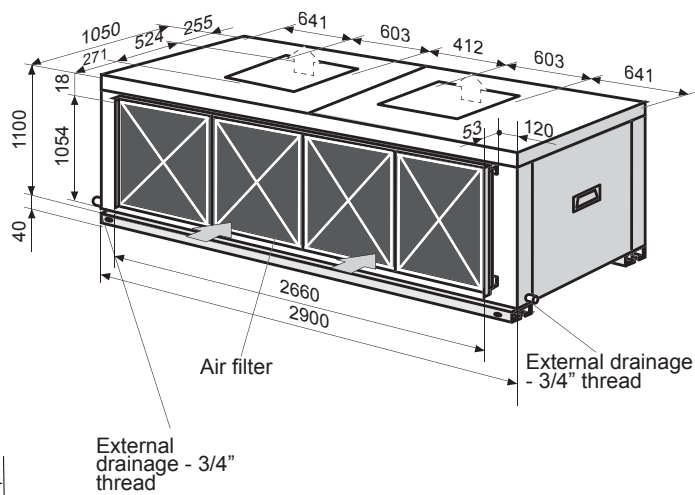

A BOX & B BOX

20S/25S/30S & 35S/40S/45S

ECONOMIZER + EXHAUST FANS

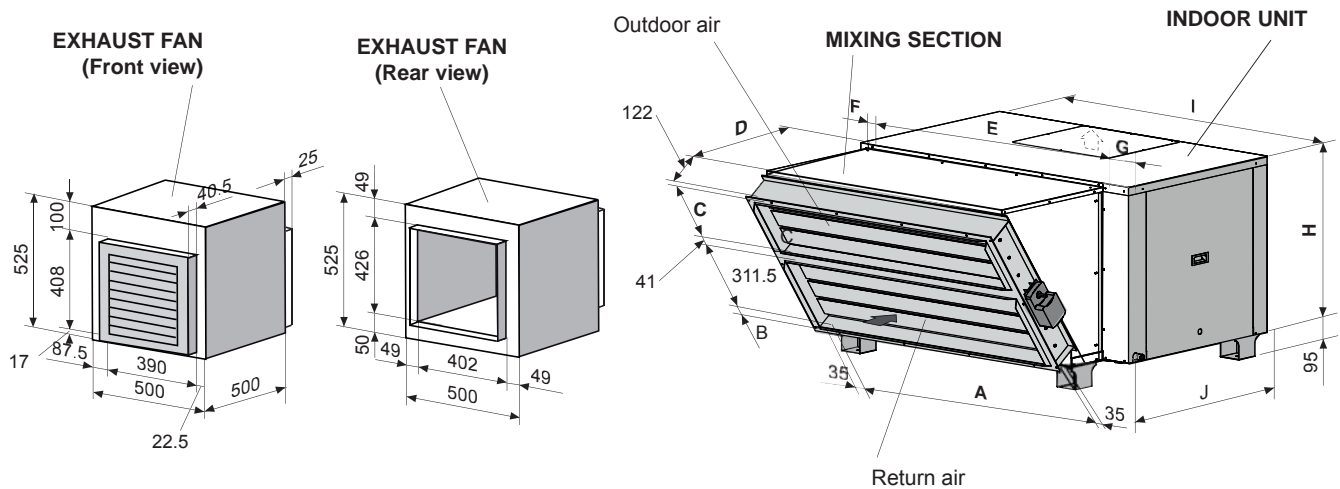

The damper position may be different from that shown in the illustration. See drawings.

	A BOX	B BOX		A BOX	B BOX
	020 - 025 - 030 S	035S - 040S - 045S		020 - 025 - 030 S	035S - 040S - 045S
<b>A</b>	1000	1250	<b>F</b>	80,5	41
<b>B</b>	25	19,5	<b>G</b>	100,5	136
<b>C</b>	147,5	229,5	<b>H</b>	645	740
<b>D</b>	648	642	<b>I</b>	1195	1445
<b>E</b>	1013	1268	<b>J</b>	750	870

C BOX

055D/070D/085D

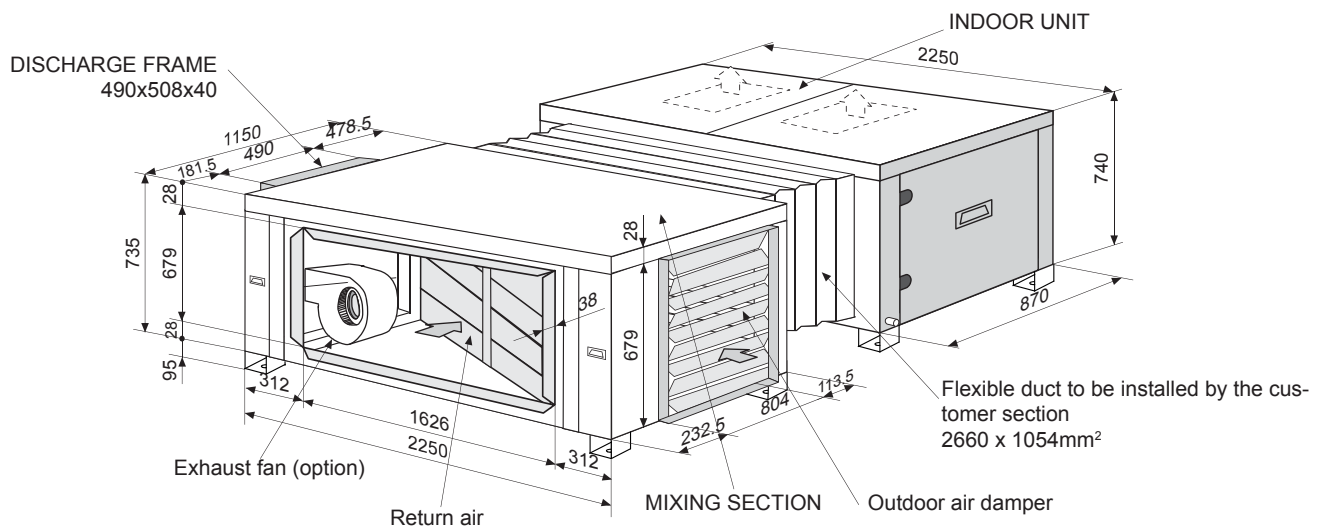

It is possible to include an exhaust fan with free cooling without return fan.

## ECONOMIZER + EXHAUST FANS

### D BOX

100D

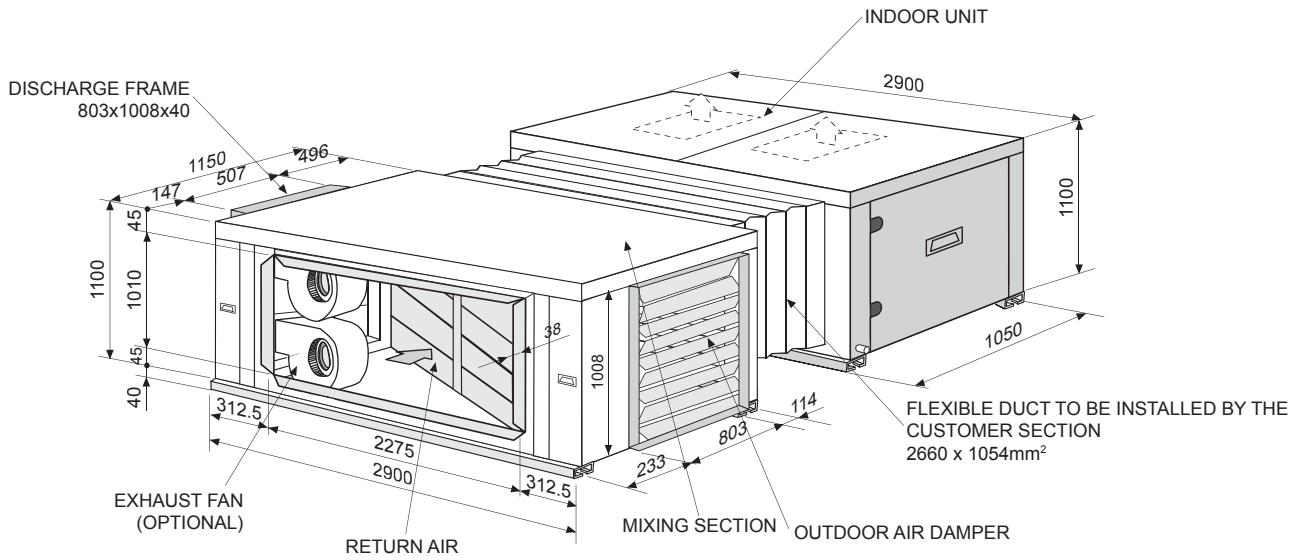

## RETURN FAN MODULE

### 055D/070D/085D/100D

MODELS	055D/070D/085D	100D
A	2250	2571
B	28	45
C	28	45
D	650	700
E	1626	2275
F	312	148
G	312	148
H	735	1100
I	679	1010
J	95	40

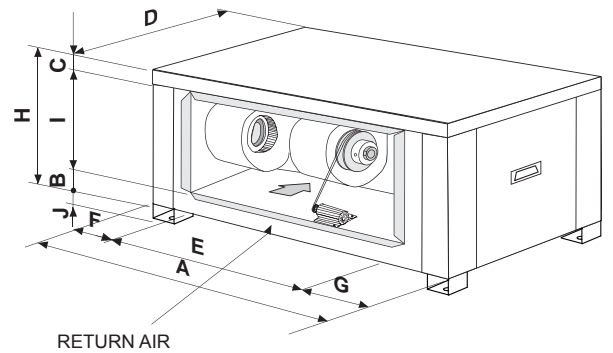

## CLEARANCES

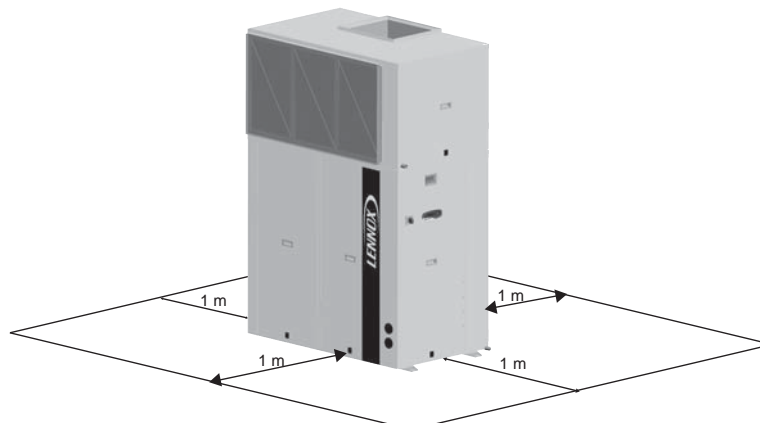



**REMINDER - UNIT CONFIGURATIONS**

COMPACTAIR		20S	25S	30S	35S	40S	45D	55D	70D	85D	100D
Packaged	CMC / CMH										
Split	CSC/CSH - CIC/CIH										

**OPERATING WEIGHTS**
**PACKAGED UNIT**

COMPACTAIR	CMC CMH	20 S	25 S	30 S	35 S	40 S	45 D	55 D	70 D	85 D
Standard unit - CMC Cooling only	kg	371	407	418	510	533	623	779	824	876
Standard unit - CMH Heat pump	kg	376	412	424	516	539	630	785	831	883
Air sock control	kg	2	2	2	2	2	2	2	3	3
Electrical heater	kg	10	10	10	10	10	20	20	20	30
Economizer	kg	50	50	50	75	75	75	165	165	165
Hot water coil	kg	10	10	10	12	16	20	20	24	30
High pressure fan motor indoor HP1	kg	6.5	3	3	5	0	3	3	3	13
High pressure fan motor indoor HP2	kg	6,5	3	8	8	3	6	6	16	21
High pressure fan motor indoor HP3	kg	9,5	8	11	8	6	6	19	24	21
Exhaust fan	kg	25	25	25	28	28	28	37	37	37
Low noise	kg	2	2	2	2	2	3	4	4	7
High filtration level G4 prefilter / F7 filtration	kg	6	6	6	9	9	9	14	14	14

**THERMODYNAMIC SECTION**











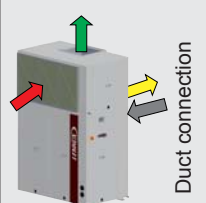

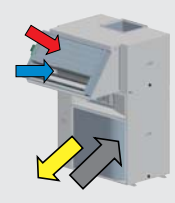
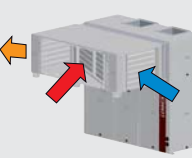

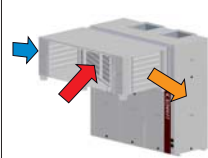

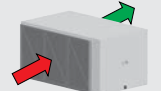
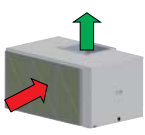
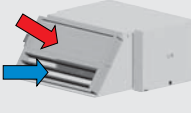
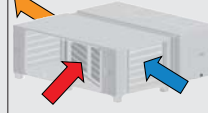
COMPACTAIR CSC/CSH		20 S	25 S	30 S	35 S	40 S	45 D	55 D	70 D	85 D	100 D
CSC/CDC - Cooling only	kg	257	290	297	352	365	443	524	549	581	865
CSH/CDH - Heat pump	kg	262	295	302	357	370	448	529	554	586	870
Low noise	kg	2	2	2	2	2	3	4	4	7	5
Long distance refrigerant connection (65 m)	kg	2	6	6	4	4	12	12	8	8	12
Refrigerant precharge* Cooling only	kg	5,5	5,5	6,2	8,0	8,3	10,4	12,9	16,0	18,6	23,4
Refrigerant precharge* Heat pump	kg	5,8	6,1	6,9	8,9	9,2	11,5	14,3	17,7	20,7	25,8

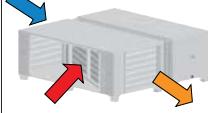
\* Available as an option

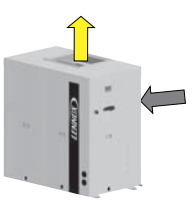
**AIR TREATMENT SECTION**

COMPACTAIR	CIC CIH	20	25	30	35	40 S	45 D	55 D	70 D	85 D	100 D
Air treatment section	kg	108	111	115	150	160	170	242	259	276	470
Air sock control	kg	2	2	2	2	2	2	2	3	3	3
Electrical heater	kg	10	10	10	10	10	20	20	20	30	45
Economizer	kg	50	50	50	75	75	75	165	165	165	190
Hot water coil	kg	10	10	10	12	16	20	20	24	30	40
High pressure fan motor indoor HP1	kg	6.5	3	3	5	0	3	3	3	13	13
High pressure fan motor indoor HP2	kg	6,5	3	8	8	3	6	6	16	21	27
High pressure fan motor indoor HP3	kg	9,5	8	11	8	6	6	19	24	21	27
Exhaust fan	kg	25	25	25	28	28	28	37	37	37	65
High filtration level G4 prefilter / F7 filtration	kg	6	6	6	9	9	9	14	14	14	23

**PACKAGED**

	Standard	Optional	With economizer standard configuration		With economizer configuration as option		
			A & B Box	C Box	A & B Box	C Box	
			20S - 45D	55D - 85D	20S - 45D	55D - 85D	
Packaged	Upflow supply 	Horizontal supply 	Fresh air bottom Return air above 	Fresh air right Exhaust air left 	Position front 	Fresh air left Exhaust air right 	
				<p><b>BE CAREFUL:</b> ON A &amp; B BOXES, IF YOU ADD AN ECONOMIZER, THE CONDENSING UNIT CONFIGURATION IS DIFFERENT</p>		Fresh air above Return air bottom 	
						Position front 	
Air treatment section Split	Horizontal supply 	Upflow supply 	A & B Box Split 20S - 45D	C Box Split 55D - 100D	A & B Box Split 20S - 45D	C Box Split 55D - 100D	
			Fresh air bottom Return air above 	Fresh air right Exhaust air left 	Fresh air above Return air bottom 	Fresh air left Exhaust air right 	
Thermodynamic section Split		Vertical discharge 	<p><b>AIR TREATMENT SECTION</b></p> <p> Fresh air                       Exhaust air</p> <p> Return air                          Supply air</p> <p><b>THERMODYNAMIC SECTION</b></p> <p> Outdoor air suction                       Outdoor air exhaust</p>				

## SALES OFFICES :

### BELGIUM AND LUXEMBOURG

+32 3 633 3045

### FRANCE

+33 1 64 76 23 23

### GERMANY

+49 (0) 211 950 79 60

### ITALY

+39 02 495 26 200

### NETHERLANDS

+31 332 471 800

### POLAND

+48 22 58 48 610

### PORTUGAL

+351 229 066 050

### SPAIN

+34 915 401 810

### UKRAINE

+38 044 585 59 10

### UNITED KINGDOM AND IRELAND

+44 1604 669 100

### OTHER COUNTRIES :

#### LENNOX DISTRIBUTION

+33 4 72 23 20 20

