

# Application guide

## INNOV@ - EC Plug Fan



- Providing IT Climate Technology





## CONTENTS

<b>General Description</b>	2
<b>Digit configuration</b>	7
<b>Main characteristics &amp; features</b>	9
<b>Application field</b>	15
<b>Technical section</b>	17
<b>Free-Cooling</b>	18
<b>Re-heating systems and capacity control</b>	18
<b>DX Air Cooled Units Technical Data</b>	24
<b>DX Water Cooled Units Technical Data</b>	30
<b>CW Units Technical Data</b>	36
<b>Remote Condensers</b>	38
<b>Remote Dry Coolers</b>	42
<b>Correction factors</b>	44
<b>Refrigerant pipes</b>	45
<b>Interconnectivity systems</b>	46

## 1. GENERAL DESCRIPTION

DHA..R	➔ Direct Expansion Up/Down Flow
DHW..R	➔ Direct Expansion Water condensed Up/Down Flow
DHZ..R	➔ Direct Expansion City Water condensed Up/Down Flow
DHF..R	➔ Direct Expansion Indirect Free Cooling Up/Down Flow
DHQ..R	➔ Dual Cooling Water condensed Up/Down Flow
DHD..R	➔ Dual Cooling Air condensed Up/Down Flow
DHC..R	➔ Chilled Water Up/Down Flow
DH..XR	➔ Displacement Version

# Example of a DX Air Cooled Unit Type: DHADR

6 – 22 kW

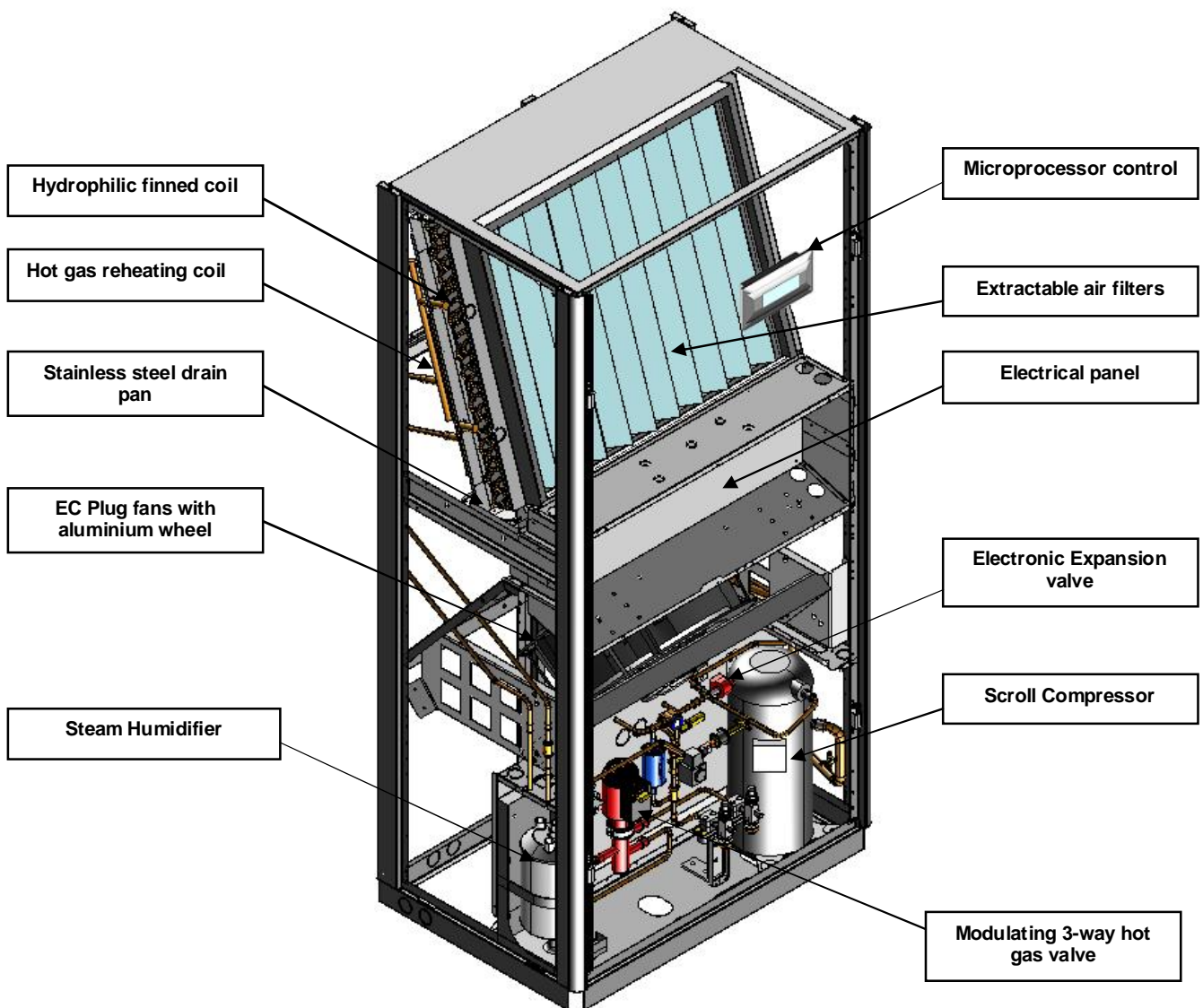
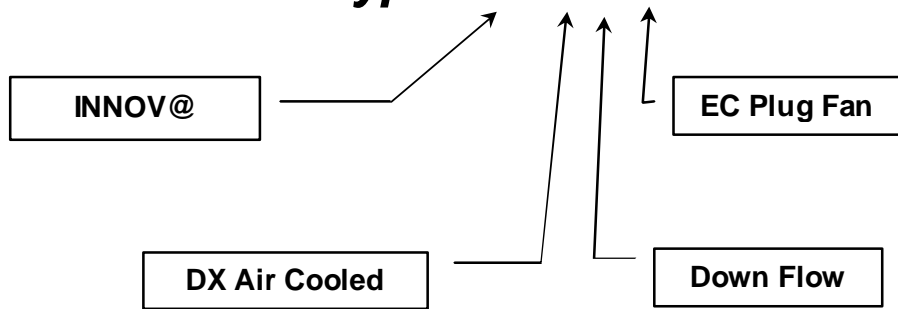

**Example of a DX Air Cooled Unit Type DHADR:**

**22 – 80 kW**

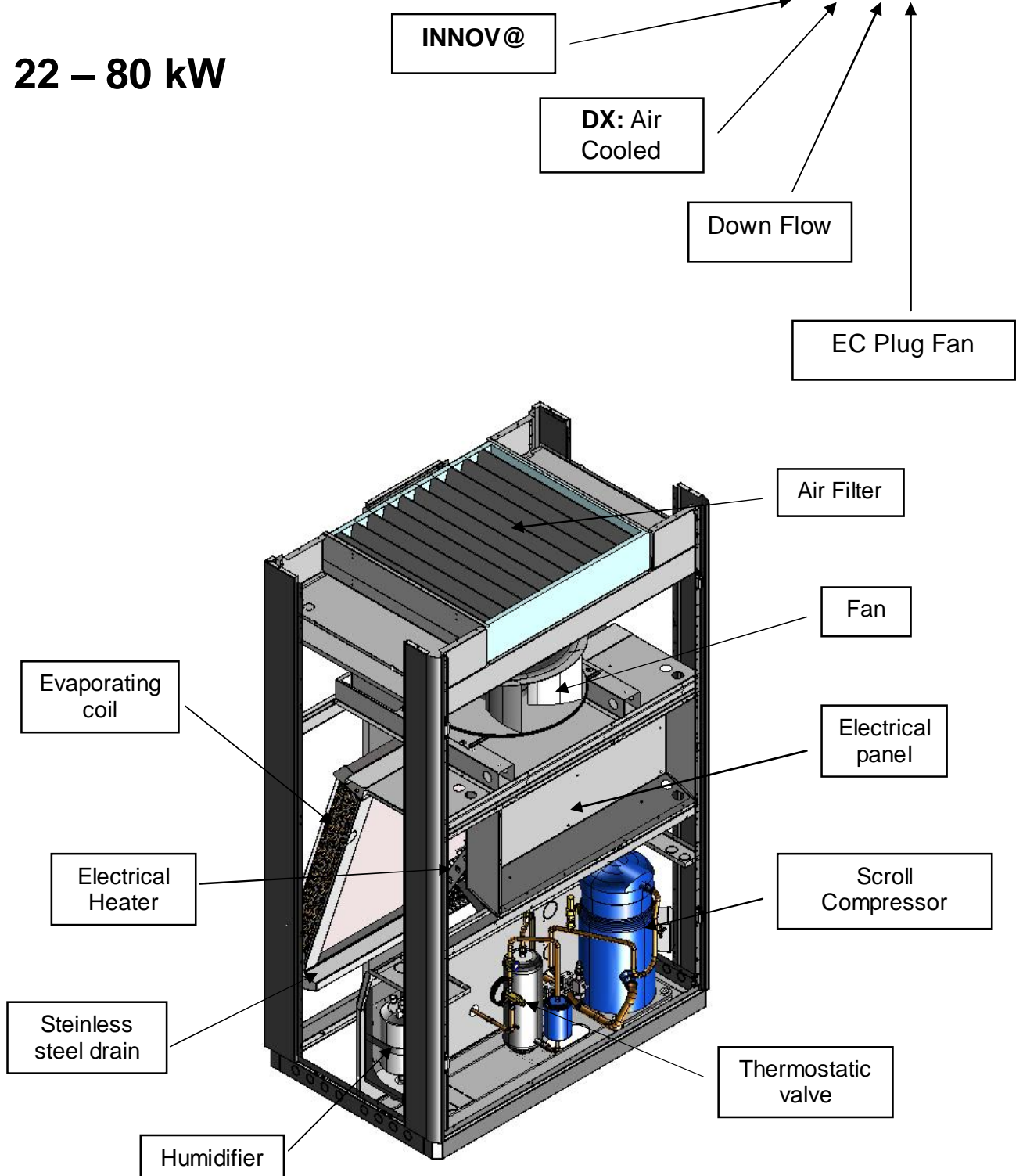

# Example of a Chilled Water Unit Type: DHCDR

7 – 23 kW

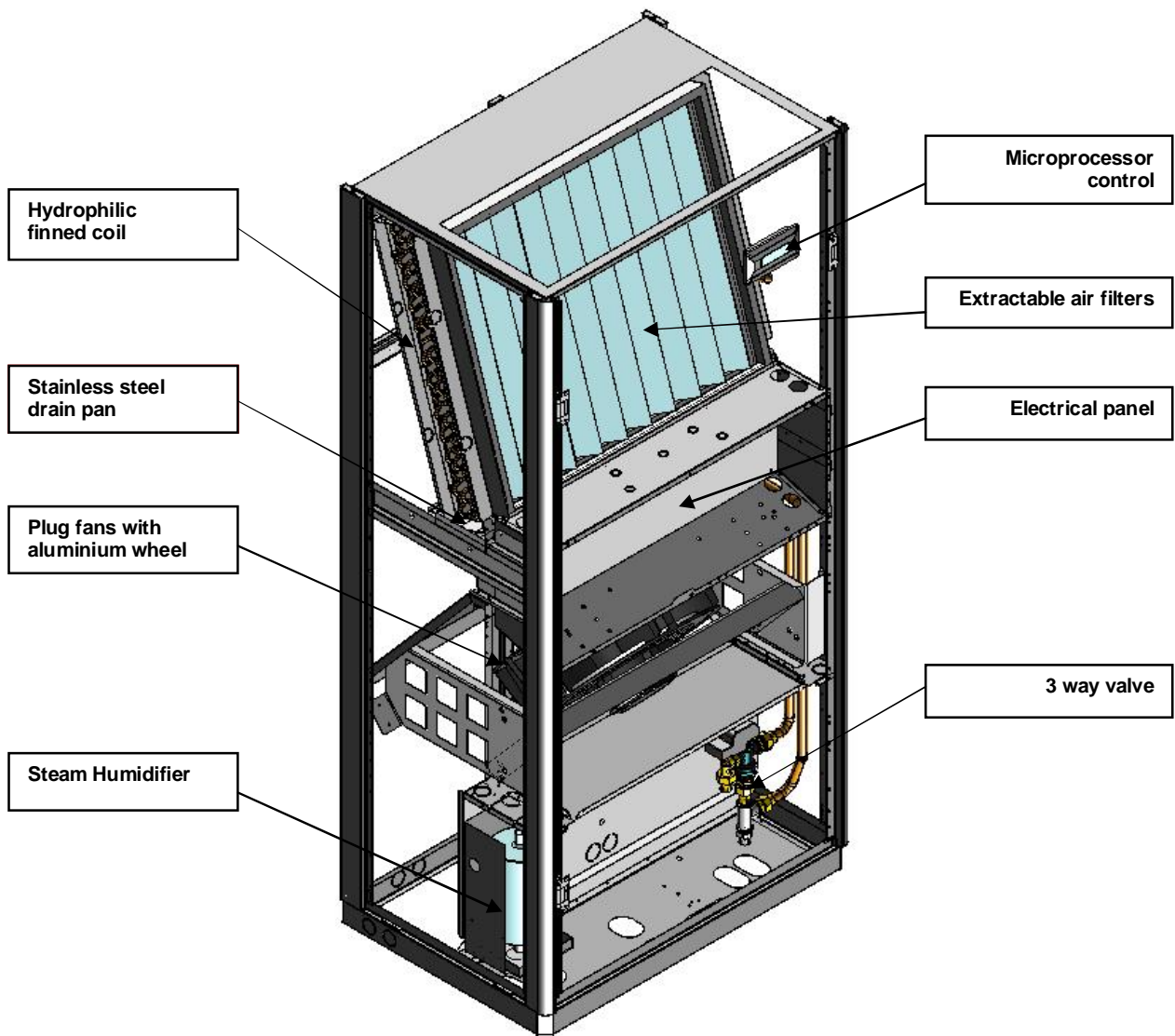
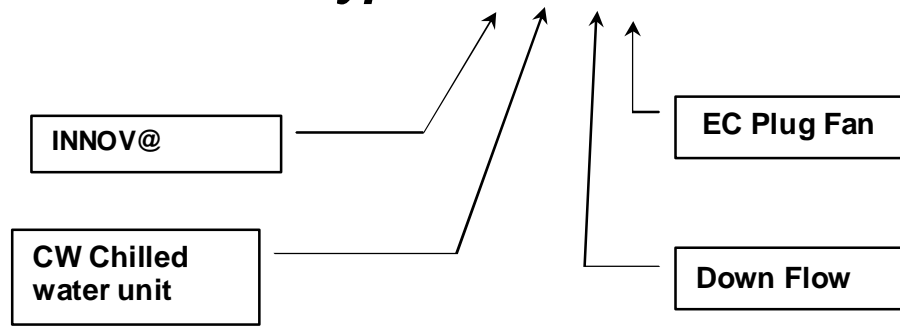

# Example of a Chilled Water Unit Type *DHCDR*:

32 – 250 kW

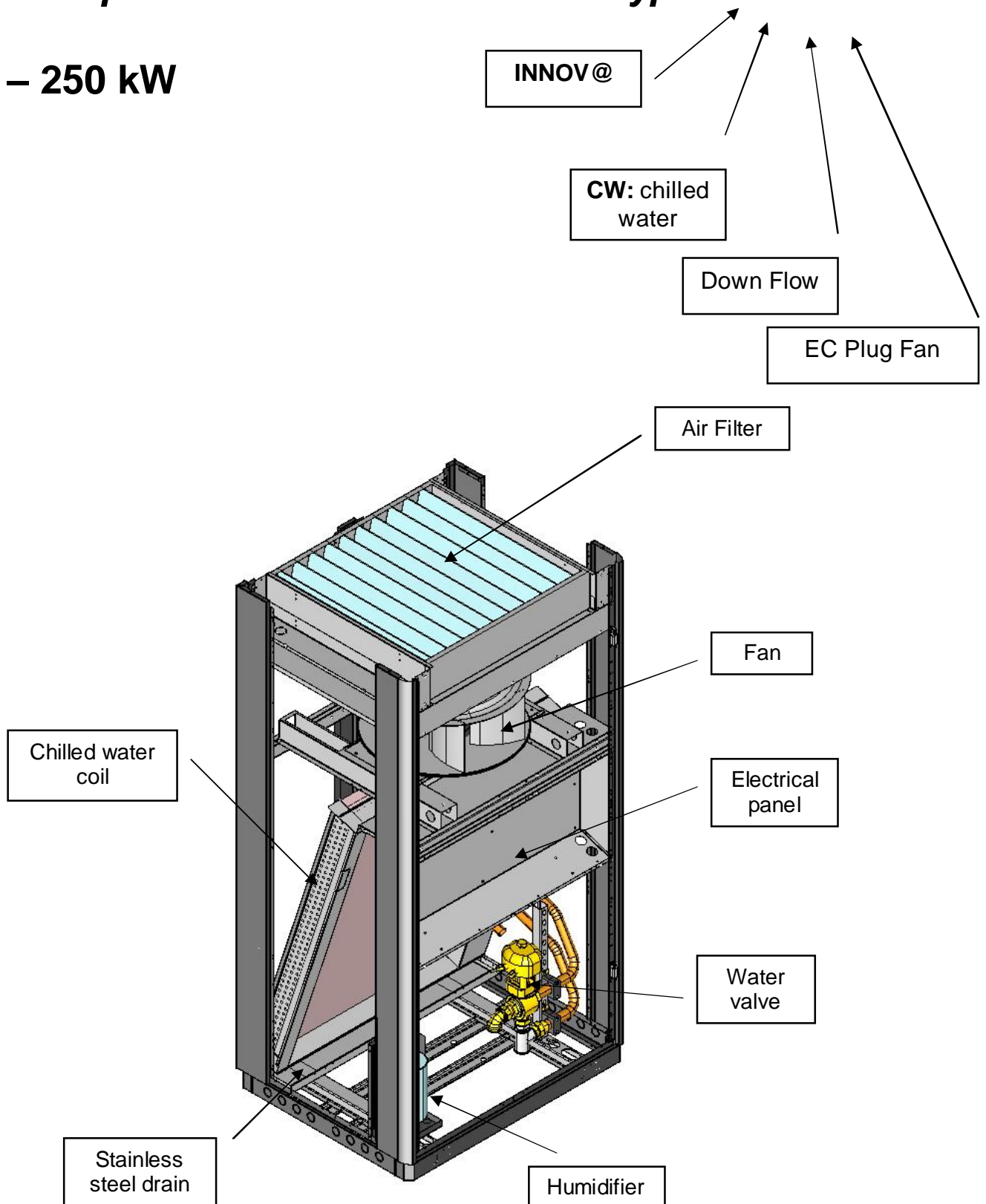



## 2. DIGIT CONFIGURATION

The INNOV@ Direct Expansion product range consists of 28 models with a cooling capacity from 6,0 to 42,5 kW in single circuit version and from 26,9 to 78,6 kW in double circuit version. The INNOV@ Chilled Water product range consist from 18 models with a cooling capacity from 7,7 to 248,5 kW. The units are available in different air flow configurations and in DX or CW version according to the configuration DIGIT shown below. For the correct choice between possible configurations the electronic configuration software shall be applied.

### DX Units : example...

DH	A	D	R	0	4	5	2	1	2	3	4	5	6	7	8	9	10	11
----	---	---	---	---	---	---	---	---	---	---	---	---	---	---	---	---	----	----

#### INNOVA series

DX Direct expansion units
A: remote air condensed units
W: water condensed units
Z: City Water Cooled
F: free cooling ("R" radial fan version only)
D: dual cooling (Water coil + DX coil remote condensed)
Q: dual cooling (Water coil + DX coil water condensed)

Air Flow
D: Downflow
U: Upflow
X: Displacement

Fans
R: Radial fan with backward curved blades

Cooling capacity
KW / 10

N° of refrigerating circuits
n°

	Configuration	
1	<b>Power supply</b>	
	400V / 3 ph + N / 50Hz	3
2	<b>Control</b>	
	Basic – Carel µAC	0
	Advanced ( with local interface ) – Carel pCO1	B
3	<b>Refrigerant</b>	
	R407C	0
	R407C with electronic expansion valve	1
	R22 (Special)	2
	R22 with electronic expansion valve (Special)	3
4	<b>Fan</b>	
	Brushless <i>EC Technology</i>	E
5	<b>Humidifier</b>	
	No	0
	Dehumidification	4
	Dehumidification + steam humidifier	5
6	<b>Electrical Heaters</b>	
	No	0
	Yes	F
7	<b>Re-Heating system</b>	
	No	0
	Hot gas coil modulating On/Off (Special)	4
	Hot gas coil modulating (only advanced control) (Special)	5
	Hot water coil with 0-10V signal activated valve (Special)	7
8	<b>Air filtration</b>	
	G3 (standard)	0
	G4	H
	G3 + clogged filter sensor	I
	G4 + clogged filter sensor	L
	F5	P
	F5 + clogged filter sensor	Q
9	<b>Condensing control 230V/1ph/50Hz</b>	
	None	0
	Mod. fan speed control with MCB (advanced) for single circuit condensers	5
	Mod. fan speed control with MCB for double circuit condensers	6
	Flooding technology refrigerant side with back pressure valve ( in „F“ version = standard)	7
	2-way water pressostatic valve for watercooled „Z“ & „Q“ version	9
10	<b>Packaging</b>	
	Standard	0
	Wooden crate with cardboard	M
	Seaworthy	N
11	<b>Special</b>	
	Standard	0
	Special	S

## CW Units : example...

DH	C	D	R
----	---	---	---

1	0	0	0
---	---	---	---

1	2	3	4	5	6	7	8	9	10	11
---	---	---	---	---	---	---	---	---	----	----

<b>INNOV@ series</b>
----------------------

<b>CW chilled water units</b>
C: basic configuration
S: slave unit without control

<b>Air Flow</b>
D: Downflow
U: Upflow
X: Displacement

<b>Fans</b>
R: Radial fan with backward curved blades

<b>Cooling capacity</b>
KW / 10

<b>N° of refrigerating circuits</b>
n°

	Configuration	
<b>1</b>	<b>Power supply</b>	
	400V / 3 ph + N / 50Hz	<b>3</b>
<b>2</b>	<b>Control</b>	
	Basic (with local interface) – Carel µAC	<b>0</b>
	Advanced ( with local interface ) – Carel pCO1	<b>B</b>
	Slave unit without microprocessor (Special)	<b>C</b>
<b>3</b>	<b>Valve</b>	
	3-way-valve with 3-point motor	<b>0</b>
	3-way-valve with 0-10V signal activated motor	<b>3</b>
<b>4</b>	<b>Fan</b>	
	Plug fan with asynchronous three-phase motors (Special)	<b>0</b>
	Plug fan with Brushless motor	<b>E</b>
<b>5</b>	<b>Humidifier</b>	
	No	<b>0</b>
	Dehumidification	<b>4</b>
	Dehumidification + Steam hum. With humidity sensor	<b>5</b>
<b>6</b>	<b>Electrical Heaters</b>	
	No	<b>0</b>
	Yes – 3 steps	<b>F</b>
<b>7</b>	<b>Re-Heating system</b>	
	No	<b>0</b>
	Hot water coil with 3 point activated valve (Special)	<b>5</b>
	Hot water coil with 0-10V signal activated valve (Special)	<b>6</b>
<b>8</b>	<b>Air filtration</b>	
	G3 (standard)	<b>0</b>
	G4	<b>H</b>
	G3 + clogged filter sensor	<b>I</b>
	G4 + clogged filter sensor	<b>L</b>
	F5	<b>P</b>
	F5 + clogged filter sensor	<b>Q</b>
<b>9</b>	<b>Condensing control</b>	
	No	<b>0</b>
<b>10</b>	<b>Packaging</b>	
	Standard	<b>0</b>
	Wooden crate with cardboard	<b>M</b>
	Seaworthy	<b>N</b>
<b>11</b>	<b>Special</b>	
	Standard	<b>0</b>
	Special	<b>S</b>

### 3. MAIN CHARACTERISTICS & FEATURES

#### INNOV@ Close Control Units

INNOV@ Close Control Units are specially designed to be installed in technological environments such as Computer rooms, laboratories and where a high precision in climate control and a 24h/day operation are requested. INNOV@ units represent the state of the art of technology and design as with all **LENNOX** products. Thanks to their characteristics, INNOV@ units can also be installed in office environments where people are working. A depth of 600 mm for the range of 5 – 27 kw allows perfect fitting with standard cabinets for EDP environments. The focus during the design was on reliability, energy efficiency and compatibility; all components, such as e-heaters, fans, compressors, valve, etc. can be easily maintained from the front of the unit, Full Frontal Accessibility. Moreover, the door/s are dismantable in just a few seconds thanks to an innovative hinge: this is a very important additional feature, specially developed to enable accessibility when units are installed in small corridors. The exclusive use of components of internationally well-known brands and a fully integrated development process (CAD+CAM, CAE) represents the highest possible quality level in efficiency, reliability, maintenance time, pre and after sales support. All DX units are available in single circuit version.

#### Frame

INNOV@ units are designed with a self-supporting frame and all components are made “in-house”, using sophisticated computer driven machines and special tools. All the sheet metal is galvanized; the external panels moreover are powder coated RAL 7016 “anthracite grey” colour, or RAL 9002 “grey white”, giving the units an image and a look such as the last generation of IT devices. The units are completely sealed, only frontal access is required. However, a side access is possible in order to reach the steam tube, the drain pan, or simply to replace a damaged side panel: all these problems are very unusual, but with INNOV@ units, it is possible to solve them, in spite of most other product on the market. The shape of the units are characterized by rounded edges of 26,5 mm radius. This individual feature is produced using special tools and it gives a new aesthetic appearance together with advantages in injury prevention. The compressor compartment is separated from the air-flow. The special internal design allows a simple dismanting of the upper part of the compartment ensuring an insuperable accessibility to all refrigerating components.

All fixing elements are made either of stainless steel or of non-corroding materials. The drain pan is made of stainless steel in order to ensure long lifetime operation without damage.

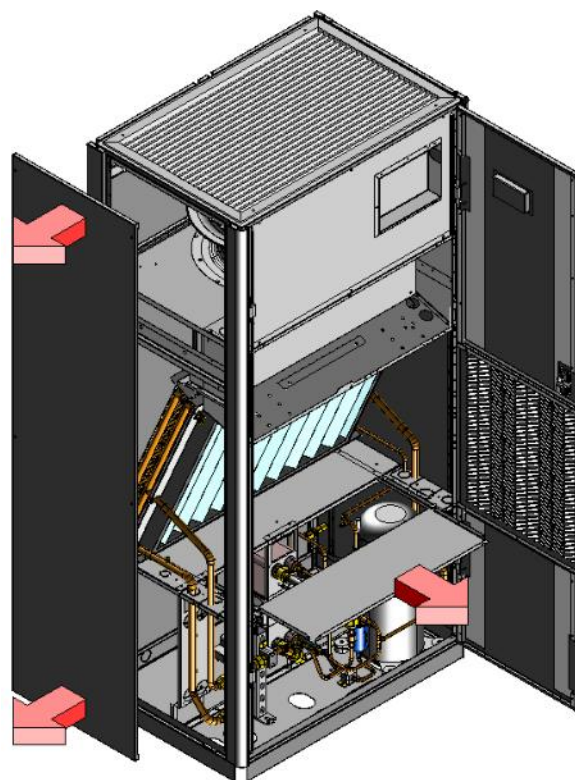

All panels are thermally insulated with a polyurethane foam class 1, according to UL 94 norms: this material, thanks to the open cells, achieves good performances in sound absorption. Sandwich panels are available as an option. They are made of synthetic fibres, laid between the external panel and a second metal sheet, to get the highest value of internal smoothness. The sound insulation is better than in standard versions, but the level of the internal reflected sound-power will increase on airflow discharge side.

#### Refrigerating circuit

The entire refrigerating circuit is assembled in LENNOX's production, including all pipe work and using only primary brand for the components. The employees involved in the welding and pipe work processes are qualified by a third part according to the CEE 97/23 PED directive: this kind of qualification for workers is not a requirement, but Lennox's policy is for the care of the product quality and of the customer's satisfaction. All DX units are in single circuit execution and are precharged with dry nitrogen for “A”, “D” or with R407C refrigerant in “W”, “F”, “Q” versions. Units for different refrigerants such as R22, R134a, and R410A are available on request.

- **Compressors:** Only primary brand scroll compressors are installed in the INNOV@ units (fig.1). The scroll compressor represents the best solution in terms of efficiency and reliability for CCU units. The internal compression ratio is very close to the typical operating condition of CCU applications, bearing the maximum in terms of COP. The perfectly balanced pressures during start-up phases are a distinct advantage for the electrical motor and its reliability, most of all in this field where start-ups are frequent.

If more cooling capacity modulation is necessary while maintaining high values of the COP, the ENERGY units with inverter compressor are suggested. Further information about this technology is available on the product documentation of **ENERGY** units.

- **Plate heat exchangers:** only AISI 304 BPHEs with low-carbon steel connections are used. The special design of the plates gives both the advantage of increasing the turbulence, reducing the fouling, and of increasing the efficiency, lowering the overall dimensions: this feature let the BPHE to be installed behind the compressor compartment, leaving more space for piping and other components.

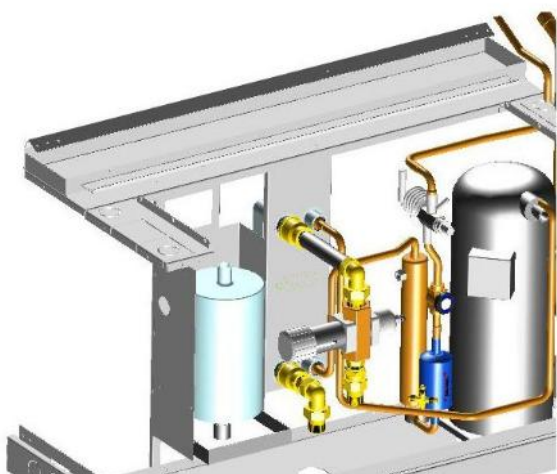

**Fig.1**

- **Finned coil heat exchanger:** All coils are made by using the 25 x 21,65 mm geometry, in combination with 9,52mm copper pipes and 0,10mm-thick aluminium fins. The expanding process, that guarantees a perfect contact between pipes and fins, is one of the most critical processes and it's 100% monitored in the whole production. The design criteria for our R&D department and our laboratories, can be summarized in 4 main points:
  - Reduction of pressure losses by using coils with a large front surface
  - Hydrophilic treatment on the fins to allow the film-condensation of the dehumidification water
  - Reduction of the vertical length to avoid thickness of water film and, at the same time, to have the possibility to deal with high air volumes and high relative humidity with no water- detaching in down-flow units.

- Special Corrugated Fins increase the heat transfer coefficient on air-side and consequently improve the SHR.

Great care has been taken over the chilled-water units by checking the behaviour of the Reynolds number inside the pipes during the modulation of the three-way valve: a transition between laminar and turbulent flow may lead to a big benefit for the heat exchange efficiency, but with loss of accuracy in T control.

In order to reduce the stocking of spare parts, as usual for all Lennox products, only one coil is used for both up- and down-flow units.

- **Remote condenser:** coils are made using the 25 x 21,65 mm geometry for the 9,52mm copper grooved pipes (5/16" for R410A refrigerant fluid) and 0,10mm-thick aluminium louvered fins. The combination of these technologies allows the maximum reduction of the internal volume and consequently a reduction of the refrigerant charge quantity. The adopted fans come only with external-rotor motor and in 4- or 6-pole execution, depending on the selected sound power level. There are already two available selections in the catalogue, but on special request, our R&D department can work further solutions out. Panels are made of galvanized precoated metal sheet and special brackets for horizontal installations are available for the whole range (as an option). For different climatic areas you can choose among three different types of condensing controls:

- None
- Modulating fan-speed control installed on-board of the CCU → down to -15°C
- Flooding technology in addition to the fan-speed control for temperatures below -15°C and down to -30°C. This last option will be supplied as a kit (including a liquid receiver, a back pressure valve, a safety valve and a protection cabinet) and needs to be installed on-site just next to the condensing unit.

- **Refrigerating components:**
  - Filter with molecular sieve and activated alumina.
  - Sight glass with humidity indication.
  - Thermostatic valve with MOP function and external equalization.
  - Electronic expansion valve for insuperable performances in middle and winter season: the pay-back of the solution in Northern-Europe countries is less than one year.
  - Liquid receiver according to the CEE 97/23 PED directive
  - HP pressostat with manual reset according to cat. IV CEE 97/23 PED.
  - LP pressostat with automatic reset and delayed time during start-ups.
  - Schrader valves for maintenance and/or control.
  - Long distance kit if needed.

## Electrical panel & components

□ Electrical panel: the electrical panel is fully integrated into the unit and is designed according to the CEE directives 72/23, 89/336 and related norms. An access to the electrical panel even with open doors is needed: with open doors the protection still remains IP 30 thanks to a transparent plastic sheet protection in front of the components. All remote signals are with low voltage 24 Vac, obtained by a safety transformer. The electrical panel has a circulation air system in order to manage the inside thermal dissipation when the unit is running. All connected loads are protected with automatic switches in addition to those, which are already provided within the compressors and fans. All 3-phase units are standard equipped with a phase sequence relay: this device checks the sequence of the phases, avoiding the start-up of the compressors in the wrong direction. With the electronic valve option (EEV), the microprocessor manages the evaporating temperature; therefore, SHR is under control also with constant air-flow.

□ Microprocessor: two different types are available:  
 - Basic – Carel  $\mu$ AC  
 - Advanced – Carel serie pCO.  
 The Lennox Software Development Team is always ready to customize the software for these controls, according to customer specifications.

The main functions are summarized in:

- Input of main parameters by means of the keyboard;
- Display of operating conditions, alarms and devices status;
- ON/OFF switching or modulating (three-way valve, humidifier) resources to keep the environment parameters constant;
- Modulation of the three-way valve for hot water re-heating (option);
- Activation / Deactivation of the solenoid valve for hot gas re-heating (option) in DX version only;
- Modulation of the humidifier capacity;
- Activation of the different steps in electrical heating (option);
- Alarm management:
  - High / Low ambient temperature;
  - High / Low pressure refrigerant circuit
  - Air Flow;
  - Dirty filters;
  - Electrical heating;
  - Humidifier general alarm;
- Management of maximum compressor starts;
- LAN connection for stand-by rotation (only with Advanced pCO).

□ Serial port / protocols

1. Advanced:
  - RS485 / Carel o Modbus® ;
  - Modem GSM + RS 232 / sms (units status advice by sms in case of alarm);
  - LonWorks® FTT-10 card / LonWorks®

- DataWeb Ethernet connection / BACnet™ o SNMP (TCP-IP)
- pCOweb RS485 connector / BACnet™
- TREND® serial card / TREND®

2. Basic:

- RS485 / Carel
- External Modbus® gateway / Modbus®

□ Display for advanced microprocessor

- pGD0 basic display:



- pGD3 Graphical Touch screen color display:



## Aeraulic section

Fans of backward-curved blades type, Plug Fans, in combination with EC motors (standard). Fans are statically and dynamically balanced ensuring a drastic reduction for noise and vibrations. This technology allows reductions of energy consumptions mainly at partial loads and allows keeping an exact air-flow apart from external conditions. The air circuit is provided with an air-flow switch that continuously checks for a fan faulty situation.



### Hydraulic Circuit

CW units are fully assembled and pressure tested in a factory final test. The three-way valves (Fig.2) are selected according to their characteristic Kvs and to the coil pressure drop, in order to give enough authority to the valve for a good water-flow control. The valve body is made of brass OT 58 and the shutter is plated in RILSAN for the maximum tightness: the Unit system is PN16. The external connections are standard supplied with 3-part quick connections to reduce the on-site working time.

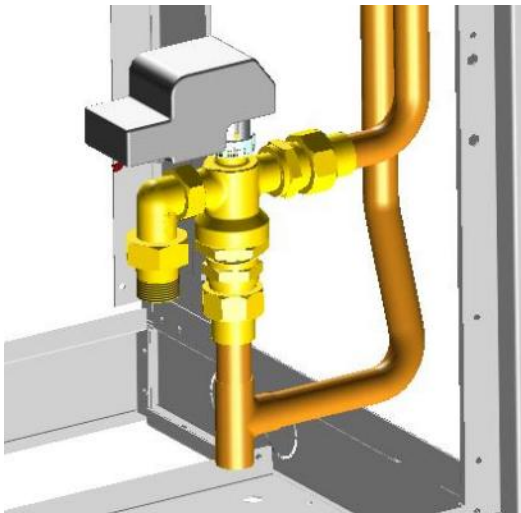

Fig. 2

```
m_select_air
+-----+
| Air flow      S2 |
| setpoint: 7000 m3/h |
+-----+
```

Operating air differential pressure and related air flow  
To see the actual air differential pressure (**Nozzle differential pressure**) and the actual air flow is necessary to enter in the Input/Output menu, and press DOWN to reach the screen .

```
m_synoptic3b
+-----+
| Analog inputs:  I2a |
| Coil temp:      000.0°C |
| Diff.press.:   000.0 Pa |
| Air flow:      00000 m3/h |
+-----+
```

### Important note

The automatic flow control is made using a PI (proportional + integral) regulation. The regulation is set with parameter to grant the stability of the system. Please take into account that the mean time to reach the stable value is 5-10 minutes.

### Automatic air flow control option

#### Air differential pressure sensor

Inside of the electrical panel is installed an air differential pressure sensor, to measure **the nozzle pressure drop dP**.

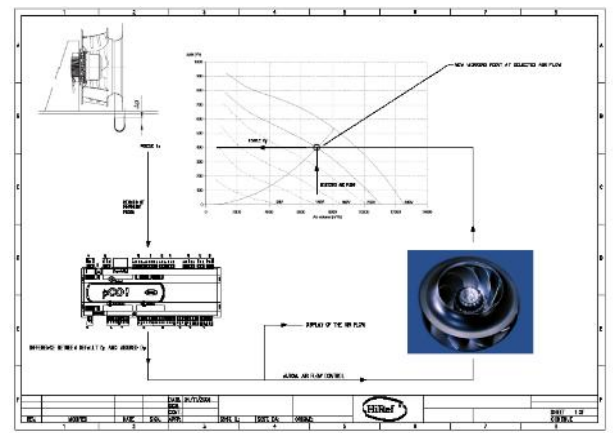
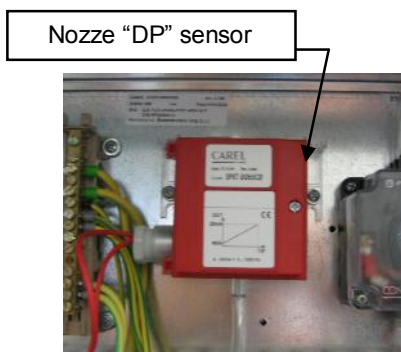

Using this value is possible to calculate the air flow and to regulate the fan speed (0-10V) to obtain the desired air flow (Air flow setpoint).

#### Air flow setpoint setting

To configure the air flow setpoint is necessary to enter in the setpoint menu and press DOWN to reach the screen S2. Then press ENTER and UP or DOWN to change the value: only step of 250 m3/h are possible.

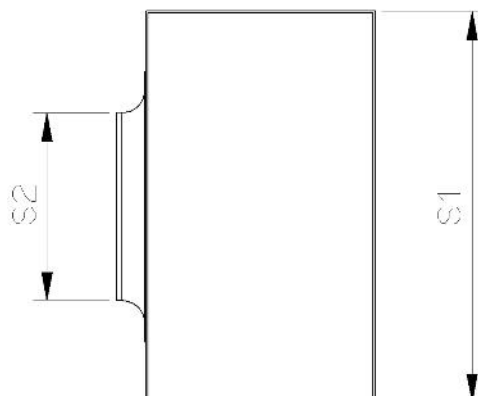

- S2 = Nozzle restricted section
- S1 = Unit's internal sec
- P = Air Pressure
- V = Air speed
- ρ = Air density

**Note:** the following calculation doesn't consider the friction and the flow coefficient of the nozzle, which are instead considered into the formulae memorized into the mP

$$\frac{p_1}{\rho} + \frac{v_1^2}{2} = \frac{p_2}{\rho} + \frac{v_2^2}{2} \quad \text{Bernoulli Principle ;}$$

$$v_1 \times S_1 = v_2 \times S_2$$

(same air flow through the two sections)

for ENERGY units the ratio S2/S1 = 0.17 so that combining both the equations, the influence of the V1 is negligible

$$\frac{p_1 - p_2}{\rho} = \frac{v_2^2}{2} \times \left( 1 - \left( \frac{S_2}{S_1} \right)^2 \right) \Rightarrow$$

$$v_2 \cong \sqrt{\frac{2 \times (p_1 - p_2)}{\rho}} \Rightarrow \text{Air Flow} = S_2 \times v_2$$

### Air Filter

The filter is positioned on the suction side just before the coil and is made of synthetic material with metallic frame. Filtration efficiency is G4, according to the Eurovent 4/5 document. To reach the filter you just have to simply open the door/s, so you can remove it. As an option, in the same frame, it is possible to install filters up to F5 class but, due to the higher pressure drops, HP fans are needed. For better filtration efficiency up to F9, an external plenum can be provided. In this case, an G3 filter will be part of the option as a prefilter; for up-flow units the high filtration plenum is positioned on the delivery side.

### Humidifier Section



5-8 kg/h

1.5-3 kg/h

The steam humidifier is fully controlled by the mP as well as all the operating parameters, like the water level, the water conductivity and the current through the electrodes. Fixing the tension, the current (and so the steam capacity) depends on the water conductivity and the water level: the algorithm that mixes all the parameters ensures the right steam production, avoiding at the same time foam grooving into the cylinder. After a certain period - depending on the water characteristics- the cylinder has to be replaced with a new one: a European average is 3 cylinders per year for full time operation.

Description of Immersed Electrode Humidifiers:

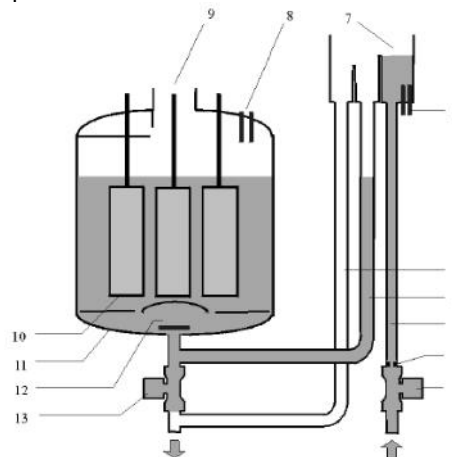

- | N. | Description                       |
|----|-----------------------------------|
| 1  | Fill solenoid valve               |
| 2  | Flow rate limiting device         |
| 3  | Supply pipe                       |
| 4  | Fill pipe                         |
| 5  | Overflow pipe                     |
| 6  | Conductivity measuring Electrodes |
| 7  | Fill tank – overflow device       |
| 8  | High level electrodes             |
| 9  | Steam outlet                      |
| 10 | Electrodes                        |
| 11 | Cylinder casing                   |
| 12 | Bottom filter                     |
| 13 | Drain solenoid valve              |

### Important water supply characteristic:

For these units there are three options:

- medium-low conductivity
- normal-high conductivity
- high conductivity

In the Appendix "A" are indicated the supply water limit values needed for the right choice among the three cylinder options.

## Humidity control

INNOV@ units can be supplied with a humidity sensor (option). For an independent control between T and r.h. it is necessary to adopt one of the re-heating possibilities (options):

- Electrical re-heating.
- Hot Water with three-way modulating valve.
- Hot gas re-heating: this solution is for DX versions only, with no additional energy consumption for the heating process. The coil design criteria allows it to have a higher heating capacity than sensible cooling capacity and to dehumidify even when there is no thermal load inside. The Hot gas re-heating can be:
  - ON / OFF
  - Modulating with a three-way valve for a precise control of the environment parameters

## Water-condensed versions

“W”, “Z”, “Q” and “F” DX water condensed units are equipped with an AISI 304 brazed plate condenser. They are fully tested and charged with POE oil and refrigerant: during the final factory test procedure, all operating parameters are measured.

Depending on the water T, but normally mandatory for “Z” versions, it is possible/necessary to add a two-way condensing control valve (Fig.3). In the case of not being able to reduce the water-flow, flooding technology is the alternative: in this case, only a refrigerant side action occurs and the water-flow remains the same.

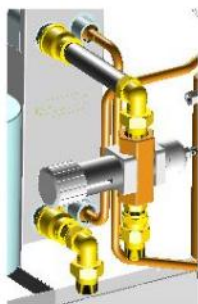

Fig. 3

The condenser is located behind the compressor compartment and is fully accessible from the front of the unit.

### Fresh air kit

The fresh air kit consists in a flexible pipe and a cartridge G3 filter. Under normal conditions, it supplies about 100 m<sup>3</sup>/h, no matter the unit size. In down-flow units, the filter is located in the fan sector. Before changing the filter, it is necessary to stop the unit and remove the sheet metal in front of the fan compartment. In up-flow units an additional booster fan is provided, to

supply nearly 80 m<sup>3</sup>/h for all models, and the relative filter is located just next to the main filter.

### Plenum Kit

A suction/delivery plenum (Fig. 4), 300mm or 500mm high, is available as an option. For down-flow units such plenums can be equipped with silencer cartridges, high efficiency filters, or, as a special option, a damper section with direct Free-Cooling configuration. In case of up-flow units, the discharge plenum can be delivered with aluminium grills for frontal air discharge.

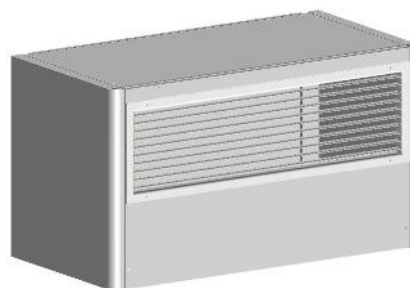

Fig.4

### Base Frames / Floor stands

Made in galvanized steel, they are available in three different sizes (300 - 500 - 800 mm), with an excursion of +/- 25mm.

### Electrical Heaters

Electrical heaters are realized for 3 steps operations and are made of aluminium with a large surface, in order to keep the lowest possible surface temperature (less than 130 °C), (Fig.5). Each heating element is provided with an independent safety thermostat. Despite the very small depth of the unit, the elements are mounted in a rail that allows their extraction from the front of all models, up and down-flow.

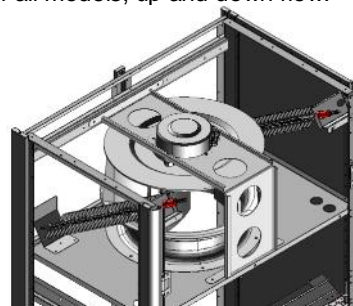

Fig. 5

Before any maintenance on the electrical heaters, disconnect the unit from the power supply and wait for 30 minutes, allowing the temperature to decrease



#### 4. APPLICATION FIELD

INNOV@ units are designed for indoor installations in technological environments, but have been tested under extreme conditions, typical example of Far and Middle East markets. The indoor temperature limits are covered from 18°C and 32°C and the r.h. limit up to 75% for the whole range. Their reliable operation practically covers all indoor conditions.

The following diagram (Fig.6) shows the application of the water-cooled DX units.

▪ Water condensed:

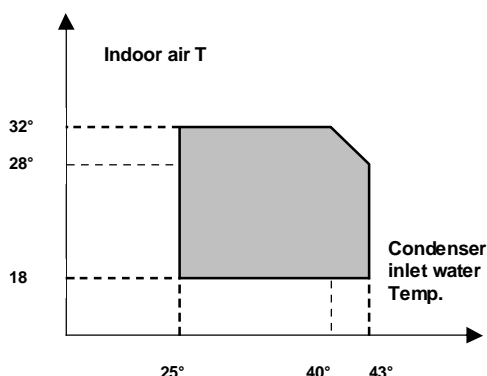

Fig. 6

Water temperatures below 25°C require a condensing control valve (option):

- ❑ Two-way modulating valve on water side: the valve is installed in the inlet piping to avoid large amounts of water flowing into the system in case of a broken pipe on refrigerant side.
- ❑ Flooding technology: this has no influence on the water flow, but a flooding of the heat exchanging surface by a constant back pressure valve and a large liquid receiver.

The next diagram (fig.7) shows the application of air-cooled DX units with Lennox condenser selection.

▪ Air condensed:

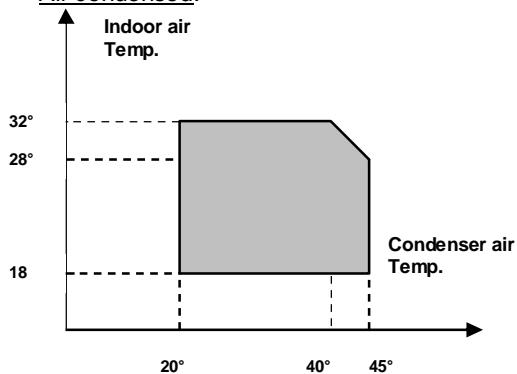

Fig. 7

If extended application ranges are needed, please contact Lennox's R&D department or your local distributor.

Applications with an external air temperature below 20°C, require a condensing control to ensure enough

pressure drops through the expansion valve. Temperatures below -15° and down to -30°C require a flooding device (Fig.8) in order to flood the condenser internal surface and get the right condensing T, even in case of strong and cold winds. This device is added as a kit, consisting in a backpressure valve, a receiver, a safety valve and assembly instructions. The installation is very simple, just close to the condensing unit at the bottom side.

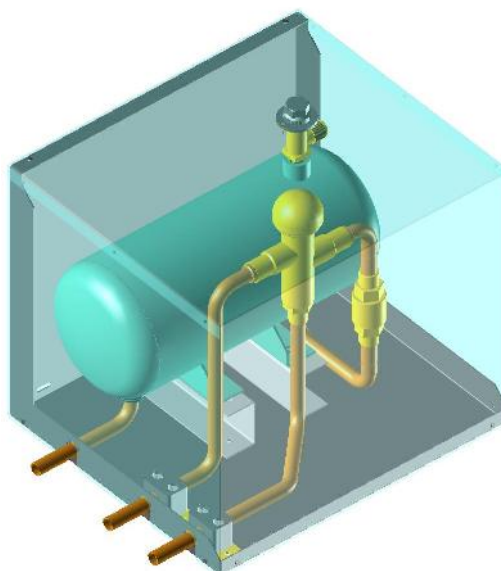

Fig.8

#### Compressors Oil Heaters

Fig.9 shows a specific property [Charles' law] of gasses: the higher the pressure, the more they get soluble in liquids; on the other hand, the lower the temperature, the less they become soluble: if the oil in the crankcase heater is kept at a constant pressure, an increase in temperature will significantly reduce the amount of refrigerant dissolved in it, thus ensuring that the desired function is maintained.

The problem of not enough lubrication occurs when the crankcase is not properly heated, most of all after a long time of standstill when, due to the suction effect of the compressor, there is an abrupt drop in pressure inside the crankcase, which results in a considerable evaporation of the refrigerant previously dissolved in the oil. With no heating elements, these circumstances would cause two problems:

- Dilution of the oil, hence insufficient lubrication
- Migration of the oil towards the cooling circuit, due to the dragging effect of the refrigerant.

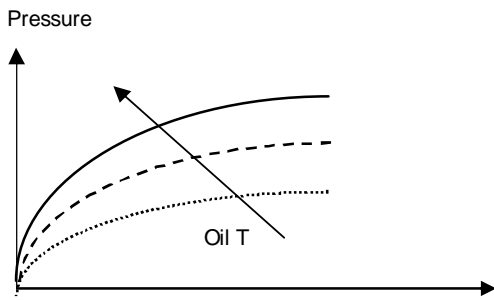

**Fig. 9** % R407C in oil

Heating elements are very important, especially when starting up for the first time; in this case it is recommended to leave them switched on for at least 12 hours before starting the compressor.

- ❑ synthetic non dangerous and non flammable refrigerant HFC R407C
- ❑ PN water side: 16 bar
- ❑ Max P refrigerant cycle HP side = 28 bar-r
- ❑ Max piping T HP side = 125° C
- ❑ Max P refrigerant cycle LP side= 22.6 bar-r (\*)
- ❑ Power supply: +/- 10% to the nominal value
- ❑ **Max storage T** = + 50 °C
- ❑ Minimum storage T = - 10 °C
- ❑ Max r.h. during storage = 85%

(\*) This value influences the maximum storage T for the units that have a closed refrigerating circuit, like "W" water cooled, "F" free cooling or "Q" Dual cooling" units.

**Application limits short table**

- ❑ operating fluid : water or e-glycol mixtures

## 5. TECHNICAL SECTION

### Thermodynamics

#### Refrigerants

INNOV@ units are charged exclusively with HFC refrigerants, which do no harm, according to specifications of the EEC regulation 2037/00. Standard units are configured for the use of R407C, a ternary mixture of R32 (23%), R125 (25%) and R134a (52%). This mixture displays a typical phase change temperature called "GLIDE" [from GLIDER = which loses height as it travels]. The glide effect is due to the fact that the three constituents have very different phase change temperatures and this leads to a sort of fractional evaporation/condensation. This means that the heat exchangers must be designed very accurately and that a careful choice of the kind of flow which occurs in them, i.e. in the opposite or same direction, must be made.

The diagram (Fig.10) illustrates this "temperature glide" as well as the beginning condensing T (dew point) and the saturated liquid/end of condensation process T (bubble point)

- Begin = DEW POINT
- End = BUBBLE POINT

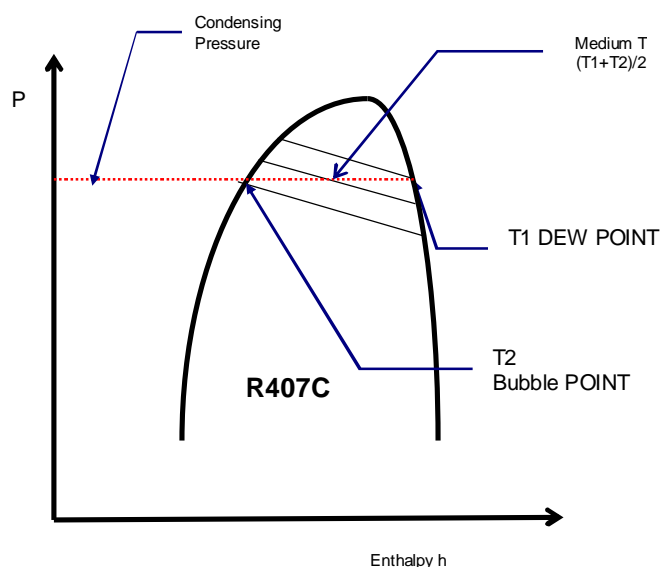

Fig. 10

#### Expansion Valves

The expansion valve is just a mass-flow regulator that ensures the right flow by checking the superheating at the evaporator outlet. The mass-flow depends mainly on the percentage of the opening and on the available Delta pressure through the valve. Mechanical valves have a very little modulating capacity and a significant Delta P through them has to be maintained to ensure the mass flow. On every Lennox product, it is possible to install innovative electronically controlled electric

expansion valves (optional), which have a much bigger

modulating capacity compared to traditional mechanical thermostatic valves. This makes it possible to operate below reduced pressure differentials during middle and winter seasons. The minimum condensing T allowed (Dew Point) is 28°C, due to the scroll compressor mechanical limits.

In this period it is possible to cut the energy consumptions even to 51 %, since the compression process occurs between two levels that are very close to each other; the limit is represented only by the intrinsic fixed compression ratio of scroll compressors. Return of investments can thus be achieved in shorter time. Lennox can support you with calculations for a different specific thermal load and outside T profiles.

The simple scheme shows how the valve is managed: a pressure transmitter reads the evaporating pressure and a T sensor measures the Refrigerant T. The mP calculates the superheating and, using special algorithms, one of which is patented by Lennox (pat. nr. BO2002A000785 ITA) drives the valve to open/close by means of a stepper motor. Only two valves cover the INNOV@ Range, giving important advantages for eventual spares. A similar technology is used to modulate hot gas bypass in units.

#### ETV scheme

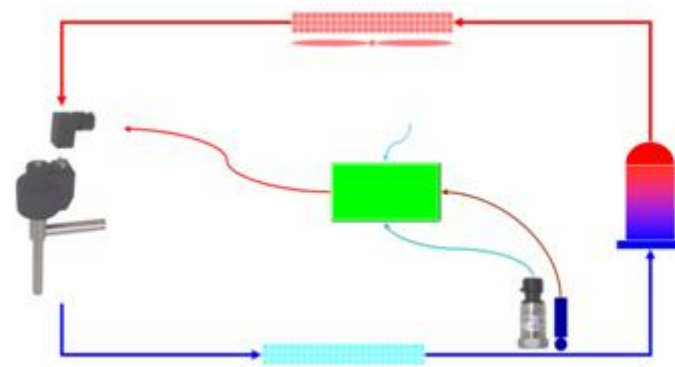

#### ETV picture



## 6. FREE COOLING

### Direct FREE COOLING

When the outdoor conditions allow it, the free cooling is the best solution to save energy. It should be considered that the external air, mixing with the internal air, will be heated without adding humidity: the lowest acceptable indoor conditions in terms of T and r.h., identifies the minimum outdoor condition at which is still possible to have free cooling.

The internal thermal load is not constant but increases during the day, and, at the same time, the external air T also raises up reducing the capacity of the free cooling. To have the maximum performance in energy saving, the peaks in cooling demands have to be phased with the peaks in free cooling capacity: the way to get this is to use the thermal inertia of appliances and structures to accumulate cool as much as possible i.e. during the night time. This is possible allowing the set-point to shift down to the limit fixed by the ETSI norms; for example, during the night, when the thermal load is low and the FC capacity is maximum, the CRAC will cool down the room(s) to the minimum allowed T (15°C) and humidity (15%). All this accumulated cool energy will help during the day, when the free cooling capacity could be lower than the internal generated load.

During the day, allowing the set point to raise up to the ETSI limits (30° in T and 70% in r.h), it is possible to avoid using the compressors as much as possible. The free cooling capacity depends directly on the T difference between the indoor environment and the external air: by allowing the Room Temperature to rise up, it is possible to extend the Freecooling operating field extending the saving period

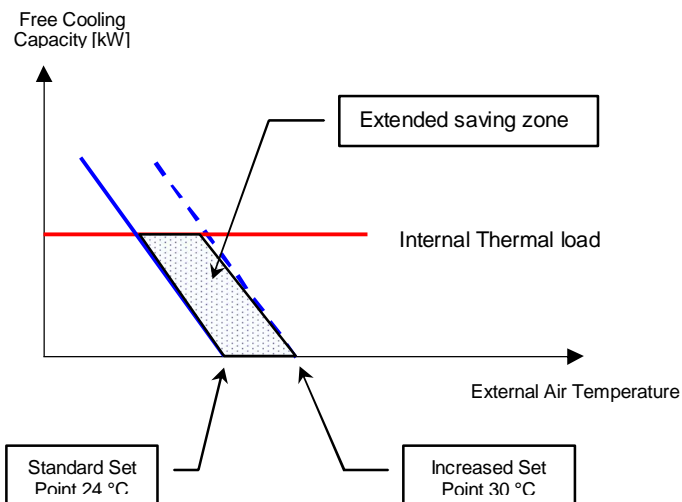
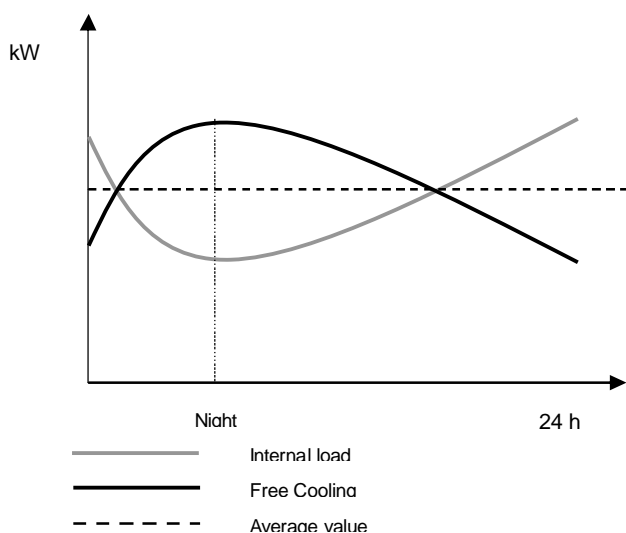

Plenum for direct free-cooling version

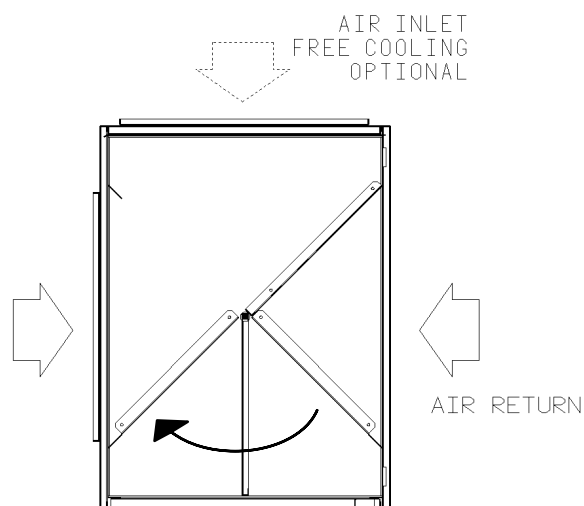

Fig. 11

In Fig. 11 is showed the scheme of the plenum installed in the direct free-cooling version. The microprocessor manages the position of the damper, allowing the external air-flow when the free-cooling conditions are reached.

**Note:** the direct free-cooling option could be select for all INNOV@ models only with down-flow version. With this solution an overpressure damper, installed on a room's wall, is necessary.

This "floating" set-point is made according parameters ( T and r.h ) fixed by the ETSI norms and in any case it is possible to modify this values using the "service password" for the microprocessor, or set the conventional modality with a fixed set point.

**Indirect FREE COOLING**

Functional scheme

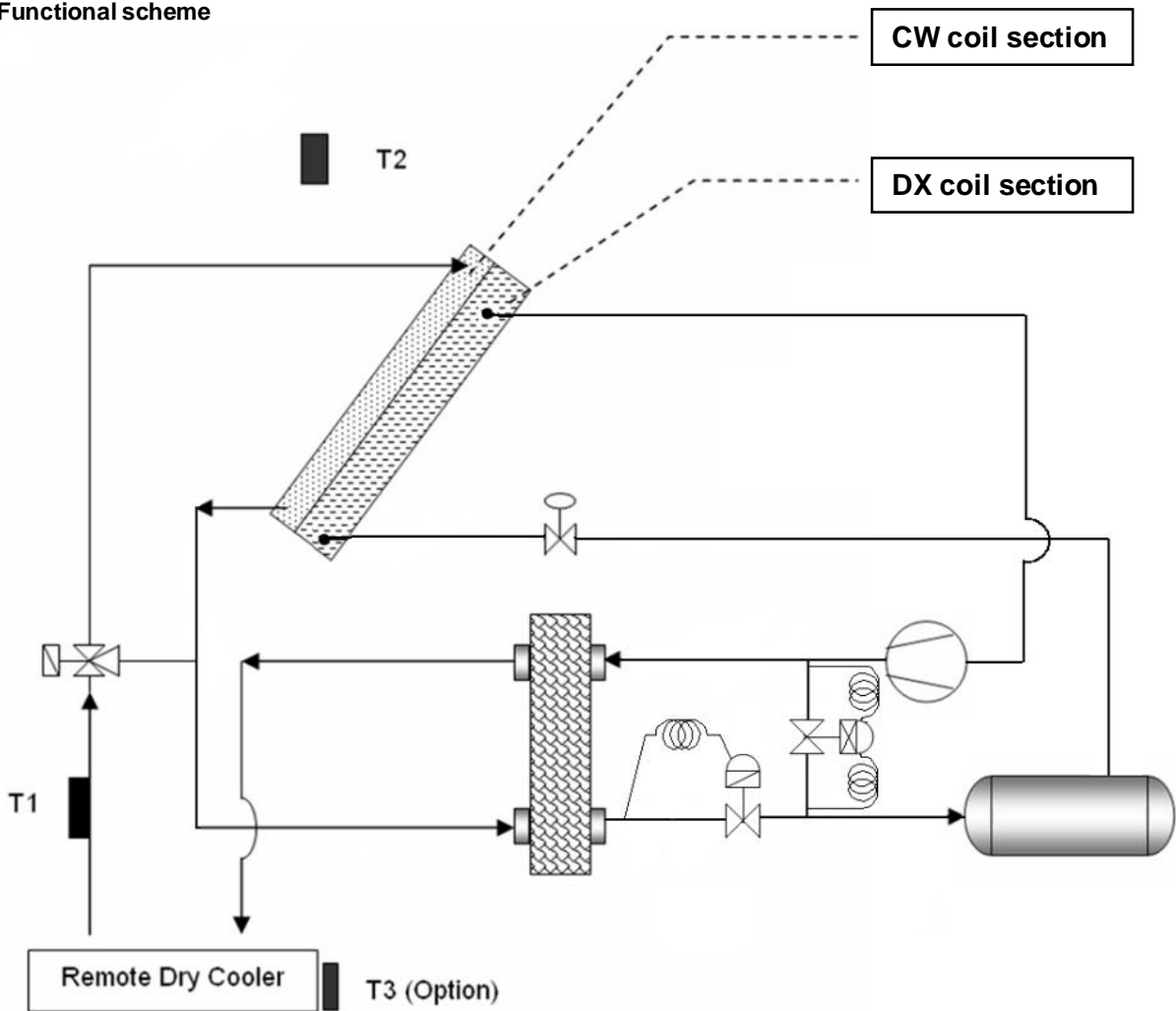

Legenda:

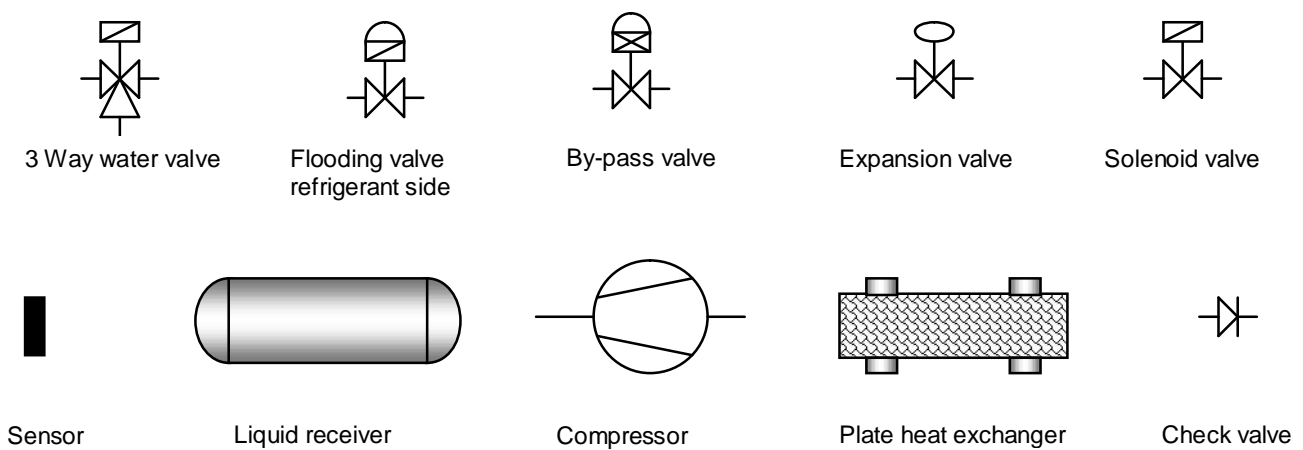

**Functionality**

Indirect free-cooling begins when the external dry cooler outlet temperature (T1) is lower than the room air temperature (T2) of a preset  $\Delta T$  (3° as default).

In this condition, the three-ways valve (see fig.12) let the cooled water flow through the CW section of the coil. If the free-cooling capacity is not enough, the compressor starts. Both circuits can work simultaneously thanks to the flooding valve system: this allows to reduce the condenser area by moving the refrigerant from the liquid receiver to the condenser, so the condensing pressure remains the same even when the water temperature is very low.

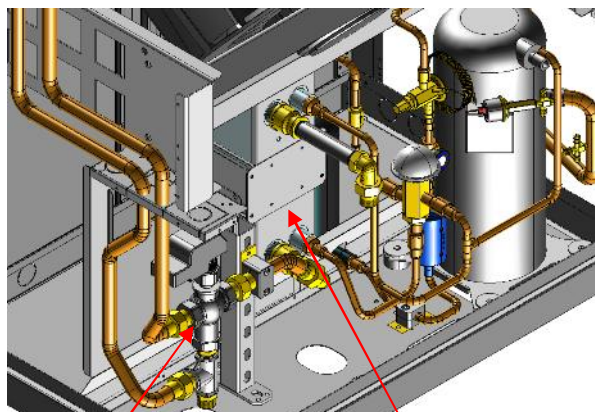

Three-way valve  
Water side

Plate condenser

**Fig.12**

The T3 sensor (optional) allows the control the dry cooler fan speed:

- If the external temperature goes below (T2 – 10°), than the fans are speeded up to the max rpm, in order to have the largest help from the free-cooling action.
- If the external air temperature is higher than (T2 – 10°) the fan speed is modulated to have an additional condensing control, and to reduce the noise level.

The T3 sensor has to be installed on site, on the dry cooler suction side and sheltered from sunshine.

**Drawing**

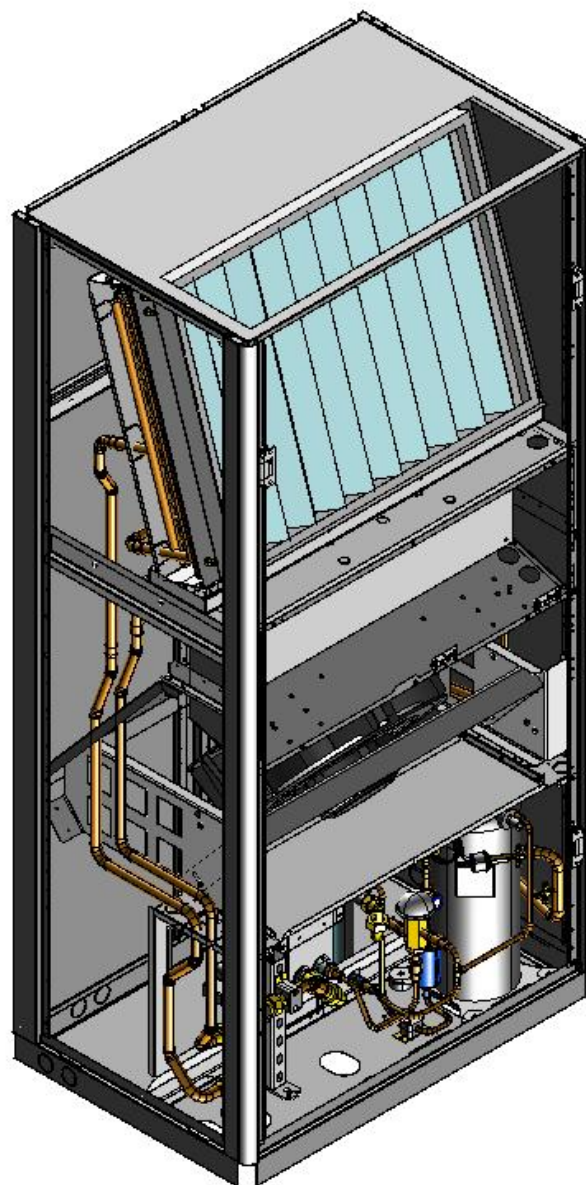



**FREE COOLING: direct Vs indirect**

Comparing these two free-cooling solutions leads to the following remarks.

Thermodynamic point of view:

With the indirect free-cooling it's possible to avoid some thermodynamic losses, which are due to the air-to-water exchange in the dry cooler and in the cooling coil, even made worse by using glycol. This means that the direct free-cooling allows more cooling capacity, at the same external air temperature, and a higher FFT (full free-cooling temperature).

Economic point of view:

Direct free-cooling is to prefer even under economic aspect. The starting investment costs, due to the structural complexity, and the working cost, due to the thermodynamic efficiency, represent a penalty in the indirect free-cooling. In this surplus cost, also the power consumptions of the water circulation pump have to be considered in indirect solution.

Air quality point of view:

Indirect free-cooling is the only way of air-conditioning when the room has to be insulated from the external air, when hard-filtering is requested (as white rooms) or if is not possible to link the unit to the external environment. Using the direct free-cooling, the specific humidity will be the same as in the outside and, for this reason, the r.h. can drop down below 20% (fig.12). For avoid this, an humidifier is needed and the related cost should be considered.

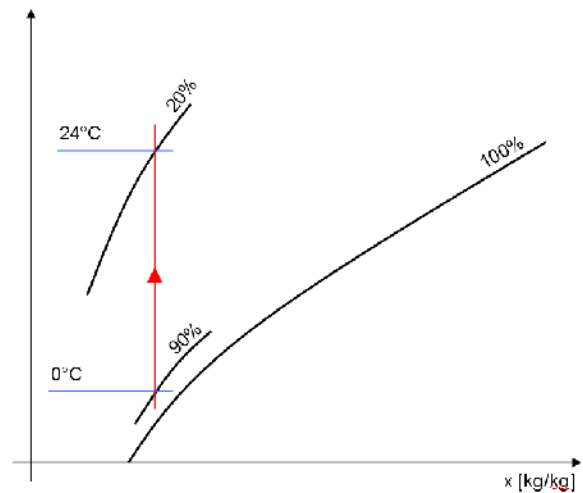
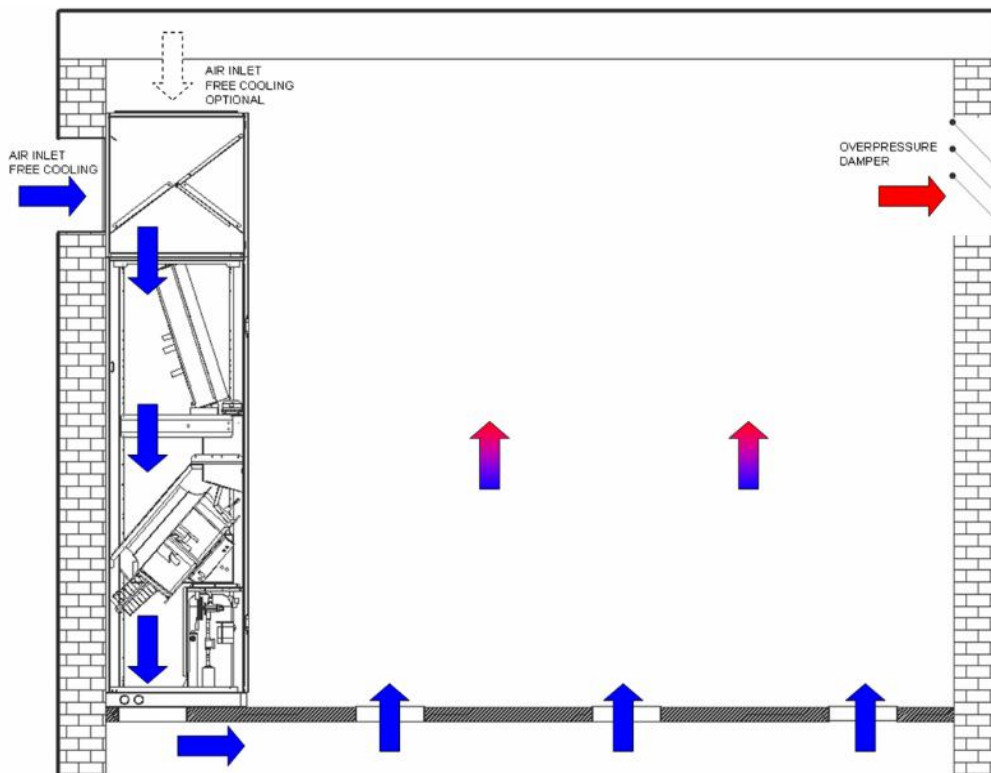

Fig.12

Overpressure damper:

When direct free-cooling, there has to be an overpressure damper to let the free-cooled air flow outside. This device will be installed on a wall and has to be designed for a  $\Delta P$  of 30 Pa in the nominal air-flow conditions.

The direct free-cooling option is available only for the down-flow configuration.



## 7. RE-HEATING SYSTEMS AND CAPACITY CONTROL

INNOV@ units different options can be chosen in order to control temperature and humidity. Below functionality schemes and function of different options:

### Hot Gas Re-heating Coil ON/OFF

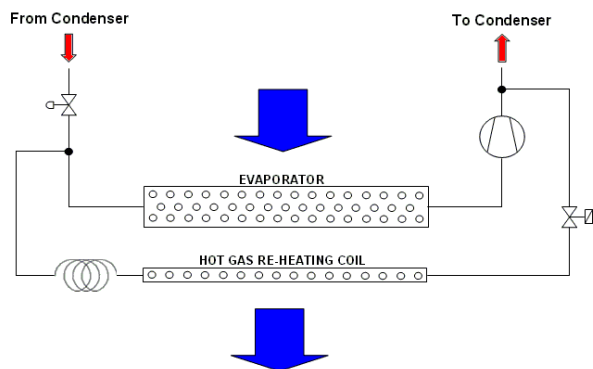

In the hot gas re-heating coil ON/OFF option a 2-way valve with no modulation (ON/OFF) is used. The function is reheating in dehumidification, but there can be no temperature close control and additional heating. The hot gas re-heating coil is designed to kill up to 90% of the total sensible cooling capacity provided by the refrigerating circuit.

### Hot Gas Re-heating Coil PRECISE

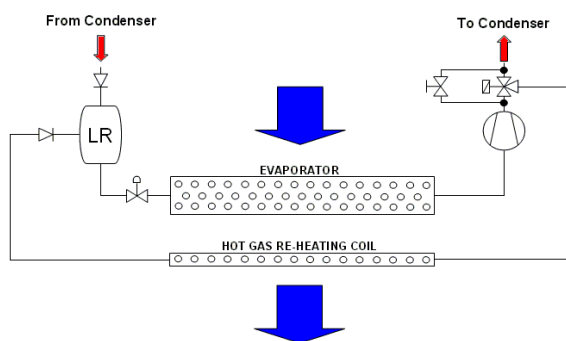

In the hot gas re-heating coil PRECISE option a 3-way valve modulates the hot gas flow through the re-heating coil. The 3-way valve cannot completely by-pass the whole hot-gas mass flow into the re-heating coil; this to avoid HP alarms to switch on. The functions are reheating in dehumidification, precise temperature control, but not additional heating. The hot gas re-heating coil is designed to kill up to 90% of the total sensible cooling capacity provided by the refrigerating circuit.

### Hot Gas BY-PASS

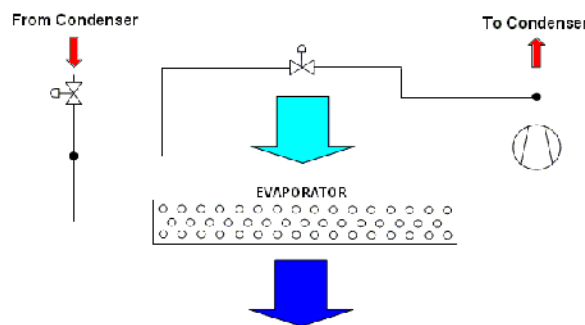

In the hot gas BY-PASS option a modulating valve manages the hot gas flow into the evaporating coil. The aim is to control the cooling capacity from 30% to 100%.

### Hot Water Re-heating Coil

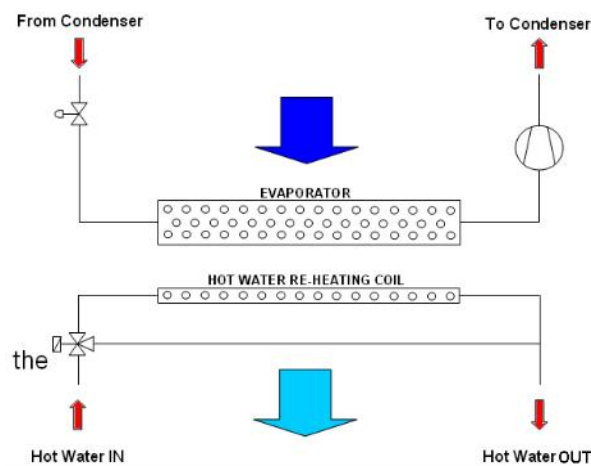

With this option, a hot water connection is needed. In the hot water re-heating coil option, a 3-way valve modulates the hot water flow through the re-heating coil. The function is reheating in dehumidification, but not temperature close control. Together with the next solution (electrical heaters), this is the only way of heating while the compressor is kept off. The heating capacity of the hot water re-heating coil depends on the inlet water conditions available.



**Electrical heaters**

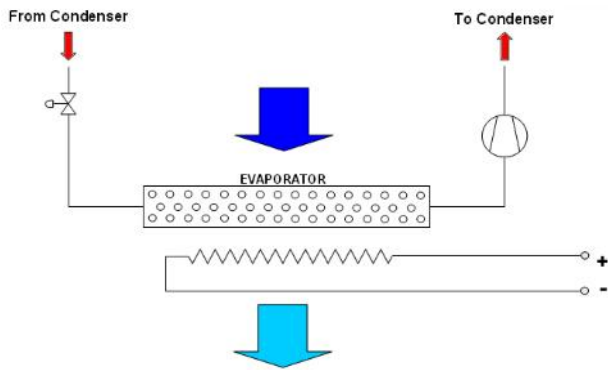

The function of the electrical heaters is reheating in dehumidification and heating while the compressor is off, but there can be no temperature close control. The heating capacity of the electrical heaters is 1.6 kW: only one module can be installed in Frame1 units and two in Frame2. The electrical heaters heating elements are in aluminium, with a wide surface that allow low temperature during heating phases.

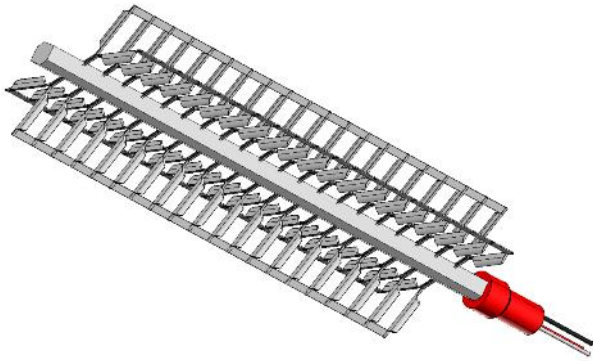

## 8. TECHNICAL DATA

### a. DX UNITS – AIR COOLED

INNOV@	DHADR/DHAUR	0060	0080	0100	0110
Air Flow	[ m3/h ]	1.785	2.150	3.530	3.530
<b>Compressor</b>					
Type		Scroll	Scroll	Scroll	Scroll
Cooling Capacity @ 24°C 50% UR – Condensing temperature 45°C (Dew point)	[ kW ]	6	8	9,9	11
Power consumption	[ kW ]	1,5	1,9	2,3	2,6
Nominal current	[ A ]	2,8	3,6	4,4	5,1
FLA	[ A ]	5	6	6	7
LRA	[ A ]	24	32	40	46
POE Oil charge	[ l ]	1	1	1,1	1,1
<b>Finned Coil Evaporator</b>					
Front surface	[m2]	0,27	0,27	0,45	0,45
Geometry		25 x 21,65	25 x 21,65	25 x 21,65	25 x 21,65
Rows	[ - ]	3	4	3	3
Type of fins	[ - ]	Hydrophilic	Hydrophilic	Hydrophilic	Hydrophilic
Fin pitch	[ mm ]	1,8	1,8	1,8	1,8
SHR	[ - ]	1	0,96	1	1
<b>Indoor Fan</b>					
Type		EC Plug Fan	EC Plug Fan	EC Plug Fan	EC Plug Fan
Power supply	[ V/Ph/Hz ]	400/3/50	400/3/50	400/3/50	400/3/50
Number of fans		1	1	1	1
Fans absorbed current	[ A ]	0,24	0,33	0,51	0,51
Fans absorbed power	[W]	151	203	315	315
AESP	[Pa]	30	30	30	30
AESP @ max fan speed	[Pa]	557	505	477	477
<b>Air Filter</b>					
Filtration		G3	G3	G3	G3
Overall surface	[m2]	2,2	2,2	3,6	3,6
Fire resistance class		1	1	1	1
<b>Electrical heaters</b>					
Total heating capacity	[kW]	1,6	1,6	3,2	3,2
N° of heaters		1	1	2	2
Material	[ - ]	Aluminium	Aluminium	Aluminium	Aluminium
<b>Hot Gas Reheating Coil</b>					
Heating capacity	[ kW ]	5,1	5,5	9	9
Front surface	[m2]	0,22	0,22	0,37	0,37
<b>Hot Water Reheating Coil</b>					
Heating capacity @ water 45/40° C	[ kW ]	4,2	4,6	7,8	7,8
Front surface	[m2]	0,22	0,22	0,37	0,37
Water Flow	[m3/h]	0,73	0,792	1,365	1,365
Water side pressure drop	[ kPa ]	8,2	9,4	15,5	15,5
Water valve pressure drop	[ kPa ]	3,3	3,9	4,4	4,4
Internal volume	[ dm3 ]	0,9	0,9	1,3	1,3
<b>Humidifier</b>					
Max theoretical capacity	[ kg/h ]	2,8	3,17	4,45	5,22
Effective capacity	[ kg/h ]	3	3	3	3
Absorbed power	[ kW ]	2,25	2,25	2,25	2,25
<b>Frame</b>					
H	[mm]	1.875	1.875	1.875	1.875
L	[mm]	600	600	900	900
D	[mm]	600	600	600	600
Weight	[kg]	150	157	195	210

**DX UNITS – AIR COOLED**

INNOV@	DHADR/DHAUR	0130	0160	0190	0205
Air Flow	[ m3/h ]	3.700	5.100	5.100	5.100
<b>Compressor</b>					
Type		Scroll	Scroll	Scroll	Scroll
Cooling Capacity @ 24°C 50% UR – Condensing temperature 45°C (Dew point)	[ kW ]	13	17,2	19,9	22
Power consumption	[ kW ]	3,2	4,2	4,9	5,5
Nominal current	[ A ]	6,2	8	8,7	10,5
FLA	[ A ]	10	13	13	15
LRA	[ A ]	50	66	74	101
POE Oil charge	[ l ]	1,36	1,65	1,65	1,65
<b>Finned Coil Evaporator</b>					
Front surface	[m2]	0,45	0,53	0,53	0,53
Geometry		25 x 21,65	25 x 21,65	25 x 21,65	25 x 21,65
Rows	[ - ]	4	4	5	5
Type of fins	[ - ]	Hydrophilic	Hydrophilic	Hydrophilic	Hydrophilic
Fin pitch	[ mm ]	1,8	1,8	1,8	1,8
SHR	[ - ]	0,98	0,99	0,94	0,92
<b>Indoor Fan</b>					
Type		EC Plug Fan	EC Plug Fan	EC Plug Fan	EC Plug Fan
Power supply	[ V/Ph/Hz ]	400/3/50	400/3/50	400/3/50	400/3/50
Number of fans		1	1	1	1
Fans absorbed current	[ A ]	0,47	1,05	1,19	1,19
Fans absorbed power	[W]	291	652	743	743
AESP	[Pa]	30	30	30	30
AESP @ max fan speed	[Pa]	453	174	144	144
<b>Air Filter</b>					
Filtration		G3	G3	G3	G3
Overall surface	[m2]	3,6	5	5	5
Fire resistance class		1	1	1	1
<b>Electrical heaters</b>					
Total heating capacity	[kW]	3,2	3,2	3,2	3,2
N° of heaters		2	2	2	2
Material	[ - ]	Aluminium	Aluminium	Aluminium	Aluminium
<b>Hot Gas Reheating Coil</b>					
Heating capacity	[ kW ]	9,1	10,3	10,3	10,3
Front surface	[m2]	0,37	0,37	0,37	0,37
<b>Hot Water Reheating Coil</b>					
Heating capacity @ water 45/40° C	[ kW ]	8	9,2	9,2	9,2
Front surface	[m2]	0,37	0,37	0,37	0,37
Water Flow	[m3/h]	1,393	1,595	1,595	1,595
Water side pressure drop	[ kPa ]	16,1	20,3	20,3	20,3
Water valve pressure drop	[ kPa ]	4,6	6	6	6
Internal volume	[ dm3 ]	1,3	1,3	1,3	1,3
<b>Humidifier</b>					
Max theoretical capacity	[ kg/h ]	5,01	10,09	6,9	6,5
Effective capacity	[ kg/h ]	3	3	3	3
Absorbed power	[ kW ]	2,25	2,25	2,25	2,25
<b>Frame</b>					
H	[mm]	1.875	1.875	1.875	1.875
L	[mm]	900	900	900	900
D	[mm]	600	600	600	600
Weight	[kg]	230	245	255	257

**DX UNITS – AIR COOLED**

INNOV@	DHADR/DHAUR	0201	0251	0281	0311	0401
Air Flow	[ m <sup>3</sup> /h ]	6800	6800	7280	7280	12950
<b>Compressor</b>						
Type		Scroll	Scroll	Scroll	Scroll	Scroll
Cooling Capacity @ 24°C 50% R.H. – external air temperature 35°C	[ kW ]	22,92	23,74	27,68	31,56	42,53
Power consumption	[ kW ]	5,33	5,65	7,13	7,87	10,71
Nominal Current	[ A ]	10,14	10,75	13,42	15,14	19,05
FLA	[ A ]	17	17	20	29	29
LRA	[ A ]	86	98	130	130	135
POE Oil charge	[l]	3.25	3.25	3.25	4.25	3.3
<b>Finned coil evaporator</b>						
Front Surface	[m <sup>2</sup> ]	0,68	0,68	0,90	0,90	1,31
Geometry		25 x 22	25 x 22	25 x 22	25 x 22	25 x 22
Rows	[ - ]	5	5	5	5	4
Type of fins	[ - ]	Hydrophilic	Hydrophilic	Hydrophilic	Hydrophilic	Hydrophilic
Fin pitch	[ mm ]	1,8	1,8			1,8
SHR	[ - ]	0,93	0,91	0,89	0,83	0,90
<b>Indoor fan</b>						
Type		Radial-EC	Radial-EC	Radial-EC	Radial-EC	Radial-EC
Power supply	[V-ph-Hz]	400/3/50	400/3/50	400/3/50	400/3/50	400/3/50
Number of fans		1	1	1	1	2
Fans absorbed current	[ A ]	1,61	1,61	2,01	2,01	1,53
Fans absorbed power	[W]	1007	1007	1252	1252	956
AESP	[Pa]	<b>30</b>	<b>30</b>	<b>30</b>	<b>30</b>	<b>30</b>
AESP (maximum speed)	[Pa]	367,5	367,5	298,4	298,4	382,2
<b>Air Filter</b>						
Filtration		<b>G4</b>	<b>G4</b>	<b>G4</b>	<b>G4</b>	<b>G4</b>
Overall surface	[m <sup>2</sup> ]	1.44	1.44	1.44	2.92	2.92
Fire resistance class		1	1	1	1	1
<b>Electrical heaters</b>						
Total Heating Capacity	[kW]	6,4	6,4	6,4	6,4	9,6
N° of heaters		4	4	4	4	6
Material	[ - ]	Alluminium	Alluminium	Alluminium	Alluminium	Alluminium
<b>Hot gas Reheating Coil</b>						
Heating capacity	[ kW ]	16,50	16,70	-	-	37,20
Front Surface	[m <sup>2</sup> ]	0,68	0,68	0,90	0,90	1,31
<b>Hot Water reheating coil</b>						
Heating capacity @ 45/40° water T	[ kW ]	14,50	14,70	-	-	29,60
Front Surface	[m <sup>2</sup> ]	0,68	0,68	0,90	0,90	1,31
Water flow	[l/h]	2494	2528	-	-	5091
Water side pressure drop	[ kPa ]	13,00	13,00	-	-	42,00
Water valve pressure drop	[ kPa ]	14,72	15,13	-	-	10,13
Internal volume	[ dm <sup>3</sup> ]	1,6	1,6	-	-	3,2
<b>Humidifier</b>						
Max theoretical capacity	[ kg/h ]	3	3	3	3	8
Effective capacity	[ kg/h ]	10,43	10,34	9,93	9,53	10,80
Absorbed power	[ kW ]	2,25	2,25	2,25	2,25	6
<b>Frame</b>						
H	[mm]	1998	1998	1998	1998	1998
L	[mm]	1010	1010	1270	1270	1760
D	[mm]	795	795	795	795	795
Weight	[ kg ]	375	385	490	505	595

**DX UNITS – AIR COOLED**

INNOV@	DHADR/DHAUR	0201	0251	0281	0311	0401
Air Flow	[ m3/h ]	6800	6800	7280	7280	12950
<b>Compressor</b>						
Type		Scroll	Scroll	Scroll	Scroll	Scroll
Cooling Capacity @ 24°C 50% R.H. - external air temperature 35°C	[ kW ]	22,92	23,74	27,68	31,56	42,53
Power consumption	[ kW ]	5,33	5,65	7,13	7,87	10,71
Nominal Current	[ A ]	10,14	10,75	13,42	15,14	19,05
FLA	[ A ]	17	17	20	29	29
LRA	[ A ]	86	98	130	130	135
POE Oil charge	[ l ]	3.25	3.25	3.25	4.25	3.3
<b>Finned coil evaporator</b>						
Front Surface	[m2]	0,68	0,68	0,90	0,90	1,31
Geometry		25 x 22	25 x 22	25 x 22	25 x 22	25 x 22
Rows	[ - ]	5	5	5	5	4
Type of fins	[ - ]	Hydrophilic	Hydrophilic	Hydrophilic	Hydrophilic	Hydrophilic
Fin pitch	[ mm ]	1,8	1,8			1,8
SHR	[ - ]	0,93	0,91	0,89	0,83	0,90
<b>Indoor fan</b>						
Type		Radial-EC	Radial-EC	Radial-EC	Radial-EC	Radial-EC
Power supply	[V-ph-Hz]	400/3/50	400/3/50	400/3/50	400/3/50	400/3/50
Number of fans		1	1	1	1	2
Fans absorbed current	[ A ]	1,61	1,61	2,01	2,01	1,53
Fans absorbed power	[W]	1007	1007	1252	1252	956
AESP	[Pa]	<b>30</b>	<b>30</b>	<b>30</b>	<b>30</b>	<b>30</b>
AESP (maximum speed)	[Pa]	367,5	367,5	298,4	298,4	382,2
<b>Air Filter</b>						
Filtration		<b>G4</b>	<b>G4</b>	<b>G4</b>	<b>G4</b>	<b>G4</b>
Overall surface	[m2]	1,44	1,44	1,44	2,92	2,92
Fire resistance class		1	1	1	1	1
<b>Electrical heaters</b>						
Total Heating Capacity	[kW]	6,4	6,4	6,4	6,4	9,6
N° of heaters		4	4	4	4	6
Material	[ - ]	Alluminium	Alluminium	Alluminium	Alluminium	Alluminium
<b>Hot gas Reheating Coil</b>						
Heating capacity	[ kW ]	16,50	16,70	-	-	37,20
Front Surface	[m2]	0,68	0,68	0,90	0,90	1,31
<b>Hot Water reheating coil</b>						
Heating capacity @ 45/40° water T	[ kW ]	14,50	14,70	-	-	29,60
Front Surface	[m2]	0,68	0,68	0,90	0,90	1,31
Water flow	[l/h]	2494	2528	-	-	5091
Water side pressure drop	[ kPa ]	13,00	13,00	-	-	42,00
Water valve pressure drop	[ kPa ]	14,72	15,13	-	-	10,13
Internal volume	[ dm3 ]	1,6	1,6	-	-	3,2
<b>Humidifier</b>						
Max theoretical capacity	[ kg/h ]	3	3	3	3	8
Effective capacity	[ kg/h ]	10,43	10,34	9,93	9,53	10,80
Absorbed power	[ kW ]	2,25	2,25	2,25	2,25	6
<b>Frame</b>						
H	[mm]	1998	1998	1998	1998	1998
L	[mm]	1010	1010	1270	1270	1760
D	[mm]	795	795	795	795	795
Weight	[ kg ]	375	385	490	505	595

**DX UNITS – AIR COOLED**

INNOV@	DHADR/DHAUR	0272	0302	0362	0422	0452
<b>Air Flow</b>	[ m3/h ]	12950	12950	12950	12950	12950
<b>Compressor</b>						
<b>Type</b>		Scroll	Scroll	Scroll	Scroll	Scroll
<b>Cooling Capacity @ 24°C 50% R.H. – external air temperature 35°C</b>	[ kW ]	26.9	31.9	35.9	41.9	44.3
<b>Power consumption</b>	[ kW ]	6.8	8.5	9.8	11.6	12.2
<b>Nominal Current</b>	[ A ]	12.2	16.2	17.4	21.4	22.6
<b>FLA (1 compressor)</b>	[ A ]	10	13	14	17	17
<b>LRA (1 compressor)</b>	[ A ]	50	66	74	86	98
<b>POE Oil charge</b>	[l]	1.36	1.36	1.65	3.25	3.25
<b>Finned coil evaporator</b>						
<b>Front Surface</b>	[m2]	1.3	1.3	1.3	1.3	1.3
<b>Geometry</b>		25 x 21,6	25 x 21,6	25 x 21,6	25 x 21,6	25 x 21,6
<b>Rows</b>	[ - ]	3	3	3	4	4
<b>Type of fins</b>	[ - ]	Hydrophilic	Hydrophilic	Hydrophilic	Hydrophilic	Hydrophilic
<b>Fin pitch</b>	[ mm ]	1.8	1.8	1.8	1.8	1.8
<b>SHR</b>	[ - ]	1.00	0.99	0.98	0.97	0.98
<b>Indoor fan</b>						
<b>Type</b>		EC Plug Fan	EC Plug Fan	EC Plug Fan	EC Plug Fan	EC Plug Fan
<b>Power supply</b>	[V-ph-Hz]	400/3/50	400/3/50	400/3/50	400/3/50	400/3/50
<b>Number of fans</b>		2	2	2	2	2
<b>Fans absorbed current</b>	[ A ]	4.3	4.3	4.3	4.4	4.4
<b>Fans absorbed power</b>	[W]	2500	2500	2500	2595	2600
<b>AESP nominal fan speed</b>	[ Pa ]	30	30	30	30	30
<b>AESP (maximum speed)</b>	[Pa]	425	425	425	355	355
<b>Air Filter</b>						
<b>Filtration</b>		G4	G4	G4	G4	G4
<b>Overall surface</b>	[m2]	2.92	2.92	2.92	2.92	2.92
<b>Fire resistance class</b>		1	1	1	1	1
<b>Electrical heaters</b>						
<b>Total Heating Capacity</b>	[kW]	9.6	9.6	9.6	9.6	9.6
<b>N° of heaters</b>		3	3	3	3	3
<b>Material</b>	[ - ]	Aluminium	Aluminium	Aluminium	Aluminium	Aluminium
<b>Hot gas Reheating Coil</b>						
<b>Heating capacity</b>	[ kW]	34.1	33.7	33.7	41.6	42.3
<b>Front Surface</b>	[m2]	1.05	1.05	1.05	1.05	1.05
<b>Hot Water reheating coil</b>						
<b>Heating capacity @ 45/40° water T</b>	[ kW]	28,7	29,2	30,0	30,0	30,0
<b>Front Surface</b>	[m2]	1.05	1.05	1.05	1.05	1.05
<b>Water flow</b>	[m3/h]	4.936	5.021	5.159	5.159	5.159
<b>Water side pressure drop</b>	[ kPa ]	39.6	41.0	42.0	42.0	42.0
<b>Water valve pressure drop</b>	[ kPa ]	7.69	8.42	9.19	10.13	10.61
<b>Internal volume</b>	[ dm3]	2.786	2.786	2.786	2.786	2.786
<b>Humidifier</b>						
<b>Max theoretical capacity</b>	[ kg/h ]	26.00	21.66	22.41	21.09	23.20
<b>Effective capacity</b>	[ kg/h ]	8	8	8	8	8
<b>Absorbed power</b>	[ kW]	6	6	6	6	6
<b>Frame</b>						
<b>H</b>	[mm]	1998	1998	1998	1998	1998
<b>L</b>	[mm]	1750	1750	1750	1750	1750
<b>D</b>	[mm]	795	795	795	795	795
<b>Weight</b>	[ kg ]	565	580	590	605	615

**DX UNITS – AIR COOLED**

INNOV@	DHADR/DHAUR	0532	0592	0602	0692	0762
Air Flow	[ m <sup>3</sup> /h ]	14150	14150	19415	19415	19415
<b>Compressor</b>						
Type		Scroll	Scroll	Scroll	Scroll	Scroll
Cooling Capacity @ 24°C 50% R.H. – external air temperature 35°C	[ kW ]	53,94	59,08	64,44	71,03	78,59
Power consumption	[ kW ]	13,94	16,72	16,14	19,53	22,10
Nominal Current	[ A ]	26,44	31,48	30,76	35,37	39,00
FLA (1 compressor)	[ A ]	20	29	29	32	32
LRA (1 compressor)	[ A ]	130	130	130	135	135
POE Oil charge	[ l ]	3,25	3,25	3,25	3,3	3,25
<b>Finned coil evaporator</b>						
Front Surface	[m <sup>2</sup> ]	1,5	1,5	1,9	1,9	1,9
Geometry		25 x 22	25 x 22	25 x 22	25 x 22	25 x 22
Rows	[ - ]	4	4	4	4	4
Type of fins	[ - ]	Hydrophilic	Hydrophilic	Hydrophilic	Hydrophilic	Hydrophilic
Fin pitch	[ mm ]	2,1	2,1	2,1	2,1	2,1
SHR	[ - ]	0,84	0,80	0,90	0,85	0,81
<b>Indoor fan</b>						
Type		EC Plug Fan	EC Plug Fan	EC Plug Fan	EC Plug Fan	EC Plug Fan
Power supply	[V-ph-Hz]	400/3/50	400/3/50	400/3/50	400/3/50	400/3/50
Number of fans		3	3	3	3	3
Fans absorbed current	[ A ]	4,36	4,36	4,93	4,93	4,93
Fans absorbed power	[W]	2718	2718	3074	3074	3074
AESP nominal fan speed	[ Pa ]	<b>30</b>	<b>30</b>	<b>30</b>	<b>30</b>	<b>30</b>
AESP (maximum speed)	[Pa]	274,2	274,2	363	363	363
<b>Air Filter</b>						
Filtration		<b>G4</b>	<b>G4</b>	<b>G4</b>	<b>G4</b>	<b>G4</b>
Overall surface	[m <sup>2</sup> ]	4.49	4.49	4.49	4.49	4.49
Fire resistance class		1	1	1	1	1
<b>Electrical heaters</b>						
Total Heating Capacity	[kW]	9,6	12,8	12,8	12,8	12,8
N° of heaters		6	8	8	8	8
Material	[ - ]	Alluminium	Alluminium	Alluminium	Alluminium	Alluminium
<b>Hot gas Reheating Coil</b>						
Heating capacity	[ kW ]	-	-	51,30	52,70	53,90
Front Surface	[m <sup>2</sup> ]	1,5	1,5	1,9	1,9	1,9
<b>Hot Water reheating coil</b>						
Heating capacity @ 45/40°	[ kW ]	-	-	44,30	46,00	47,60
Front Surface	[m <sup>2</sup> ]	1,5	1,5	1,9	1,9	1,9
Water flow	[l/h]	-	-	7620	7912	8187
Water side pressure drop	[ kPa ]	-	-	34,00	35,00	39,00
Water valve pressure drop	[ kPa ]	-	-	22,68	24,45	26,18
Internal volume	[ dm <sup>3</sup> ]	-	-	5,0	5,0	5,0
<b>Humidifier</b>						
Max theoretical capacity	[ kg/h ]	8	8	8	8	8
Effective capacity	[ kg/h ]	10,29	10,02	10,73	10,48	10,14
Absorbed power	[ kW ]	6	6	6	6	6
<b>Frame</b>						
H	[mm]	1998	1998	1998	1998	1998
L	[mm]	2020	2020	2510	2510	2510
D	[mm]	795	795	795	795	795
Weight	[ kg ]	730	745	940	958	979

## b. DX UNITS (1 COMPRESSOR) – WATER COOLED

INNOV@	DHWDR/DHWUR	0060	0080	0100	0110
Air Flow	[ m3/h ]	1.785	2.150	3.530	3.530
<b>T water in/out 15/30 °C</b>					
Cooling Capacity @ 24°C, 50%	[ kW ]	6,2	8,3	10,3	11,5
Power consumption	[ kW ]	1,2	1,5	1,7	2,1
<b>T water in/out 40/45 °C (**)</b>					
Cooling Capacity @ 24°C, 50%	[ kW ]	5,3	7	8,9	10
Power consumption	[ kW ]	1,7	2,2	2,6	3,1
<b>Compressor</b>					
Type		Scroll	Scroll	Scroll	Scroll
Power supply	[ V/Ph/Hz ]	400/ 3+N /50	400/ 3+N /50	400/ 3+N /50	400/ 3+N /50
Nominal Current (**)	[ A ]	3,1	4	4,8	5,5
FLA	[ A ]	5	6	6	7
LRA	[ A ]	24	32	40	46
Oil charge	[ l ]	1	1	1,1	1,1
<b>Finned Coil Evaporator</b>					
Front surface	[ m2 ]	0,27	0,27	0,45	0,45
Geometry		25 x 21,65	25 x 21,65	25 x 21,65	25 x 21,65
Rows	[ - ]	3	4	3	3
Type of fins	[ - ]	Hydrophilic	Hydrophilic	Hydrophilic	Hydrophilic
Fin pitch	[ mm ]	1,8	1,8	1,8	1,8
SHR	[ - ]	0,98	0,95	1	1
<b>Indoor Fan</b>					
Type		EC Plug Fan	EC Plug Fan	EC Plug Fan	EC Plug Fan
Number of fans		1	1	1	1
Fans absorbed current	[ A ]	0,26	0,35	0,54	0,54
Fans absorbed power	[ W ]	163	215	337	337
AESP	[ Pa ]	30	30	30	30
AESP (maximum fanspeed)	[ Pa ]	550	531	473	473
<b>Air Filter</b>					
Filtration		G3	G3	G3	G3
Overall surface	[ m2 ]	2,2	2,2	3,6	3,6
Fire resistance class		1	1	1	1
<b>Electrical heaters</b>					
Total heating capacity	[ kW ]	1,6	1,6	3,2	3,2
N° of heaters		1	1	2	2
Material	[ - ]	Aluminium	Aluminium	Aluminium	Aluminium
<b>Hot Gas Reheating Coil</b>					
Heating capacity	[ kW ]	5,1	5,5	9	9
Front surface	[ m2 ]	0,22	0,22	0,37	0,37
<b>Hot Water Reheating Coil</b>					
Heating capacity @ water 45/40° C	[ kW ]	4,2	4,6	7,8	7,8
Front surface	[ m2 ]	0,22	0,22	0,37	0,37
Water Flow	[ m3/h ]	0,73	0,792	1,365	1,365
Water side pressure drop	[ kPa ]	8,2	9,4	15,5	15,5
Water valve pressure drop	[ kPa ]	3,3	3,9	4,4	4,4
Internal volume	[ dm3 ]	0,9	0,9	1,3	1,3
<b>Humidifier</b>					
Max theoretical capacity	[ kg/h ]	2,8	3,17	4,45	5,22
Effective capacity	[ kg/h ]	3	3	3	3
Absorbed power	[ kW ]	2,25	2,25	2,25	2,25
<b>Frame</b>					
H	[ mm ]	1.875	1.875	1.875	1.875
L	[ mm ]	600	600	900	900
D	[ mm ]	600	600	600	600
Weight	[ kg ]	162	169	207	232



**DX UNITS (1 COMPRESSOR) – WATER COOLED**

INNOV@	DHWDR/DHWUR	0130	0160	0190	0205
Air Flow	[ m <sup>3</sup> /h ]	3.700	5.100	5.100	5.100
<b>T water in/out 15/30 °C</b>					
Cooling Capacity @ 24°C, 50%	[ kW ]	13,6	18	21	23,1
Power consumption	[ kW ]	2,5	3,2	3,7	4,2
<b>T water in/out 40/45 °C (**)</b>					
Cooling Capacity @ 24°C, 50%	[ kW ]	11,7	15,5	17,8	19,7
Power consumption	[ kW ]	3,7	4,6	5,3	6,1
<b>Compressor</b>					
Type		Scroll	Scroll	Scroll	Scroll
Power supply	[ V/Ph/Hz ]	400/ 3+N/50	400/ 3+N/50	400/ 3+N/50	400/ 3+N/50
Nominal Current (**)	[ A ]	6,8	8,5	9,4	11,3
FLA	[ A ]	10	13	13	15
LRA	[ A ]	50	66	74	101
Oil charge	[ l ]	1,36	1,95	1,65	1,65
<b>Finned Coil Evaporator</b>					
Front surface	[ m <sup>2</sup> ]	0,45	0,53	0,53	0,53
Geometry		25 x 21,65	25 x 21,65	25 x 21,65	25 x 21,65
Rows	[ - ]	3	4	5	5
Type of fins	[ - ]	Hydrophilic	Hydrophilic	Hydrophilic	Hydrophilic
Fin pitch	[ mm ]	1,8	1,8	1,8	1,8
SHR	[ - ]	0,92	1	0,93	0,89
<b>Indoor Fan</b>					
Type		EC Plug Fan	EC Plug Fan	EC Plug Fan	EC Plug Fan
Number of fans		1	1	1	1
Fans absorbed current	[ A ]	0,5	1,05	1,19	1,19
Fans absorbed power	[ W ]	310	652	743	743
AESP	[ Pa ]	30	30	30	30
AESP (maximum fanspeed)	[ Pa ]	453	174	144	144
<b>Air Filter</b>					
Filtration		G3	G3	G3	G3
Overall surface	[ m <sup>2</sup> ]	3,6	5	5	5
Fire resistance class		1	1	1	1
<b>Electrical heaters</b>					
Total heating capacity	[ kW ]	3,2	3,2	3,2	3,2
N° of heaters		2	2	2	2
Material	[ - ]	Aluminium	Aluminium	Aluminium	Aluminium
<b>Hot Gas Reheating Coil</b>					
Heating capacity	[ kW ]	9,1	10,3	10,3	10,3
Front surface	[ m <sup>2</sup> ]	0,37	0,37	0,37	0,37
<b>Hot Water Reheating Coil</b>					
Heating capacity @ water 45/40° C	[ kW ]	8	9,2	9,2	9,2
Front surface	[ m <sup>2</sup> ]	0,37	0,37	0,37	0,37
Water Flow	[ m <sup>3</sup> /h ]	1,393	1,595	1,595	1,595
Water side pressure drop	[ kPa ]	16,1	20,3	20,3	20,3
Water valve pressure drop	[ kPa ]	4,6	6	6	6
Internal volume	[ dm <sup>3</sup> ]	1,3	1,3	1,3	1,3
<b>Humidifier</b>					
Max theoretical capacity	[ kg/h ]	5,01	10,09	6,9	6,5
Effective capacity	[ kg/h ]	3	3	3	3
Absorbed power	[ kW ]	2,25	2,25	2,25	2,25
<b>Frame</b>					
H	[ mm ]	1.875	1.875	1.875	1.875
L	[ mm ]	900	900	900	900
D	[ mm ]	600	600	600	600
Weight	[ kg ]	265	273	285	287

## DX UNITS (1 COMPRESSOR) – WATER COOLED

INNOV@	DHWDR/DHWUR	0201	0251	0281	0311	0401
Air Flow	[ m <sup>3</sup> /h ]	6800	6800	7280	7280	12950
<b>T water 15°C / 30°C</b>						
Cooling Capacity	[ kW ]	25,26	26,26	31,10	34,37	47,03
Power consumption	[ kW ]	4,26	4,49	5,47	6,41	8,51
<b>T water 40°C / 45°C (30% e.g.)</b>						
Cooling Capacity	[ kW ]	21,71	22,74	27,13	30,17	40,95
Power consumption	[ kW ]	5,84	6,16	7,40	8,66	11,55
<b>Compressor</b>						
Type		Scroll	Scroll	Scroll	Scroll	Scroll
Power supply	[V-ph-Hz]	400/3/50	400/3/50	400/3/50	400/3/50	400/3/50
Nominal Current	[ A ]	8,91	9,41	11,48	13,46	16,42
FLA	[ A ]	17	17	20	29	29
LRA	[ A ]	86	98	130	130	135
POE Oil charge	[l]	3,25	3,25	3,25	4,25	3,3
<b>Finned coil evaporator</b>						
Front Surface	[m <sup>2</sup> ]	0,7	0,7	0,9	0,9	1,3
Geometry		25 x 22	25 x 22	25 x 22	25 x 22	25 x 22
Rows	[ - ]	5	5	5	5	4
Type of fins	[ - ]	Hydrophilic	Hydrophilic	Hydrophilic	Hydrophilic	Hydrophilic
Fin pitch	[ mm ]	2,1	2,1	2,1	2,1	2,1
SHR	[ - ]	0,88	0,87	0,84	0,79	0,86
<b>Indoor fan</b>						
Type		EC Plug Fan	EC Plug Fan	EC Plug Fan	EC Plug Fan	EC Plug Fan
Number of fans		1	1	1	1	2
Fans absorbed current	[ A ]	1,61	1,61	2,01	2,01	3,07
Fans absorbed power	[W]	1007	1007	1252	1252	1912
AESP	[Pa]	30	30	30	30	30
AESP (maximum speed)	[Pa]	367,5	367,5	298,4	298,4	382,2
<b>Air Filter</b>						
Filtration		G4	G4	G4	G4	G4
Overall surface	[m <sup>2</sup> ]	1.44	1.44	1.44	2.92	2.92
Fire resistance class		1	1	1	1	1
<b>Electrical heaters</b>						
Total Heating Capacity	[kW]	6,4	6,4	6,4	6,4	9,6
N° of heaters		4	4	4	4	6
Material	[ - ]	Alluminium	Alluminium	Alluminium	Alluminium	Alluminium
<b>Hot gas Reheating Coil</b>						
Heating capacity	[ kW]	16,50	16,70	17,30	-	37,20
Front Surface	[m <sup>2</sup> ]	0,7	0,7	0,9	0,9	1,3
<b>Hot Water reheating coil</b>						
Heating capacity @ 45/40° water T	[ kW]	14,50	14,70	14,90	-	29,60
Front Surface	[m <sup>2</sup> ]	0,7	0,7	0,9	0,9	1,3
Water flow	[l/h]	2494	2528	2563	-	5091
Water side pressure drop	[ kPa ]	13,00	13,00	13,00	-	42,00
Water valve pressure drop	[ kPa ]	14,72	15,13	15,55	-	10,13
Internal volume	[ dm <sup>3</sup> ]	1,6	1,6	1,6	-	3,2
<b>Humidifier</b>						
Max theoretical capacity	[ kg/h ]	10,16	9,98	9,54	9,28	10,45
Effective capacity	[ kg/h ]	9,00	8,83	8,64	8,39	8,78
Absorbed power	[ kW ]	2,25	2,25	2,25	2,25	6
<b>Frame</b>						
H	[mm]	1998	1998	1998	1998	1998
L	[mm]	1010	1010	1270	1270	1760
D	[mm]	795	795	795	795	795
Weight	[ kg ]	375	385	490	505	595

### c. DX UNITS (2 COMPRESSORS) – WATER COOLED

INNOV@	DHWDR/DHWUR	0272	0302	0362	0422	0452
Air Flow	[ m <sup>3</sup> /h ]	12950	12950	12950	12950	12950
<b>T water 15°C</b>						
Cooling Capacity	[ kW ]	27.90	34.60	40.60	48.00	50.60
Power consumption	[ kW ]	5.42	6.96	7.94	9.52	9.98
<b>T water 40°C (30% e.g.)</b>						
Cooling Capacity	[ kW ]	23.50	28.90	34.00	39.94	42.12
Power consumption	[ kW ]	7.42	9.26	10.70	12.72	13.34
<b>Compressor</b>						
Type		Scroll	Scroll	Scroll	Scroll	Scroll
Power supply	[V-ph-Hz]	400/3/50	400/3/50	400/3/50	400/3/50	400/3/50
Nominal Current	[ A ]	12.2	16.2	17.4	21.4	22.6
FLA (1 compressor)	[ A ]	10	13	14	17	17
LRA (1 compressor)	[ A ]	50	66	74	86	98
POE Oil charge	[l]	1.36	1.36	1.65	3.25	3.25
<b>Finned coil evaporator</b>						
Front Surface	[m <sup>2</sup> ]	1.3	1.3	1.3	1.3	1.3
Geometry		25 x 21,65	25 x 21,65	25 x 21,65	25 x 21,65	25 x 21,65
Rows	[ - ]	3	3	3	4	4
Type of fins	[ - ]	Hydrophilic	Hydrophilic	Hydrophilic	Hydrophilic	Hydrophilic
Fin pitch	[ mm ]	1.8	1.8	1.8	1.8	1.8
SHR	[ - ]	1.00	0.99	0.98	0.97	0.98
<b>Indoor fan</b>						
Type		EC Plug Fan	EC Plug Fan	EC Plug Fan	EC Plug Fan	EC Plug Fan
Number of fans		2	2	2	2	2
Fans absorbed current	[ A ]	4.3	4.3	4.3	4.4	4.4
Fans absorbed power	[W]	2500	2500	2500	2595	2600
AESP with std fan	[Pa]	30	30	30	30	30
AESP (maximum speed)	[Pa]	425	425	425	355	355
<b>Air Filter</b>						
Filtration		G4	G4	G4	G4	G4
Overall surface	[m <sup>2</sup> ]	2.92	2.92	2.92	2.92	2.92
Fire resistance class		1	1	1	1	1
<b>Electrical heaters</b>						
Total Heating Capacity	[kW]	9.6	9.6	9.6	9.6	9.6
N° of heaters		3	3	3	3	3
Material	[ - ]	Aluminium	Aluminium	Aluminium	Aluminium	Aluminium
<b>Hot gas Reheating Coil</b>						
Heating capacity	[ kW]	34.1	33.7	33.7	41.6	42.3
Front Surface	[m <sup>2</sup> ]	1.05	1.05	1.05	1.05	1.05
<b>Hot Water reheating coil</b>						
Heating capacity @ 45/40° water T	[ kW]	39.6	41	42	42	42
Front Surface	[m <sup>2</sup> ]	1.05	1.05	1.05	1.05	1.05
Water flow	[m <sup>3</sup> /h]	4.936	5.021	5.159	5.159	5.159
Water side pressure drop	[ kPa ]	39.6	41.0	42.0	42.0	42.0
Water valve pressure drop	[ kPa ]	7.69	8.42	9.19	10.13	10.61
Internal volume	[ dm <sup>3</sup> ]	2.786	2.786	2.786	2.786	2.786
<b>Humidifier</b>						
Max theoretical capacity	[ kg/h ]	26.00	21.66	22.41	21.09	23.20
Effective capacity	[ kg/h ]	8	8	8	8	8
Absorbed power	[ kW]	6	6	6	6	6
<b>Frame</b>						
H	[mm]	1998	1998	1998	1998	1998
L	[mm]	1750	1750	1750	1750	1750
D	[mm]	795	795	795	795	795
Weight	[ kg ]	565	580	590	605	615

## DX UNITS (2 COMPRESSORS) – WATER COOLED

INNOV@	DHWDR/DHWUR	0532	0592	0602	0692	0762
<b>Air Flow</b>	[ m3/h ]	14150	14150	19415	19415	19415
<b>T water 15°C</b>						
<b>Cooling Capacity</b>	[ kW ]	59,84	66,19	71,23	79,82	87,59
<b>Power consumption</b>	[ kW ]	10,92	12,76	12,82	14,86	16,88
<b>T water 40°C (30% e.g.)</b>						
<b>Cooling Capacity</b>	[ kW ]	52,32	58,06	62,10	69,85	77,02
<b>Power consumption</b>	[ kW ]	14,78	17,28	17,34	20,18	22,98
<b>Compressor</b>						
<b>Type</b>		<b>Scroll</b>	<b>Scroll</b>	<b>Scroll</b>	<b>Scroll</b>	<b>Scroll</b>
<b>Power supply</b>	[V-ph-Hz]	400/3/50	400/3/50	400/3/50	400/3/50	400/3/50
<b>Nominal Current</b>	[ A ]	12,2	16,2	17,4	21,4	22,6
<b>FLA (1 compressor)</b>	[ A ]	20	29	29	32	32
<b>LRA (1 compressor)</b>	[ A ]	130	130	130	135	135
<b>POE Oil charge</b>	[l]	3,25	3,25	3,25	3,3	3,25
<b>Finned coil evaporator</b>						
<b>Front Surface</b>	[m2]	1,5	1,5	1,9	1,9	1,9
<b>Geometry</b>		25 x 22	25 x 22	25 x 22	25 x 22	25 x 22
<b>Rows</b>	[ - ]	4	4	4	4	4
<b>Type of fins</b>	[ - ]	Hydrophilic	Hydrophilic	Hydrophilic	Hydrophilic	Hydrophilic
<b>Fin pitch</b>	[ mm ]	2,1	2,1	2,1	2,1	2,1
<b>SHR</b>	[ - ]	0,79	0,76	0,85	0,80	0,76
<b>Indoor fan</b>						
<b>Type</b>		EC Plug Fan	EC Plug Fan	EC Plug Fan	EC Plug Fan	EC Plug Fan
<b>Number of fans</b>		2	2	2	2	2
<b>Fans absorbed current</b>	[ A ]	3,98	3,98	4,41	4,41	4,41
<b>Fans absorbed power</b>	[W]	2500	2500	2500	2595	2600
<b>AESP with std fan</b>	[Pa]	<b>30</b>	<b>30</b>	<b>30</b>	<b>30</b>	<b>30</b>
<b>AESP (maximum speed)</b>	[Pa]	274,2	274,2	363	363	363
<b>Air Filter</b>						
<b>Filtration</b>		<b>G4</b>	<b>G4</b>	<b>G4</b>	<b>G4</b>	<b>G4</b>
<b>Overall surface</b>	[m2]	4,49	4,49	4,49	4,49	4,49
<b>Fire resistance class</b>		1	1	1	1	1
<b>Electrical heaters</b>						
<b>Total Heating Capacity</b>	[kW]	9,6	9,6	12,8	12,8	12,8
<b>N° of heaters</b>		6	6	8	8	8
<b>Material</b>	[ - ]	Alluminium	Alluminium	Alluminium	Alluminium	Alluminium
<b>Hot gas Reheating Coil</b>						
<b>Heating capacity</b>	[ kW ]	38,60	-	51,30	52,70	53,90
<b>Front Surface</b>	[m2]	1,5	1,5	1,9	1,9	1,9
<b>Hot Water reheating coil</b>						
<b>Heating capacity @ 45/40° water T</b>	[ kW ]	31,30	-	44,30	46,00	47,60
<b>Front Surface</b>	[m2]	1,5	1,5	1,9	1,9	1,9
<b>Water flow</b>	[m3/h]	5,384	-	7,620	7,912	8,187
<b>Water side pressure drop</b>	[ kPa ]	45,00	-	34,00	35,00	39,00
<b>Water valve pressure drop</b>	[ kPa ]	29,00	-	27,00	27,00	27,00
<b>Internal volume</b>	[ dm3 ]	3,2	-	5,0	5,0	5,0
<b>Humidifier</b>						
<b>Max theoretical capacity</b>	[ kg/h ]	8	8	8	8	8
<b>Effective capacity</b>	[ kg/h ]	10,02	9,61	10,46	10,12	9,85
<b>Absorbed power</b>	[ kW ]	6	6	6	6	6
<b>Frame</b>						
<b>H</b>	[mm]	1998	1998	1998	1998	1998
<b>L</b>	[mm]	2020	2020	2510	2510	2510
<b>D</b>	[mm]	795	795	795	795	795
<b>Weight</b>	[ kg ]	730	745	940	958	979

**DX UNITS (2 COMPRESSORS) – WATER COOLED**

INNOV@	DHWDR/DHWUR	0080	0110	0140	0160	0200	0230
<b>Total cooling capacity @ 7/12 ° Water T.-external air T.24° 50% R.H.</b>	[kW]	7,7	10,6	14,2	15,8	21,2	23,4
<b>Air Flow</b>	[ m3/h ]	2.300	2.400	3.800	3.800	5.100	5.100
<b>Water flow</b>	[l/s]	0,36	0,5	0,67	0,75	1	1,06
<b>Water pressure drop</b>	[kPa]	24,59	52,46	23,26	32,18	41,45	49,25
<b>Finned coil evaporator</b>							
<b>Frontal surface</b>	[m2]	0,26	0,26	0,44	0,44	0,51	0,51
<b>Geometry</b>		25 x 21,65	25 x 21,65	25 x 21,65	25 x 21,65	25 x 21,65	25 x 21,65
<b>Rows</b>	[ - ]	3	4	3	4	4	5
<b>Type of fins</b>	[ - ]	Hydrophilic	Hydrophilic	Hydrophilic	Hydrophilic	Hydrophilic	Hydrophilic
<b>Fin pitch</b>	[ mm ]	1,8	1,8	1,8	1,8	1,8	1,8
<b>SHR</b>	[ - ]	0,88	0,84	0,84	0,83	0,84	0,83
<b>Indoor Fan</b>							
<b>Type</b>		Radial -EC	Radial -EC	Radial -EC	Radial -EC	Radial -EC	Radial -EC
<b>Power supply</b>	[ V/Ph/Hz ]	400/3/50	400/3/50	400/3/50	400/3/50	400/3/50	400/3/50
<b>Number of fans</b>		1	1	1	1	1	1
<b>Fans Absorbed current</b>	[ A ]	0,34	0,39	0,63	0,64	0,91	1,03
<b>Fans absorbed power</b>	[W]	211	245	395	397	564	643
<b>AESP</b>	[Pa]	30	30	30	30	30	30
<b>AESP @ max fan speed</b>	[Pa]	506	473	432	401	174	144
<b>Air Filter</b>							
<b>Filtration</b>		G3	G3	G3	G3	G3	G3
<b>Overall surface</b>	[m2]	2,2	2,2	3,6	3,6	5	5
<b>Fire resistance class</b>		1	1	1	1	1	1
<b>Electrical heaters</b>							
<b>Total heating capacity</b>	[kW]	1,6	1,6	3,2	3,2	3,2	3,2
<b>N° of heaters</b>		1	1	2	2	3	3
<b>Material</b>	[ - ]	Aluminium	Aluminium	Aluminium	Aluminium	Aluminium	Aluminium
<b>Hot Water Reheating Coil</b>							
<b>Heating capacity @ 45/40° C water T.</b>	[ kW ]	4,7	4,8	8,1	8,1	9,2	9,2
<b>Front surface</b>	[m2]	0,22	0,22	0,37	0,37	0,37	0,37
<b>Water Flow</b>	[m3/h]	0,815	0,83	1,409	1,409	1,595	1,595
<b>Water side pressure drop</b>	[ kPa ]	9,9	10,3	16,4	16,4	20,3	20,3
<b>Water valve pressure drop</b>	[ kPa ]	4,15	4,31	4,7	4,7	6,2	6,2
<b>Internal volume</b>	[ dm3 ]	0,9	0,9	1,3	1,3	1,3	1,3
<b>Humidifier</b>							
<b>Max theoretical capacity</b>	[ kg/h ]	2,92	3,55	6,44	5,83	9,87	8,66
<b>Effective capacity</b>	[ kg/h ]	3	3	3	3	3	3
<b>Absorbed power</b>	[ kW ]	2,25	2,25	2,25	2,25	2,25	2,25
<b>Sound pressure level (*)</b>	[dB(A)]	48	50	51	51	52	52
<b>Frame</b>							
<b>H</b>	[mm]	1.875	1.875	1.875	1.875	1.875	1.875
<b>L</b>	[mm]	600	600	900	900	900	900
<b>D</b>	[mm]	600	600	600	600	600	600
<b>Weight</b>	[kg]	125	135	150	160	170	175

(\*) obtained at: height 1,5 m., unit frontal side 2 m. in free field, AESP 20PA - unit with downflow execution

#### d. CWC UNITS (NOMINAL AIR FLOW)

INNOV@	DHCDR/DHCUR	0080	0110	0140	0160	0200	0230
Total cooling capacity @ 7/12 ° Water T.-external air T.24° 50% R.H.	[kW]	7,7	10,6	14,2	15,8	21,2	23,4
Air Flow	[ m3/h ]	2.300	2.400	3.800	3.800	5.100	5.100
Water flow	[l/s]	0,36	0,5	0,67	0,75	1	1,06
Water pressure drop Finned coil evaporator	[kPa]	24,59	52,46	23,26	32,18	41,45	49,25
Frontal surface	[m2]	0,26	0,26	0,44	0,44	0,51	0,51
Geometry		25 x 21,65	25 x 21,65	25 x 21,65	25 x 21,65	25 x 21,65	25 x 21,65
Rows	[ - ]	3	4	3	4	4	5
Type of fins	[ - ]	Hydrophilic	Hydrophilic	Hydrophilic	Hydrophilic	Hydrophilic	Hydrophilic
Fin pitch	[ mm ]	1,8	1,8	1,8	1,8	1,8	1,8
SHR	[ - ]	0,88	0,84	0,84	0,83	0,84	0,83
Indoor Fan Type		Radial -EC	Radial -EC	Radial -EC	Radial -EC	Radial -EC	Radial -EC
Power supply	[ V/Ph/Hz ]	400/3/50	400/3/50	400/3/50	400/3/50	400/3/50	400/3/50
Number of fans		1	1	1	1	1	1
Fans Absorbed current	[ A ]	0,34	0,39	0,63	0,64	0,91	1,03
Fans absorbed power	[W]	211	245	395	397	564	643
AESP	[Pa]	30	30	30	30	30	30
AESP @ max fan speed	[Pa]	506	473	432	401	174	144
Air Filter Filtration		G3	G3	G3	G3	G3	G3
Overall surface	[m2]	2,2	2,2	3,6	3,6	5	5
Fire resistance class		1	1	1	1	1	1
Electrical heaters Total heating capacity	[kW]	1,6	1,6	3,2	3,2	3,2	3,2
N° of heaters		1	1	2	2	3	3
Material	[ - ]	Aluminium	Aluminium	Aluminium	Aluminium	Aluminium	Aluminium
Hot Water Reheating Coil Heating capacity @ 45/40° C water T.	[ kW ]	4,7	4,8	8,1	8,1	9,2	9,2
Front surface	[m2]	0,22	0,22	0,37	0,37	0,37	0,37
Water Flow	[m3/h]	0,815	0,83	1,409	1,409	1,595	1,595
Water side pressure drop	[ kPa ]	9,9	10,3	16,4	16,4	20,3	20,3
Water valve pressure drop	[ kPa ]	4,15	4,31	4,7	4,7	6,2	6,2
Internal volume	[ dm3 ]	0,9	0,9	1,3	1,3	1,3	1,3
Humidifier Max theoretical capacity	[ kg/h ]	2,92	3,55	6,44	5,83	9,87	8,66
Effective capacity	[ kg/h ]	3	3	3	3	3	3
Absorbed power	[ kW ]	2,25	2,25	2,25	2,25	2,25	2,25
Sound pressure level (*)	[dB(A)]	48	50	51	51	52	52
Frame H	[mm]	1.875	1.875	1.875	1.875	1.875	1.875
L	[mm]	600	600	900	900	900	900
D	[mm]	600	600	600	600	600	600
Weight	[kg]	125	135	150	160	170	175
(*) obtained at: height 1,5 m.,unit frontal side 2 m. in free field, AESP 20PA - unit with downflow execution							

## CWC UNITS (NOMINAL AIR FLOW)

INNOV@	DHCDR/DHCUR	0300	0380	0400	0500	0650	0750
<b>Total cooling capacity @ 7/12° Water T. – external air T. 24° 50% R.H.</b>	[kW]	32.4	47.6	37.5	51.8	63.8	83.1
<b>Air Flow</b>	[ m3/h ]	8120	8120	14500	14500	14500	14500
<b>Water flow</b>	[l/s]	1.55	2.27	1.80	2.47	3.05	3.97
<b>Total water pressure drop</b>	[ kPa ]	46	55.8	37	39	71	73.3
<b>Finned coil evaporator</b>							
<b>Front Surface</b>	[m2]	1.10	1.05	1.90	1.90	1.90	1.85
<b>Geometry</b>		25 x 21,65	25 x 21,65	25 x 21,65	25 x 21,65	25 x 21,65	25 x 21,65
<b>Rows</b>	[ - ]	3	6	2	3	4	6
<b>Type of fins</b>	[ - ]	Hydrofilic	Hydrofilic	Hydrofilic	Hydrofilic	Hydrofilic	Hydrofilic
<b>Fin pitch</b>	[ mm ]	1.8	1.8	1.8	1.8	1.8	1.8
<b>SHR</b>	[ - ]	0.83	0.77	0.84	0.83	0.82	0.8
<b>Indoor fan</b>							
<b>Type</b>		EC Plug Fan	EC Plug Fan	EC Plug Fan	EC Plug Fan	EC Plug Fan	EC Plug Fan
<b>Power supply</b>	[V-ph-Hz]	400/3/50	400/3/50	400/3/50	400/3/50	400/3/50	400/3/50
<b>Number of fans</b>		1	1	1	2	2	2
<b>Fans absorbed current</b>	[ A ]	2.5	1.74	4.6	4.8	5.0	3.29
<b>Fans absorbed power</b>	[W]	1482	1000	2756	2816	2942	1800
<b>AESP with std fan</b>	[Pa]	30	30	30	30	30	30
<b>ESP (maximum speed)</b>	[Pa]	380	330	430	405	385	350
<b>Air Filter</b>							
<b>Filtration</b>		G4	G4	G4	G4	G4	G4
<b>Overall surface</b>	[m2]	1.44	1.44	2.92	2.92	2.92	2.92
<b>Fire resistance class</b>		1	1	1	1	1	1
<b>Electrical heaters</b>							
<b>Total Heating Capacity</b>	[kW]	3.2	6.4	6.4	6.4	6.4	9.6
<b>N° of heaters</b>		2	2	3	3	3	3
<b>Material</b>	[ - ]	Aluminium	Aluminium	Aluminium	Aluminium	Aluminium	Aluminium
<b>Hot Water reheating coil</b>							
<b>Heating capacity @ 45/40° water T</b>	[ kW]	14.5	14.7	14.9	25.8	27	29.6
<b>Front Surface</b>	[m2]	0.65	0.65	1.05	1.05	1.05	1.05
<b>Water flow</b>	[m3/h]	2.494	2.528	2.563	4.438	4.644	5.091
<b>Water side pressure drop</b>	[ kPa ]	13	13	13	33	35	42
<b>Water valve pressure drop</b>	[ kPa ]	14.72	15.13	15.55	7.69	8.42	10.13
<b>Internal volume</b>	[ dm3]	1.44	1.44	2.78	2.78	2.78	2.78
<b>Humidifier</b>							
<b>Max theoretical capacity</b>	[ kg/h ]	19.6	19.6	41.1	35.4	23.6	23.6
<b>Effective capacity</b>	[ kg/h ]	8	8	8	8	8	8
<b>Absorbed power</b>	[ kW]	6	6	6	6	6	6
<b>Sound pressure level</b>	[dB(A)]	58	60	60	61	61.5	62
<b>Power Supply</b>	V/Ph/H	230/1/50	230/1/50	230/1/50	230/1/50	230/1/50	230/1/50
<b>Frame</b>							
<b>H</b>	[mm]	1998	1998	1998	1998	1998	1998
<b>L</b>	[mm]	1000	1010	1750	1750	1750	1760
<b>D</b>	[mm]	795	795	795	795	795	795
<b>Weight</b>	[kg]	310	350	370	410	430	475

(\* ) Obtained at: height 1,5 m., unit frontal side 2 m. in free field, AESP 20 Pa – unit with down flow execution

## CWC UNITS (NOMINAL AIR FLOW)

INNOV@		DHCDR0900	DHCDR1000	DHCDR1200	DHCDR1500	DHCDR1800	DHCDR2100
		DHCUR0900	DHCUR1000	DHCUR1200			
Total cooling capacity @ 7/12° Water T. – external air T. 24° 50% R.H.	[kW]	87.4	101.4	137.9	144,18	177,7	248,48
Air Flow	[l/h]	14376	18352	22974	24799	30564	42739
Water flow	[ m3/h ]	21400	21400	21400	26200	26200	36120
Total water pressure drop	[ kPa ]	33,8	62,6	124,0	59,5	103,0	214,3
<b>Finned coil evaporator</b>							
Front Surface	[m2]	2,7	2,7	2,7	5,4	5,4	7,0
Geometry		25 x 22	25 x 22	25 x 22	25 x 22	25 x 22	25 x 22
Rows	[ - ]	3	4	6	4	6	6
Type of fins	[ - ]	Hydrophilic	Hydrophilic	Hydrophilic	Hydrophilic	Hydrophilic	Hydrophilic
Fin pitch	[ mm ]	1,8	1,8	1,8	1,8	1,8	1,8
SHR	[ - ]	0,82	0,77	0,73	0,76	0,72	0,71
<b>Indoor fan</b>							
Type		EC Plug Fan	EC Plug Fan	EC Plug Fan	EC Plug Fan	EC Plug Fan	EC Plug Fan
Power supply	[V-ph-Hz]	400/3/50	400/3/50	400/3/50	400/3/50	400/3/50	400/3/50
Number of fans		2	2	3		2	
Fans absorbed current	[ A ]	5,25	5,70	6,11	6,86	7,16	11,29
Fans absorbed power	[kW]	3,276	3,556	3,808	4,279	4,465	7,038
AESP with std fan	[Pa]	30	30	30	30	30	30
AESP (maximum speed)	[Pa]	335,9	311,9	283,9	68,6	54,6	112,2
<b>Air Filter</b>							
Filtration		G4	G4	G4	G4	G4	G4
Overall surface	[m2]	4.49	4.49	4.49		5.75	
Fire resistance class		1	1	1	1	1	1
<b>Electrical heaters</b>							
Total Heating Capacity	[kW]	9,6	9,6	9,6	-	-	-
N° of heaters		4	4	4	-	-	-
Material	[ - ]	Alluminium	Alluminium	Alluminium	Alluminium	Alluminium	Alluminium
<b>Hot Water reheating coil</b>							
Heating capacity @ 45/40° water T	[ kW]	50,20	53,82	53,82	-	-	-
Front Surface	[m2]	2,7	2,7	2,7	5,4	5,4	7,0
Water flow	[l/h]	8634	9257	9257	-	-	-
Water side pressure drop	[ kPa ]	42,59	48,13	48,13	-	-	-
Water valve pressure drop	[ kPa ]	11,93	13,71	13,71	-	-	-
Internal volume	[ dm3]	4,9	4,9	4,9	-	-	-
<b>Humidifier</b>							
Max theoretical capacity	[ kg/h ]	54.7	36.4	36.4	-	-	-
Effective capacity	[ kg/h ]	8	8	8	-	-	-
Absorbed power	[ kW]	6	6	6	-	-	-
Sound pressure level	[dB(A)]	63	63.5	65	-	-	-
Power Supply	V/Ph/H	230/1/50	230/1/50	230/1/50	-	-	-
<b>Frame</b>							
H	[mm]	1998	1998	1998	1998	1998	1998
L	[mm]	2510	2510	2510	2510	2510	3160
D	[mm]	795	795	795	950	950	950
Weight	[kg]	490	510	530	720	753	785

(\*) Obtained at: height 1,5 m., unit frontal side 2 m. in free field, AESP 20 Pa – unit with down flow execution



## 9. REMOTE CONDENSER TECHNICAL DATA COLLECTION

### a. Remote Condenser – Standard Execution - SHVN

SHVN		SVHN 7/7	SVHN 13/9	SVHN 13/9	SVHN 13/9	SVHN 20/4	SVHN 20/4	SVHN 23/2	SVHN 38/1
<b>INNOV@ models</b>		<b>0060</b>	<b>0080</b>	<b>0100</b>	<b>0110</b>	<b>0130</b>	<b>0160</b>	<b>0190</b>	<b>0205</b>
Power supply	V/ph/Hz	230/1/50	230/1/50	230/1/50	230/1/50	230/1/50	230/1/50	230/1/50	230/1/50
Air Flow	m3/h	2.400	3.200	3.200	3.200	4.600	4.600	7.200	8.400
Absorbed power	W	180	270	270	270	360	360	540	720
Absorbed current	A	0,85	1,2	1,2	1,2	1,7	1,7	2,5	3,4
Fans	mm	1 x 350	2 x 330	2 x 330	2 x 330	2 x 350	2 x 350	3 x 350	4 x 350
Sound pressure level in f.f.	dB(A)	40	41	41	41	43	43	45	46
Dimensions	L mm	723	1.057	1.057	1.057	1.294	1.294	1.853	1.298
(vertical airflow)	P mm	600	500	500	500	600	600	600	1150
	H mm	763	600	600	600	763	763	763	763
Dimensions	L mm	723	1.057	1.057	1.057	1.294	1.294	1.853	1.298
(horizontal air flow)	P mm	363	305	305	305	363	363	363	363
	H mm	560	460	460	460	560	560	560	1130
Weight	kg	16	25	25	25	37	37	42	64

SHVN		38/1	38/1	38/1	46/5	61 V	38/1	46/5
<b>INNOV@ models</b>	Mod.	<b>0201</b>	<b>0251</b>	<b>0281</b>	<b>0311</b>	<b>0401</b>	<b>0272</b>	<b>0302</b>
Power supply	V/Ph/Hz	220/1/50	220/1/50	220/1/50	220/1/50	220/1/50	220/1/50	220/1/50
Air flow	m3/h	8400	8400	8400	14400	14900	8400	14400
Absorbed power	W	720	720	720	1080	1370	720	1080
Absorbed current	A	3.4	3.4	3.4	5.1	6.4	3.4	5.1
Fans	Nr.	4	4	4	6	2	4	6
	mm	350	350	350	350	500	350	350
Sound pressure level in f.f.	dB(A)	46	46	46	48	53	46	48
Dimensions	L mm	1298	1298	1298	1853	2393	1298	1853
[vertical air flow]	D mm	1150	1150	1150	1150	1110	1150	1150
	H mm	863	863	863	863	1270	863	863
Dimensions	L mm	1298	1298	1298	1853	2373	1298	1853
[horizontal air flow]	D mm	380	380	380	380	705	380	380
	H mm	1130	1130	1130	1130	1040	1130	1130
Weight	kg	64	64	64	81	177	64	81

SHVN		46/5	61 V	61 V	79 V	79 V	94 V	94 V	106 V
<b>INNOV@ models</b>	Mod.	<b>0362</b>	<b>0422</b>	<b>0452</b>	<b>0532</b>	<b>0592</b>	<b>0602</b>	<b>0692</b>	<b>0762</b>
Power supply	V/Ph/Hz	220/1/50	220/1/50	220/1/50	220/1/50	220/1/50	220/1/50	220/1/50	220/1/50
Air flow	m3/h	14400	14900	14900	23460	23460	22360	22360	31280
Absorbed power	W	1080	1370	1370	2050	2050	2050	2050	2740
Absorbed current	A	5.1	6.4	6.4	9.6	9.6	9.6	9.6	12.8
Fans	Nr.	6	2	2	3	3	3	3	4
	mm	350	500	500	500	500	500	500	500
Sound pressure level in f.f.	dB(A)	48	53	53	54	54	54	54	55
Dimensions	L mm	1853	2393	2393	3393	3393	3393	3393	4393
[vertical air flow]	D mm	1150	1110	1110	1110	1110	1110	1110	1110
	H mm	863	1270	1270	1270	1270	1270	1270	1270
Dimensions	L mm	1853	2373	2373	3373	3373	3373	3373	4373
[horizontal air flow]	D mm	380	705	705	705	705	705	705	705
	H mm	1130	1040	1040	1040	1040	1040	1040	1040
Weight	kg	81	177	177	214	214	239	239	239

- Connection between INNOV@ double circuit and 2 remote condensers single circuit.

### Basic Execution

Model		2 x SHVN 20/4	2 x SHVN 20/4	2 x SHVN 23/2	2 x SHVN 38/1	2 x SHVN 38/1	2 x SHVN 38/1	2 x SHVN 38/1	2 x SHVN 46/5	2 x SHVN 61 V	2 x SHVN 61 V
INNOV@	mod.	0272	0302	0362	0422	0452	0532	0592	0602	0692	0762
Nr. Of fans x Ø	mm	2 x 350	2 x 350	3 x 350	4 x 350	4 x 350	4 x 350	4 x 350	6 x 350	2 x 500	2 x 500
Air Flow	m <sup>3</sup> /h	4600	4600	7200	8400	8400	8400	8400	14400	14900	14900
Power supply	V/ph/Hz	220/1/50	220/1/50	220/1/50	220/1/50	220/1/50	220/1/50	220/1/50	220/1/50	220/1/50	220/1/50
Absorbed power	W	360	360	540	720	720	720	720	1080	1370	1370
Absorbed current	A	1,7	1,7	2,5	3,4	3,4	3,4	3,4	5,1	6,4	6,4
Sound pressure level in free field	dB(A)	43	43	45	46	46	46	46	48	53	53
Dimensions in case of vertical air flow	L mm	1298	1298	1853	1298	1298	1298	1298	1853	2393	2393
	D mm	600	600	600	1150	1150	1150	1150	1150	1110	1110
	H mm	763	763	763	863	863	863	863	863	1270	1270
Dimensions in case of horizontal air flow	L mm	1298	1298	1853	1298	1298	1298	1298	1853	2373	2373
	D mm	380	380	380	380	380	380	380	380	705	705
	H mm	570	570	570	1130	1130	1130	1130	1130	1040	1040
Weight	kg	37	37	42	64	64	64	64	81	177	177

### b. Remote Condenser – Low Noise Execution – SHVS

Model		SVHS 8/2	SVHS 18/0	SVHS 18/0	SVHS 18/0	SVHS 20/2	SVHS 20/2	SVHS 27/1	SVHS 36/0
<b>INNOV@ Models</b>		<b>60</b>	<b>80</b>	<b>100</b>	<b>110</b>	<b>130</b>	<b>160</b>	<b>190</b>	<b>205</b>
Power supply	V/ph/Hz	230/1/50	230/1/50	230/1/50	230/1/50	230/1/50	230/1/50	230/1/50	230/1/50
Air Flow	m3/h	2.200	4.500	4.500	4.500	3.900	3.900	5.200	9.000
Absorbed power	W	130	210	210	210	210	210	280	420
Absorbed current	A	0,6	1	1	1	1	1	1,3	2
Fans	mm	2 x 330	3 x 350	3 x 350	3 x 350	3 x 350	3 x 350	4 x 350	6 x 350
Sound pressure level in f.f.	dB(A)	32	35	35	35	35	35	36	38
Dimensions	L mm	1.057	1.853	1.853	1.853	1.853	1.853	1.298	1.853
(vertical airflow)	P mm	500	600	600	600	600	600	1150	1150
	H mm	600	763	763	763	763	763	863	863
Dimensions	L mm	1.057	1.853	1.853	1.853	1.853	1.853	1.298	1.853
(horizontal air flow)	P mm	305	305	305	305	305	305	363	363
	H mm	460	460	460	460	460	460	1130	1130
Weight	kg	21	42	42	42	48	48	64	72

SHVS		36/0	36/0	36/0	48/1	70 V	36/0	48/1
<b>INNOV@ models</b>	Mod.	<b>0201</b>	<b>0251</b>	<b>0281</b>	<b>0311</b>	<b>0401</b>	<b>0272</b>	<b>0302</b>
Power supply	V/Ph/Hz	220/1/50	220/1/50	220/1/50	220/1/50	220/1/50	220/1/50	220/1/50
Air flow	m3/h	9000	9000	9000	12000	18000	9000	12000
Absorbed power	W	420	420	420	560	1125	420	560
Absorbed current	A	2.0	2.0	2.0	2.6	5.1	2.0	2.6
Fans	Nr.	6	6	6	8	3	6	8
	mm	350	350	350	350	630	350	350
Sound pressure level in f.f.	dB(A)	38	38	38	39	42	38	39
Dimensions	L mm	1853	1853	1853	2410	3393	1853	2410
[vertical air flow]	D mm	1150	1150	1150	1150	1110	1150	1150
	H mm	863	863	863	863	1270	863	863
Dimensions	L mm	1853	1853	1853	2410	3373	1853	2410
[horizontal air flow]	D mm	380	380	380	380	705	380	380
	H mm	1130	1130	1130	1130	1040	1130	1130
Weight	kg	81	81	81	104	226	81	104

SHVS		48/1	70 V	70 V	87 V	87 V	97 V	97 V	111 V
<b>INNOV@ models</b>	Mod.	<b>0362</b>	<b>0422</b>	<b>0452</b>	<b>0532</b>	<b>0592</b>	<b>0602</b>	<b>0692</b>	<b>0762</b>
Power supply	V/Ph/Hz	220/1/50	220/1/50	220/1/50	220/1/50	220/1/50	220/1/50	220/1/50	220/1/50
Air flow	m3/h	12000	18000	18000	24000	24000	22400	22400	30000
Absorbed power	W	560	1125	1125	1500	1500	1500	1500	1875
Absorbed current	A	2.6	5.1	5.1	6.8	6.8	6.8	6.8	8.5
Fans	Nr.	8	3	3	4	4	4	4	5
	mm	350	630	630	630	630	630	630	630
Sound pressure level in f.f.	dB(A)	39	42	42	43	43	43	43	44
Dimensions	L mm	2410	3393	3393	4393	4393	4393	4393	5393
[vertical air flow]	D mm	1150	1110	1110	1110	1110	1110	1110	1110
	H mm	863	1270	1270	1270	1270	1270	1270	1270
Dimensions	L mm	2410	3373	3373	4373	4373	4373	4373	5373
[horizontal air flow]	D mm	380	705	705	705	705	705	705	705
	H mm	1130	1040	1040	1040	1040	1040	1040	1040
Weight	kg	104	226	226	226	226	328	328	355

- Connection between INNOV@ double circuit and 2 remote low noise condensers single circuit.

Model		2 x SHVS 20/2	2 x SHVS 20/2	2 x SHVS 27/1	2 x SHVS 36/0	2 x SHVS 36/0	2 x SHVS 36/0	2 x SHVS 36/0	2 x SHVS 48/1	2 x SHVS 70 V	2 x SHVS 70 V
INNOV@	mod.	0272	0302	0362	0422	0452	0532	0592	0602	0692	0762
Nr. Of fans x Ø	mm	3 x 350	3 x 350	4 x 350	6 x 350	6 x 350	6 x 350	6 x 350	8 x 350	3 x 630	3 x 630
Air Flow	m <sup>3</sup> /h	3900	3900	5200	9000	9000	9000	9000	12000	18000	18000
Power supply	V/ph/Hz	220/1/50	220/1/50	220/1/50	220/1/50	220/1/50	220/1/50	220/1/50	220/1/50	220/1/50	220/1/50
Absorbed power	W	210	210	280	720	720	720	720	560	1125	1125
Absorbed current	A	1,0	1,0	1.32	3,4	3,4	3,4	3,4	2,6	5,1	5,1
Sound pressure level in free field	dB(A)	35	35	36	38	38	38	38	39	42	42
Dimensions in case of vertical air flow	L mm	1853	1853	1298	1853	1853	1853	1853	2408	3393	3393
	D mm	600	600	1150	1150	1150	1150	1150	1150	1110	1110
	H mm	763	763	863	863	863	863	863	863	1270	1270
Dimensions in case of horizontal air flow	L mm	1853	1853	1298	1853	1853	1853	1853	2408	3373	3373
	D mm	380	380	380	380	380	380	380	380	705	705
	H mm	570	570	1130	1130	1130	1130	1130	1130	1040	1040
Weight	kg	48	48	64	81	81	81	81	104	226	226

L= lenght, P= Depth, H= heigh

## 10. DRY COOLER TECHNICAL DATA

### a. Dry cooler – Standard Execution – SHL.

(selection related to 30°C air temperature and 45/40°C 30% e.g water conditions. Max air T = 40°C)

SHL.		SHLR 15M	SHLN 24D	SHLN 24D	SHLN 29L	SHLN 30D	SHLN 50C	SHLN 58D	SHLN 58D
<b>INNOV@ Models</b>		<b>60</b>	<b>80</b>	<b>100</b>	<b>110</b>	<b>130</b>	<b>160</b>	<b>190</b>	<b>205</b>
Power supply	V/ph/Hz	230/1/50	230/1/50	230/1/50	230/1/50	230/1/50	230/1/50	230/1/50	230/1/50
Air Flow	m3/h	2.820	6.350	6.350	6.440	7.800	12.700	12.880	12.880
Water flow	m3/h	2.1	3.6	3.6	3.9	3.9	7.2	8.1	8.1
Water pressure drop	kPa	33	35	35	23	23	28	53	53
Absorbed power	W	136	741	741	741	620	1.482	1.482	1.482
Absorbed current	A	0.60	3.30	3.30	3.30	2.80	6.60	6.60	6.60
Fans	mm	1 x 500	1 x 500	1 x 500	1 x 500	1 x 630	2 x 500	2 x 500	2 x 500
Sound pressure level in free field	dB(A)	29	47	47	47	45	50	50	50
Dimensions	L mm	1.085	1.085	1.085	1.085	1.393	1.895	1.895	1.895
(vertical airflow)	P mm	810	810	810	810	1110	810	810	810
	H mm	1.070	1.070	1.070	1.070	1.270	1.070	1.070	1.070
Dimensions	L mm	1.085	1.085	1.085	1.085	1.393	1.895	1.895	1.895
(horizontal air flow)	P mm	470	470	470	470	705	470	470	470
	H mm	830	830	830	830	1.040	830	830	830
Weight	kg	56	56	56	60	123	94	102	102

SHLN		58 D	73 C	73 C	83 C	110 D	73 C	83 C
<b>INNOV@ models</b>	Mod.	<b>0201</b>	<b>0251</b>	<b>0281</b>	<b>0311</b>	<b>0401</b>	<b>0272</b>	<b>0302</b>
Power supply	V/Ph/Hz	220/1/50	220/1/50	220/1/50	220/1/50	220/1/50	220/1/50	220/1/50
Air flow	m3/h	12880	19050	19050	19320	25760	19050	19320
Absorbed power	W	1482	2230	2230	2230	2970	2230	2230
Absorbed current	A	6.6	9.9	9.9	9.9	13.2	9.9	9.9
Fans	Nr.	2	3	3	3	4	3	3
	mm	500	500	500	500	500	500	500
Sound pressure level in f.f.	dB(A)	50	51	51	51	53	51	51
Dimensions	L mm	1895	2705	2705	2705	1895	2705	2705
[vertical air flow]	D mm	810	810	810	810	1625	810	810
	H mm	1070	1070	1070	1070	1070	1070	1070
Dimensions	L mm	1895	2705	2705	2705	1895	2705	2705
[horizontal air flow]	D mm	470	470	470	470	470	470	470
	H mm	830	830	830	830	1645	830	830
Weight	kg	102	132	132	144	190	132	144

SHLN		98 C	110 D	118 F	147 C	147 C	182 C	182 C	208 B
<b>INNOV@ models</b>	Mod.	<b>0362</b>	<b>0422</b>	<b>0452</b>	<b>0532</b>	<b>0592</b>	<b>0602</b>	<b>0692</b>	<b>0762</b>
Power supply	V/Ph/Hz	220/1/50	220/1/50	220/1/50	220/1/50	220/1/50	220/1/50	220/1/50	220/1/50
Air flow	m3/h	25760	25760	31200	38100	38100	46800	46800	66400
Absorbed power	W	2970	2970	2480	4450	4450	3720	3720	4960
Absorbed current	A	13.2	13.2	11.2	19.8	19.8	16.8	16.8	22.4
Fans	Nr.	4	4	4	6	6	6	6	8
	mm	500	500	630	500	500	630	630	630
Sound pressure level in f.f.	dB(A)	53	53	50	54	54	52	52	53
Dimensions	L mm	1895	1895	4676	2705	2705	3393	3393	4393
[vertical air flow]	D mm	1625	1625	1110	1625	1625	2120	2120	2120
	H mm	1070	1070	1270	1070	1070	1270	1270	1270
Dimensions	L mm	1895	1895	4676	2705	2705	3393	3393	4393
[horizontal air flow]	D mm	470	470	710	470	470	990	990	990
	H mm	1645	1645	1040	830	830	2120	2120	2120
Weight	kg	174	190	328	288	288	522	449	522

**b. Dry cooler – Low Noise Execution – SHLS**

(selection related to 30°C air temperature and 45/40°C 30% e.g water conditions. Max air T = 40°C)

Model		SHLR 15M	SHLS 19M	SHLS 19M	SHLS 38D	SHLS 38D	SHLS 38D	SHLS 59D	SHLS 59D
<b>INNOV@ Models</b>		<b>0060</b>	<b>0080</b>	<b>0100</b>	<b>0110</b>	<b>0130</b>	<b>0160</b>	<b>0190</b>	<b>0205</b>
Power supply	V/ph/Hz	230/1/50	230/1/50	230/1/50	230/1/50	230/1/50	230/1/50	230/1/50	230/1/50
Air Flow	m3/h	2.820	4.500	4.500	8.300	8.300	8.300	12.400	12.400
Water flow	m3/h	2.1	2.8	2.8	5.7	5.7	5.7	8.5	8.5
Water pressure	kPa	33	57	57	51	51	51	46	46
Absorbed power	W	136	272	272	544	544	544	816	816
Absorbed current	A	0.60	2.80	2.80	2.40	2.40	2.40	3.60	3.60
Fans	mm	1 x 500	1 x 500	1 x 500	2 x 500	2 x 500	2 x 500	3 x 500	3 x 500
Sound pressure level f.f.	dB(A)	29	38	38	41	41	41	42	42
Dimensions	L mm	1.085	1.085	1.085	1.895	1.895	1.895	2.705	2.705
(vertical airflow)	P mm	810	810	810	810	810	810	810	810
	H mm	1.070	1.070	1.070	1.070	1.070	1.070	1.070	1.070
Dimensions	L mm	1.085	1.085	1.085	1.895	1.895	1.895	2.705	2.705
(horizontal air flow)	P mm	470	470	470	470	470	470	470	470
	H mm	830	830	830	830	830	830	830	830
Weight	kg	56	56	56	94	94	94	132	132

SHLS		59 C	72 C	72 C	87 D	114 D	72 C	87 D
<b>INNOV@ models</b>	Mod.	<b>0201</b>	<b>0251</b>	<b>0281</b>	<b>0311</b>	<b>0401</b>	<b>0272</b>	<b>0302</b>
Power supply	V/Ph/Hz	220/1/50	220/1/50	220/1/50	220/1/50	220/1/50	220/1/50	220/1/50
Air flow	m3/h	12400	16800	16800	24000	24820	16800	24000
Absorbed power	W	816	1125	1125	1500	1640	1125	1500
Absorbed current	A	3.6	5.1	5.1	6.8	7.3	5.1	6.8
Fans	Nr.	3	3	3	4	6	3	4
	mm	500	630	630	630	500	630	630
Sound pressure level in f.f.	dB(A)	42	42	42	43	44	42	43
Dimensions	L mm	2710	3393	3393	4393	2710	3393	4393
[vertical air flow]	D mm	810	1110	1110	1110	1625	1110	1110
	H mm	1070	1270	1270	1270	1070	1270	1270
Dimensions	L mm	2710	3393	3393	4393	2710	3393	4393
[horizontal air flow]	D mm	470	990	990	990	470	990	990
	H mm	830	1040	1040	1040	1645	1040	1040
Weight	kg	132	251	251	298	250	251	298

SHLS		97 C	114 D	117 B	141 C	141 C	173 B	188 B	213 B
<b>INNOV@ models</b>	Mod.	<b>0362</b>	<b>0422</b>	<b>0452</b>	<b>0532</b>	<b>0592</b>	<b>0602</b>	<b>0692</b>	<b>0762</b>
Power supply	V/Ph/Hz	220/1/50	220/1/50	220/1/50	220/1/50	220/1/50	220/1/50	220/1/50	220/1/50
Air flow	m3/h	22400	24820	28000	33600	33600	48000	44800	60000
Absorbed power	W	1500	1640	1875	2250	2250	3000	3000	3750
Absorbed current	A	6.8	7.3	8.5	10.2	10.2	13.6	13.6	17.0
Fans	Nr.	4	6	5	6	6	8	8	10
	mm	630	500	630	630	630	630	630	630
Sound pressure level in f.f.	dB(A)	43	44	44	45	45	46	46	46
Dimensions	L mm	4393	2710	5393	3393	3393	4393	4393	5393
[vertical air flow]	D mm	1110	1625	1110	2120	2120	2120	2120	2120
	H mm	1270	1070	1270	1270	1270	1270	1270	1270
Dimensions	L mm	4393	2710	5393	3393	3393	4393	4393	5393
[horizontal air flow]	D mm	990	470	990	990	990	990	990	990
	H mm	1040	1645	1040	2120	2120	2120	2120	2120
Weight	kg	328	250	390	450	450	522	582	629

## 11. CORRECTION FACTORS

### DX Units- Air Cooled

#### Cooling Capacity

		T <sub>amb</sub> [°C] (*)				
		20	22	24	26	28
Test [°C]	25	0,97	1,04	1,13	1,19	1,30
	30	0,91	0,98	1,07	1,13	1,23
	35	0,85	0,91	1,00	1,05	1,15
	40	0,79	0,85	0,93	0,98	1,08
	45	0,72	0,78	0,85	0,90	0,99

(\*) R.h. 50%

#### Absorbed Power

		T <sub>amb</sub> [°C] (*)				
		20	22	24	26	28
Test [°C]	25	0,809	0,804	0,795	0,789	0,774
	30	0,906	0,900	0,891	0,886	0,874
	35	1,015	1,009	1,000	0,997	0,985
	40	1,135	1,132	1,123	1,120	1,111
	45	1,279	1,276	1,270	1,267	1,258

(\*) R.h. 50%

#### Absorbed Current

		T <sub>amb</sub> [°C] (*)				
		20	22	24	26	28
Test [°C]	25	0,878	0,873	0,866	0,863	0,855
	30	0,939	0,936	0,929	0,926	0,919
	35	1,008	1,005	1,000	0,997	0,990
	40	1,087	1,084	1,079	1,076	1,071
	45	1,179	1,177	1,174	1,171	1,166

(\*) R.h. 50%

### DX Units - Water Cooled

#### Cooling Capacity

		T <sub>amb</sub> [°C] (*)				
		20	22	24	26	28
T <sub>H2O-in</sub> [°C]	15	0,86	0,92	1,00	1,05	1,15

(\*) R.h. 50%

#### Absorbed Power

		T <sub>amb</sub> [°C] (*)				
		20	22	24	26	28
T <sub>H2O-in</sub> [°C]	15	1,017	1,010	1,00	0,990	0,976

(\*) R.h. 50%

#### Absorbed Current

		T <sub>amb</sub> [°C] (*)				
		20	22	24	26	28
T <sub>H2O-in</sub> [°C]	15	1,013	1,007	1,00	0,995	0,986

(\*) R.h. 50%

### Chiller water units

#### Cooling Capacity

		T <sub>amb</sub> [°C] (*)						
		20	22	24	26	28		
T <sub>H2O-in</sub> [°C]	7	T <sub>H2O-out</sub> [°C]	12	0,680	0,817	1,00	1,159	1,360
	8		13	0,629	0,731	0,881	1,076	1,282
	10		15	0,524	0,628	0,729	0,897	1,104

(\*) R.h. 50%

## 12. REFRIGERANT PIPES

On site piping has to be installed by professional workers using only CUB quality copper pipes. Take care in use of nitrogen during all brazing operations in order to avoid humidity and dirty in pipes.

Refrigerant		R407C	R407C	R407C	R407C	R407C	R407C	R407C	R407C	R407C	R407C	R407C
<b>Cooling Capacity</b>	[kW]	4-5	6-7	8-9	10-11.5	11.5-13	14-16	17-18	19-24	25-29	30-34	35-40
<b>HP Gas line 0-10m</b>	[mm]	12	12	12	16	16	16	16	22	22	22	28
<b>Liquid line 0-10m</b>	[mm]	10	10	10	12	12	12	12	16	16	16	18
<b>HP Gas line 11-20m</b>	[mm]	12	12	16	16	16	18	18	22	22	28	28
<b>Liquid line 11-20m</b>	[mm]	10	10	12	12	12	12	12	16	16	18	18

### Standard Copper pipes

Diameter [mm]	Thickness [mm]	Minimum bending radius [mm]	System design pressurePS [bar]	PED Category	Max Copper $\sigma_s$ [N/mm <sup>2</sup> ]	Real copper $\sigma$ [N/mm <sup>2</sup> ]	Safety ratio
10	1	36	28	A3 P3	227	11.2	20.3
12	1	36	28	A3 P3	227	14	16.2
16	1	46	28	A3 P3	227	19.6	11.6
18	1	56	28	A3 P3	227	21	10.8
22	1,5	67	28	A3 P3	227	17.3	13.1
28	1,5	96	28	A3 P3	227	23.3	9.8
35	1.5	70	28	A3P3	227	29.8	7.6
42	1.5	84	28	A3P3	227	36.4	6.2
54	2.0	108	28	A3P3	227	35	6.4



### 13. INTERCONNECTIVITY SYSTEMS

#### Advanced Control pCO - Local Area Network (LAN)

Remote Display

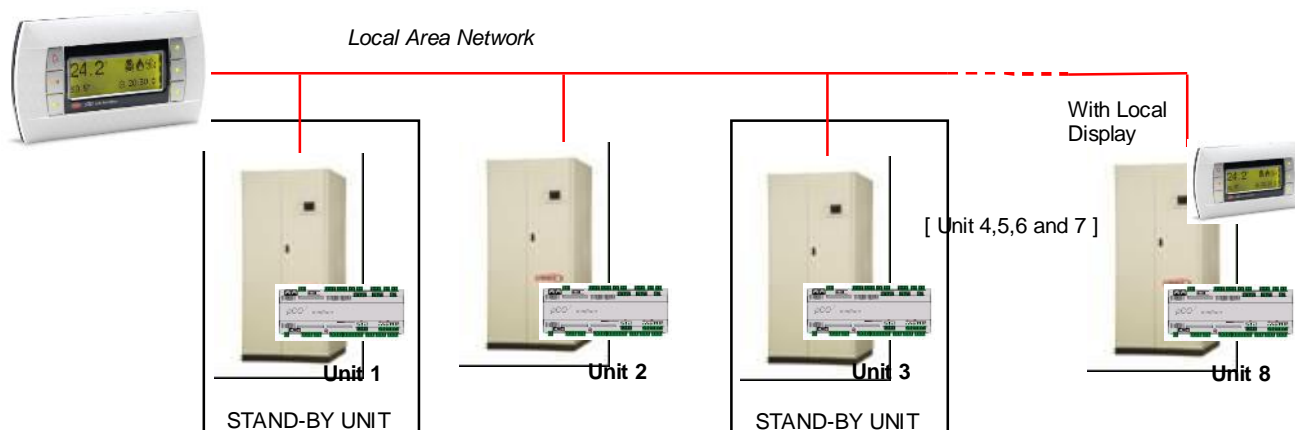

**Description:**

**Stand-by rotation:**

- Max. Number of units: 8
- Stand-by rotation of 1 to N unit (N is the number of installed unit).
- Stand-by rotation activated by timing, time band or by alarm

**Master function:**

The “Master” unit’s temperature and humidity probes must be located in an “intermediate” position inside the controlled environment. The “Master” unit drives the logic that is adopted by every connected unit. This is important to avoid situations in which units in dehumidification and units in humidification contra-work at the same time in the same environment. The “Master” unit changes the working logic in case of exceeding the set point by the measured temperature or humidity, even of just a few decimal points. In case of black-out or of disconnection of the “Master” unit from the pLAN network, the connected units will start to operate stand-alone based just on the their own probes.

#### DATAWEB Supervising Systems

The system allows air-conditioning to be monitored and controlled using just a simple Internet browser: the pages displayed on the PC are in HTML format, the language of the worldwide web.

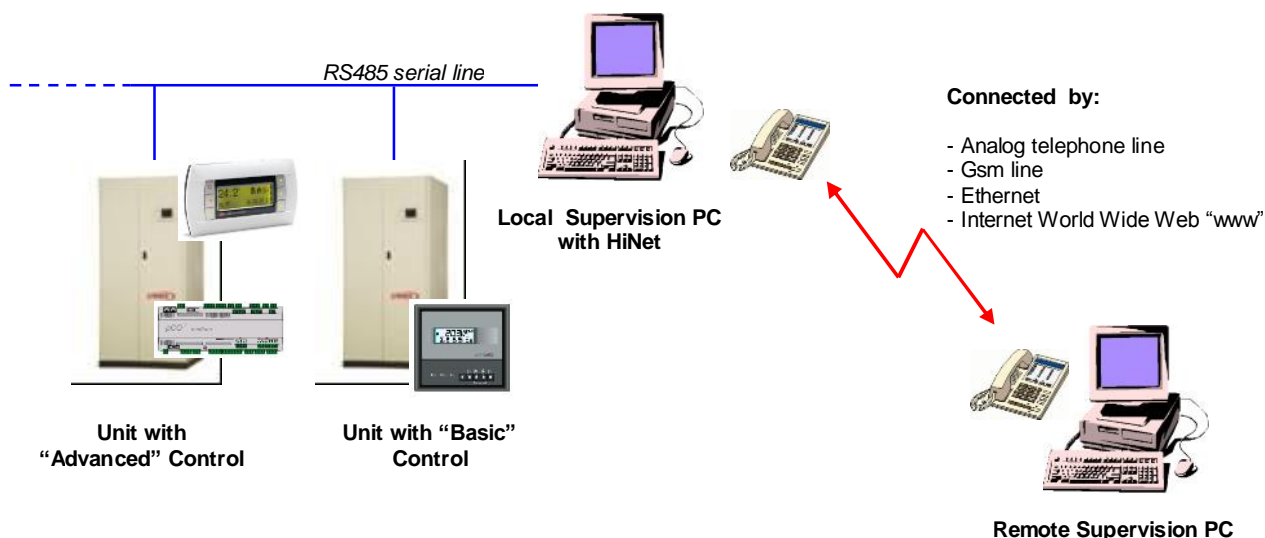

### BMS integration

INNOV@ units can be connected to BMS in the following ways:

- Directly, without using a gateway, thanks to the ability of the advanced control pCO to select the protocol used;

- using a gateway that translates the Carel proprietary protocol to the specific BMS protocol;
- integrating the driver for the management of the Carel specific protocol into the BMS.

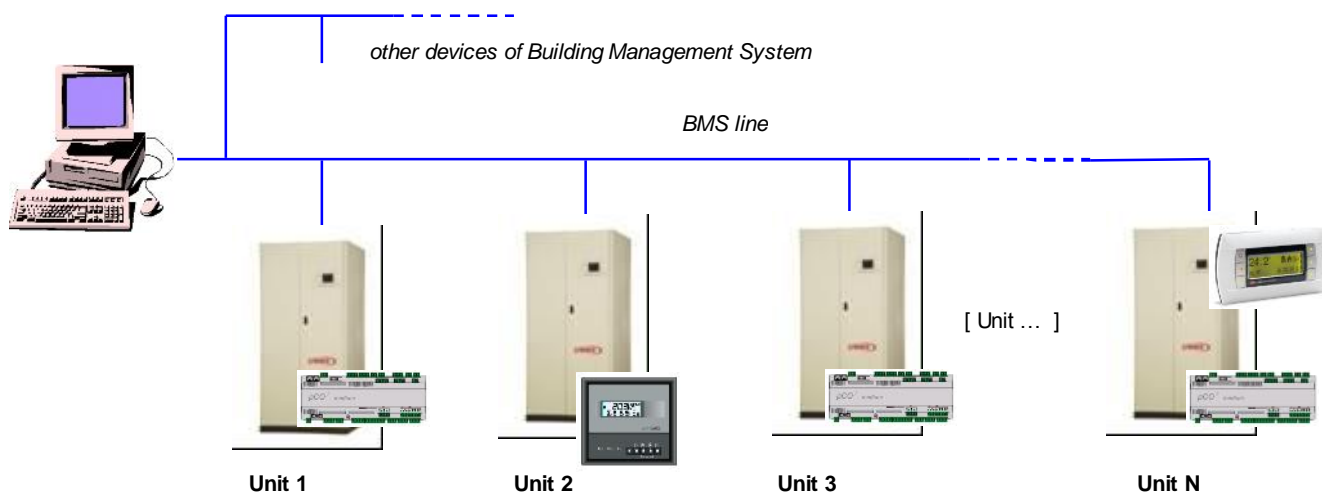

Following Serial port / protocols are used by LENNOX to ensure connectivity to the other systems:

With advanced microprocessor:

- o RS485 / Carel o Modbus® ;
- o Modem GSM + RS 232 / sms (units status advice by sms in case of alarm);
- o LonWorks® FTT-10 card / LonWorks®

- o pCOWeb Ethernet connection / BACnet™ o SNMP (TCP-IP)
- o pCOWeb RS485 connector / BACnet™
- o TREND® serial card / TREND®

With basic microprocessor:

- o RS485 / Carel
- o External Modbus® gateway / Modbus®

**pGD3 Graphical touch screen color display (panel mounted)**

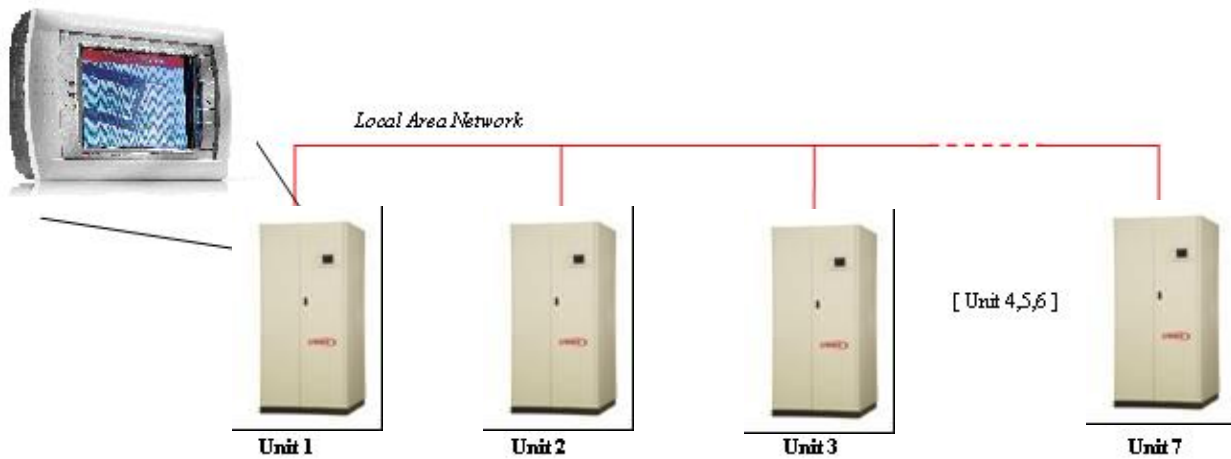

The pGD3 display can show:

- Temperature trend graphics of the single unit or the average value between all the units connected on the LAN.
- Humidity trend graphics of the single unit or the average value between all the units connected on the LAN.

**Note:**

- With pGD3 display, at most 7 units can be connected on a LAN
- Inside the electrical panel of all the units connected, a pGD0 display is installed; this allows the unit to manage when it is disconnected from the LAN and for the advanced configuration.

**pCOWeb Interface card for BACnet/SNMP with Ethernet RJ45 connection**

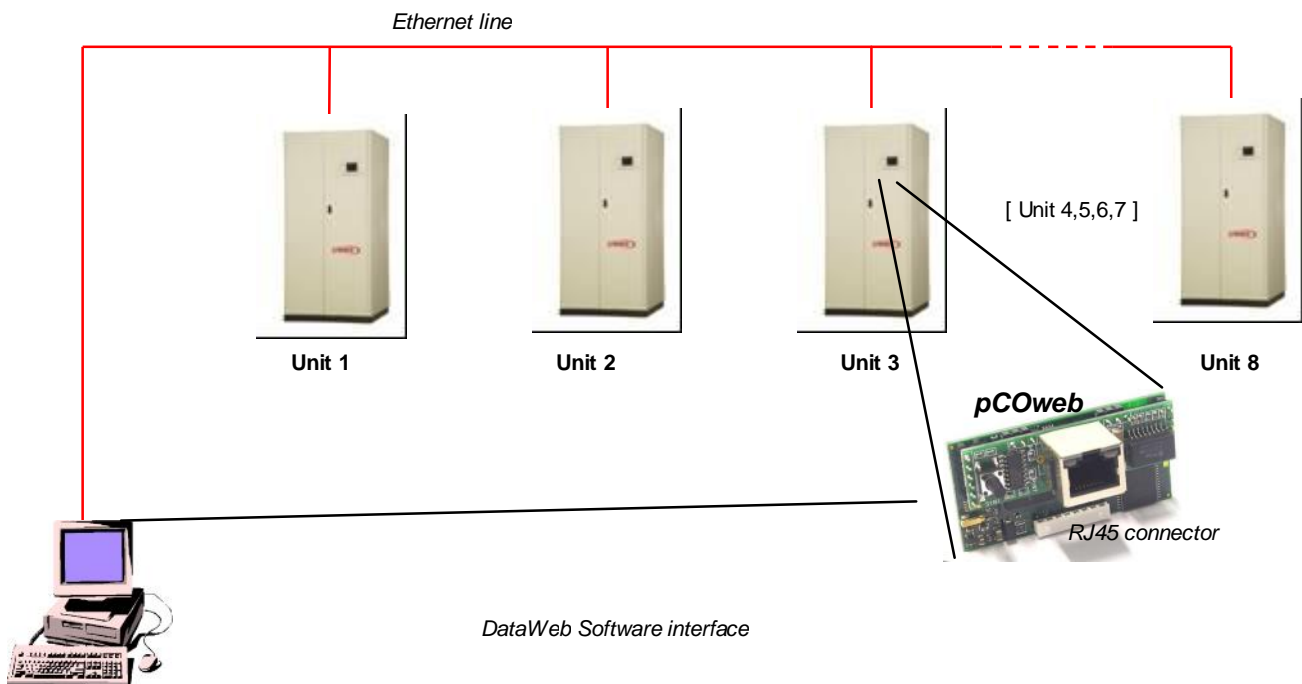

The pCOWeb Ethernet connection function are:

**a) Only hardware**

*Hardware requirements:*

- pCOWeb interface card

*Functions:*

- BACnet protocol converter
- SNMP protocol converter
- Data logging of a maximum of 10 variables and download of the data via FTP
- Sending of an email in case of alarms using an external mail server

**b) Complete solution**

*Software requirements :*

- DataWeb for pCOWeb (option)

*Hardware requirements:*

- pCOWeb interface card

*Functions:*

- Reading the status of the units
- Modification of the parameter of the units
- Data logging of a maximum of 10 variables and download of the data via FTP
- Sending of an email in case of alarms using an external mail serve





[www.lennox europe.com](http://www.lennox europe.com)

**BELGIUM, LUXEMBOURG**  
[www.lennoxbelgium.com](http://www.lennoxbelgium.com)

**CZECH REPUBLIC**  
[www.lennox czech.com](http://www.lennox czech.com)

**FRANCE**  
[www.lennoxfrance.com](http://www.lennoxfrance.com)

**GERMANY**  
[www.lennox deutschland.com](http://www.lennox deutschland.com)

**NETHERLANDS**  
[www.lennox nederland.com](http://www.lennox nederland.com)

**POLAND**  
[www.lennox polska.com](http://www.lennox polska.com)

**PORTUGAL**  
[www.lennoxportugal.com](http://www.lennoxportugal.com)

**RUSSIA**  
[www.lennoxrussia.com](http://www.lennoxrussia.com)

**SLOVAKIA**  
[www.lennox distribution.com](http://www.lennox distribution.com)

**SPAIN**  
[www.lennoxspain.com](http://www.lennoxspain.com)

**UKRAINE**  
[www.lennoxukraine.com](http://www.lennoxukraine.com)

**UNITED KINGDOM AND IRELAND**  
[www.lennoxuk.com](http://www.lennoxuk.com)

**OTHER COUNTRIES**  
[www.lennox distribution.com](http://www.lennox distribution.com)

Due to Lennox's ongoing commitment to quality, the Specifications, Ratings and Dimensions are subject to change without notice and without incurring liability.

Improper installation, adjustment, alteration, service or maintenance can cause property damage or personal injury.

Installation and service must be performed by a qualified installer and servicing agency.

