

Application guide @DNOVA - THS



- Providing indoor climate comfort



Index AGU



Introduction	2
Features and Fortes	3
Configuration DIGIT	6
Manufacturing Specifications	7
Control Software and Hardware	10
List of the Main Options	11
Tests and Reference Standards	13
Technical Data	14
Dimensional Drawings	15
Refrigerant Circuit	21

Our products comply with the European standards.



LENNOX have been providing environmental solutions since 1895, our range of @DNOVA units continues to meet the standards that have made LENNOX a household name. Flexible design solutions to meet YOUR needs and uncompromising attention to detail. Engineered to last, simple to maintain and Quality that comes as standard. Information on local contacts at www.lennox europe.com.

All the technical and technological information contained in this manual, including any drawing and technical descriptions provided by us, remain the property of Lennox and must not be utilised (except in operation of this product), reproduced, issued to or made available to third parties without the prior written agreement of Lennox.

Due to LENNOX on going commitment to quality, specifications subject to change without notice and without incurring liability

THS "LENNOX Telecom Split units" composed by an evaporating indoor unit **THI** for ceiling and a motor-condensing outdoor unit **THC**, mainly for electronic equipped shelters, process centres and telecommunications sites.

Proposed in 9 models with nominal cooling capacity from 2,60 to 14,50 kW. The system provides air filtration, indoor ventilation, cooling, heating, freecooling with outdoor fresh air to assure the useful climate in the site.

The unit can accept emergency power supply of 48VDC for assuring indoor ventilation and Freecooling. THI evaporating unit are designed to be mounted in ceiling inside shelters.

Structure

All THS units supporting structure are made of galvanized sheet steel of suitable thickness, duly insulated with noise-proof/anti-condensing material, self-extinguishing in Class 1.

The enclosing panels are painted with epoxy polyester powder coating cured at 180 °C or, on request, painted galvanised sheet steel (RAL 9002).

It is featured by rounded shape edges, according to innovative style trends and the accident prevention.

All structure details are entirely produced in-house with automatic processes integrating the CAD-3D designing (solid modeller) with the production process

(CAM) = CAD-CAM.

Power supplies

All units are available with different supply voltages, with the option of double power supply. In this case it is possible to have a 48VDC solution for the air-conditioning control, even in case of power failure.

European directives

The **THS** units are designed and manufactured according to the European directives currently in force, and are consequently marked CE.

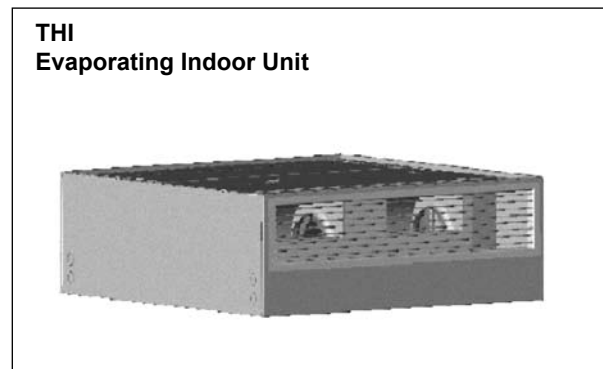
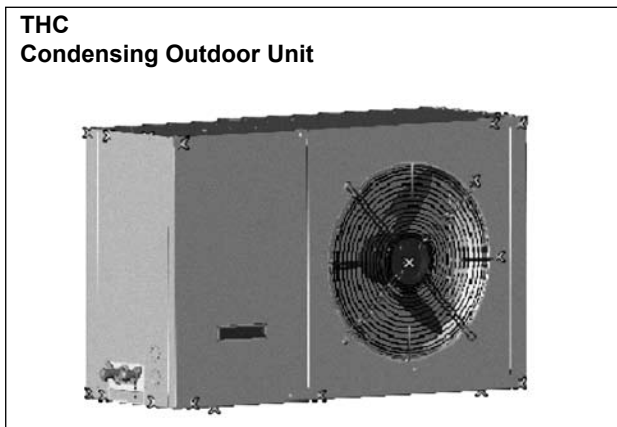

Design & Technology

The **THS** units introduce a rational arrangement of the components and an excellent assembly compactness. All units are factory tested by using automatic systems based on objective "in-out" criteria and are ready to be installed and started by simple wiring on site.

Installation

The **THS** packaged split air-conditioning unit is suitable for all environments except aggressive ones. Make sure that the **THI** indoor unit have more than 0,2 m free space around (Service area). Do not place any obstacles near the unit and make sure that the air flow is not impeded by obstacles and/or situations causing back suction (see Fig. 1). The recommended sizes for the power cables and emergency line are shown in Tab.1.

Handling

While the unit is being unloaded and positioned, utmost care must be taken to avoid abrupt or violent manoeuvres. The unit must be handled carefully and gently; avoid using machine components as anchorages or holds and always keep it in an upright position. The unit should be lifted using the pallet it is packed on; a transpallet or similar conveyance means should be used.

Packing / Unpacking

The standard packing consist of a wooden pallet and cardboard box, and a polythene foam protects the units' painted surface. On request, a cardboard box with an additional wooden crate or wooden case for sea transport can be supplied. The packing must be carefully removed to avoid the risk of damaging the unit. Different packing materials are used : wood, cardboard, nylon etc. It is recommended to keep them separately and deliver them to suitable waste disposal or recycling facilities in order to minimise their environmental impact.

Noise levels

The **THS** units include the exclusive use of ventilation solutions, featured by a low emitted noise level making these conditioners compatible with city installations. The support structure, the panels and the fastening systems are designed to reduce vibrations and their transmission as low frequency sound emissions as much as possible.

Energy efficiency

The highest possible energy efficiency has been the main target in the whole thermo-dynamic and aeraulic designing. The refrigerating circuit is featured by the use of rotary (**THC** 025-035-045) or Scroll (**THC** 056 - 073 - 090 - 105 - 120 - 145) compressors with top reliability and (optional) possibility of replacing the traditional with an electronically - controlled electric valve : this brings a reduced energy consumption by 50% when the outer temperature lowers below 20°C and, above all, when the direct free-cooling is not possible. The aeraulic circuit implies the use of centrifugal fans with forwardly curved blades, featured by a very high reaction degree, it is thus possible to remove the scroll and the relevant energy losses in the dynamic-static conversion; all used fans can be equipped with "brushless" motor with permanent magnets and relevant switching electronics, that can be directly powered by an emergency mains at 48VDC. In this case, the DC motor efficiency matches with the fan efficiency, thus reaching outstanding energy results (over 45%). The Freecooling in simultaneous operation contributes remarkably to reduce energy costs in the range of outer temperatures between the inner set point and TFT (Total Free-Cooling Temperature).

Emergency situations

All units can be equipped with dual supply : main supply and "DC" supply.

- Main supply :
 - Compressor
 - Heating
 - Condensing section fan
- 48VDC emergency supply:
 - evaporating section fan
 - Microprocessor
 - Damper servomotor

In case of mains failure, a voltage presence relay signals this to the "mP" control that, together with the ventilation and Free-Cooling section, continues to be powered by back-up batteries. This ensures the air-conditioning control even with possible inner temperature variations from the set-point values.

Manufacturing features

All electric, aeraulic and refrigerating components are assembled inside the machine cabinet and cannot be accessed from outside, without removing the panels. The machine has a min. protection degree IP 44 and the protection grilles of the rotary parts comply with the accident prevention section of the norms EN 60335. **THC** outdoor unit positioning The condensing unit must be positioned outside to enable its cooling. It is connected to the air conditioner through the refrigerant lines. Keep refrigerant lines as short as possible (do not use lines longer than 15m for R22 and 10m for R407C).

THI indoor unit positioning

Bear in mind the following aspects when choosing the best site for installing the unit and the relative connections :

- position the indoor unit **THI** next to the main heat source;
- location of power supply;
- solidity of the supporting ceiling.

It is recommended to first prepare holes in the ceiling for the screw anchors. The dimensions and the positions of the holes for the screw anchors are shown in Fig. 2.

Fig. 1 - Service Area (top view)

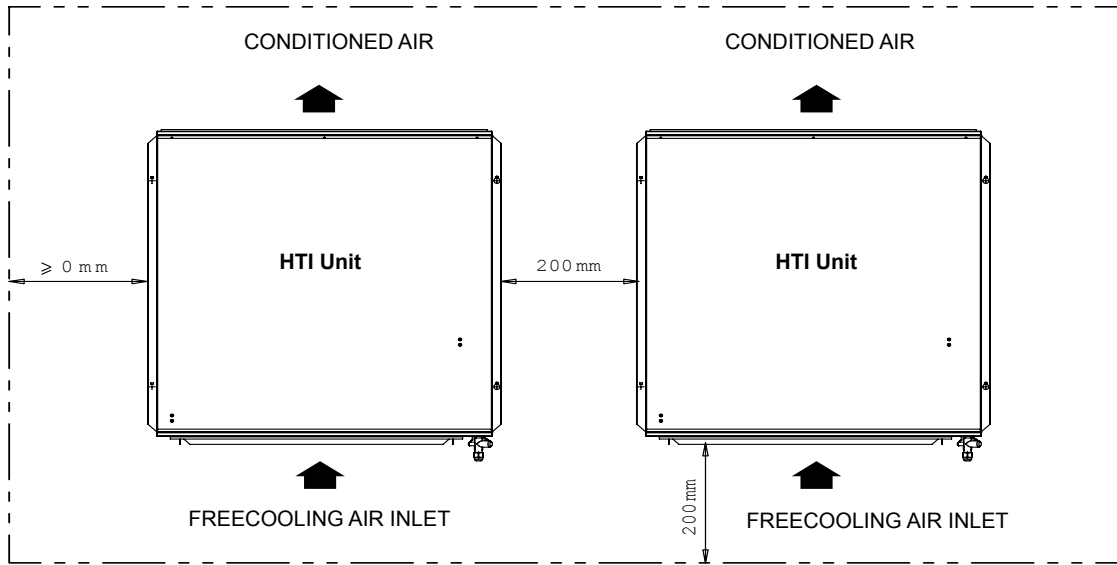
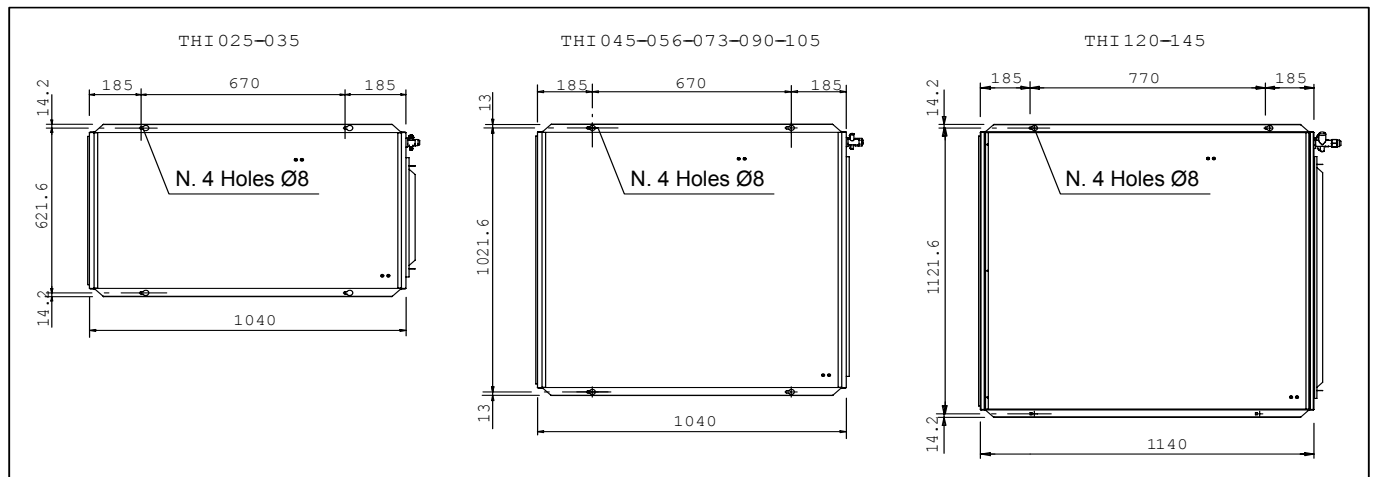

Fig. 1 - Holes position (top view)



Tab.1 - THI cable sizes

UNIT MODEL	MAINS POWER SUPPLY	CABLE TYPE	UPS EMERGENCY LINE	CABLE TYPE
THI 025				
THI 035				
THI 045				
THI 056				
THI 073				
THI 090	230 V / 1 Ph / 50 Hz	2x6 mm ² + T x 6 mm ²	48 VDC	2 x 2,5 mm ²
THI 105				
THI 120				
THI 145				

Tab.2 - THC cable sizes

UNIT MODEL	MAINS POWER SUPPLY	CABLE TYPE	UPS EMERGENCY LINE	CABLE TYPE
THI 025				
THI 035				
THI 045				
THI 056	230 V / 1 Ph / 50 Hz	2x6 mm ² + T x 6 mm ²	48 VDC	2 x 2,5 mm ²
THI 073				
THI 090				
THI 105				
THI 120	400 V / 3 Ph + N / 50 Hz	4x6 mm ² + T x 6 mm ²	48 VDC	2 x 4,0 mm ²
THI 145				

DX Direct Expansion Unit

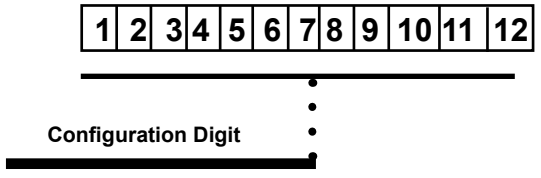
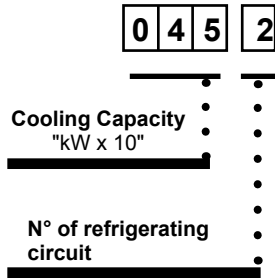
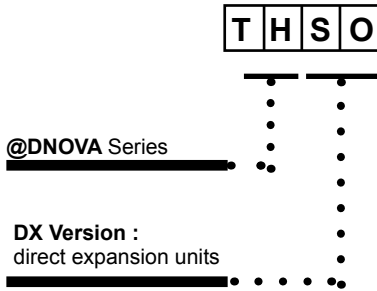

1 SUPPLY (+ Auxiliary)	0	230V / 1Ph / 50Hz
	2	230V / 1Ph / 50Hz + [48VDC]
	4	400V / 3Ph + N / 50Hz
	6	400V / 3Ph + N / 50Hz + [48VDC]
2 CONTROL	C	ADVANCED [display built-in]
	D	ADVANCED [without local user interface]
3 REFRIGERANT CYCLE OPTIONS	0	R407C
	1	R407C + electronic thermal expansion valve
	2	R22
	3	R22 + electronic thermal expansion valve
4 CABINET OPTION	E	Paintless galvanized sheet RAL 7035
5 ELECTRIC RE-HEATING	0	Heaters - NO
	1	Heaters - YES
6 FREE-COOLING	0	Without free-cooling
	G	Modulating Free-cooling 0 - 10V
	H	Free-cooling with spring return
7 AIR FILTRATION	0	G2 Filter (STANDARD)
	1	G3 Filter
	2	G4 Filter
	7	G2 Filter + Clogged filter sensor
	8	G3 Filter + Clogged filter sensor
8 CONDENSATION CONTROL	0	None
	C	On / Off
	E	Modulating fan speed (with pressure sensor)
9 SERIAL COMMUNICATION	0	None
	1	Serial Card RS232 Modem
10 Coils	2	Serial Card RS485
	0	Copper tubes / alu fins (Standard)
11 PACKAGING	1	Epoxy coated condenser coil
	2	Epoxy coated evaporator coil
12 SPECIAL	0	STANDARD
	1	Wooden Crate with cardboard
	2	Seaworthy
	0	STANDARD

THC Condensing unit

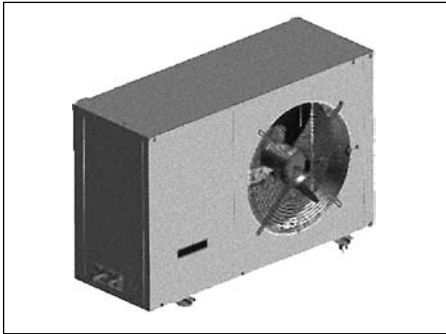

Refrigerating circuit

The refrigerating circuit is entirely in house manufactured, using welders certified according to the Directive PED 97/23 on pressurized containers, and all relevant components are certified according to the same directive. The exclusive rotary or scroll-type used compressors are available in the version for fluids type HFC R407C; for the non-EEC countries signing the Montreal Protocol, in the version with HCFC R22.



The machine standard equipment includes a thermostatic lamination valve and a vacuum start device: this device is enclosed in the Scroll compressor or is outside in the versions with single-phase rotary compressor/s. The circuit is completed with anti-acid dryer filter with molecular sieve, a flow indicator and pressure intakes for the maintenance and/or inspection operations. The compressor is also equipped with two pressure switches for protection against high condensing (HP) and low evaporating (LP) pressures. The LP switch features automatic reset and the HP switch is equipped, for safety reasons, with manual reset.

Condenser with finned pack

With geometry 25x21.65 and a 3/8. pipe it is composed of 0.10-mm thick aluminium fins and copper pipes expanded on the same for a complete contact. The design criteria privileges the front section with the advantage of reduced losses on the air side, so that it is possible to use 6-pole axial fan/s with minimized emitted sound power.

Condensing fan section

The unit is equipped with 6-pole axial fan/s and the electrical motor/s is directly coupled on the motor shaft, with internal thermal protection on IP44. This kind of motors limit the sound emissions, and are outer rotor type to improve the energy efficiency and reduce themagnetic noise.

THI Evaporating unit

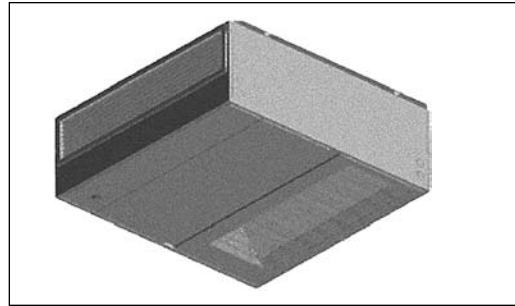

Finned pack evaporator

The heat transfer coil consists of a slab coil in copper tubes with aluminium waved fins with a large face area so as to increase the SHR (Sensible Heat Ratio) and also optimise the EER (Energy Efficiency Ratio). This is achieved by reducing the air pressure drop and turbulence and increasing the evaporating temperature, thus the efficiency of the compressor.

Evaporating fan section

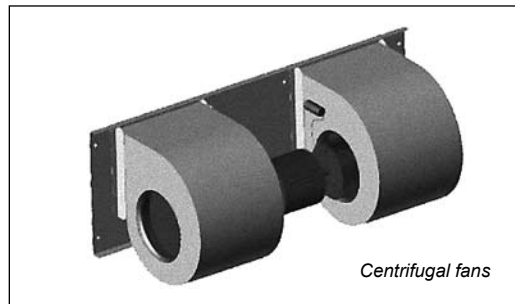

The standard THI units are supplied with centrifugal fans with forwardly curved blades impeller. These fans have been specifically conceived for combine small size with high flow rate. All machines can be equipped with fans powered by brushless motors with permanent magnets, DC supplied at 48V.

Air filtration

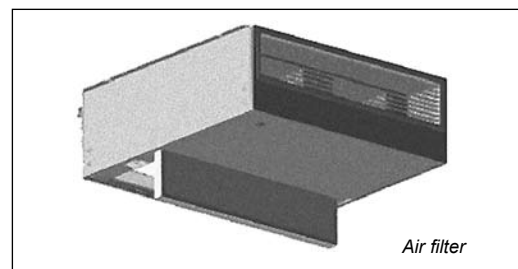

The filter is located vertically, before the evaporating coil and provides filtration of the recirculated or the fresh air to obtain the required degree of air cleaning in the room. The filter can be easily extracted by removing the bottom panel dedicated to the filter/damper section. The standard filter class is G3, according to Eurovent G4/5 standard.

Electric control board

The electric control board is constructed and wired in accordance with Directives 73/23/EEC and 89/336/EEC and related standards. All the remote controls use 24VDC signals powered by an insulating transformer.

Note :

The mechanical safety devices such as the high pressure switch are of the kind that trigger directly; their efficiency will not be affected by any faults occurring in the microprocessor control circuit, in compliance with 97/23 PED.

All on-board systems comply with the EEC Directive .Low tension 73/23. and with the related norms. The access to the electric board is possible with operating unit as it is completely separated from the air flow; the protection degree with open panel is IP20.

Tab.3 — Field of applications

MODEL: THS			025	035	045	056	073	090	105	120	145
Power supply	V/Ph/F		230VAC +/-10%/ 1Ph / 50Hz				400VAC +/-10%/ 3Ph / 50Hz				
			24VDC / 48VDC +/-16% [Emergency cooling]								
Outdoor temperature	Min.	°C	- 20°C								
	Max.		-	-	48	46,5	45	47	45	44	-
Temperature	Min.	°C/RH	19°C / 30% R.H.								
Humidity conditions	Max.		35°C / 50% R.H.								
Storage conditions	Min.	°C/RH	10°C / 90% R.H.								
	Max.		55°C / 90% R.H.								

Interconnectivity

All units can be connected with remote supervision systems by the use of "Gateway". With "mP" control of the "ADVANCED" type, there is the possibility of piloting directly a GSM modem able to send and receive SMS messages. Up to max. 15 units can

be connected with ADVANCED type mP, sharing the operating parameters and enabling the stand-by rotation and re-start of the installed machines. The interconnection possibilities, according to control type, are summarized in the tables below (Tab.4).

Tab.4 — mP ADVANCED

PROTOCOL	SERIAL CARD	GATEWAY	NOTES
		Not necessary	RS485 network connection
Proprietary Carel	RS485	RS485 / RS232 converter (PC485KIT)	Connection with the supervision PC
Modbus®	RS485	Not necessary	RS485 network connection
BACnet™	RS485	Gateway BACnet™	RS485 network connection
LonWorks®	LON RS485	Not necessary	For the dedicated programming, contact LENNOX
Trend	Trend serial	Not necessary	For the dedicated programming, contact LENNOX
Tcp/Ip	RS485	Gateway TCP/IP	Ethernet network connection
GSM	RS232	GSM modem	For the dedicated programming, contact LENNOX
	RS485 control local network	PlantWatch + GSM modem	PlantWatch operates as concentrator

Freecooling section (Option)

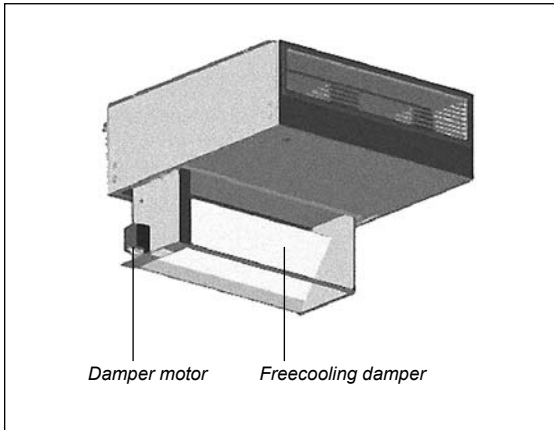

All THi units can be available with the freecooling option, in this way we save energy and achieve better reliability, for the lower number of compressor starts/stops, and the shorter running time. The freecooling section is located inside the evaporating unit, an internal motorized damper modulates his position from 0% to 100% of fresh air to achieve the required cooling capacity. The exhaust air is discharged outdoor. The consensus to freecooling is given when the difference between the indoor and outdoor air temperature is higher than a set value. No freecooling and direct expansion cooling are allowed at the same time.

Freecooling duct connections (option)

The freecooling unit is equipped with connections collect the outside air, as follows :

- Standard: double circular holes for 252mm diameter flexible ducts.
- Option: single rectangular hole with flange for 789x252mm duct.

In both cases, the holes in the wall have to be protected by rainproof grilles with prefilter to avoid water or foreign bodies get in the conditioner. Outside air, taken into the room by the fan, gets out through an overpressure damper, which is installed on the wall of the room and is protected also by external rainproof grille.

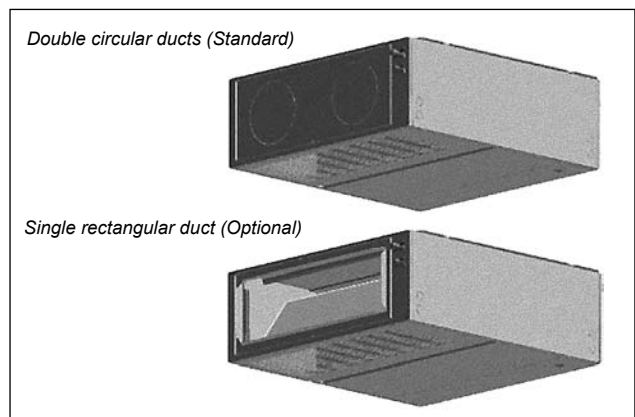
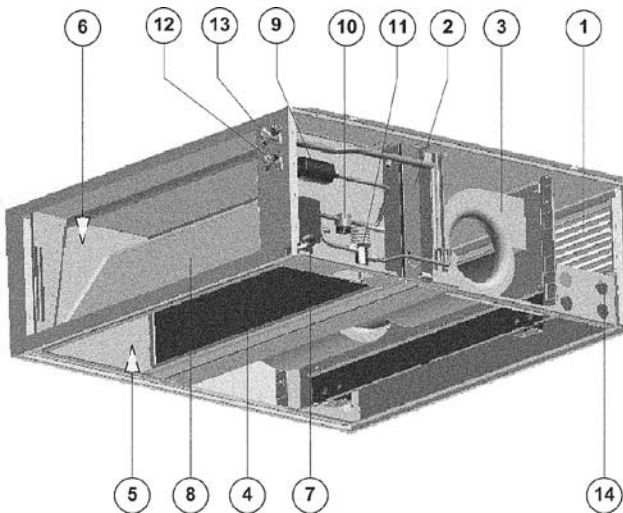

Fig.3 - THi Main Components



Tab.5 - THi Main Components

REF.	DESCRIPTION
1	Air discharge grille
2	Evaporator coil
3	Evaporator fan
4	Air filter
5	Return air section
6	Freecooling air inlet section
7	Damper motor (only with freecooling)
8	Damper (only with freecooling)
9	Filter dryer
10	Sight glass
11	Thermostatic valve
12	Refrigerant inlet connection
13	Refrigerant outlet connection
14	Power supply inlet

ADVANCED (Carel pCO²)

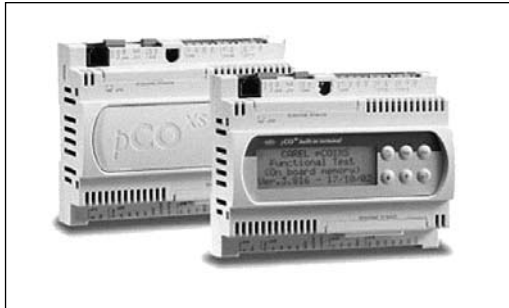

The **THS** units can be supplied with one microprocessor control levels:

- **without local user interface**
- **with built-in display 4x20 LCD**

A remote display is available too, and can be positioned up to 200m far with a simple plug-in connection with phone-type cable.

All microprocessors, **ADVANCED** and **ADVANCED** with built-in display 4x20 LCD, enable to control completely the units, such as:

• **Sensors :**

- room temperature to keep the inner set-point
- outer temperature to pilot the Free-Cooling damper
- delivery temperature to prevent the risks of thermal shocks of the room electronic equipment
- condensing pressure (optional)
- evaporating pressure (optional)

• **Functions :**

- room temperature management
- reading of the relative humidity (optional)
- control of the air outlet min. temperature in the environment
- control of the air de-humidification by reducing the fan speed (with optional sensor and with optional dc fans)
- heating (optional)
- alarm control equipped with clean contacts for the remote connections of visual and sound systems
- stand-by management of two units.

The LAN connection by the **ADVANCED** microprocessor, ensures other functions such as **SMART**, **Free-Cooling**, **modem sharing**, etc.

- clean contacts for every other type of alarm (optional)
- from the microprocessor it is possible to select the automatic restart after a voltage lack
- min. time between two compressor start-ups
- remote interface, up to 200 m, directly connected using a LAN connection (for mP **ADVANCED**)
- possibility of connecting the unit with a supervision system (optional)
- 2 password levels to access the unit configuration
- clock card for recording the even date and time
- hour-counter to enable a scheduled maintenance of the fans, compressors and filters

1- ADVANCED microprocessor

Programmable microprocessor with 16-bit and high performances.

2 - Air differential pressure switch

3 - Double supply

• AC main supply from the mains:

- Compressor/s
- Fan/s of the condensing section
- Heating

• Auxiliary supply 48 VDC:

- Microprocessor
- Evaporating section fan

Note : it is possible to activate the fan speed control to enable the coil energy saving during its operation.

- Damper servomotor

4 - Free - Cooling with damper

Thanks to the unit designing principle, it is possible to carry out the "upgrading on site" on the units not equipped with the Free-Cooling option.

5 - ETV - T “ Electronic Thermostatic Valve Technology”

For applications where the direct Free-Cooling is not possible. This solution enables to reduce the energy consumption up to 50% compared to the standard units when the outdoor temperature is below 20°C.



6 - Humidity sensor

For the enthalpic control in the Free-Cooling situations, combined with the mP ADVANCED control.

7 - Condensation control

8 - Interconnectivity

- Serial port:
 - RS232
 - RS485
- Communication protocol:
 - Carel
 - Modbus®
 - LonWorks®
 - BACnet™
 - TCP-IP
 - GSM modem (complete management through SMS Services).

Free - Cooling Technology

The innovative Free-Cooling system enables to reach outstanding efficiency levels, above all when operating simultaneously with the mechanical cooling: this situation, in many central European climate areas, represents over 50% of the yearly total hours.

The damper is further designed to be integrally extracted, thus enabling a complete maintenance possibility as well as the access to the condensate collection tray.

The THS designing concept enables the upgrading on site of units not equipped with the Free-Cooling option; this is important in such cases where it is necessary to have a unit stock at disposal.

The temperature sensors installed at delivery, intake and fresh air control completely the damper, improving its energy efficiency and avoiding the risk of inlet air at temperatures lower than the limit allowed by the electronic equipment.

In case of combination with DUAL supply, mains + DC UPS, the Free-Cooling can enable to control the climate even in emergency situations and, if the two units are reciprocally connected, it can implement all strategies for avoiding to lose the control of the inner set point of the container (see Fig. 4).

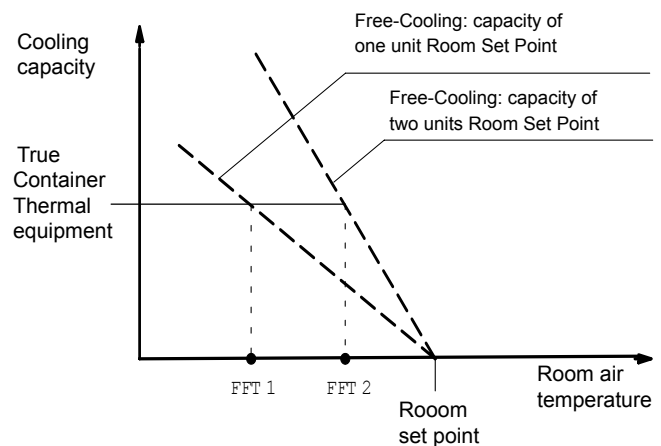

Damper servomotor with spring return

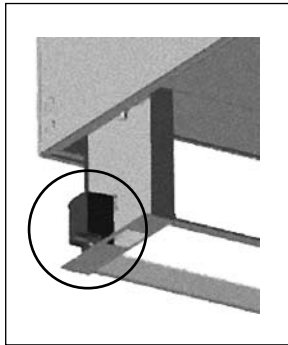

It positions the dampers completely open or completely closed at the customer's choice in case of power lack : with an operation signal connected with a fire alarm, the damper is usually positioned closed, to enable the operation of the automatic switching-off systems. This option must be defined at the order.

Clogged filter sensor

This differential pressure sensor detects the filter clogging and generates an alarm displayed by the microprocessor control.

Heating

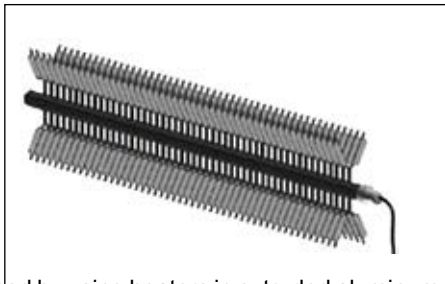

It is performed by using heaters in extruded aluminum, with high thermal exchange surface: this aspect enables to match reduced thermal inertias with reduced surface temperatures, to the advantage of a full use safety. Each heating element is protected by a safety thermostat directly acting on the supply.

Outer paneling

The standard supply includes panels in painted galvanized sheet metal RAL7035. Surface treatments on finned coils

An efficient protection against corrosive agents is guaranteed by the copper-copper version, the cataphoresis protection and the use of hydrophile pre-treated aluminum : the protection grade is reported in the mentioned order.

Refrigerants

According to the norm EEC 2037/00, the THSunits can operate with :

- HFC R407C as standard
- HCFC R22 Export non-EEC in the countries signing the Montreal protocol

The unit is supplied : tested and ready to be started up on the site.

Alarms

It reports high and low priority alarms on clean contacts. In case of ADVANCED microprocessor, it is possible to have a subdivision of the alarm type in the terminal board of the electric panel and, generally, it is possible to arrange Custom solutions according to the different supply standards of the phone companies.

Air distribution grilles

The air distributions grilles are made of extruded aluminum, with single row of adjustable fins and accident-prevention protection net on the delivery. In case of Free-Cooling unit, a further filter is arranged on the air outlet to prevent the unwished entry of small animals and/or insects.

Safety

The **THS** units have been designed, manufactured and tested according to the directives of the European Union :

- **98/37/EC**
(former 89/392/EEC, 91/368/EEC, 93/68/EEC)
- **89/336/EEC**
- **73/23/EEC**

Electric boards

The electric boards comply with EN 60204-1.

Electro - magnetic compatibility

The THS units complies with the following EMC standards:

- **EN 50081-1, Emissions**
("Generic emission standard, Part 1 : residential, commercial and light industrial", January 1992)
- **EN 50082-2, Electro-magnetic compatibility**
("Generic emission standard, Part 2: industrial environment", March 1995)

Conformity

Each **THS** unit is supplied complete with test certificate and conformity certificate according to the Directives of the European Union. The units are "CE" marked.



Tab.6 — THI Performance table

MODEL : THI - INTERNAL UNIT	025	035	045	056	073	090	105	120	145
Refrigerant [Ashrae]	R407C								
Cooling capacity [Total] [I.T. 27°C; R.H. 40% / O.T. 35°C] kW	2.60	3.60	4.50	5.60	7.30	9.00	10.40	12.00	14.50
Power supply [Standard] V / Ph / F	230 / 1 / 50								
Fan/s absorbed power W	185		245			470		690	
Fan/s No	1					2			
Refrigerating circuit No	1								
Evaporator air flow m3/h	950	930	1400			2200		3200	
Indoor coil front surface m2	0.16				0.29			0.37	
Air filter efficiency -	EU 3								
Free Cooling air flow m3/h	810	790	1190			1870		2720	
Free Cooling temperature °C	17.5	13.5	15.8	13.0	15.5	12.7	10.5	14.0	11.2
Width x Height x Depth mm	1040x350x590			1040 x 350 x 990			1140 x 400 x 1090		
Weight kg	64	64	83	83	87	94	94	105	106

Tab.7 — THC Performance table

MODEL : THC - EXTERNAL UNIT	025	035	045	056	073	090	105	120	145
Refrigerant [Ashrae]	R407C								
Power supply [Standard] (**)V / Ph / F	230 / 1 / 50 400 / 3 / 50								
Absorbed power [Total] W	940	1180	1320	1760	2210	2560	3070	3720	4720
Absorbed current [Total] A	3.4	4.6	4.9	7.4	9.6	4.5	5.1	6.2	8.2
FLA A	6.3	8.8	9.5	12.0	15.0	7.0	7.0	10.0	13.0
LRA A	18.3	28.0	34.0	47.0	64.0	40.0	46.0	50.0	66.0
Compressor Type	Rotary		Rotary(*)			Scroll			
No	1								
Refrigeration circuit No	1								
External coil front surface m2	0.25				0.54			0.67	
Condenser air flow m3/h	2250	2050	3450	3350	3350	5100	5100	5580	5450
Condenser fan No	1								
Sound power level dB(A)	68		69		70		73		71
Sound pressure level [at 10m in free field] dB(A)	41		42		43		46		44
Width x Height x Depth mm	600 x 580 x 350			990 x 630 x 360			1120 x 1128 x 578		
Weight kg	77	78	86	88	92	98	106	130	133

EVAPORATING UNIT : MODEL THI 025 - 035

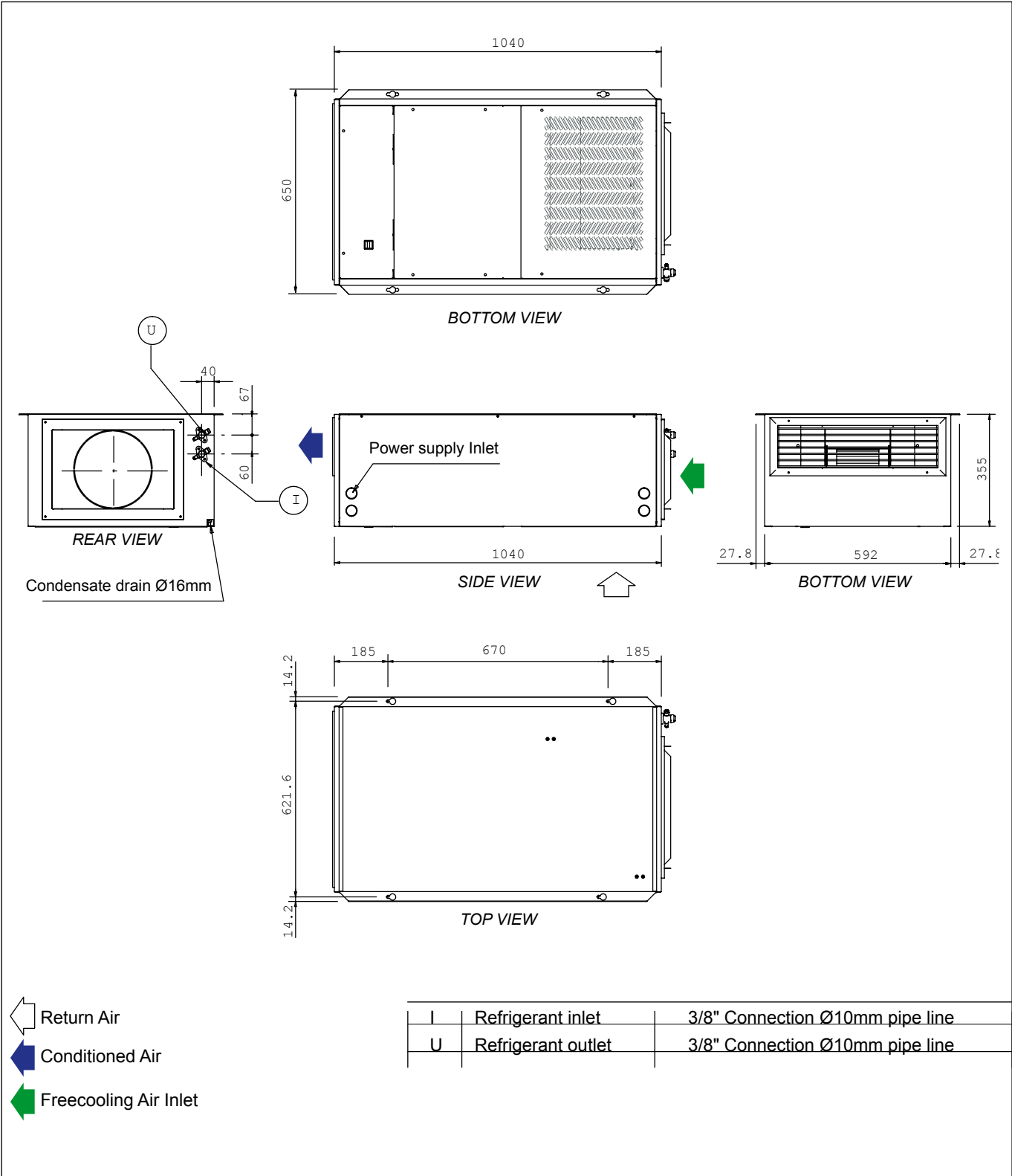

EVAPORATING UNIT : MODEL THI 045 - 056 - 073 - 090 - 105

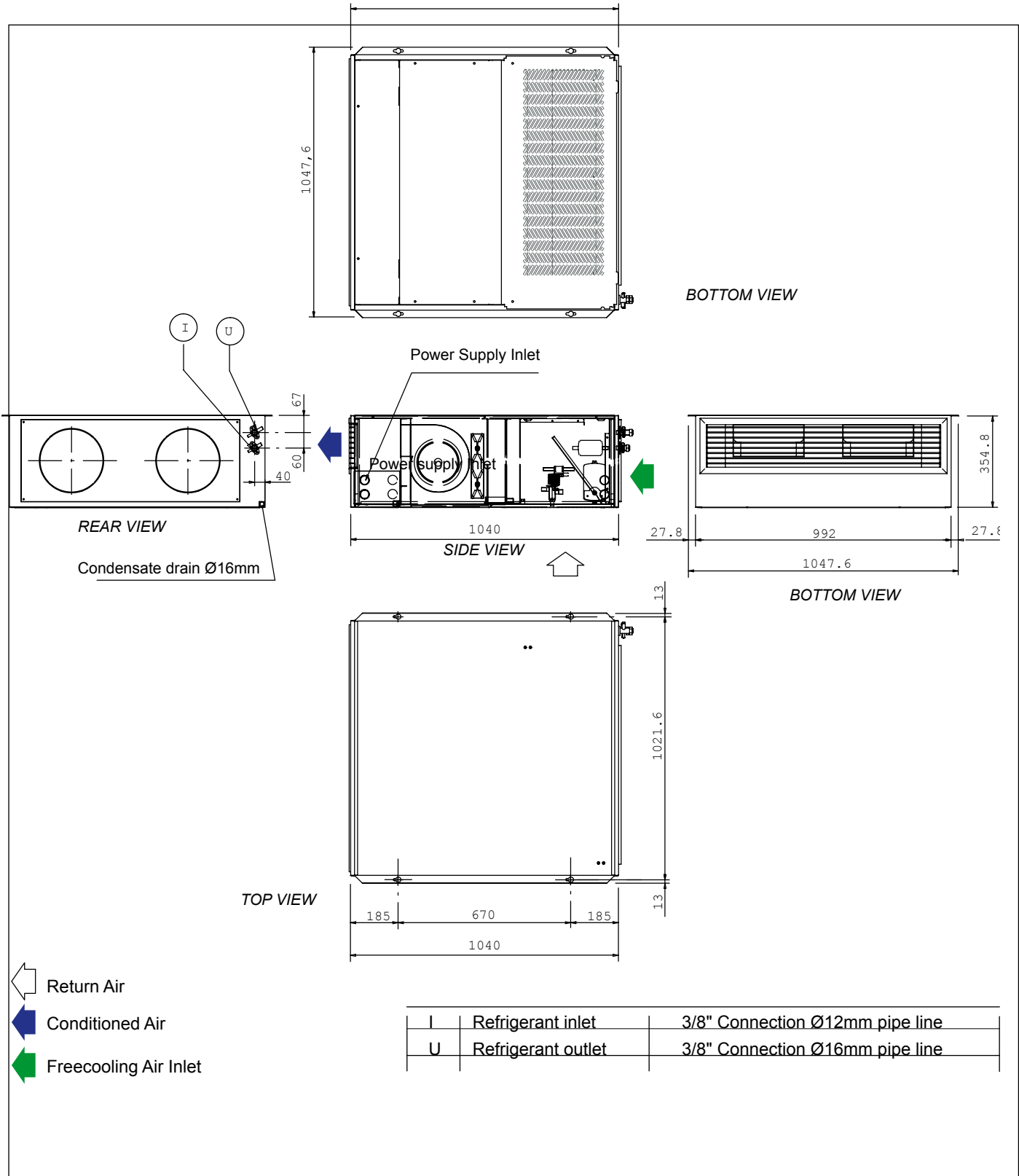

I	Refrigerant inlet	3/8" Connection Ø12mm pipe line
U	Refrigerant outlet	3/8" Connection Ø16mm pipe line

EVAPORATING UNIT : MODEL THI 120 - 145

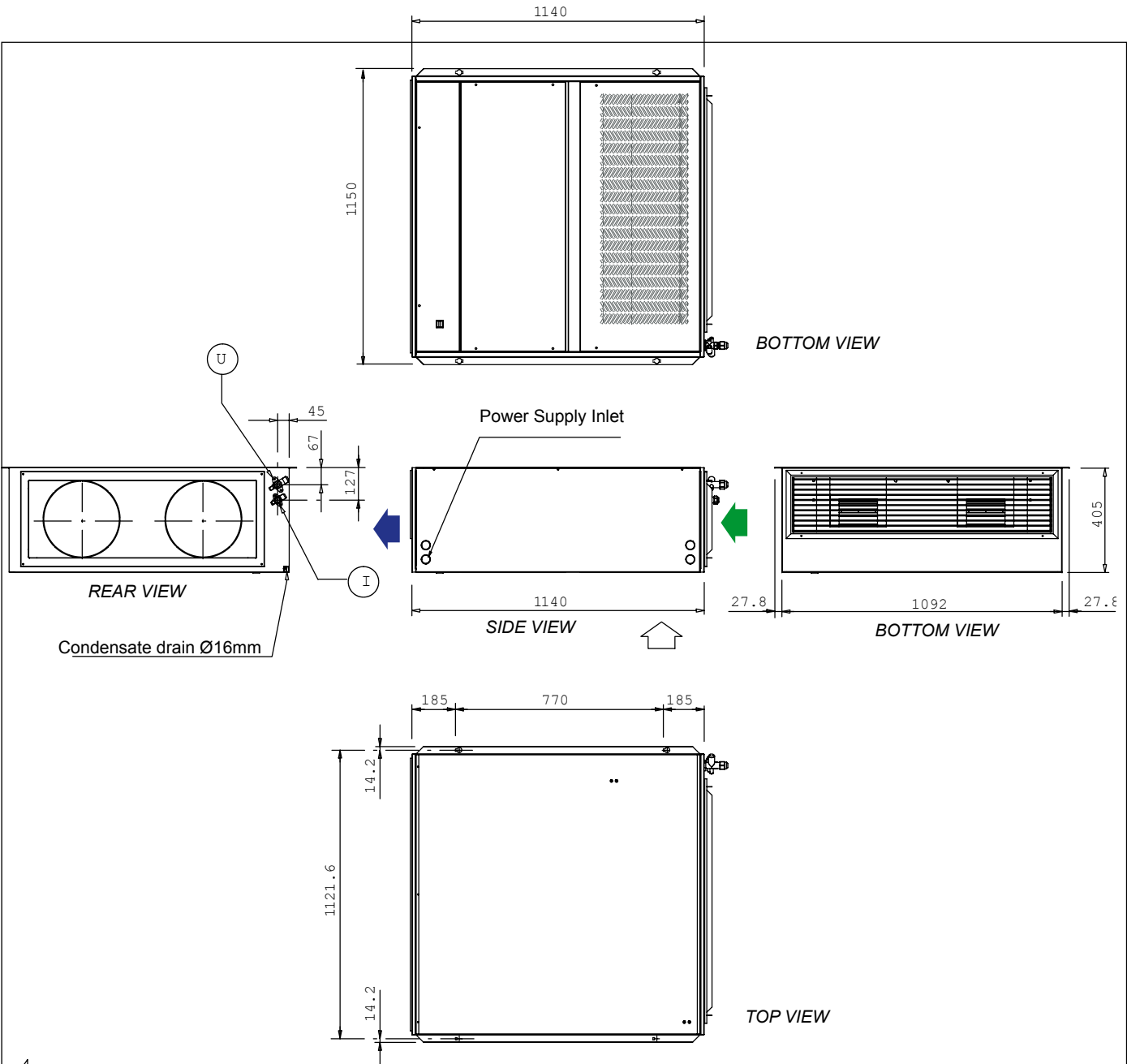

- Return Air
- Conditioned Air
- Freecooling Air Inlet

I	Refrigerant inlet	1/2" Connection Ø10mm pipe line
U	Refrigerant outlet	7/8" Connection Ø10mm pipe line

EVAPORATING UNIT : MODEL THC 25 - 35

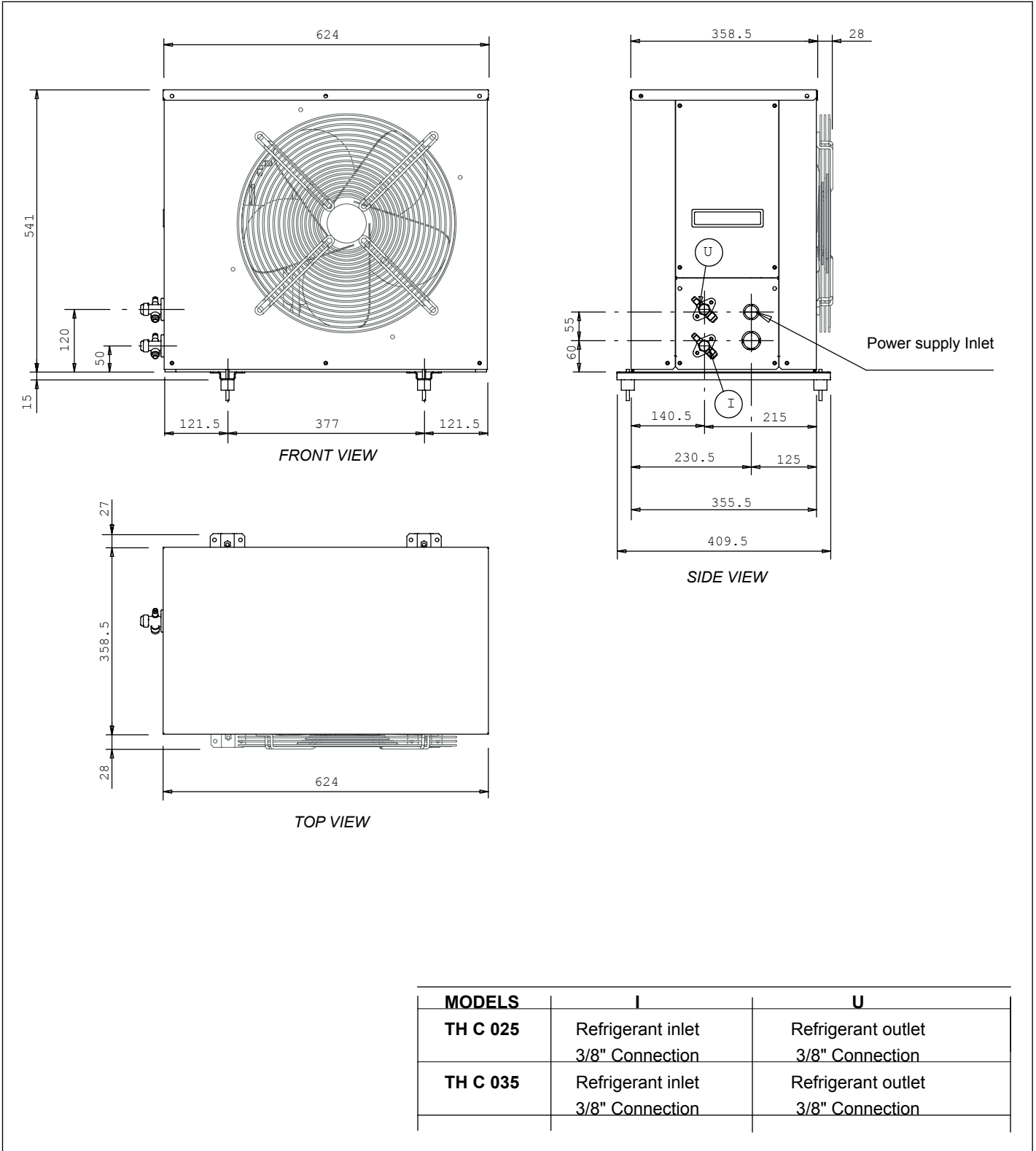

EVAPORATING UNIT : MODEL THC 045 - 056 - 073 - 090 - 105

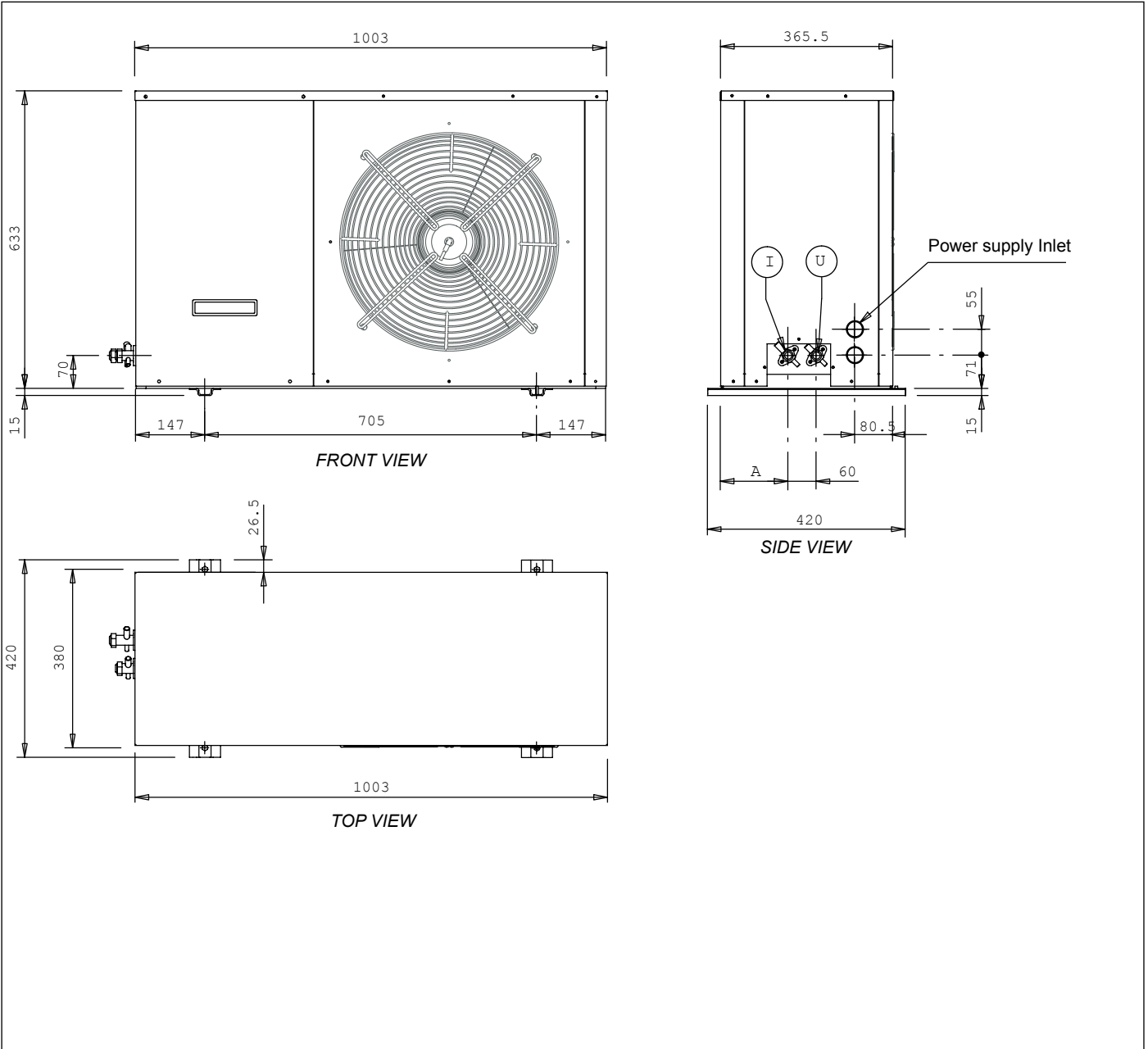

MODELS	A	I	U
THC 045	122	Refrigerant inlet 5/8" Connection	Refrigerant outlet 3/8" Connection
THC 056	122	Refrigerant inlet 5/8" Connection	Refrigerant outlet 3/8" Connection
THC 073	122	Refrigerant inlet 5/8" Connection	Refrigerant outlet 3/8" Connection
THC 090	144	Refrigerant inlet 5/8" Connection	Refrigerant outlet 3/8" Connection
THC 105	144	Refrigerant inlet 5/8" Connection	Refrigerant outlet 3/8" Connection

EVAPORATING UNIT : MODEL THC 120 - 145

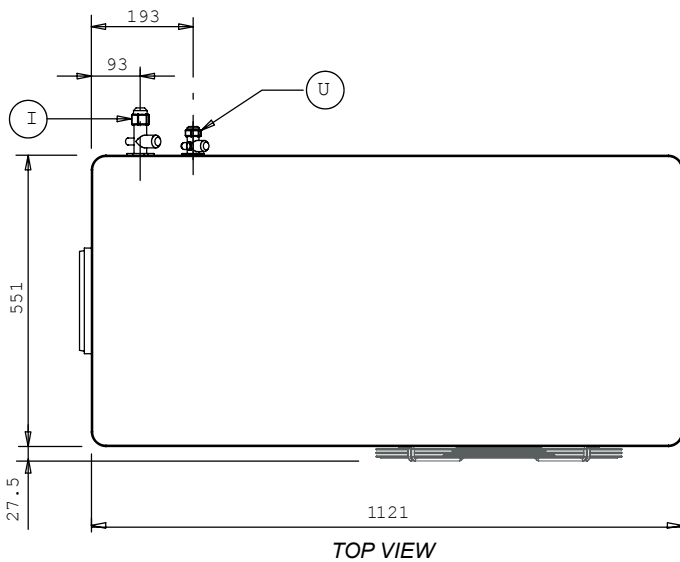
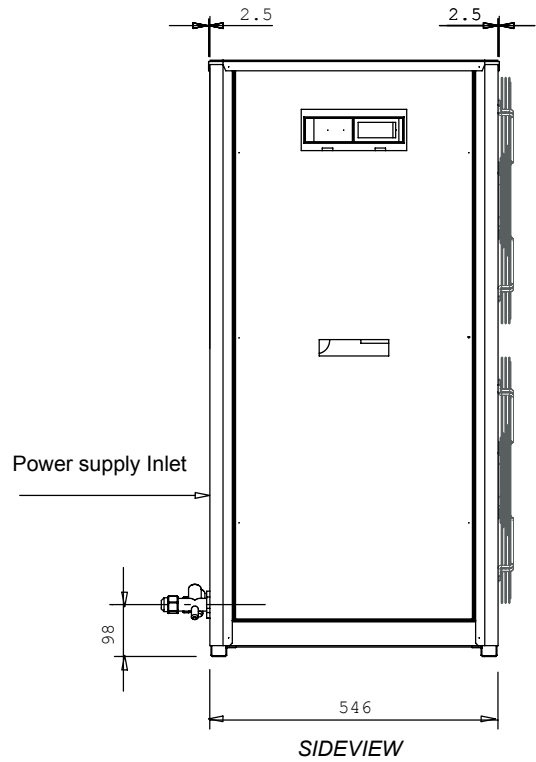
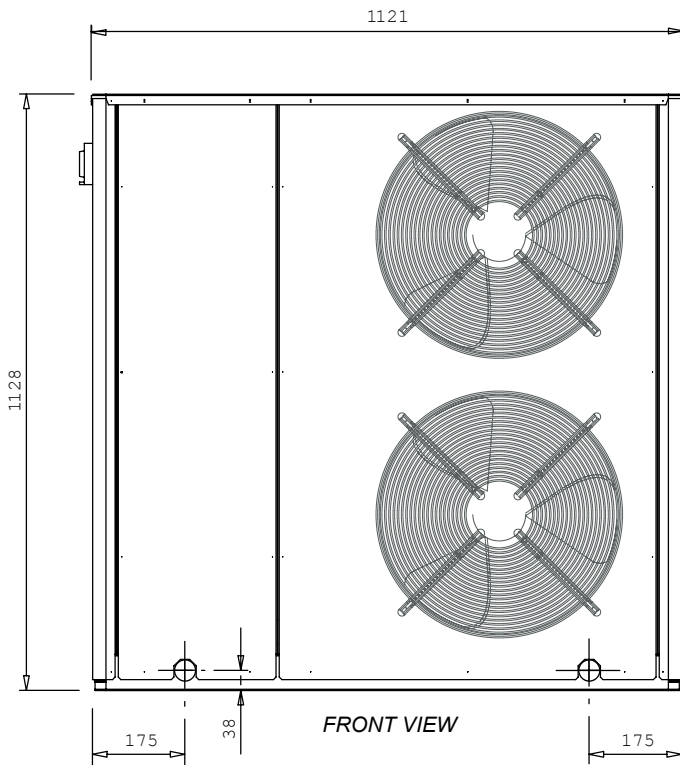

MODELS	I	U
TH C 120	Refrigerant inlet 7/8" Connection	Refrigerant outlet 1/2" Connection
TH C 145	Refrigerant inlet 7/8" Connection	Refrigerant outlet 1/2" Connection

EVAPORATING UNIT : MODEL THS 025 - 035 - 045 - 056 - 073 -090 - 105 - 120 - 145

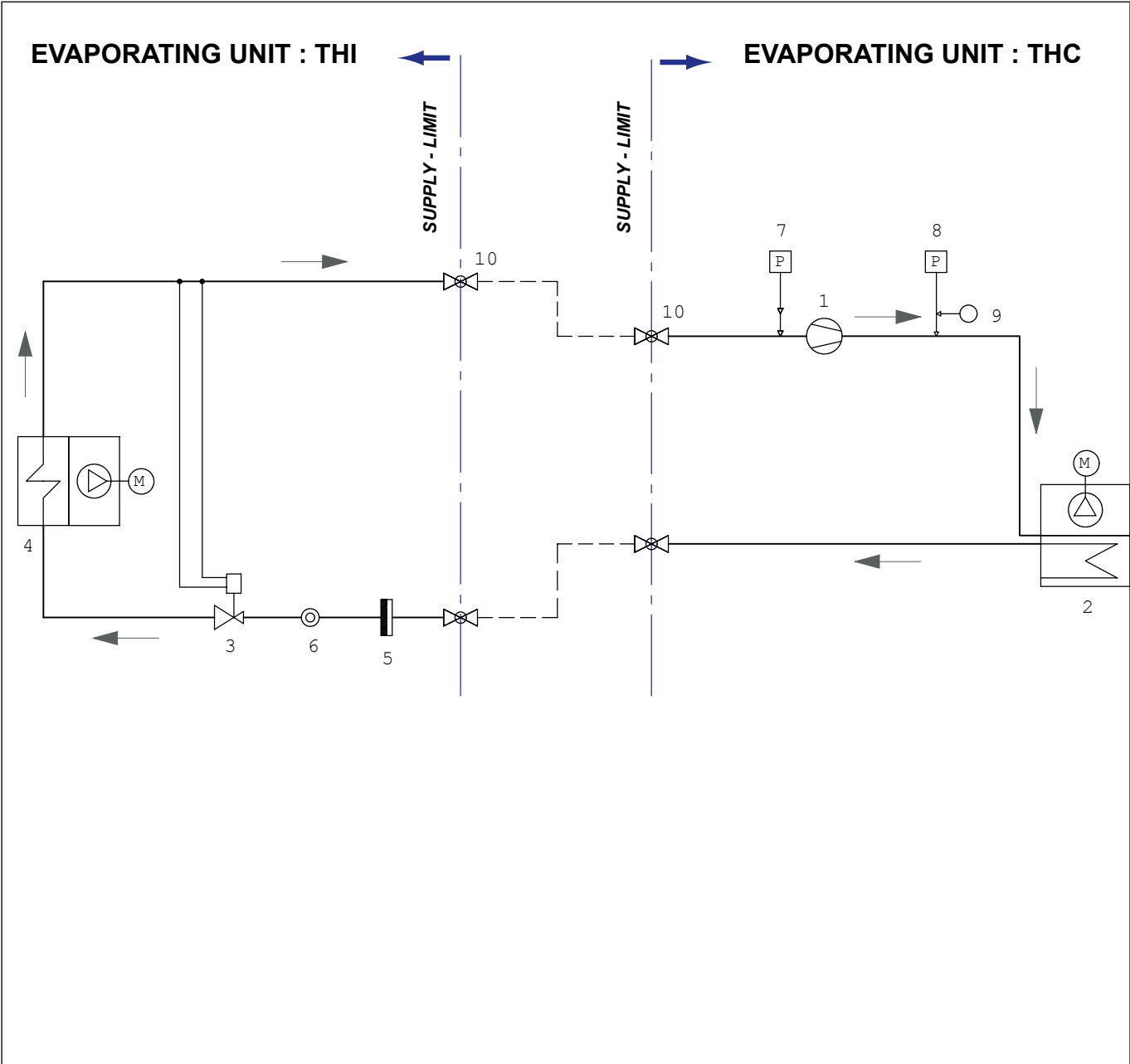

REFERENCE	DESCRIPTION	REFERENCE	DESCRIPTION
1	Compressor	6	Sight glass
2	Condenser	7	Low pressure switch (LP)
3	Thermostatic valve	8	High pressure switch (HP)
4	Evaporator	9	Condensing pressure probe
5	Filter dryer	10	Tap



www.lennox europe.com

BELGIUM, LUXEMBOURG
www.lennoxbelgium.com

CZECH REPUBLIC
www.lennoxczech.com

FRANCE
www.lennoxfrance.com

GERMANY
www.lennoxdeutschland.com

NETHERLANDS
www.lennoxnederland.com

POLAND
www.lennoxpolska.com

PORTUGAL
www.lennoxportugal.com

RUSSIA
www.lennoxrussia.com

SLOVAKIA
www.lennoxdistribution.com

SPAIN
www.lennoxspain.com

UKRAINE
www.lennoxukraine.com

UNITED KINGDOM AND IRELAND
www.lennoxuk.com

OTHER COUNTRIES
www.lennoxdistribution.com

Due to Lennox's ongoing commitment to quality, the Specifications, Ratings and Dimensions are subject to change without notice and without incurring liability.

Improper installation, adjustment, alteration, service or maintenance can cause property damage or personal injury.

Installation and service must be performed by a qualified installer and servicing agency.



@DNOVA-THS-AGU-0907-E