

Application guide @DNOVA - THX

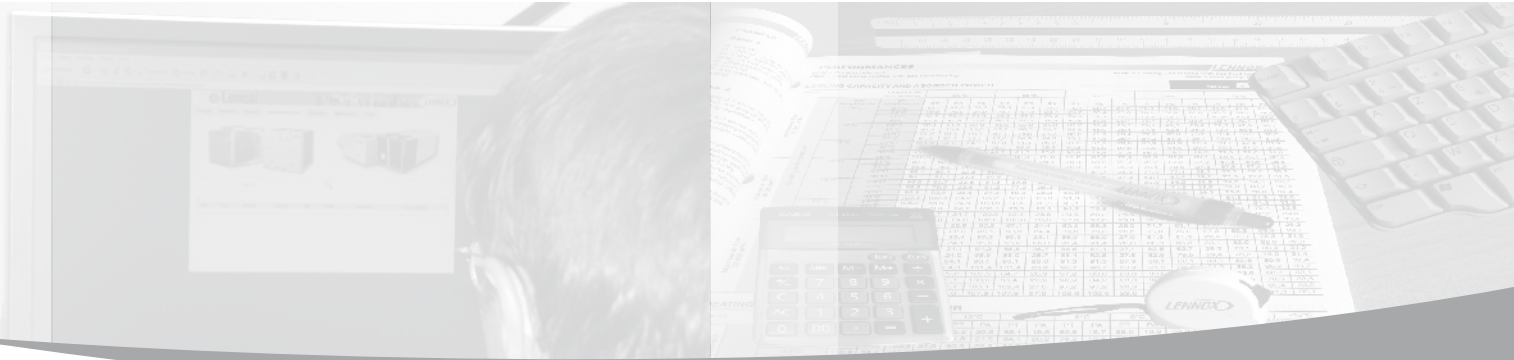

- Providing indoor climate comfort



APPLICATION GUIDE

Ref : @DNOVA-THX-AGU-0907-E

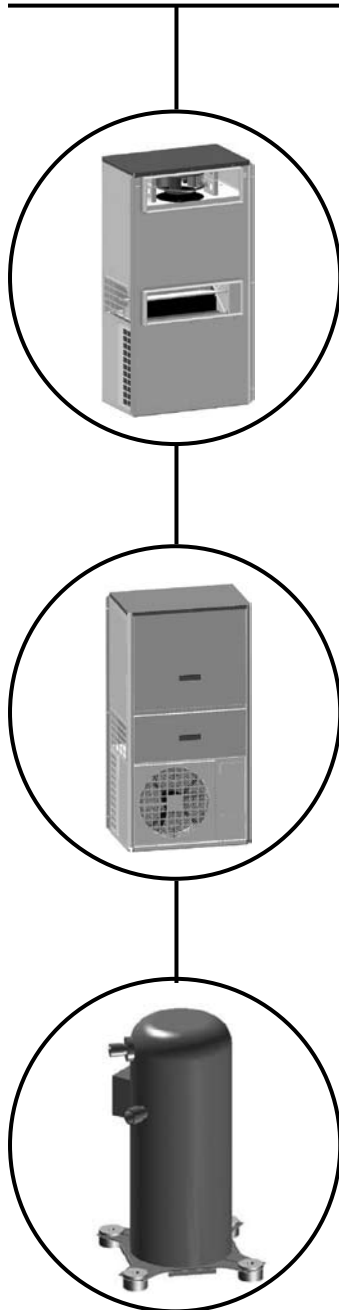

1. THX : DESIGN AND TECHNOLOGY	02
2. FEATURES AND BENEFITS	03
3. CONFIGURATION DIGIT	04
4. MANUFACTURING SPECIFICATIONS	05
5. CONTROL SOFTWARE AND HARDWARE	09
6. LIST OF MAIN OPTIONS	10
7. TESTS AND REFERENCE STANDARDS	12
8. TECHNICAL DATA	13
9. DIMENSIONAL DRAWINGS	14

Our products comply with the European standards.



The manufacturing @DNOVA units answers to ISO 9001 control quality system. A copy of the certificate can be get on request.



Lennox have been providing environmental solutions since 1895, our range of @DNOVA continues to mee the standards that have made LENNOX a household name. Flexible design solutions to meet YOUR needs and uncompromising attention to detail. Engineered to last, simple to maintain and Quality that comes as standard. Information on local contacts at www.lennox europe.com.

All the technical and technological information contained in this manual, including any drawing and technical descriptions provided by us, remain the property of Lennox and must not be utilised (except in the operation of this product), reproduced, issued to or made available to third parties without the prior written agreement of Lennox.

Due to LENNOX on going commitment to quality, specifications subject to change without notice and without incurring liability

THX = Design & Technology

THX unit

The units of the series **THX** .Lennox Telecom units Wall mounted. are to be used for the conditioning of small and medium sized telecommunications transceiver stations or switches.

Wall mounting

The machines are designed for an outdoor wall mounting with Plug & Play logic, to reduce the installation times and the need of specific professional skills in the installation step.

Direct expansion

The **THX** units are single-block conditioners with direct expansion and air condensation. The innovative system of air circulation embodies a significant improvement of the performances in different thermal load conditions.

Reduced noise level

The use of innovative axial fans with 6-pole backward curved blades, together with a Scroll-type compressor and a cabinet design eliminating every source of inner sound reflection and vibrations,makes this equipment suitable especially for city areas.

Minimized pressure drop

The whole recirculating and Free-Cooling section has been designed to limit the pressure drop (air side) and to maximize the unit performance; for this reason, the **THX** units are featured by the exclusive equipment with backward curved blade centrifugal fans (Plug fans), the wide surfaces of the evaporating coils and of the intake grilles, in line with the supply standard of the main phone companies.

Structure

The unit supporting structure is made of thick galvanized sheet, while the outer part is in aluminum alloy 5005 (standard) or in painted galvanized sheet metal RAL 9002 (optional). It is featured by rounded shape edges, according to innovative style trends and the accident prevention. All structure details are entirely produced in-house with automatic processes integrating the CAD-3D designing (solid modeller) with the production process (CAM) = CAD-CAM.

Panelling

All outer panels are fastened using anti-vandal screws TORX®, while the front ones are equipped with handles for an easy removal for inspections. The unit maintenance can be fully made from the front, including the innovative extractable damper section. This enables a unique flexibility, with unit ."On Site Upgrading".and the possibility to access and clean the condensate collecting tray.

Power supplies

All units are available with different supply voltages, with the option of double power supply. In this case it is possible to have a 48 v dc or 24 V dc solution for the air-conditioning control, even in case of power failure.

European directives

The THX units are designed and manufactured according to the European directives currently in force, and are consequently marked CE.



Features and fortes

Design vs. Technology?

The THX units introduce a new plant model featured by a pleasant design matched with a rational arrangement of the components and an excellent assembly compactness. The single-compressor unit reduced dimensions enable to install two units on a 2.20-mwall, as for the shelters including the mini stations for wireless telephony. The special Lennox concept of SFT Side Free-Cooling Technology. enables to reach a real operation under partial load conditions with possible simultaneous mechanical cooling, even when the two

units operate together. The two-compressor series .2. matches the safety of the two machines with the inexpensiveness of the single unit, with a power range covering about 80% of the installed. All units are factory tested by using automatic systems based on objective .in-out. criteria and are ready to be installed and started by simple wiring on site.

Start-Up

The holes arranged on the rear flange enable the machine/s wall-mounting; the condensate discharge is to be arranged and the power supply is to be connected. In case of units with three-phase main supply, check the phase correct sequence (the indicator on the phase sequence relay in the electric board switches on); in case of wrong sequence, themP control records an alarm and does not enable the compressor start. The starting procedure is operated by pressing the key .ON. on the control keyboard.

Handling

The THX units can be handled by fitting belts under the base and paying attention to make them pass through the supplied anti-tilting eyebolts, fastened in the upper side part.

Noise levels

The THX units include the exclusive use of ventilation solutions, featured by a low emitted noise level making these conditioners compatible with city installations. The support structure, the panels and the fastening systems are designed to reduce vibrations and their transmission as low frequency sound emissions as much as possible.

Energy efficiency

The highest possible energy efficiency has been the main target in the whole thermo-dynamic and aeraulic designing. The refrigerating circuit is featured by the use of .rolling piston. or .Scroll. compressors with top reliability and (optional) possibility of replacing the traditional lamination component with an electronically-controlled electric valve: this brings a reduced energy consumption by 50% when the outer temperature lowers below 20°C and, above all, when the direct free-cooling is not possible. The aeraulic circuit implies the use of centrifugal fans

with backward curved blades, featured by a very high reaction degree, it is thus possible to remove the scroll and the relevant energy losses in the dynamic-statical conversion; all used fans can be equipped with .brushless. motor with permanent magnets and relevant switching electronics, that can be directly powered by an emergency mains at 48 V dc or 24 V dc. In this case, the dc motor efficiency matches with the fan efficiency, thus reaching outstanding energy results (over 45%). The SFT® concept developed by Lennox achieves, as well as exceptional aeraulic performance, a true exploitation even together with the mechanical cycle: this contributes remarkably to reduce energy costs in the range of outer temperatures between the inner set point and TFT (Total Free-Cooling temperature).

Emergency situations

All units can be equipped with dual supply, main supply and "dc" supply.

- *Main supply:*
 - Compressor
 - Heating
 - Condensing section fan
- *24 V dc or 48 V dc supply:*
 - evaporating section fan
 - Microprocessor
 - Damper servomotor

In case of mains failure, a voltage presence relay signals this to the "mP" control that, together with the ventilation and Free-Cooling section, continues to be powered by back-up batteries. This ensures the air-conditioning control even with possible inner temperature variations from the set-point values. Manufacturing features All electric, aeraulic and refrigerating components are assembled inside the machine cabinet and cannot be accessed from outside, without removing the panels. All removable fastenings by .AVA Screws. need special tools (optional) for their removal. The machine has amin. protection degree IP 44 and the protection grilles of the rotary parts comply with the accident prevention section of the norms EN 60335; as option, a further protecting grille for the condensing section fan front is available.

Upgrading

The THX series is developed on two dimensional .frames. only, in the single-compressor version, and on a single .frame. in the two-compressor version. This enables the upgrading of the basic radio stations due to the implementation of new transmission standards, and therefore to the increase dinner thermal load.

THX0 045 1 H123456789

Family: _____
Lennox Telecom Wall mounted

Refrigerant capacity
"KW x 10"

Configuration DIGITS

1 - Supply + (Auxiliary)	0	230 V / 1 Ph / 50 Hz
	1	230 V / 1 Ph / 50 Hz + (24 V dc)
	2	230 V / 1 Ph / 50 Hz + (48 V dc)
	3	230 V / 1 Ph / 50 Hz + (230 V / 1~ / 50 Hz)
	4	400 V / 3 Ph + N / 50 Hz
	5	400 V / 3 Ph + N / 50 Hz + (24 V dc)
	6	400 V / 3 Ph + N / 50 Hz + (48 V dc)
	7	400 V / 3 Ph + N / 50 Hz + (230 V / 1~ / 50 Hz)
2 - Check	A	BASIC (with local user terminal) - [Carel iAC]
	B	ADVANCED (without terminal- local) - [Carel pCO2]
	C	ADVANCED (with built-in terminal) [Carel pCO2]
3 - Refrigerating cycle options	0	R407C
	1	R407C + electronic thermal expansion valve
	2	R22
	3	R22 + electronic thermal expansion valve
	4	R134a
	5	R134a + electronic thermal expansion valve
6	Other	
4 - Cabinet options	D	Aluminum Peraluman Alloy 5005
	E	Painted galvanized sheet
5 - Electric re-heating	0	Heaters - NO
	1	Heaters - YES
6 - Free-Cooling	F	Without Free-Cooling
	G	Modulating Free-Cooling 0-10 V
	H	Free-Cooling with spring return
7 - Air filtration	0	G2 Filter (Std.)
	1	G3 Filter
	2	G4 Filter
	7	G2 Filter + Clogged filter sensor
	8	G3 Filter + Clogged filter sensor
	9	G4 Filter + Clogged filter sensor
	K	Other
8 - Condensation control	L	Without condensation control
	M	On / Off
	N	Modulating with pressure transducer
	P	Modulating with temperature probe
	Q	Flooding-type
9 - Serial communication options	1	Serial card RS232 Modem
	2	Serial card RS485
	5	Free
		"-1-" only for ADVANCED control

Manufacturing specifications

Structure

The THX series units are dedicated to the outdoor use with temperatures ranging between -20°C (under condensation control) and +45°C. The entire inner structure is made up of hot electro-galvanized sheet with high thickness, and the outer paneling is in smooth 5005 aluminum alloy or, upon request, in galvanized sheet painted with epoxy-polyester powders RAL xxxx, oven-cured at 180°C. If painted, the colour of the units depends on the customer's specifications for re-order batches of more than 20 pieces. The innovative global design of the machine enables a complete front accessibility whereas the outstanding possibility of extracting/fitting the damper from the front offers the double chance of upgrading on site of the machines originally without the Free-Cooling option, and it offers the accessibility to the evaporating coil and to the condensate collection tray, too.

Refrigerating circuit

The refrigerating circuit is entirely in house manufactured, using welders certified according to the Directive PED 97/23 on pressurized containers, and all relevant components are certified according to the same directive. The exclusive rotary or scroll-type used compressors are available in the version for fluids type HFC (R407C; R134a); for the non-EEC countries signing the Montreal Protocol, in the version with HCFC R22. The machine standard equipment includes a thermostatic lamination valve and a vacuum start device: this device is enclosed in the Scroll compressor or is outside in the versions with single-phase rotary compressor/s. The circuit is completed with anti-acid dryer filter with molecular sieve, a flow indicator and pressure intakes for the maintenance and/or inspection operations.



Evaporating section fan

The THX units are fitted with centrifugal-type fans, with (tilted) backward curved blades and single intake. These fans are featured by diverging blade ducts and by a high outer diameter/inner diameter ratio, enabling to achieve an outstanding aerodynamic efficiency; further, a high output speed and therefore a launch over seven meters can be reached through their position towards the delivery grille. All machines can be equipped with fans powered by brushless motors with permanent magnets, dc supplied at 48 V or 24 V, and in this case, combined with the ADVANCED microprocessor. Therefore, it is possible to pilot directly the rotating speed suiting it to the different operating conditions, such as: de-humidification, energy saving, etc.



Finned pack evaporator

With its dimensions 25x21.65 and a 3/8" pipe it is composed of 0.10-mm thick aluminum fins and copper pipes expanded on the same for a complete contact. The design criteria privileges the front section with the advantage of reduced losses on the air side, while the exchange surface is sized so as to avoid de-humidification at the project rated conditions. The condensate collection tray can be accessed from the unit front for cleaning, and can be in galvanized sheet or, as option, in austenitic stainless steel AISI 304L.

Recirculation air filtration

The filter is located upstream the evaporating coil and can be easily extracted by removing the front panel dedicated to the filter/damper section. Thanks to its position, it filters both the recirculation and the fresh air in case of Free-Cooling: in the latter case, on the fresh air ejection section, a metal filter prevents the nesting inside the container of small animals or insects. The washable synthetic-type fiber filter, with efficiency EU2, is installed in a galvanized sheet frame for an easy maintenance.

Condensing section fan

The axial-type used fans, with wing-shaped blades, are featured by a high covering degree. All used 6-pole motors limit the sound emissions, and are outer rotor type to improve the energy efficiency and reduce the magnetic noise when they are adjusted with phase disconnecting devices (optional).

Condenser with finned pack

With dimensions 25x21.65 and a 3/8" pipe it is composed of 0.10-mm thick aluminum fins and copper pipes expanded on the same for a complete contact. The design criteria privileges the front section with the advantage of reduced losses on the air side, so that it is possible to use 6-pole fans with minimized emitted sound power. The condensing coil can be equipped with a metal filter that can be easily removed from one of the machine sides: this double access enables the maintenance even in case of double installation on the container wall.

Electric board

It is located in a separate cabinet hidden on the back side by the recirculation air before it is cooled by the evaporating coil: this aspect is extremely important for both the component cooling and, at the same time, for preventing the condensation on the bottom side of the board. All on-board systems comply with the EEC Directive "Low tension 73/23" and with the related norms. The access to the electric board is possible with operating unit as it is completely separated from the air flow; the protection degree with open panel is IP20.



Packing

The THX units are packed on wooden pallet with anti-shock cardboard angles and upper protection in cardboard/polystyrene. In the end, the whole packing is wrapped with protection transparent polythene film.

Interconnectivity

All units can be connected with remote supervision systems by the use of .Gateway.. When using the .mP. control of the .ADVANCED. type, there is the possibility of piloting directly a GSM modem able to send and receive SMS messages.

Application field

The machines have been designed to operate with outdoor temperatures "oT" up to +45°C and indoor temperatures "iT" ranging between 18°C - R.H. 40% and 35°C - R.H. 50%. For the applications with low outdoor temperature, the condensation control is required:

- Absent for oT > 20°C
- Modulating for -20°C < oT < 20°C
- Flooding -35°C < oT < -20°C

Up to max. 6 units can be connected for the stand-by . rotation control, with mP BASIC, in LAN (Local Area Networking), while up to max. 15 units can be connected with ADVANCED type mP, sharing the operating parameters and enabling the stand-by rotation and re-start of the installed machines. Indoor temperature from 21_C (from R.H. 30% to R.H. 80%) to 32_C (R.H. 40%) with operating compressor. Refer to the performance table for each model (Tab.4, Page13). The interconnection possibilities, according to control type, are summarized in the two tables below (Tab.1 and Tab.2).

Tab.1 - mP ADVANCED

PROTOCOL	SERIAL CARD	GATEWAY	NOTES
Proprietary Carel	RS485	Not necessary	RS485 network connection
		RS485 / RS232 converter (PC485KIT)	Connection with the supervision PC
Modbus®	RS485	Not necessary	RS485 network connection
BACnet™	RS485	Gateway BACnett™	RS485 network connection
LonWorks®	LON RS485	Not necessary	For the dedicated programming, contact LENNOX
Trend	Trend serial	Not necessary	For the dedicated programming, contact LENNOX
Tcp / Ip	RS485	Gateway TCP / IP	Ethernet network connection
GSM	RS232	GSM modem	For the dedicated programming, contact LENNOX
	RS485 control local network	PlantWatch + GSM modem	PlantWatch operates as concentrator

Tab.2 - mP BASIC

PROTOCOL	SERIAL CARD	GATEWAY	NOTES
Proprietary Carel		Not necessary	RS485 network connection
	RS485	RS485 / RS232 converter (PC485KIT)	Connection with the supervision PC
Modbus®	RS485	Gateway Modbus®	RS485 network connection
BACnett™	RS485	Gateway BACnett™	RS485 network connection
LonWorks®	RS485	Gateway BACnett™	RS485 network connection
Trend	RS485	Gateway BACnett™	RS485 network connection
Tcp / Ip	RS485	Gateway TCP / IP	Ethernet network connection
GSM	RS485 control local network	PlantWatch + GSM modem	PlantWatch operates as concentrator

Fig.1 - Machine Main Units

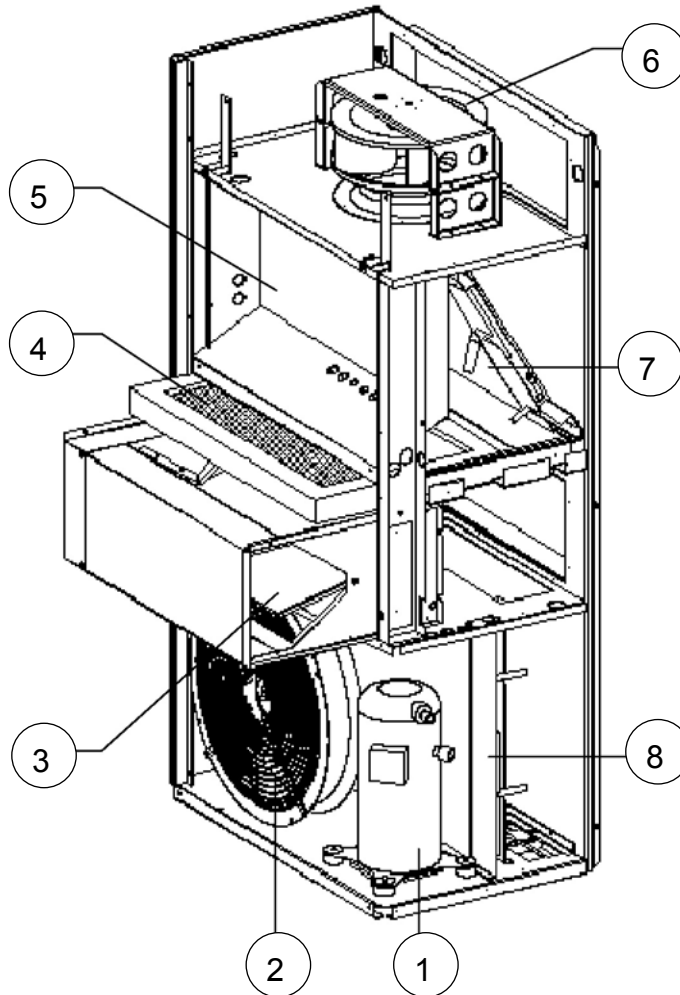

Tab.3 - Machine Main Units

RE.	DESCRIPTION
1	Compressor
2	Condensing section fan
3	Free-Cooling damper
4	Air filter
5	Electric board
6	Evaporating section fan
7	Evaporator
8	Condenser

Machine functional schemes

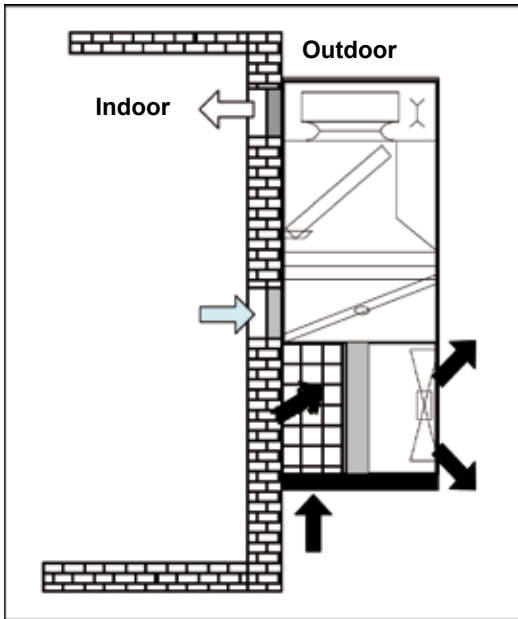

Fig.2 - MECHANICAL COOLING

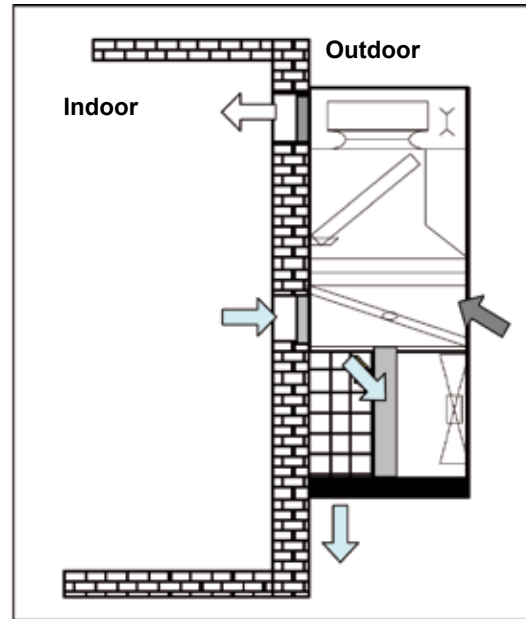

Fig.3 - FREE COOLING

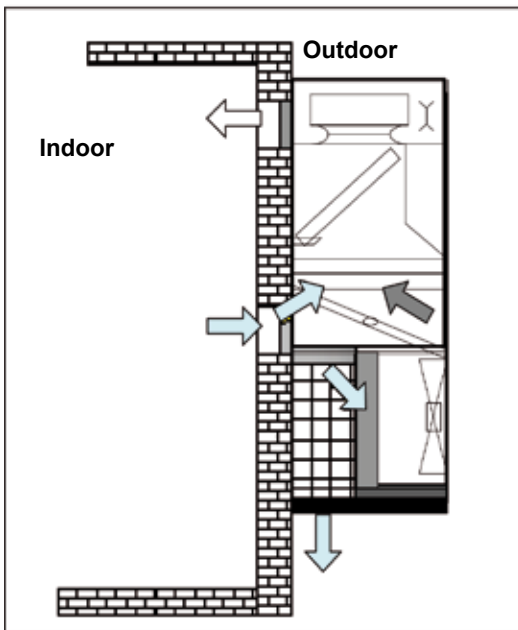

Fig.4 - MODULATING FREE COOLING

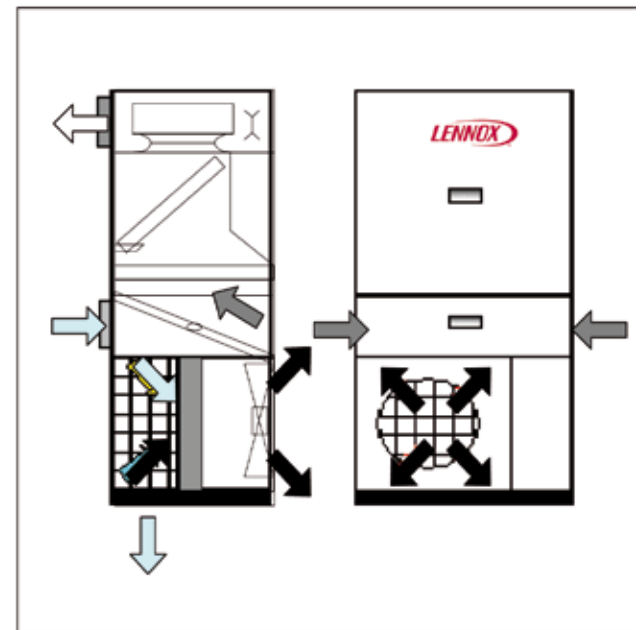
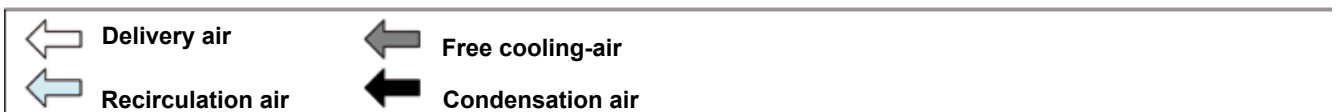

Fig.5 - AIR FLOW IN COMBINED OPERATION



Control software and hardware

BASIC [Carel iAC] + ADVANCED [Carel pCO²]

The THX units can be supplied with two microprocessor control levels :

- **BASIC** with user interface 4x20 LCD
- **ADVANCED** : optional configuration: with built-in display 4x20 LCD



For the ADVANCED controls, a remote display is available, too, and can be positioned up to 200 m far with a simple plug-in connection with phone-type cable.

All microprocessors, BASIC, ADVANCED and ADVANCED with built-in display 4x20 LCD, enable to control completely the units, such as :

• Sensors

- room temperature to keep the inner set-point
- outer temperature to pilot the Free-Cooling damper
- delivery temperature to prevent the risks of thermal shocks of the room electronic equipment
- condensing pressure (optional)
- evaporating pressure (optional)

• Functions

- room temperature management
- reading of the relative humidity (optional)
- control of the air outlet min. temperature in the environment
- control of the air de-humidification by reducing the fan speed (with optional sensor and with optional dc fans)

- heating (optional)
- alarm control equipped with clean contacts for the remote connections of visual and sound systems
- stand-by management of two units. The LAN connection by the ADVANCED microprocessor, ensures other functions such as SMART, Free-Cooling, modem sharing, etc.
- clean contacts for every other type of alarm (optional)
- from the microprocessor it is possible to select the automatic restart after a voltage lack
- min. time between two compressor start-ups
- remote interface, up to 200 m, directly connected using a LAN connection (for mP ADVANCED)
- possibility of connecting the unit with a supervision system (optional)
- 2 password levels to access the unit configuration
- clock card for recording the even date and time
- hour-counter to enable a scheduled maintenance of the fans, compressors and filters
- automatic switching between two compressors for each unit with double refrigerating circuit. The algorithm can be selected to achieve the .one in operation . one in stand by. strategy or to achieve a balanced operating time between two circuits. The second circuit, too, is started when exceeding the preset set-point temperature, independently from the selected control strategy.

Note : the ADVANCED control is available for all units with double circuit, only.

mP ADVANCED [Carel pCO²] technical data

- Flash memory: 1 MByte expandable to 16 MByte
- RAM memory: 256 kByte expandable to 1 MByte
- Parameter memory: ... 2 kByte
- Analog inputs: B4 - B5 = two inputs for NTC probes (-50 ÷ 100°C), PT1000 (-100 ÷ 200°C) / clean inputs
B1 - B2 - B3 = three inputs for NTC probes (-50°C ÷ 100°C); voltage 0 ÷ 1 V dc / 0 ÷ 10 V dc
current 0 ÷ 20 mA / 4 ÷ 20 mA
- Analog outputs: Y1 - Y4 = four opto-insulated outputs 0 ÷ 10 V dc, max. load 10 mA (1 k Ω)
- Digital inputs: ID1 - ID8 = eight opto-insulated inputs 24 V ac 50/60 Hz / 24 V dc
- Digital outputs: No.1 ÷ No. 8 = electro-mechanical relays

mP BASIC [Carel iAC] technical data

- Analog inputs: B1 - B2 - B4 = three inputs for NTC temperature probes (10 k Ω , a 25°C)
B3 = one input for humidity/pressure probe (0 ÷ 1 V dc / 4 ÷ 20 mA) + V = probe supply output (14 V dc, 30 mA max.)
- Analog outputs: Y1 = output 0 ÷ 10 V dc, not opto-insulated, referred to the supply potential G0, max. load 10 mA (1 k Ω .)
Y2 = phase disconnection output
- Digital inputs: ID1 - ID10 = ten non-optoinsulated inputs referred to the supply potential G0, supplied with 24 V ac, current absorbed by each input 6.5 mA at 24 V ac
- Digital outputs: OUT1 - 5 = 5 SSR, 24 V ac, 1 A, with min. current 20 mA
OUT6 - C6 = 1 relay, 220 V ac
OUT7 - C7 = 1 relay, 220 V ac

1 - ADVANCED microprocessor

Programmable microprocessor with 16bit and high performances.

2 - Air differential pressure switch

3 - Double supply

- AC main supply from the mains:
 - compressor/s
 - fan/s of the condensing section
 - heating
- Auxiliary supply 48 V dc (24 V dc, upon request):
 - microprocessor
 - evaporating section fan
 - damper servomotor

Note : it is possible to activate the fan speed control to enable the coil energy saving during its operation.

SFT® "Side Free-Cooling Technology"

The innovative Free-Cooling system enables to reach outstanding efficiency levels, above all when operating simultaneously with the mechanical cooling: this situation, in many central European climate areas, represents over 50% of the yearly total hours.

4 - Refrigerant R134a

For extreme outdoor conditions up to +55°C.

5 - Free-Cooling with damper

Thanks to the unit designing principle, it is possible to carry out the upgrading on site. on the units not equipped with the Free-Cooling option

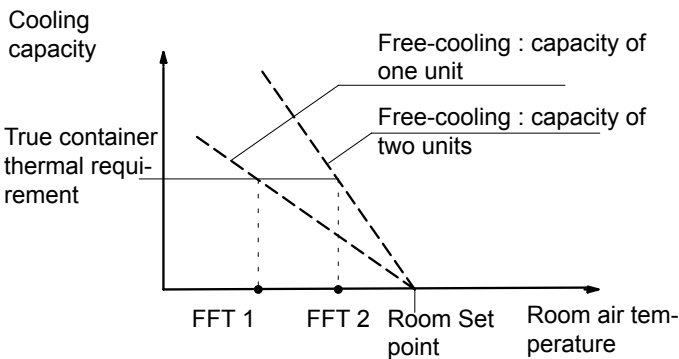

Fig.6 - SFT® operating diagram

6 - ETV--T "Electronic Thermostatic Valve Technology"

For applications where the direct Free-Cooling is not possible. This solution enables to reduce the energy consumption up to 50% compared to the standard units when the outdoor temperature is below 20°C. The damper is further designed to be integrally extracted, thus enabling a complete maintenance possibility as well as the access to the condensate collection tray.



7 - Humidity sensor

For the enthalpic control in the Free-Cooling situations (combined with the mP ADVANCED control).

8 - Condensation control

9 - Interconnectivity

- Serial port:
 - RS232
 - RS485
- Communication protocol:
 - Carel
 - Modbus®
 - LonWorks®
 - BACnet™
 - TCP-IP
 - GSM modem (complete management through SMS Services).

The THX designing concept enables the upgrading on site of units not equipped with the Free-Cooling option; this is important in such cases where it is necessary to have a unit stock at disposal.

The temperature sensors installed at delivery, intake and fresh air control completely the damper, improving its energy efficiency and avoiding the risk of inlet air at temperatures lower than the limit allowed by the electronic equipment. In case of combination with DUAL supply, mains + dc UPS, the Free-Cooling can enable to control the climate even in emergency situations and, if the two units are reciprocally connected, it can implement all strategies for avoiding to lose the control of the inner set point of the container (see Fig. 6).

Damper servomotor with spring return

It positions the dampers completely open or completely closed at the customer's choice in case of power lack: with an operation signal connected with a fire alarm, the damper is usually positioned closed, to enable the operation of the automatic switching-off systems. This option must be defined at the order.

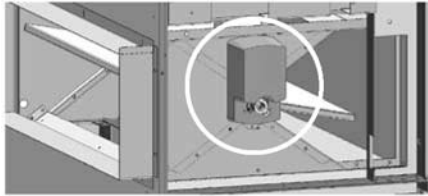

Clogged filter sensor

This differential pressure sensor detects the filter clogging and generates an alarm displayed by the microprocessor control.

Heating

It is performed by using heaters in extruded aluminum, with high thermal exchange surface: this aspect enables to match reduced thermal inertias with reduced surface temperatures, to the advantage of a full use safety. Each heating element is protected by a safety thermostat directly acting on the supply.

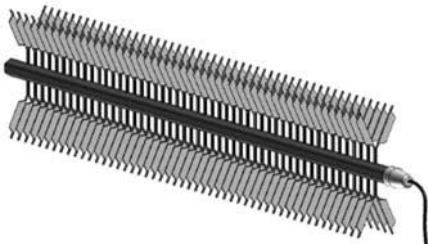

Outer paneling

The standard supply includes panels in aluminum-magnesium alloy 5005, representing the best solution for the resistance to weather agents and for limiting the unit weight: the weight reduction vs. the version in painted galvanized sheet is averagely 32 kg.

Surface treatments on finned coils

An efficient protection against corrosive agents is guaranteed by the copper-copper version, the cataphoresis protection and the use of hydrophile pre-treated aluminum: the protection grade is reported in the mentioned order.

Refrigerants

According to the norm EEC 2037/00, the HTW units can operate with :

- HFC R407C as standard
- HFC R134a (optional)
- HCFC R22 Export non-EEC in the countries signing the Montreal protocol

The unit is supplied: tested and ready to be started up on the site.

Alarms

It reports high and low priority alarms on clean contacts. In case of ADVANCED microprocessor, it is possible to have a subdivision of the alarm type in the terminal board of the electric panel and, generally, it is possible to arrange Custom solutions according to the different supply standards of the phone companies.

Air distribution grilles

The wall-mounted air distributions grilles are made of extruded aluminum, with single row of adjustable fins and accident-prevention protection net on the delivery. In case of Free-Cooling unit, a further net is arranged on the air outlet to prevent the unwished entry of small animals and/or insects.

Tests and Reference Standards**Safety**

The **THX** units have been designed, manufactured and tested according to the directives of the European Union :

- 98/37/EC (former 89/392/EEC, 91/368/EEC, 93/68/EEC)
- 89/336/EEC
- 73/23/EEC

Electric boards

The electric boards comply with
EN 60204-1.

Electro--magnetic compatibility

The **THX** unit complies with the following EMC standards:

- EN 50081-1, Emissions (.Generic emission standard, Part 1: residential, commercial and light industrial., January 1992)
- EN 50082-2, Electro-magnetic compatibility (.Generic emission standard, Part 2: industrial environment., March 1995)

Conformity

Each **THX** unit is supplied complete with test certificate and conformity certificate according to the Directives of the European Union. The units are .CE. marked.



Technical data - @DNOVA - HTX

@DNOVA	HTX	0451	0561	0731	0901	1051	1201	0902	1102	1302
Cooling mode										
Refrigerant	As-hrae	R407C								
Cooling Capacity @27°/40%, 35°	W	4500	5600	7300	8900	10150	11950	9100	10800	13200
Standard Power Supply	V-n-f	230/1/50			400/3/50					
Power Supply (Option 2)	V-n-f	-	400/3/50	400/3/50	230/1/50					
Power Supply (Option 3)	V-n-f	230/1/50 + 230/1/50					400/3/50 + 230/1/50			
Power Supply (Option 4)	V-n-f	230/1/50 + VDC			430/3/50 + VDC			230/1/50 + VDC	430/3/50 + VDC	
Power Supply (Option 5)	V-n-f	-	430/3/50 + VDC	430/3/50 + VDC	230/1/50 + VDC			430/3/50 + VDC	230/1/50 + VDC	
Electrical data										
Total Absorbed Power	W	1390	1880	2520	2960	3490	4350	2780	3650	4700
Total Absorbed Current	A	6,4	8,8	11,6	15,6	17,2	20,6	13,1	17	10,7
FLA	A	13,2	14,5	16,5	21,8	26,7	28	26	28,8	13
LRA	A	36	49	63	81	104	117	43	52	41
Indoor Fan(s) absorbed Power in 230/1/50 execution	W	108	108	310	470	470	470	230	230	230
Indoor Fan(s) absorbed Power in 48 V DC execution (optional)										
Ventilation										
Indoor Air Flow	m ³ /h	1450	1450	2150	3020	3020	3020	2800	2800	2800
Indoor Air Flow during Free Cooling Operations @ 40 Pa	m ³ /h	1320	1320	1980	2810	2810	2810	2650	2650	2650
Full Free Cooling Temperature	°C	16,8	14,4	16	17,6	16,9	14,05	16,8	15,1	12,5
Filtration		EU2	EU2	EU2	EU2	EU2	EU2	EU2	EU2	EU2
Acoustic										
Sound Power Level	dB-A	69	70	70	71	71	71	72	72	72
Sound Pressure Level @10 meters in Free Field	dB-A	42	43	43	44	44	44	45	45	45
Refrigeration circuit										
Type of compressor		Rotary	Scroll	Scroll	Scroll	Scroll	Scroll	Rotary	Scroll	Scrol
Number of refrigerating circuits		1	1	1	1	1	1	2	2	2
Number of compressors		1	1	1	1	1	1	2	2	2
Oil charge per compressor	dm ³	0,44	1	1	1,1	1,1	1,1	0,44	1	1
Indoor Coil Front Surface	m ²	0,3	0,3	0,3	0,38	0,38	0,38	0,37	0,37	0,37
Outdoor Coil Front Surface	m ²	0,36	0,36	0,36	0,56	0,56	0,56	0,55	0,55	0,55
Condenser Air Flow	m ³ /h	3450	3350	3350	5100	5100	4800	5100	5100	4800
Number of condenser's fan		1	1	1	1	1	1	2	2	2
Dimensions and Weight										
Overall dimensions: height H	mm	1580	1580	1580	1630	1630	1630	1630	1630	1630
Overall dimensions: length L	mm	804	804	804	999	999	999	1130	1130	1130
Overall dimensions: depth D	mm	498	498	498	596	596	596	596	596	596
Weight	kg	93,5	101,5	112,5	142,5	146,5	154,5	160,0	175,0	179,0

FLA : Max.operating current

LRA : Pick-up current

Dimensional drawings : mod. THX 0451 - 0561 - 0731

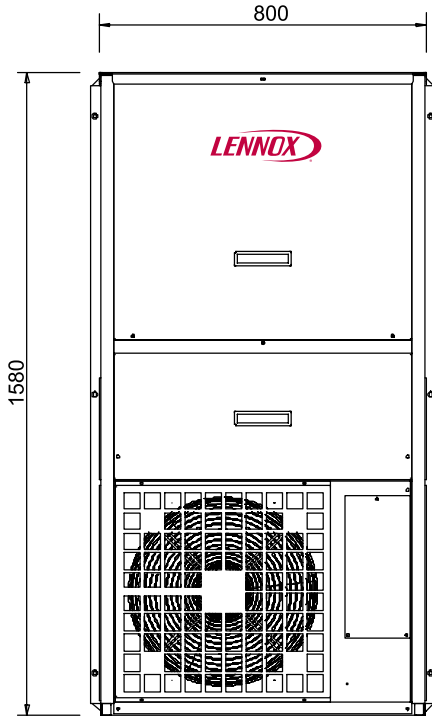

Front view

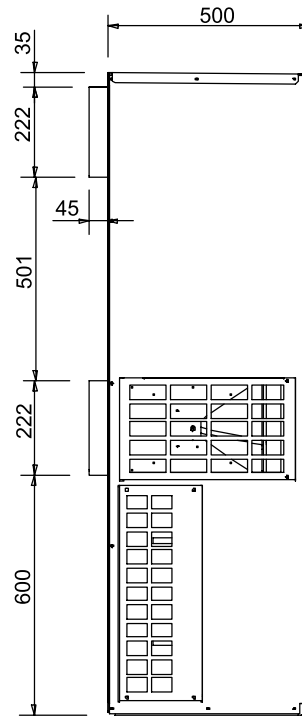

Side view

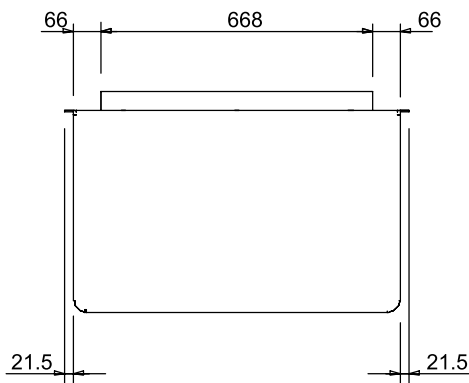

Top view

Dimensional drawings : mod. THX 0901 - 1051 - 1201

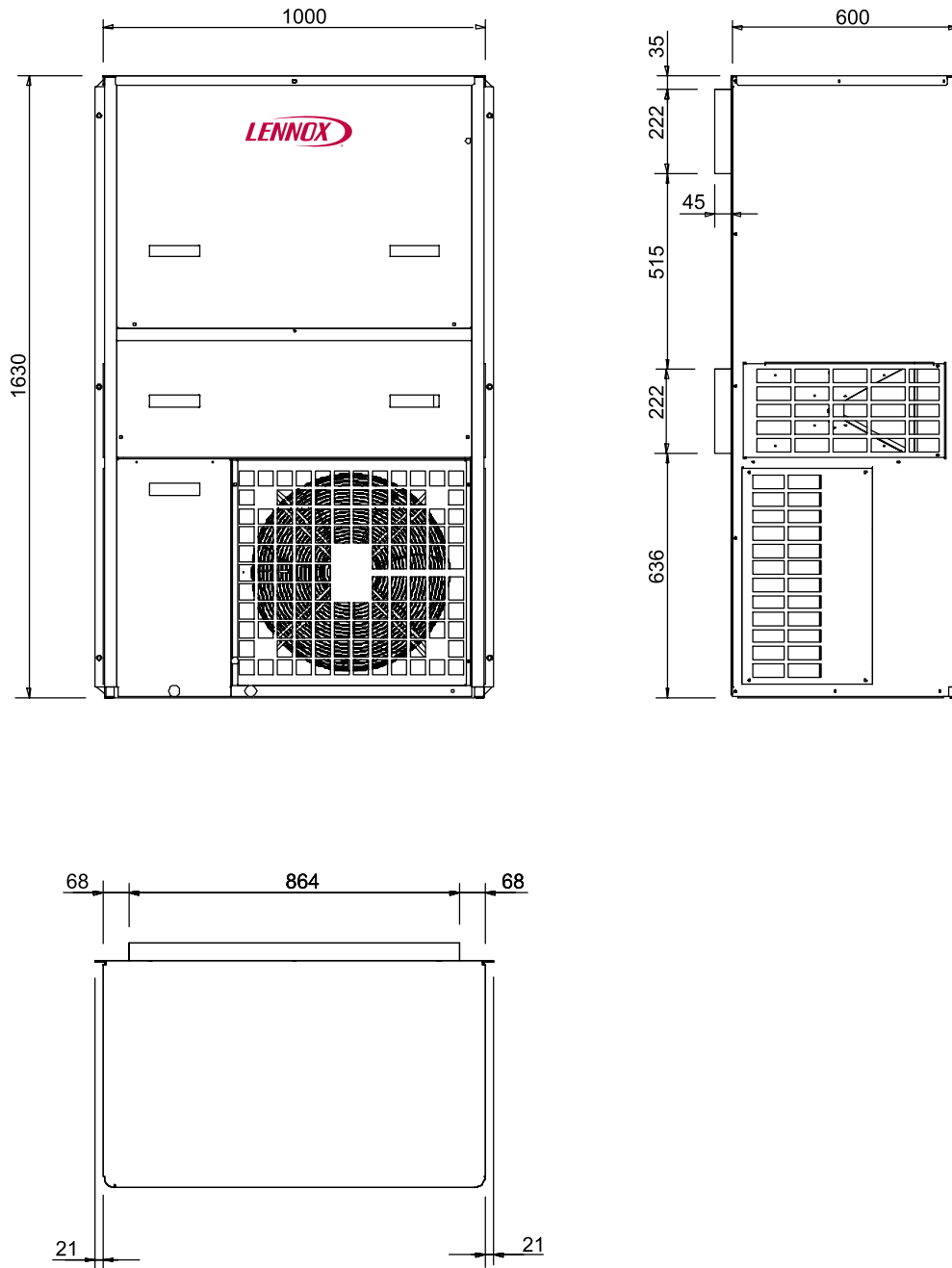

Dimensional drawings : mod. THX 0902 - 1102 - 1302

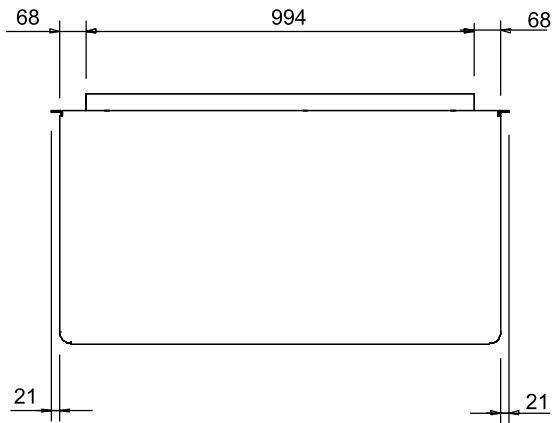
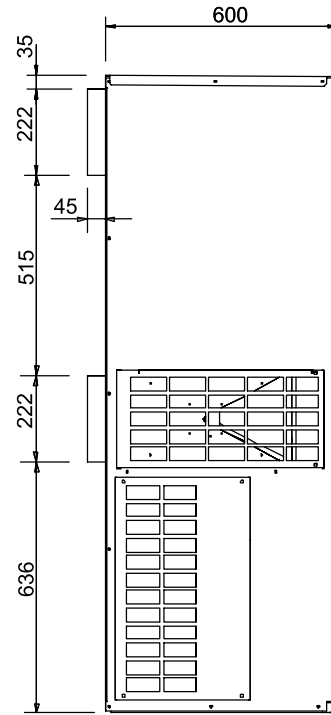
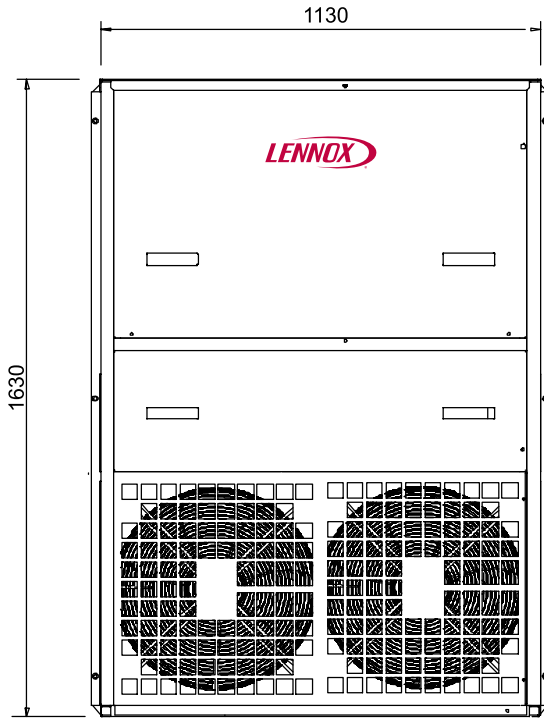



www.lennox europe.com

BELGIUM, LUXEMBOURG
www.lennoxbelgium.com

CZECH REPUBLIC
www.lennox czech.com

FRANCE
www.lennoxfrance.com

GERMANY
www.lennox deutschland.com

NETHERLANDS
www.lennox nederland.com

POLAND
www.lennox polska.com

PORTUGAL
www.lennoxportugal.com

RUSSIA
www.lennoxrussia.com

SLOVAKIA
www.lennox distribution.com

SPAIN
www.lennoxspain.com

UKRAINE
www.lennoxukraine.com

UNITED KINGDOM AND IRELAND
www.lennoxuk.com

OTHER COUNTRIES
www.lennox distribution.com

Due to Lennox's ongoing commitment to quality, the Specifications, Ratings and Dimensions are subject to change without notice and without incurring liability.

Improper installation, adjustment, alteration, service or maintenance can cause property damage or personal injury.

Installation and service must be performed by a qualified installer and servicing agency.



@DNOVA-THX-AGU-0907-E