

APPLICATION GUIDE

COMFAIR

HH

High pressure fan coil unit

840 → 8000 m³/h



COMFAIR HH-AGU-1107-E

lennoxemeia.com

COMFAIR HH

High pressure fan coil units

APPLICATION GUIDE

Ref : COMFAIR HH-AGU-1107-E

HIGH PRESSURE FAN COIL UNITS - HH

General description	2
General data - Eurovent Conditions	4
Technical data	5
Working limits	8
Aeraulic performances	9
Sound power spectrum	13
Air pressure drops for the main accessories	14
Water coil pressure drop diagram	15
Dimensional data	16
Accessories	18

CONTROLLERS

General description	28
-------------------------------	----

*Our company is a member of the Eurovent Certification Program.
The COMFAIR LENNOX fan coil units are tested and rated in accordance with Eurovent certification program.*



Our products comply with the European standards.



Product designed and manufactured under a quality management system certified ISO 9001.

All the technical and technological information contained in this manual, including any drawing and technical descriptions provided by us, remain the property of Lennox and must not be utilised (except in operation of this product), reproduced, issued to or made available to third parties without the prior written agreement of Lennox.

HIGH PRESSURE FAN COIL UNITS - HH

Comfair HH fan coil units are designed to operate against higher external static pressures (from 105 to 260 Pa), and are available in 7 sizes.

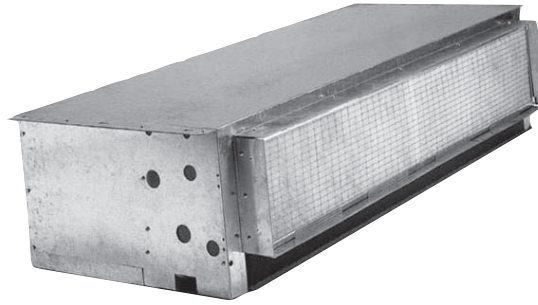

All standard units can be supplied with a complete range of factory or site fitted accessories, allowing a multitude of configurations for all typical applications, for example :

- auxiliary condensate drain pan (UTC)
- air Filter section (SFA)
- auxiliary Coil
- fresh air inlet damper (SSP)
- electric heater (SRE)
- inlet, supply and exhaust air plenums (PAM, RAM et BAM)

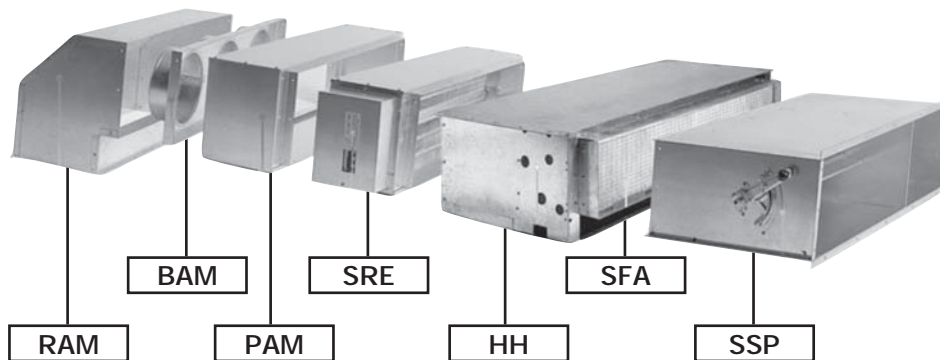

FAN SECTION

Composed of one or two double inlet centrifugal fans with aluminium blades, mounted in horizontal position and statically and dynamically balanced. The electric motor is fitted with overload protection and has three speeds. It is constructed to comply with all relevant International standards, with a capacitor permanently in circuit. Motors are connected directly to the fan shafts and are located on anti-vibration mounts to ensure particularly quiet operation.

CHASSIS

The chassis is manufactured from thick (1mm) galvanised sheet steel.

COILS

Water Heat exchangers are copper tubes with aluminium fins, bonded to the tubes by a mechanical expansion process. Coil connections are of female type antitorsion and headers are fitted with easily accessible air-vents.



CONTROL PANEL

Comfair HH fan coil units must be controlled from a separate remote controller. A large selection of controllers with varying levels of function is available to satisfy most requests.

Options delivered separately : Ambient Thermostats (TA), Minimum water temperature thermostat (TC), Remote (wall mounted) controllers (CD1, CD2/X1, ...).

AIR FILTER

Simple to remove, it comprises a metal frame containing a washable acrylic filter media (filtration efficiency EU 2).

MANUAL FRESH AIR INLET DAMPER

Produced from Alu-Zinc sheet metal, it allows the introduction of fresh air up to a maximum of 30% of the total air volume.

**ELECTRIC HEATER**

Electric heater elements meet all of the relevant International safety standards and are fitted as standard with a safety cut-out thermostat and automatic reset. Heater elements are factory fitted with all electrical wiring and are connected to the control panel via a contactor.

AUXILIARY COIL

In order to offer the best solutions for 4 pipe applications, a supplementary 1 row coil can be ordered factory fitted.

INLET, SUPPLY AND EXHAUST AIR PLENUMS

Plenums are constructed from galvanised sheet steel allow for easy connection to ductwork.



All data are at Eurovent conditions.
<http://www.eurovent-certification.com/>

PROGRAM: FC-2-H

COMFAIR		HH	10	20	30	40	50
Sensible cooling capacity	kW	Min	3,11	4,02	5,63	6,11	7,23
		Med	3,46	5,02	6,93	7,88	9,44
		Max	3,63	5,64	7,36	8,63	11
Total cooling capacity	kW	Min	3,82	5,16	7,21	7,79	8,91
		Med	4,2	6,35	8,66	9,81	11,3
		Max	4,4	7,05	9,2	10,6	13,1
Heating capacity	kW	Min	4,3	6,13	8,66	9,23	11,2
		Med	4,75	7,62	10,5	11,8	14,5
		Max	4,98	8,51	11,2	12,8	16,9
Water pressure drops in cooling	kPa	Min	18,1	19,3	20,8	17,2	16,6
		Med	21,9	29,2	30	27,3	26,9
		Max	24	35,9	33,8	31,9	35,9
Water pressure drops in heating	kPa	Min	16,7	17	17,7	15,1	15,4
		Med	20,2	25,7	25,6	23,9	24,9
		Max	22,2	31,7	28,9	27,9	33,2
Fan electrical power	kW	Min	0,11	0,15	0,3	0,31	0,28
		Med	0,12	0,19	0,32	0,34	0,41
		Max	0,16	0,24	0,32	0,34	0,58
Voltage	V/Ph/Hz	-	230/1/50				
Sound power level	dB(A)	Min	63	53	61	58	62
		Med	67	62	68	65	69
		Max	68	66	70	69	74

PROGRAM: FC-4-H

COMFAIR		HH	10	20	30	40	50
Sensible cooling capacity	kW	Min	2,66	4,02	5,4	5,76	6,89
		Med	2,93	5	6,66	7,44	9,02
		Max	3,1	5,63	7,07	8,04	10,6
Total cooling capacity	kW	Min	3,13	5,12	6,51	7,03	8,31
		Med	3,44	6,3	7,82	8,86	10,6
		Max	3,6	7	8,3	9,57	12,3
Heating capacity	kW	Min	3,61	5,04	7,5	8,23	9,3
		Med	3,98	6,27	8,73	9,93	12
		Max	4,18	7	9,17	10,6	14
Water pressure drops in cooling	kPa	Min	12	14,4	17,7	13,9	14,2
		Med	14,5	21,8	25,2	21,8	23
		Max	15,9	26,8	28	25	30,8
Water pressure drops in heating	kPa	Min	20	11,9	25,3	13,3	15
		Med	24,3	18,4	33,8	19,3	24,9
		Max	26,8	22,9	37	21,7	33,8
Fan electrical power	kW	Min	0,11	0,14	0,3	0,31	0,28
		Med	0,12	0,17	0,32	0,34	0,41
		Max	0,16	0,22	0,32	0,34	0,58
Voltage	V/Ph/Hz	-	230/1/50				
Sound power level	dB(A)	Min	63	53	61	59	61
		Med	67	62	68	66	68
		Max	69	66	70	70	73

2 PIPES SYSTEM

COMFAIR	HH	10	20	30	40	50	60	70
Total cooling capacity ⁽¹⁾	W	3640	7050	9200	10600	13100	27800	50600
	Frig/h	3130	6063	7912	9116	11266	23908	43516
Sensible cooling capacity ⁽¹⁾	W	2870	5640	7360	8630	11000	21100	39500
	Frig/h	2,468	4,85	6,33	7,422	9,46	18,146	33,97
Heating capacity ⁽³⁾	W	4972	8512	11210	12800	16818	32430	60111
	kcal/h	4276	7320	9641	11008	14464	27890	51696
Water flow ⁽¹⁾⁽³⁾	l/h	626	1213	1582	1823	2253	4782	8703
	l/s	0,174	0,337	0,441	0,506	0,626	1,328	2,418
Water pressure drops in cooling ⁽¹⁾	kPa	24	35,9	33,8	31,9	35,9	34	40
	mWG.	2,4	3,7	3,4	3,3	3,7	3,5	4,1
Water pressure drops in heating ⁽³⁾	kPa	22,2	31,7	28,9	27,9	33,2	24	30
	mWG.	2,3	3,2	2,9	2,8	3,4	2,4	3,1
Heating capacity ⁽²⁾	W	8400	14300	18850	21520	28490	54240	100810
	kcal/h	7224	12298	16211	18507	24502	46647	86698
Water flow ⁽²⁾	l/h	722	1230	1621	1850	2450	4664	8670
	l/s	0,201	0,342	0,45	0,514	0,681	1,296	2,408
Water pressure drops in heating ⁽²⁾	kPa	18,3	29,6	27,5	26,1	35,6	20,7	27
	mWG.	1,9	3	2,8	2,7	3,6	2,1	2,8
Electrical heater heating capacity ⁽⁴⁾	W	3000	6000	9000	12000	18000		
	kcal/h	2586	5172	7759	10345	15517		
Electrical heater power input ⁽⁴⁾	A	4,56	9,12	13,67	18,23	27,35		
Electrica heater heating capacity ⁽⁵⁾	W	4500	9000	12000	18000	24000		
	kcal/h	3879	7759	10345	15517	20690		
Electrical heater input current ⁽⁵⁾	A	6,84	13,67	18,23	27,35	36,46		
Air flow ⁽⁶⁾	m ³ /h	837	1423	1951	2131	3002	4678	9250
	m ³ /s	0,233	0,395	0,542	0,592	0,834	1,299	2,569
Fan speed ⁽⁶⁾	rpm	1360	1360	1200	1207	1382	806	822
Sound power level ⁽⁷⁾	dB(A)	68	66	70	69	75	78	81
Motor electrical power ⁽⁸⁾	W	160	240	320	340	580	1320	2600
Motor electrical input ⁽⁸⁾	A	0,72	0,97	1,43	1,51	2,58	5,86	11,54
Electrical supply	V/Ph/Hz	230/1/50						

Above mentioned technical data are calculated at the following operating conditions:

- Maximum fan speed
- Standard unit without ducts (fancoil operating without external back pressure)

- (1) Cooling: entering water temperature 7°C, leaving water temperature 12°C, entering air temperature 27°C W.B.; 19°C D.B.
- (2) Heating: entering water temperature 50°C, same water flow as in cooling, entering air temperature 20°C
- (3) Heating: entering water temperature 70°C, leaving water temperature 60°C, entering air temperature 20°C
- (4) Electric heaters section SRE - B: electric heaters capacities, lower speed cabling (SRE - B supplied as accessory only)
- (5) Electric heaters section SRE - A: electric heaters capacities, high speed cabling (SRE - A supplied as accessory only)
- (6) Air flow and fan speed: fancoil performances with cleaned filter
- (7) Sound power level: sound power measured following ISO 23741
- (8) Electrical data referred to the maximum available speed

2 PIPES SYSTEM

CORRECTION COEFFICIENT FOR DIFFERENT AVAILABLE SPEEDS

COMFAIR	HH	10	20	30	40	50	60	70
Total cooling capacity	1	0,84 min	0,74 min	0,79 min	0,74 min	0,68 min	0,77 min	0,78 min
	2	0,95 med	0,90 med	0,94 med	0,93 med	0,87 med	0,89 med	0,90 med
	3	0,98	0,96	1,00 max	1,00 max	1,00 max	1,00 max	1,00 max
	4	1,00 max	1,00 max	-	-	-	-	-
Sensible cooling capacity	1	0,86 min	0,71 min	0,77 min	0,71 min	0,65 min	0,75 min	0,76 min
	2	0,95 med	0,89 med	0,94 med	0,91 med	0,85 med	0,88 med	0,89 med
	3	0,98	0,95	1,00 max	1,00 max	1,00 max	1,00 max	1,00 max
	4	1,00 max	1,00 max	-	-	-	-	-
Heating capacity	1	0,86 min	0,72 min	0,77 min	0,72 min	0,67 min	0,75 min	0,77 min
	2	0,95 med	0,90 med	0,94 med	0,92 med	0,86 med	0,88 med	0,89 med
	3	0,98	0,96	1,00 max	1,00 max	1,00 max	1,00 max	1,00 max
	4	1,00 max	1,00 max	-	-	-	-	-
Air flow	1	0,81 min	0,63 min	0,69 min	0,63 min	0,56 min	0,69 min	0,70 min
	2	0,93 med	0,85 med	0,91 med	0,89 med	0,80 med	0,84 med	0,85 med
	3	0,97	0,94	1,00 max	1,00 max	1,00 max	1,00 max	1,00 max
	4	1,00 max	1,00 max	-	-	-	-	-

Data indicated as min., med., max. concern the 3 standard speeds set at the factory. Upon customer request other 3 speeds among the 6 speeds available can be connected.

NOTE: The symbol (-) means that for HH30 to HH70, only 3 fan speeds are available. For HH10 and HH20, upon customer request other 3 speeds among the 4 available speeds can be connected.

4 PIPES SYSTEM

COMFAIR	HH	10	20	30	40	50	60	70
Total cooling capacity ⁽¹⁾	W	3600	7000	8300	9570	12300	24950	45550
	Frig/h	3096	6020	7138	8230	10578	21457	39173
Sensible cooling capacity ⁽¹⁾	W	3100	5630	7070	8040	10600	20150	37750
	Frig/h	2666	4842	6080	6914	9116	17329	32465
Heating capacity ⁽²⁾	W	4180	7000	9170	10600	14000	38800	70150
	kcal/h	3595	6020	7886	9116	12040	33368	60330
Water flow in cooling ⁽¹⁾	l/h	619	1205	1428	1646	2116	4291	7835
	l/s	0,172	0,335	0,397	0,457	0,588	1,192	2,176
Water flow in heating ⁽²⁾	l/h	360	602	789	912	1204	3337	6033
	l/s	0,1	0,167	0,219	0,253	0,334	0,927	1,676
Water pressure drops in cooling ⁽¹⁾	kPa	15,9	26,8	28	25	30,8	27	32
	mWG.	1,6	2,7	2,9	2,5	3,1	2,8	3,3
Water pressure drops in heating ⁽²⁾	kPa	26,8	22,9	37	21,7	33,8	33	36
	mWG.	2,7	2,3	3,8	2,2	3,4	3,4	3,7
Heating capacity ⁽³⁾	W	2557	4275	5593	6441	8547	23730	42898
	kcal/h	2204	3686	4822	5553	7368	20457	36981
Water flow ⁽³⁾	l/h	446	746	976	1124	1492	4141	7486
	l/s	0,124	0,207	0,271	0,312	0,414	1,15	2,079
Water pressure drops in heating ⁽³⁾	kPa	46	39	62	36	58	56	62
	mWG.	4,7	4	6,3	3,7	5,9	5,8	6,3
Air flow ⁽⁴⁾	m ³ /h	795	1352	1853	2024	2852	4444	8788
	m ³ /s	0,221	0,376	0,515	0,562	0,792	1,234	2,441
Fan speed ⁽⁴⁾	rpm	1365	1365	1205	1214	1387	810	832
Sound power level ⁽⁵⁾	dB(A)	69	66	70	70	73	78	81
Motor electrical power ⁽⁶⁾	W	162	218	322	340	582	1320	2600
Motor electrical input ⁽⁶⁾	A	0,72	0,97	1,43	1,51	2,58	5,86	11,54
Electrical supply	V/Ph/Hz	230/1/50						

Above mentioned technical data are calculated at the following operating conditions:

- Maximum fan speed
- Standard unit without ducts (fancoil operating without external back pressure)

(1) Cooling: entering water temperature 7°C, leaving water temperature 12°C, entering air temperature 27°C W.B.; 19°C D.B.

(2) Heating: entering water temperature 70°C, leaving water temperature 60°C, entering air temperature 20°C

(3) Heating: entering water temperature 50°C, same water flow as in cooling, entering air temperature 20°C

(4) Air flow and fan speed: fancoil performances with cleaned filter

(5) Sound power level: sound power measured following ISO 23741

(6) Electrical data referred to the maximum available speed

CORRECTION COEFFICIENT FOR DIFFERENT AVAILABLE SPEEDS

COMFAIR	HH	10	20	30	40	50	60	70
Total cooling capacity	1	0,87 min	0,73 min	0,78 min	0,73 min	0,68 min	0,76 min	0,78 min
	2	0,96 med	0,90 med	0,94 med	0,93 med	0,86 med	0,89 med	0,90 med
	3	0,98	0,96	1,00 max	1,00 max	1,00 max	1,00 max	1,00 max
	4	1,00 max	1,00 max	-	-	-	-	-
Sensible cooling capacity	1	0,86 min	0,71 min	0,76 min	0,72 min	0,65 min	0,74 min	0,76 min
	2	0,94 med	0,89 med	0,94 med	0,93 med	0,85 med	0,87 med	0,89 med
	3	0,98	0,96	1,00 max	1,00 max	1,00 max	1,00 max	1,00 max
	4	1,00 max	1,00 max	-	-	-	-	-
Heating capacity	1	0,89 min	0,77 min	0,82 min	0,78 min	0,73 min	0,78 min	0,80 min
	2	0,96 med	0,92 med	0,95 med	0,94 med	0,89 med	0,90 med	0,91 med
	3	0,98	0,97	1,00 max	1,00 max	1,00 max	1,00 max	1,00 max
	4	1,00 max	1,00 max	-	-	-	-	-
Air flow	1	0,81 min	0,63 min	0,69 min	0,63 min	0,56 min	0,69 min	0,70 min
	2	0,93 med	0,85 med	0,91 med	0,89 med	0,80 med	0,84 med	0,85 med
	3	0,97	0,94	1,00 max	1,00 max	1,00 max	1,00 max	1,00 max
	4	1,00 max	1,00 max	-	-	-	-	-

Data indicated as min., med., max. concern the 3 standard speeds set at the factory. Upon customer request other 3 speeds among the 6 speeds available can be connected.

NOTE: The symbol (-) means that for HH30 to HH70, only 3 fan speeds are available. For HH10 and HH20, upon customer request other 3 speeds among the 4 available speeds can be connected.

Maximum entering water temperature: 70°C
 Minimum entering water temperature: +4°C
 Maximum working pressure: 8 Bar

Maximum entering air temperature: 40°C
 Minimum entering air temperature: +4°C

WATER FLOW AND PRESSURE DROP LIMITS, 3R COIL (HH10 TO HH50) AND 4R COIL (HH60 AND HH70)

COMFAIR	HH	10	20	30	40	50	60	70
Minimal water flow	l/h	175	225	275	325	375	825	1400
Minimal water pressure drop	kPa	1,3	1,1	1	1	1	1	1
Maximal water flow	l/h	1300	1850	2275	2700	3150	6900	11575
maximal water pressure drop	kPa	70,8	71,9	70	69,9	70,1	70,4	70,3

Data given for medium water temperature at 9,5°C

WATER FLOW AND PRESSURE DROP LIMITS, 1 ROW COIL (HH10 TO HH50) AND 2R COIL (HH60 AND HH70)

COMFAIR	HH	10	20	30	40	50	60	70
Minimal water flow	l/h	75	125	150	200	225	600	1025
Minimal water pressure drop	kPa	1,2	1	1,3	1	1,2	1,1	1
Maximal water flow	l/h	575	1050	1100	1650	1725	4900	8450
maximal water pressure drop	kPa	68,5	69,7	70	69,2	69,6	70,7	70,2

Data given for medium water temperature at 65°C

3 WAYS VALVE

Using of 2 or 3 ways valves is compulsory when the unit is used for cooling to avoid condensate in the external structure (bearing structure and cabinet). As alternative install a regulating system to stop coil water entering when the fan is off.

MAXIMUM FAN STATIC PRESSURE

When the units is connected with ducts fan air flow is reduced due to the ducting pressure drops.

With very high pressure drops fancoil air flow becomes too low and electric motor which is connected to the fan can be damaged. For this reason we recommend static pressures lower than the maximum limit static pressures indicated in the schedule.

NOTE: When the fancoil is operating with the maximum operating indicated static pressure value, air flow is half in comparison with the unit without ducts at the same working speed. Definitely the static pressure limit corresponds to the back pressure able to half fancoil air flow (as a consequence the fancoil unit performances like heating & cooling capacity, will be reduced of about 50%).

COMFAIR		HH	10	20	30	40	50	60	70
2 pipes system	1	Pa	90 min	80 min	115 min	105 min	135 min	220 min	220 min
	2	Pa	95 med	95 med	130 med	130 med	180 med	240 med	240 med
	3	Pa	100	100	135 max	135 max	205 max	260 max	260 max
	4	Pa	105 max	105 max	-	-	-	-	-
4 pipes system	1	Pa	75 min	70 min	95 min	90 min	110 min	180 min	180 min
	2	Pa	85 med	80 med	115 med	115 med	155 med	210 med	210 med
	3	Pa	90	85	120 max	120 max	180 max	220 max	220 max
	4	Pa	95 max	90 max	-	-	-	-	-

Data indicated as min., med., max. concern the 3 standard speeds set at the factory. Upon customer request other 3 speeds among the 6 speeds available can be connected.

NOTE: The symbol (-) means that for HH30 to HH70, only 3 fan speeds are available. For HH10 and HH20, upon customer request other 3 speeds among the 4 available speeds can be connected.

HH10 - 2 PIPES SYSTEM (3 ROW COIL DATA)

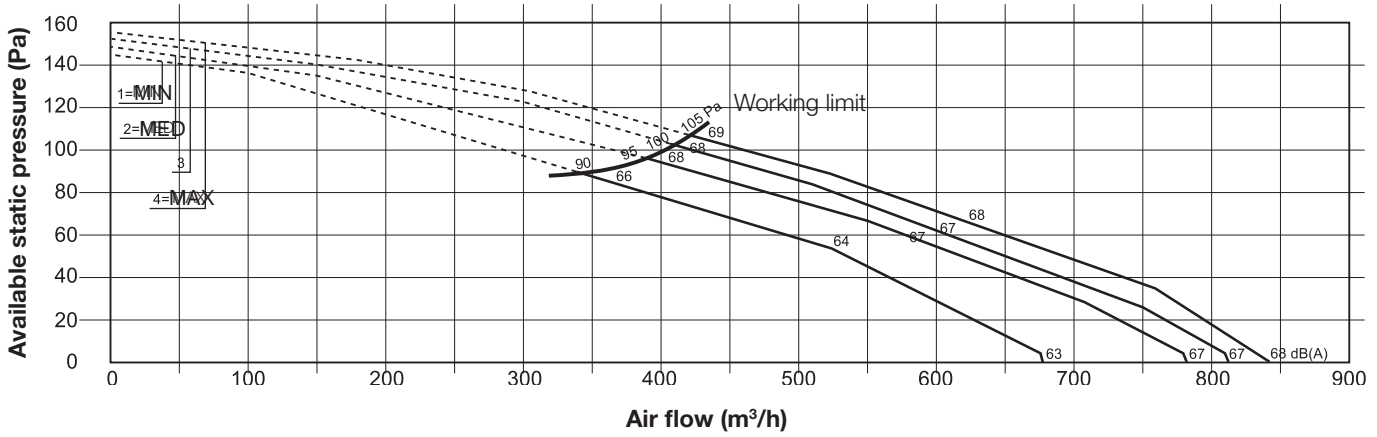

HH20 - 2 PIPES SYSTEM (3 ROW COIL DATA)

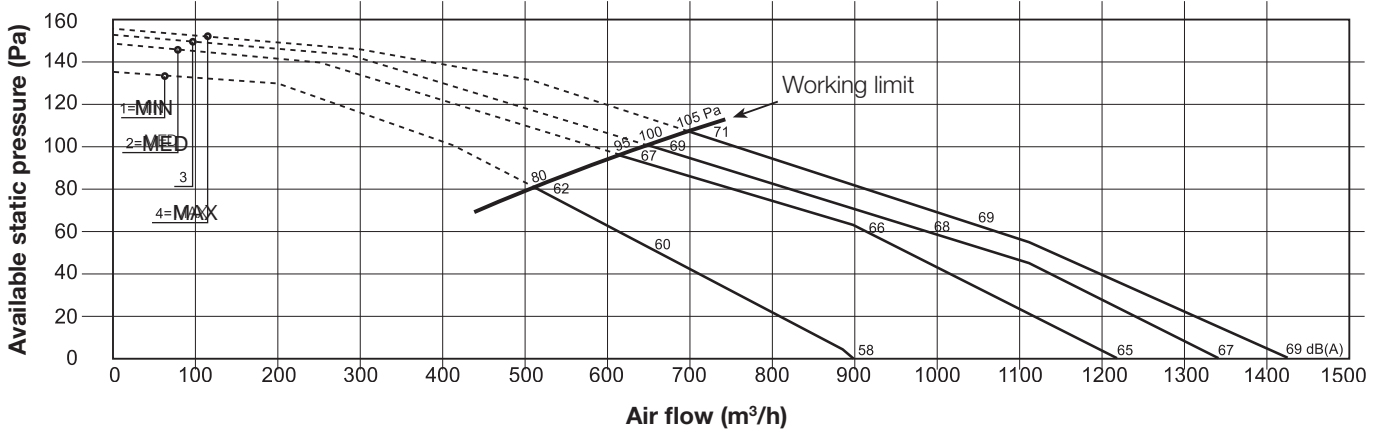

HH30 - 2 PIPES SYSTEM (3 ROW COIL DATA)

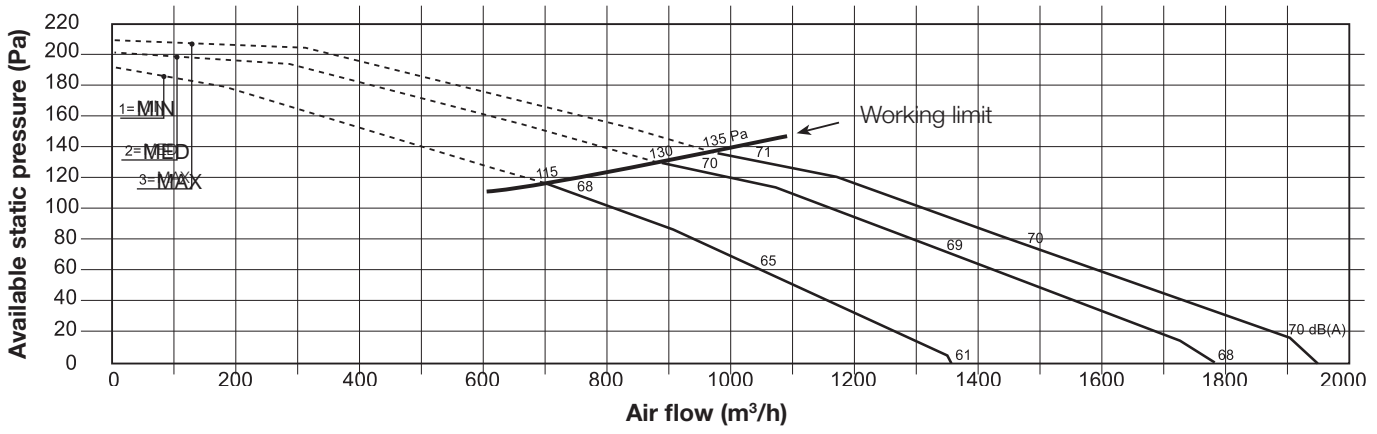

Data indicated as min., med., max. concern the 3 standard speeds set at the factory. Upon customer request other 3 speeds among the 6 speeds available can be connected.

HH40 - 2 PIPES SYSTEM (3 ROW COIL DATA)

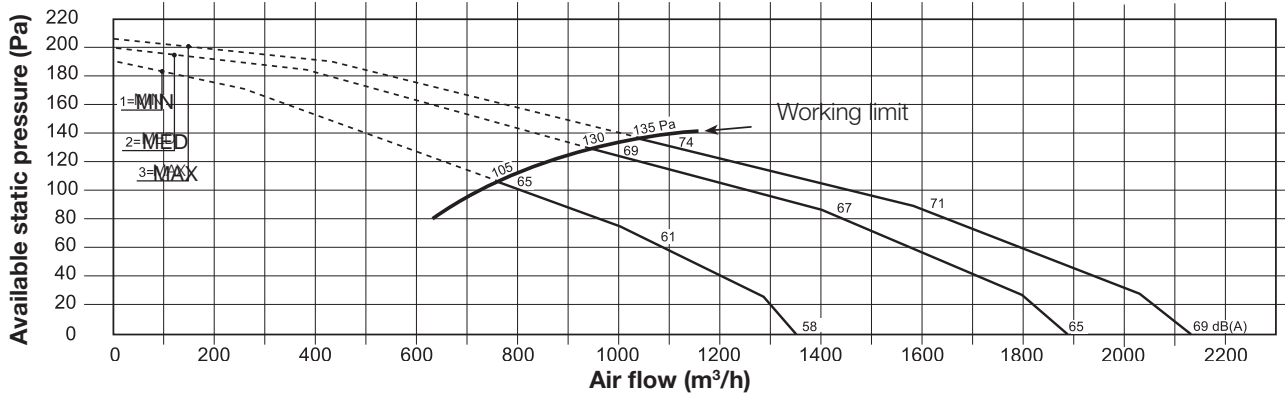

HH50 - 2 PIPES SYSTEM (3 ROW COIL DATA)

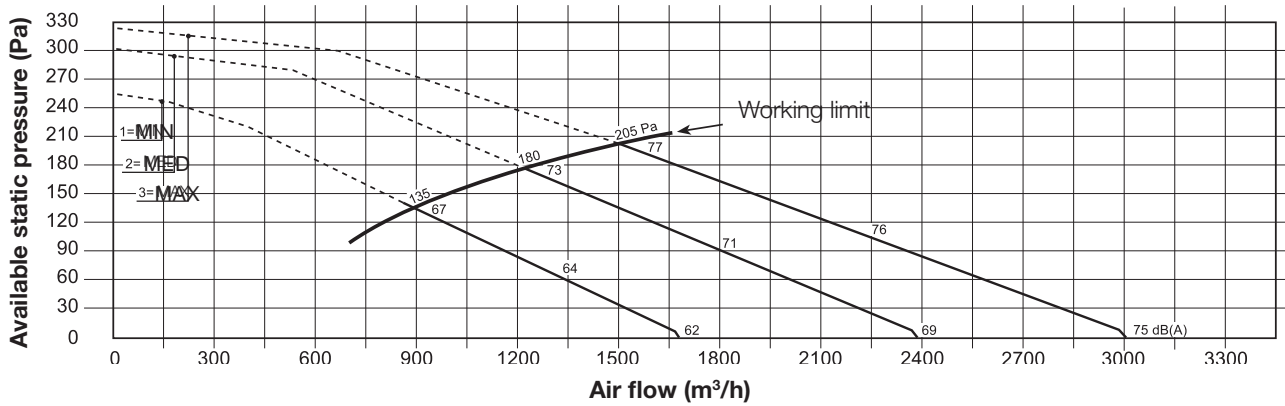

HH60 - 2 PIPES SYSTEM (3 ROW COIL DATA)

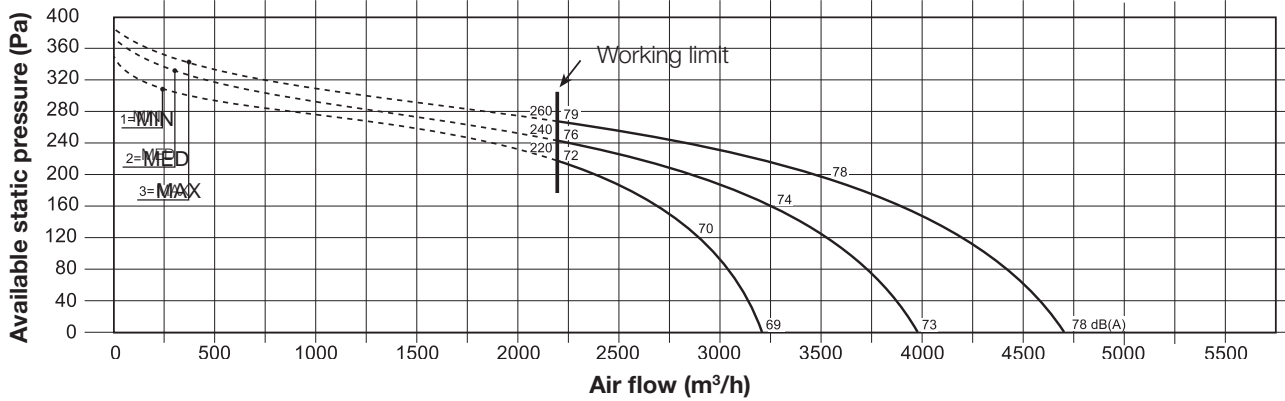

HH70 - 2 PIPES SYSTEM (3 ROW COIL DATA)

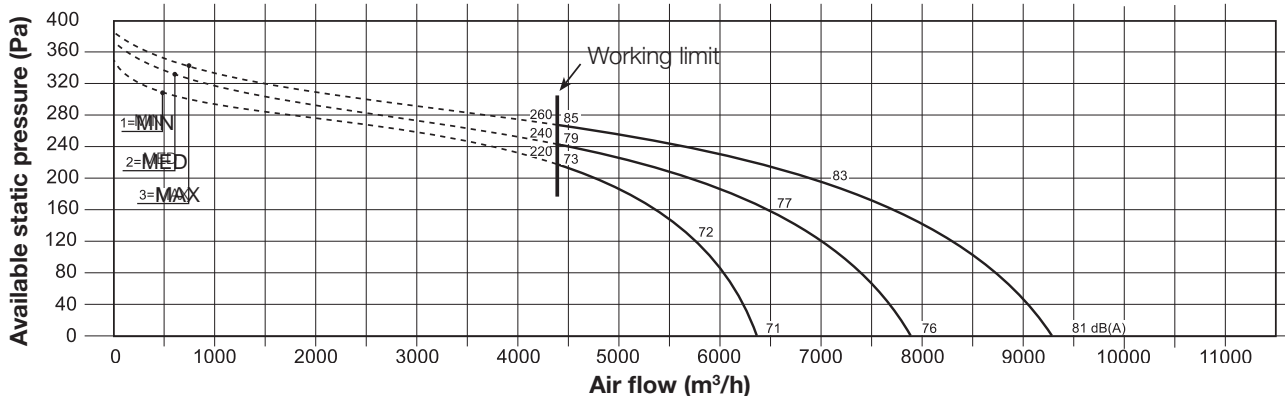

Data indicated as min., med., max. concern the 3 standard speeds set at the factory. Upon customer request other 3 speeds among the 6 speeds available can be connected.

HH10 - 4 PIPES SYSTEM (3 ROW + 1 ROW COIL DATA)

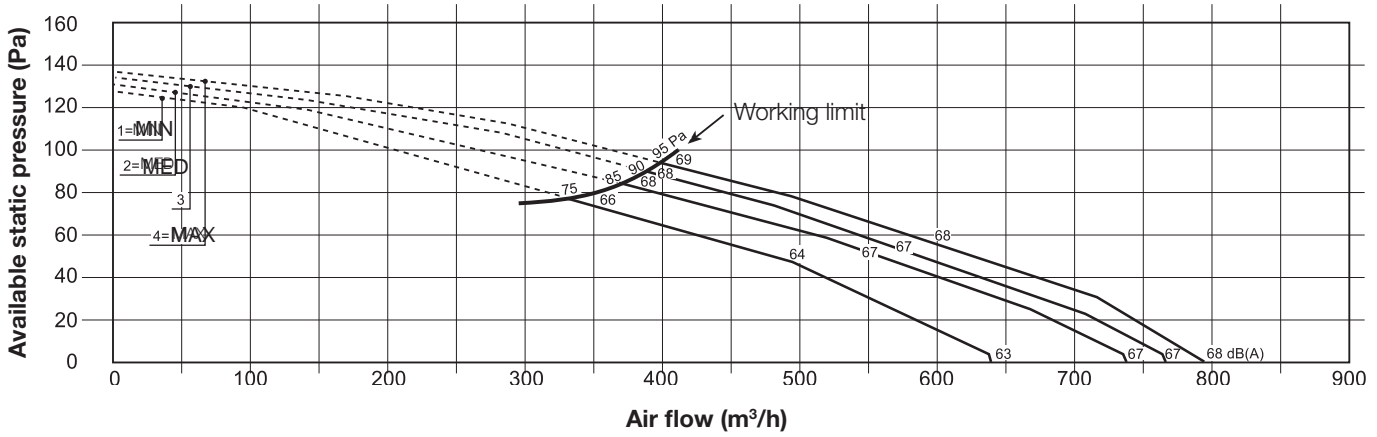

HH20 - 4 PIPES SYSTEM (3 ROW + 1 ROW COIL DATA)

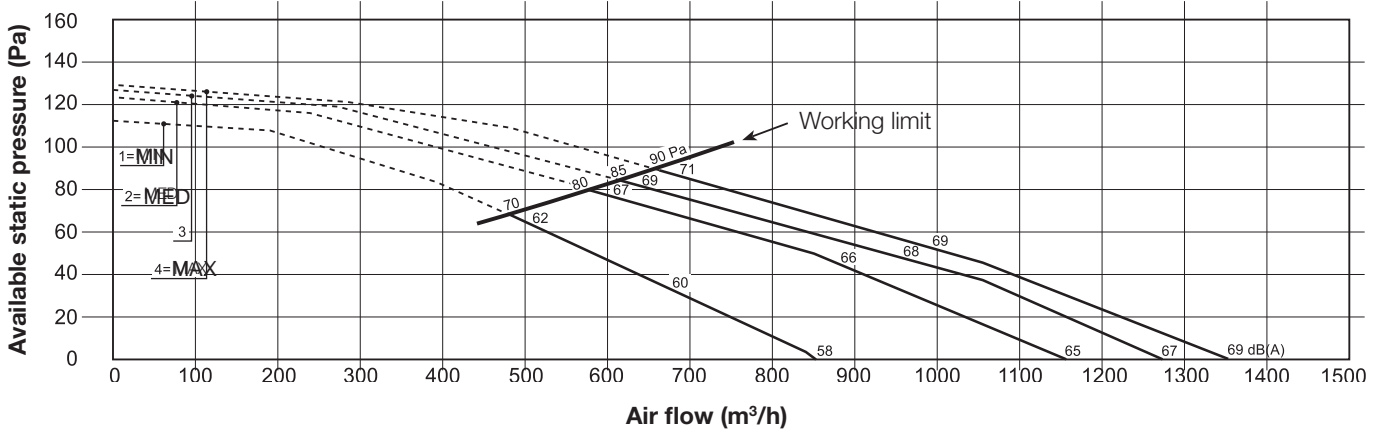

HH30 - 4 PIPES SYSTEM (3 ROW + 1 ROW COIL DATA)

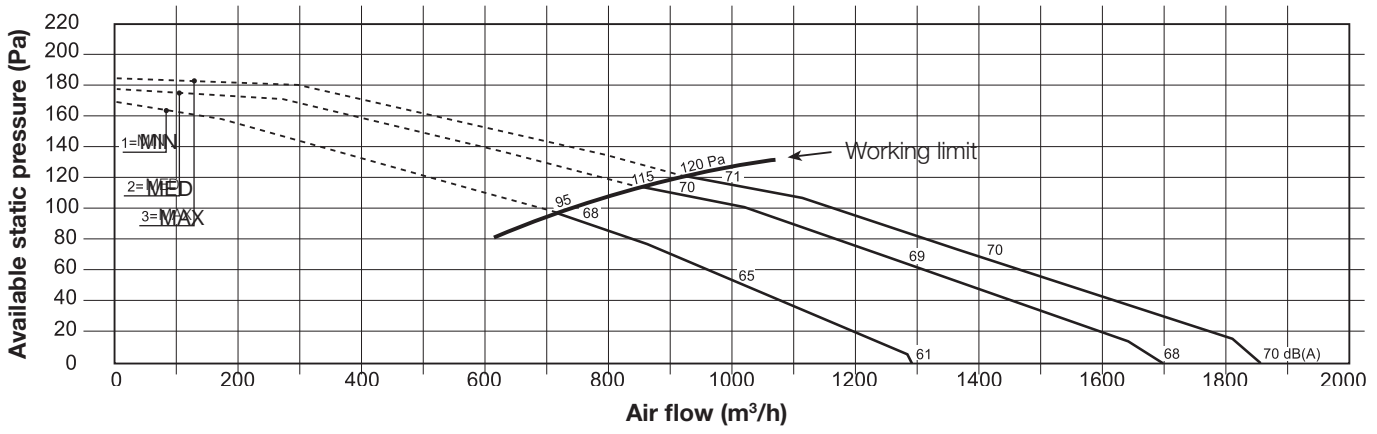

Data indicated as min., med., max. concern the 3 standard speeds set at the factory. Upon customer request other 3 speeds among the 6 speeds available can be connected.

HH40 - 4 PIPES SYSTEM (3 ROW + 1 ROW COIL DATA)

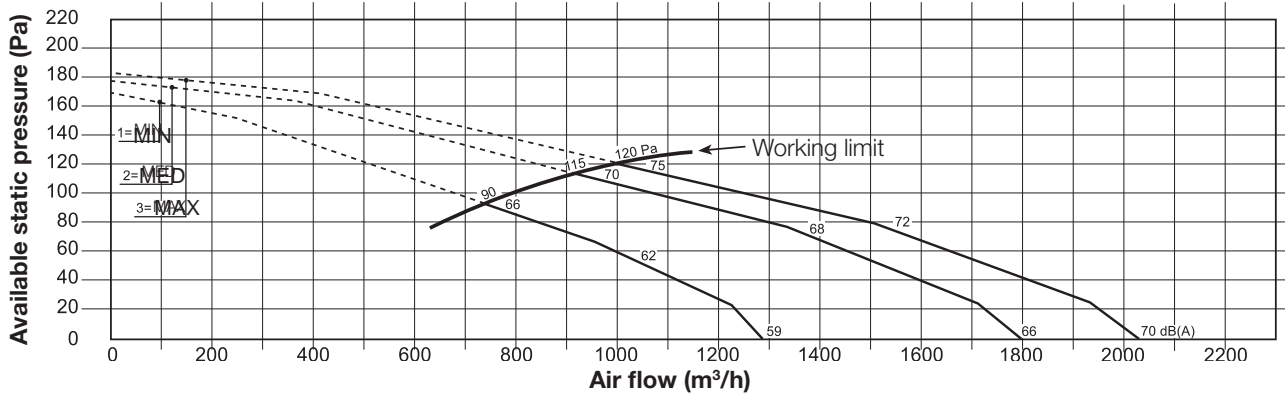

HH50 - 4 PIPES SYSTEM (3 ROW + 1 ROW COIL DATA)

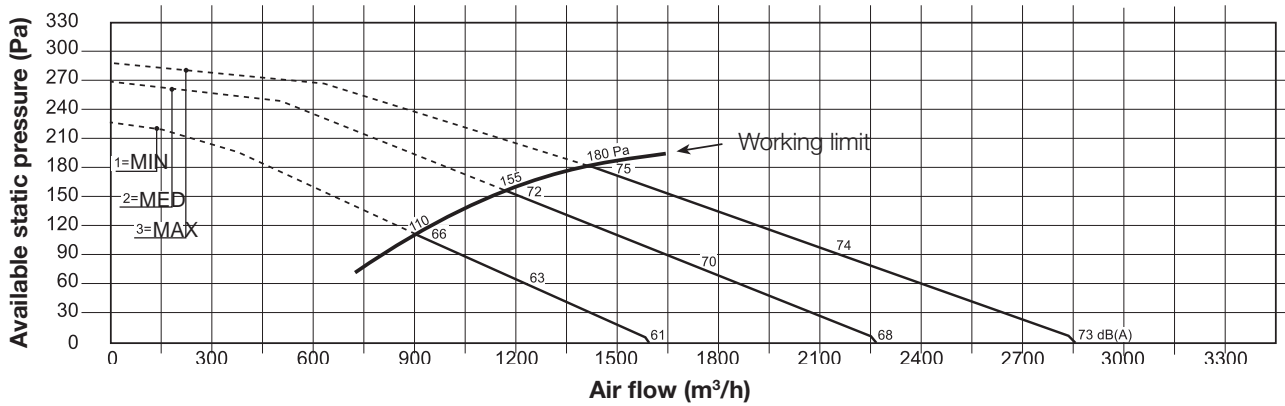

HH60 - 4 PIPES SYSTEM (3 ROW + 1 ROW COIL DATA)

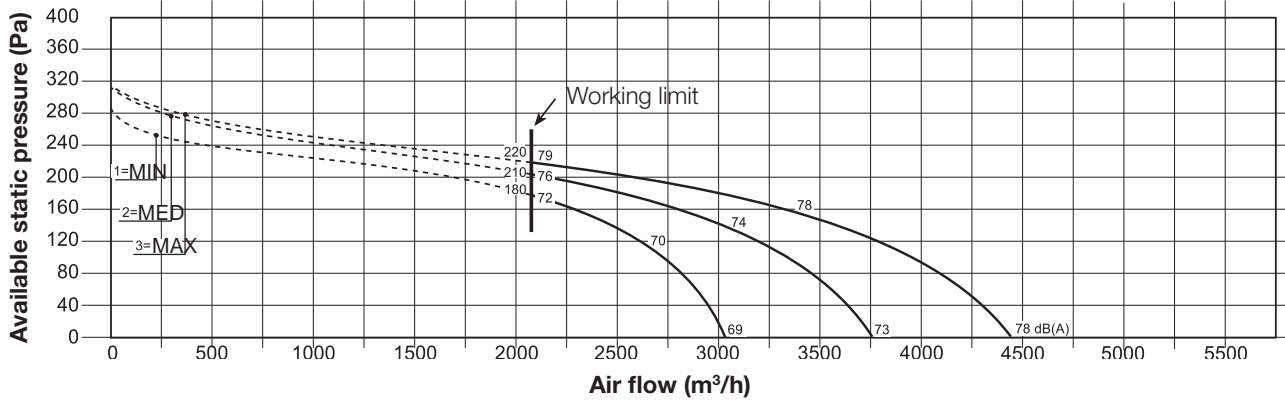

HH70 - 4 PIPES SYSTEM (3 ROW + 1 ROW COIL DATA)

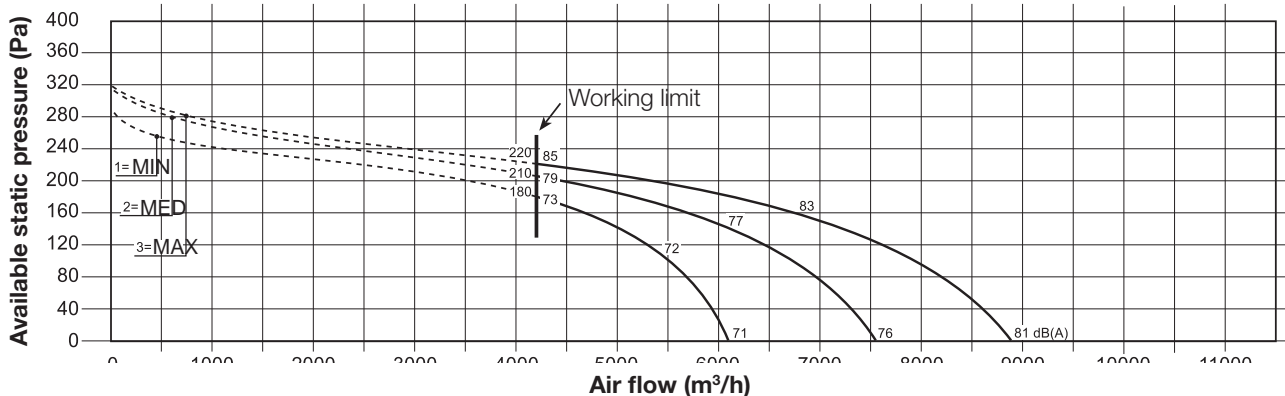

Data indicated as min., med., max. concern the 3 standard speeds set at the factory. Upon customer request other 3 speeds among the 6 speeds available can be connected.

2 PIPES SYSTEM

COMFAIR	Speeds	Std electric wiring (*)	Frequency spectrum - Ref. octave band (Hz)							Total sound power (dB(A))
			125	250	500	1000	2000	4000	8000	
HH10	1	Min	68,1	60,6	59,3	57,9	54,9	52,3	45,9	63
	2	Med	71,4	64,5	62,8	62	59	57	51,5	67
	3		71,4	65,4	63,3	62,5	59,6	57,6	52,6	67,5
	4	Max	71,9	65,7	63,7	62,9	60,1	58,2	53,4	68
HH20	1	Min	57,2	51,4	50,9	47,6	44,8	39,5	32	53
	2	Med	65,2	60	58,7	56,9	54,1	51,3	45,3	62
	3		66,9	61,7	60,1	58,9	56,1	53,8	48,6	64
	4	Max	68,4	63,9	61,8	60,6	58,2	56,2	51,4	66
HH30	1	Min	61,9	57,6	58,7	55,9	53	49,6	42,7	61
	2	Med	67,6	64,2	64,8	64	60,4	52	54	68
	3	Max	68,3	65,6	63,8	66,2	62,1	60,9	56,6	70
HH40	1	Min	67,5	53,5	54,2	51,9	49,6	46	38,6	58
	2	Med	68,3	59,7	61	59,8	57,2	56,2	51,4	65
	3	Max	69,2	63,3	64,1	64,3	61	60,5	56,7	69
HH50	1	Min	63,7	57,8	58,4	58	54,8	48,2	39,1	62
	2	Med	70,4	64,7	63,6	64,2	62,6	59,3	52,2	69
	3	Max	75,6	71,2	68,8	69,6	68,7	66,5	61,1	75
HH60	1	Min	71,3	66,3	68,8	63,4	58,1	54,1	41,6	69
	2	Med	73,8	69	72,7	67,7	62,5	59	48	73
	3	Max	74	73,6	77,3	73,1	68,1	64,8	54,7	78
HH70	1	Min	67,3	67,8	70,6	65,8	61	56,8	44,7	71
	2	Med	75,9	72	75,1	71,2	66,3	62,9	51,9	76
	3	Max	73,7	76,9	79,3	76,7	71,9	68,7	58,9	81

4 PIPES SYSTEM

COMFAIR	Speeds	Std electric wiring (*)	Frequency spectrum - Ref. octave band (Hz)							Total sound power (dB(A))
			125	250	500	1000	2000	4000	8000	
HH10	1	Min	68,1	60,6	59,3	57,9	54,9	52,3	45,9	63
	2	Med	71,4	64,5	62,8	62	59	57	51,5	67
	3		71,9	65,9	63,8	63	60,1	58,1	53,1	68
	4	Max	72,9	66,7	64,7	63,9	61,1	59,2	53,4	69
HH20	1	Min	57,2	51,4	50,9	47,6	44,8	39,5	32	53
	2	Med	65,2	60	58,7	56,9	54,1	51,3	45,3	62
	3		66,9	61,7	60,1	58,9	56,1	53,8	48,6	64
	4	Max	68,4	63,9	61,8	60,9	58,2	56,2	51,4	66
HH30	1	Min	61,9	57,6	58,7	55,9	53	49,6	42,7	61
	2	Med	67,6	64,2	64,8	64	60,4	52	54	68
	3	Max	68,3	65,6	63,8	66,2	62,1	60,9	56,6	70
HH40	1	Min	68,5	54,5	55,2	52,9	50,6	47	39,6	59
	2	Med	69,3	60,7	62	60,8	58,2	57,2	52,4	66
	3	Max	70,2	64,3	65,1	65,3	62	61,5	57,7	70
HH50	1	Min	62,7	56,8	57,4	57	53,8	47,2	38,1	61
	2	Med	69,4	63,7	62,6	63,2	61,6	58,3	51,2	68
	3	Max	73,6	69,2	66,8	67,6	66,7	64,5	59,1	73
HH60	1	Min	71,3	66,3	68,8	63,4	58,1	54,1	41,6	69
	2	Med	73,8	69	72,7	67,7	62,5	59	48	73
	3	Max	74	73,6	77,3	73,1	68,1	64,8	54,7	78
HH70	1	Min	67,3	67,8	70,6	65,8	61	56,8	44,7	71
	2	Med	75,9	72	75,1	71,2	66,3	62,9	51,9	76
	3	Max	73,7	76,9	79,3	76,7	71,9	68,7	58,9	81

Data indicated as min., med., max. concern the 3 standard speeds set at the factory. Upon customer request other 3 speeds among the 6 speeds available can be connected.

Air flow dB(A)	Description of the accessories							
	Fresh air lower section (SSP) With completely open fresh air Lower position	Fresh air lower section (SSP) With completely closed fresh air Lower position	Straight intake/ Supply plenum (PAM)	90° intake/supply plenum (RAM)	Intake/Supply section with spigot section (BAM)	Heating section with electrical heater (SRE)	Standard air filter in medium stemming condition	Standard air filter in limit stemming condition CLEANING IS NECESSARY
COMFAIR HH10								
837	8,7	7,5	1,2	2,8	5,3	50,6	55,1	110
800	7,9	6,9	1,1	2,5	4,8	46,2	50,4	101
700	6,1	5,3	0,8	1,9	3,7	35,4	38,5	77,1
600	4,5	3,9	0,6	1,4	2,7	26	28,3	56,6
500	3,1	2,7	0,4	1	1,9	18	19,7	39,3
400	2	1,7	0,3	0,6	1,2	11,5	12,6	25,2
330	1,3	1,2	-	0,4	0,8	7,9	8,6	17,1
COMFAIR HH20								
1423	9,3	8,1	1,2	2,9	8,4	52,1	56,7	113
1400	9	7,8	1,2	2,8	8,1	50,4	54,9	110
1200	6,6	5,7	0,9	2,1	6	37	40,3	80,7
1000	4,6	4	0,6	1,4	4,1	25,7	28	56
800	2,9	2,5	0,4	0,9	2,7	16,5	17,9	35,9
600	1,6	1,4	-	0,5	1,5	9,3	10,1	20,2
400	0,7	0,6	-	-	0,7	4,1	4,5	9
COMFAIR HH30								
1951	14,1	12,2	1,6	4,4	15,8	59,5	64,9	130
1800	12	10,4	1,4	3,8	13,5	50,7	55,2	110
1600	9,5	8,2	1,1	3	10,6	40	43,6	87,3
1400	7,2	6,3	0,8	2,3	8,2	30,6	33,4	66,8
1200	5,3	4,6	0,6	1,7	6	22,5	24,5	49,1
1000	3,7	3,2	0,4	1,2	4,2	15,6	17	34,1
800	2,4	2,1	0,3	0,7	2,7	10	10,9	21,8
650	1,6	1,4	-	0,5	1,8	6,6	7,2	14,4
COMFAIR HH40								
2131	10,9	9,5	1,3	3,4	10,7	45,6	49,7	99,4
2000	9,6	8,3	1,2	3	9,4	40,2	43,8	87,6
1800	7,8	6,8	0,9	2,5	7,6	32,5	35,5	70,9
1600	6,1	5,3	0,7	1,9	6	25,7	28	56
1400	4,7	4,1	0,6	1,5	4,6	19,7	21,5	42,9
1200	3,5	3	0,4	1,1	3,4	14,5	15,8	31,5
1000	2,4	2,1	0,3	0,8	2,4	10	10,9	21,9
800	1,5	1,3	-	0,5	1,5	6,4	7	14
650	1	0,9	-	0,3	1	4,2	4,6	9,2
COMFAIR HH50								
3002	15,4	13,4	1,6	4,4	21,8	57	62,1	124
2600	11,6	10,1	1,2	3,3	16,4	42,7	46,6	93,1
2200	8,3	7,2	0,9	2,4	11,7	30,6	33,3	66,7
1800	5,5	4,8	0,6	1,6	7,8	20,5	22,3	44,6
1400	3,4	2,9	0,3	1	4,7	12,4	13,5	27
1000	1,7	1,5	-	0,5	2,4	6,3	6,9	13,8
800	1,1	1	-	0,3	1,5	4	4,4	8,8
COMFAIR HH60								
4678	8,5	7,4	0,9	2,5	13,7	27,6	30,1	60,1
4500	7,9	6,8	0,9	2,3	12,7	25,5	27,8	55,6
4000	6,2	5,4	0,7	1,8	10	20,2	22	43,9
3500	4,8	4,1	0,5	1,4	7,7	15,4	16,8	33,6
3000	3,5	3	0,4	1	5,6	11,3	12,4	24,7
2500	2,4	2,1	0,3	0,7	3,9	7,9	8,6	17,2
2000	1,6	1,4	-	0,5	2,5	5	5,5	11
1600	1	0,9	-	0,3	1,6	3,2	3,5	7
COMFAIR HH70								
9250	13,7	11,9	1,4	4	12,4	43,8	47,8	95,5
9000	12,9	11,2	1,3	3,8	11,7	41,5	45,2	90,4
8200	10,7	9,3	1,1	3,1	9,7	34,4	37,5	75,1
7400	8,7	7,6	0,9	2,5	7,9	28	30,6	61,1
6600	6,9	6	0,7	2	6,3	22,3	24,3	48,6
5800	5,4	4,7	0,6	1,6	4,9	17,2	18,8	37,5
5000	4	3,5	0,4	1,2	3,6	12,8	14	27,9
4200	2,8	2,4	0,3	0,8	2,6	9	9,8	19,7
3400	1,8	1,6	-	0,5	1,7	5,9	6,5	12,9
3200	1,6	1,4	-	0,5	1,5	5,2	5,7	11,4

STANDARD COIL (Ref. water medium temperature 9,5°C)

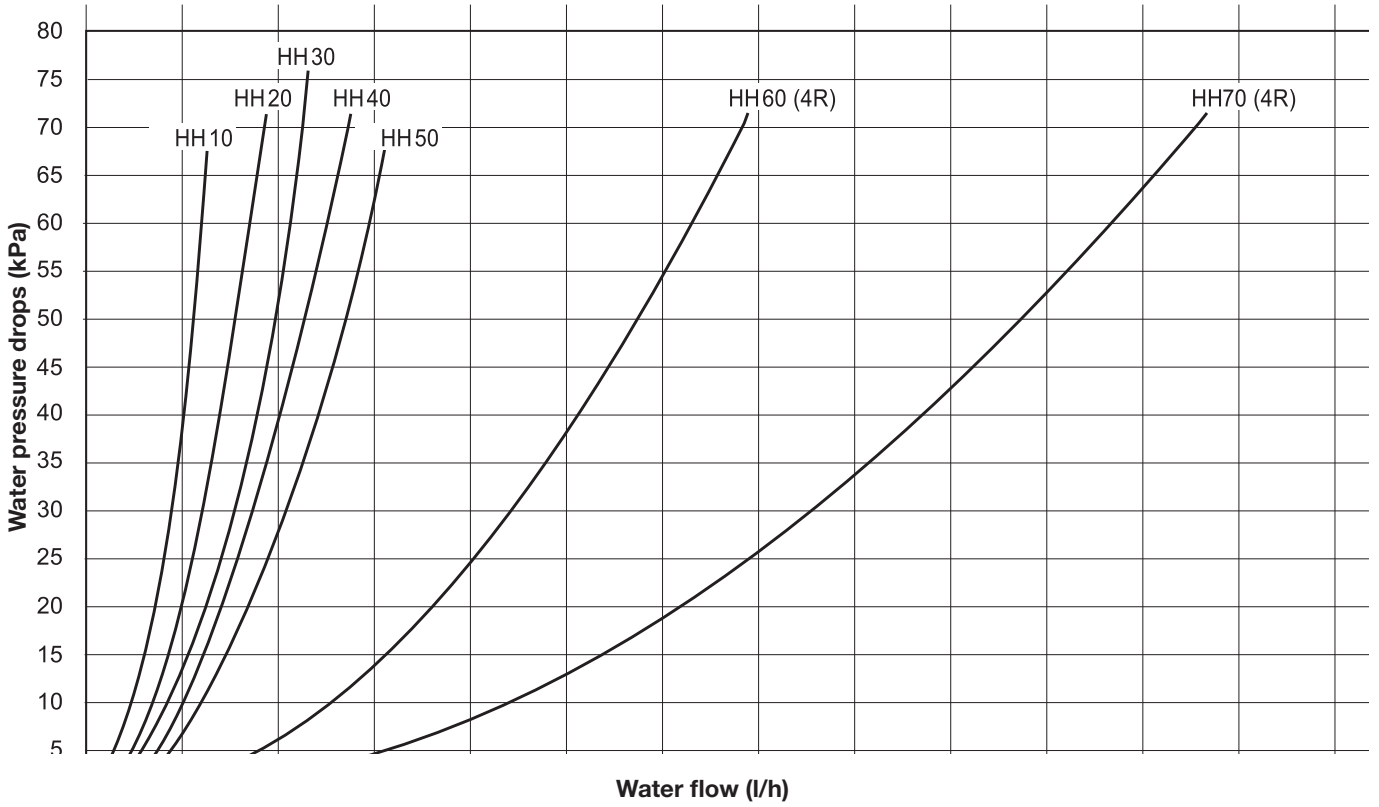

AUXILIARY COIL (Ref. water medium temperature 65°C)

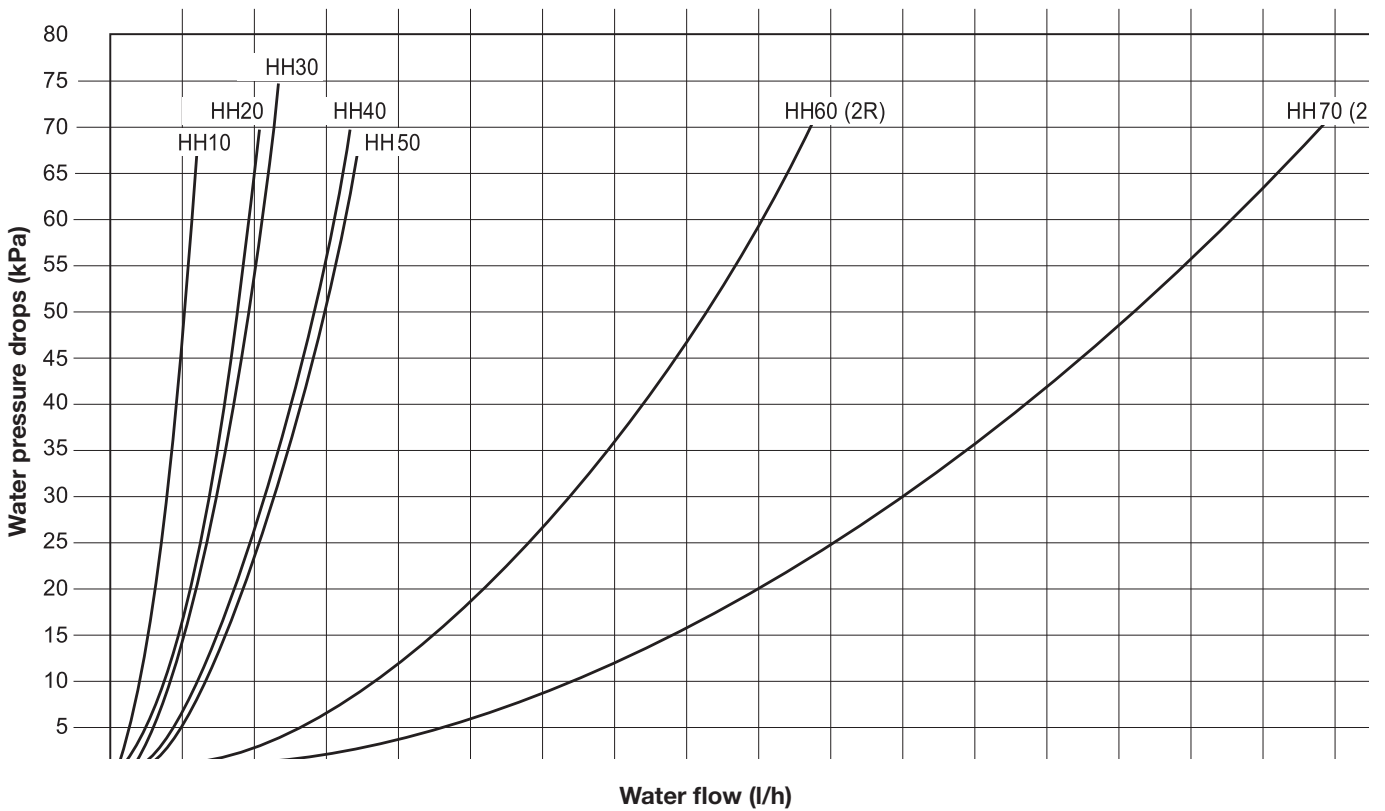

GENERAL DIMENSIONS - 2 PIPES SYSTEM

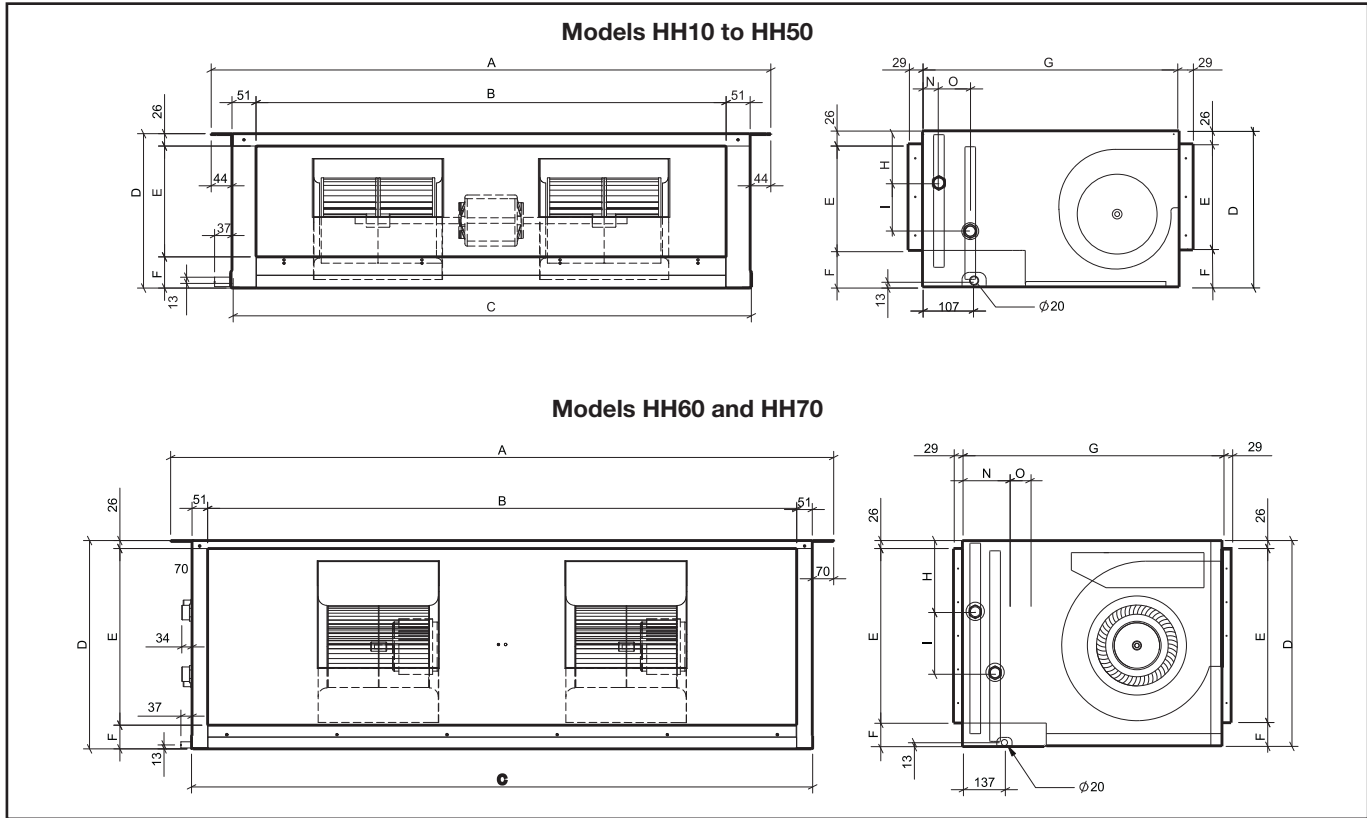

COMFAIR		HH	10	20	30	40	50	60	70	
Fans motor number		nr	1-1	2-1	2-1	2-1	2-1	1-1	2-2	
Coil used for both cooling and heating	Rows number	nr	3						4	
	Finned pack length	mm	523	873	973	1213		1900		
	Number of pipes per row	nr	11		12		14	26		
	Fin spacing	mm	2,1							
	Number of feeding circuits	nr	3	4	5	6	8	16	26	
	Shape	mmxmm	25x22							
	Finned pack depth	mm	66						88	
	Frontal surface	m ²	0,144	0,240	0,292	0,364	0,425	0,788	1,235	
	Total surface of fins	m ²	8,128	13,567	16,495	20,564	23,991	59,407	93,053	
	Water content	liter	1,36	2,18	2,63	3,25	3,79	9,38	14,44	
	Hydraulic connections (Ø male gas)	Ø	1/2"		3/4"		1"	1"1/4	1"1/2	
Unit general features	A	mm	738	1088	1188	1428	1428	1481	2168	
	B	mm	548	898	998	1238	1238	1239	1926	
	C	mm	650	1000	1100	1340	1340	1341	2028	
	D	mm	300		325		375	675		
	E	mm	232					275	575	
	F	mm	41		65		75			
	G	mm	533						852	
	H	mm	96		107		133	235		
	I	mm	100						200	
	N	mm	35						43	
	O	mm	65							
	Net weight	kg	28	36	41	46	57	117	192	

GENERAL DIMENSIONS - 4 PIPES SYSTEM

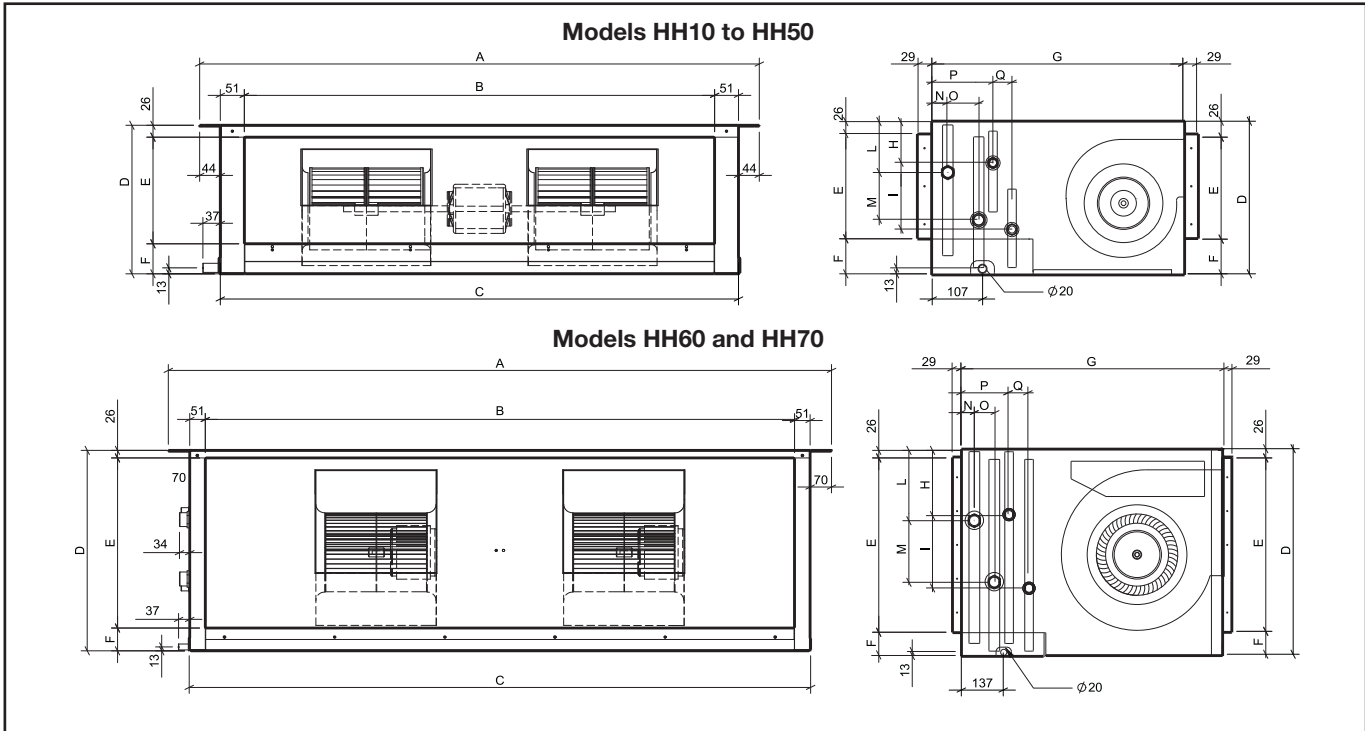

COMFAIR		HH	10	20	30	40	50	60	70	
Fans motor number		nr	1-1	2-1	2-1	2-1	2-1	1-1	2-2	
Coil used for cooling	Rows number	nr	3						4	
	Finned pack length	mm	523	873	973	1213	1213	1213	1900	
	Number of pipes per row	nr	11		12		14		26	
	Fin spacing	mm	2							
	Number of feeding circuits	nr	3	4	5	6	8	16	26	
	Shape	mmxmm	25x22							
	Finned pack depth	mm	66						88	
	Frontal surface	m ²	0,144	0,240	0,292	0,364	0,425	0,788	1,235	
	Total surface of fins	m ²	8,128	13,567	16,495	20,564	23,991	59,407	93,053	
	Water content	liter	1,36	2,18	2,63	3,25	3,79	9,38	14,44	
Hydraulic connections (Ø male gas)	Ø	1/2"		3/4"		1"		1"1/4	1"1/2	
Coil used for heating	Rows number	nr	1						2	
	Finned pack length	mm	523	873	973	1213				1900
	Number of pipes per row	nr	11		12		14		26	
	Fin spacing	mm	2,1							
	Number of feeding circuits	nr	1	2		3		10	16	
	Shape	mmxmm	25x25							
	Finned pack depth	mm	25							
	Frontal surface	m ²	0,144	0,240	0,292	0,364	0,425	0,788	1,235	
	Total surface of fins	m ²	2,709	4,522	5,498	6,855	7,997	29,704	46,527	
	Water content	liter	0,45	0,73	0,88	1,08	1,26	4,69	7,22	
Hydraulic connections (Ø male gas)	Ø	1/2"				3/4"		1"	1"1/4	
Unit general features	A	mm	738	1088	1188	1428	1428	1481	2168	
	B	mm	548	898	998	1238	1238	1239	1926	
	C	mm	650	1000	1100	1340		1341	2028	
	D	mm	300		325		375		675	
	E	mm	232						275	
	F	mm	41		65		75			
	G	mm	533						852	
	H	mm	96		107		133		235	
	I	mm	100						200	
	L	mm	75		87		113		213	
	M	mm	140						240	
	N	mm	35						42	
	O	mm	95						114	
	P	mm	35				32		43	
	Q	mm	40						65	
	Net weight	kg	30	38	44	49	61	130	210	

SFA (AIR FILTER SECTION)

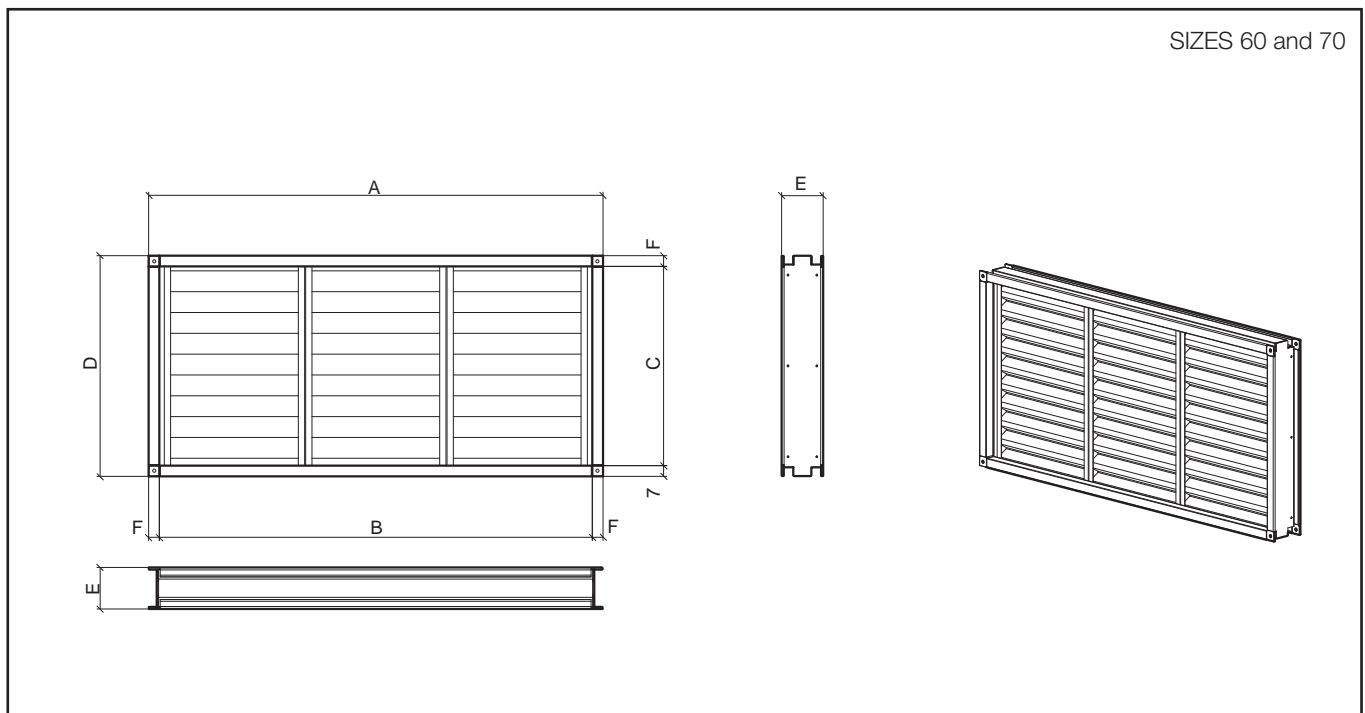
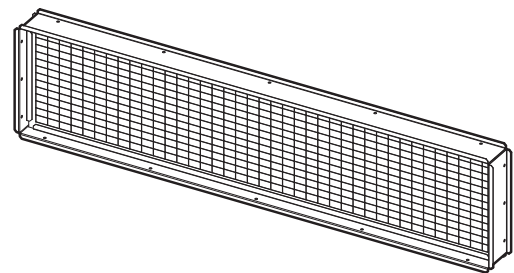
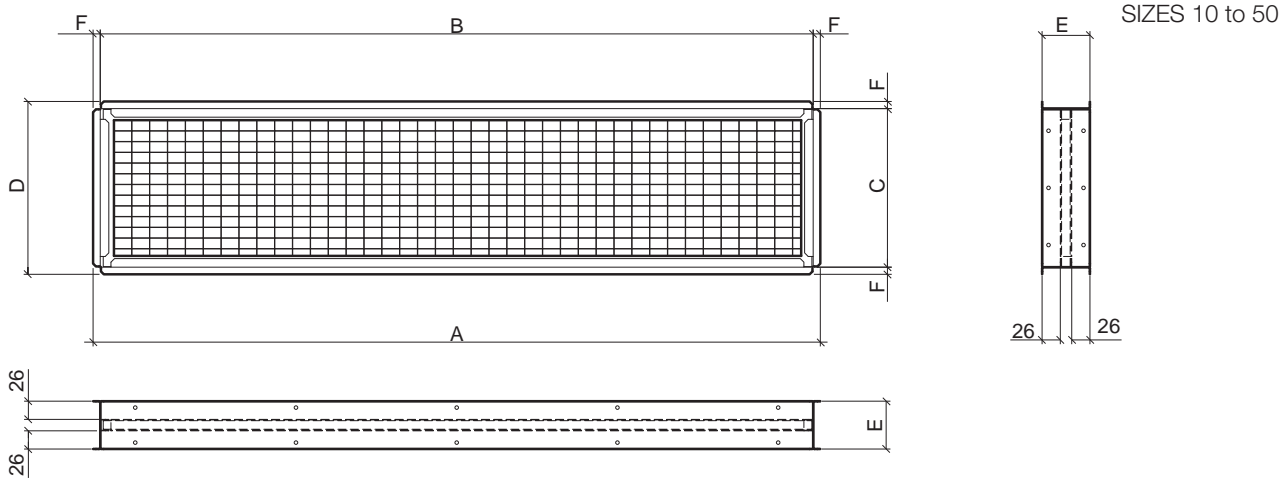

COMFAIR	HH	10	20	30	40	50	60	70
A	mm	566	918	1018	1258	1258	1290	1985
B	mm	546	898	998	1238	1238	1230	1924
C	mm	195	195	222	222	272	568	568
D	mm	215	215	242	242	292	625	625
E	mm	67	67	67	67	67	118	118
F	mm	10	10	10	10	10	31	31

SSP (SECTION WITH FRESH AIR LOUVER - MANUAL)

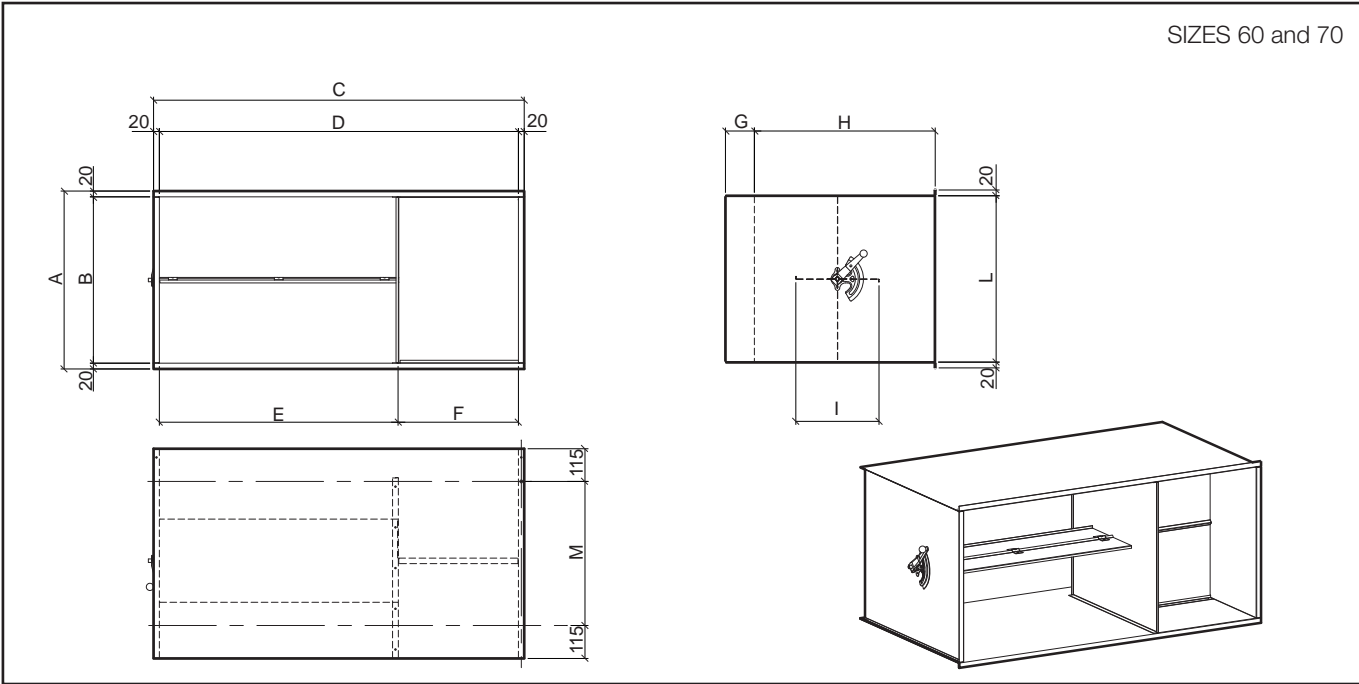
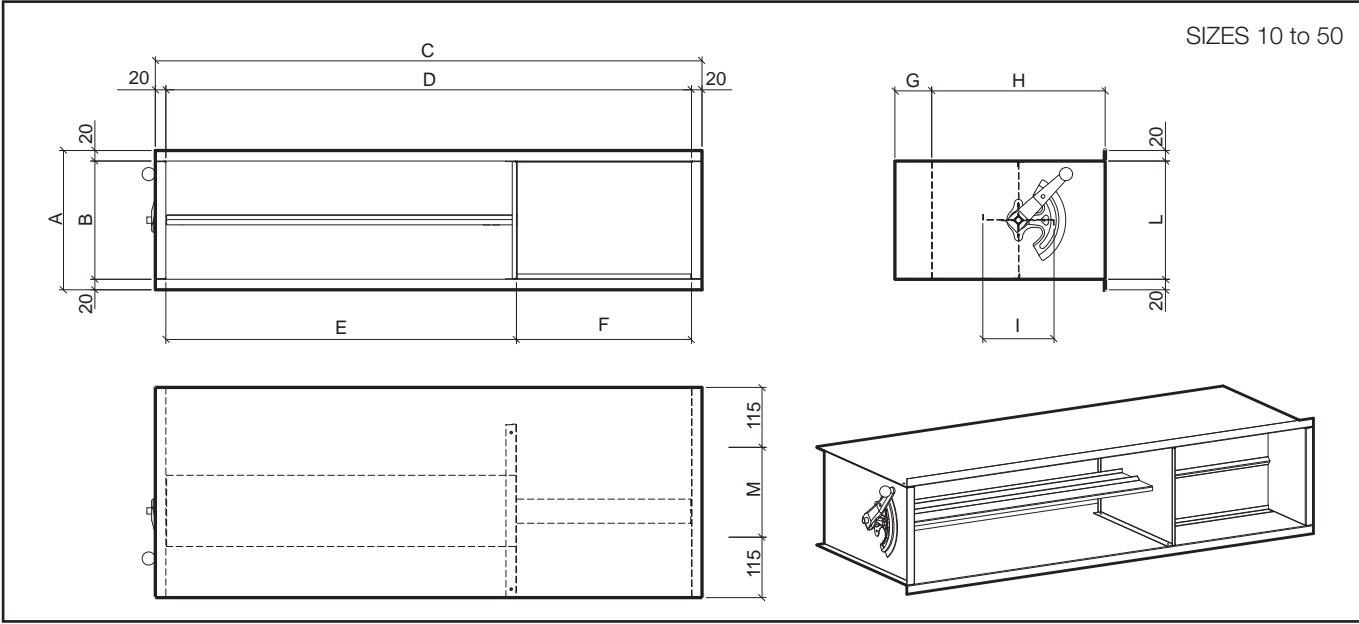

COMFAIR	HH	10	20	30	40	50	60	70
A	mm	240	240	265	265	310	615	725
B	mm	200	200	225	225	270	575	575
C	mm	590	940	1040	1280	1280	1280	1969
D	mm	550	900	1000	1240	1240	1240	1929
E	mm	365	600	665	825	825	825	642
F	mm	185	300	335	415	415	415	1286
G	mm	70	70	70	70	70	100	100
H	mm	330	330	330	330	330	625	625
I	mm	136	136	136	136	136	288	288
L	mm	200	200	225	225	275	575	575
M	mm	170	170	170	170	170	498	498

PAM (STRAIGHT PLENUM: INTAKE)

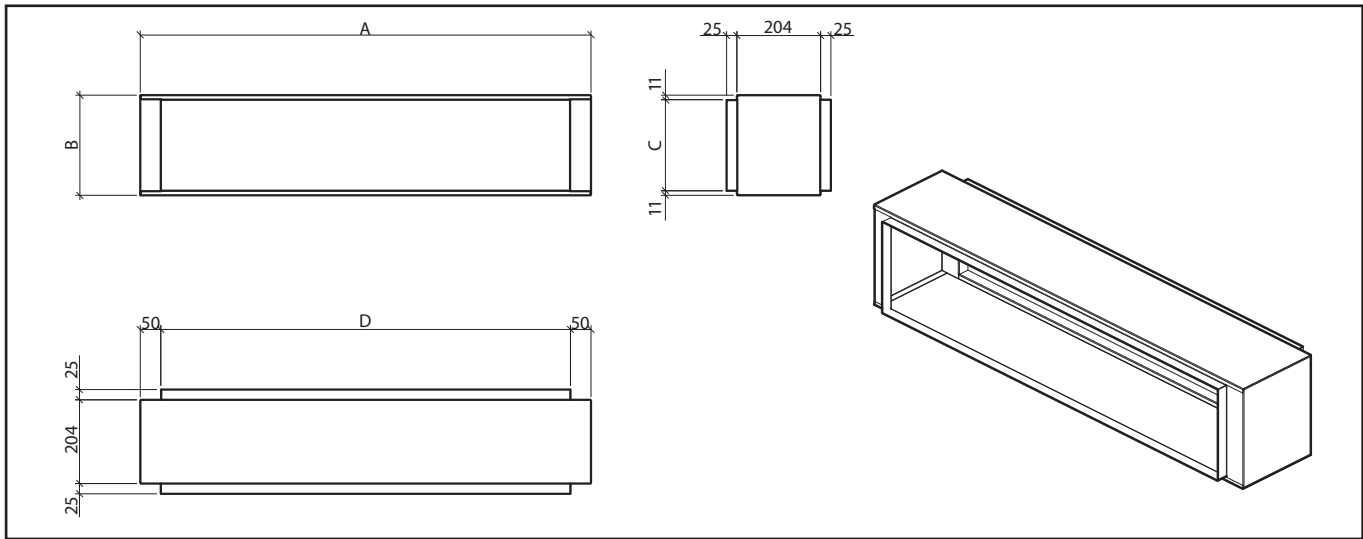

COMFAIR	HH	10	20	30	40	50	60	70
A	mm	648	998	1098	1338	1338	1342	2026
B	mm	219	219	244	244	294	595	595
C	mm	197	197	222	222	272	572	572
D	mm	548	898	998	1238	1238	1242	1926

PAM (STRAIGHT PLENUM: SUPPLY)

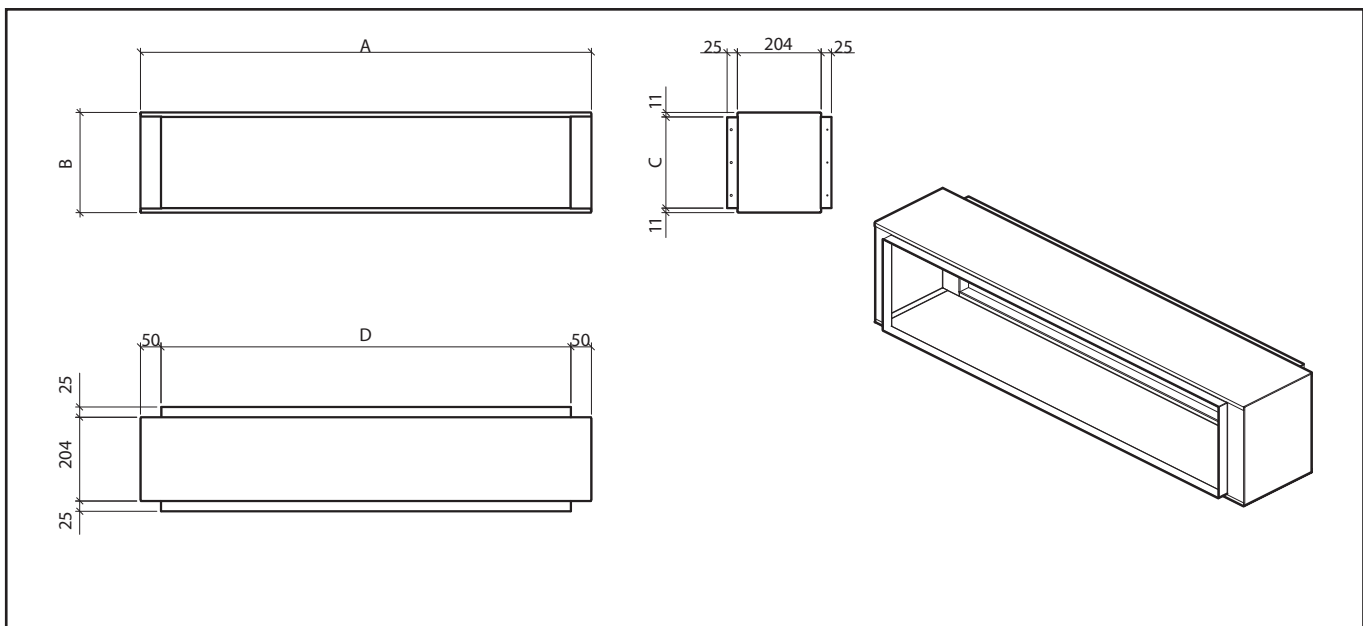

COMFAIR	HH	10	20	30	40	50	60	70
A	mm	648	998	1098	1338	1338	1342	2026
B	mm	219	219	244	244	294	416	416
C	mm	197	197	222	222	272	394	394
D	mm	548	898	998	1238	1238	1242	1926

SRE (HEATING SECTION WITH ELECTRIC HEATER - 380V)

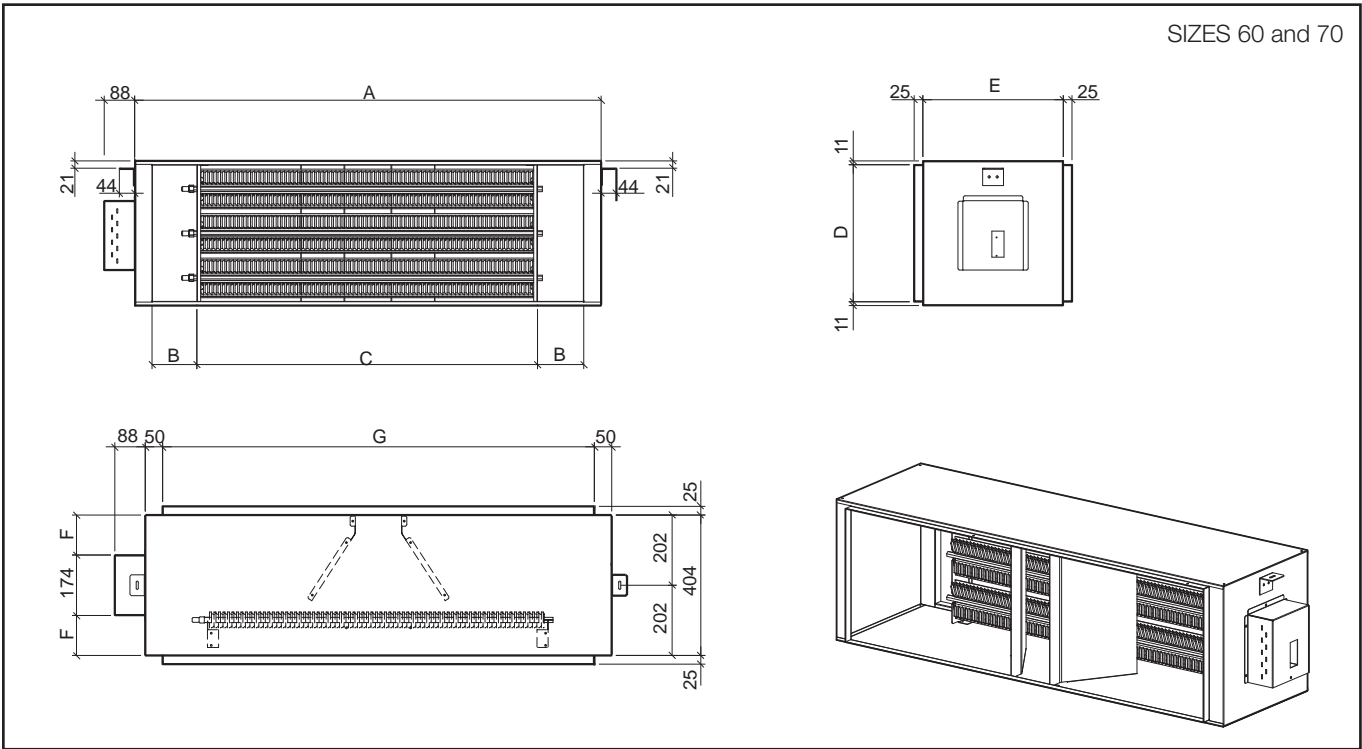
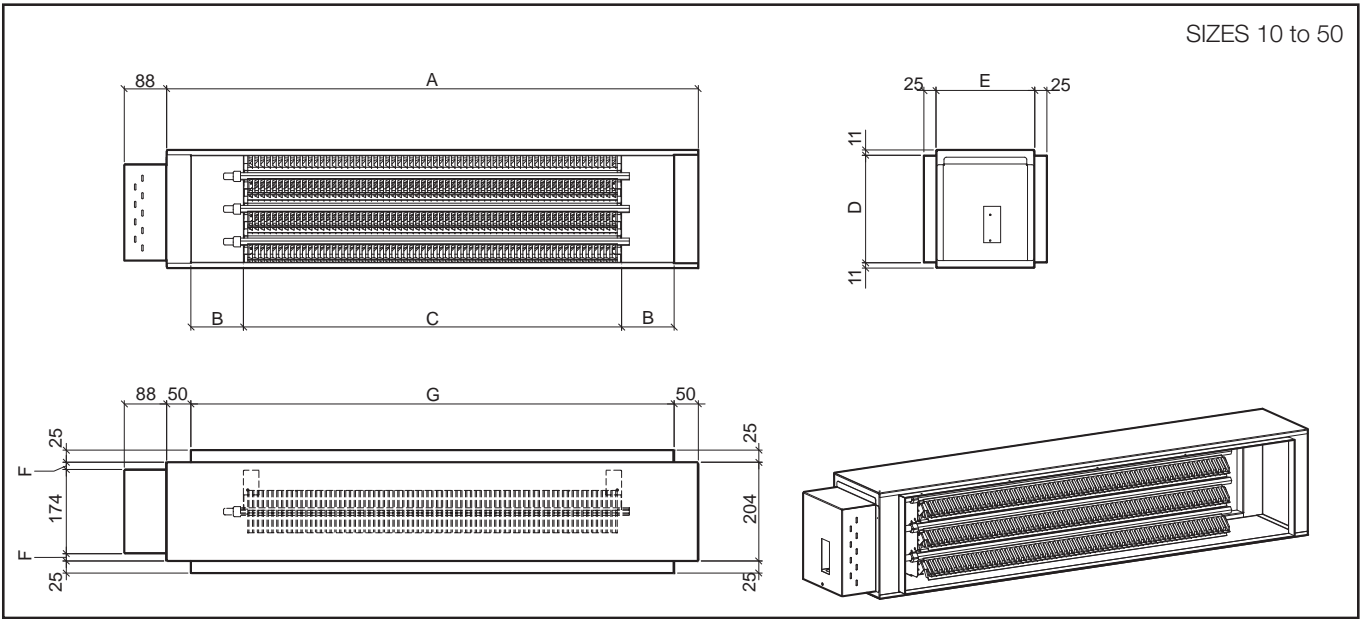

COMFAIR	HH	10	20	30	40	50	60	70
A	mm	648	998	1098	1338	1338	1342	2029
B	mm	84	159	109	128	128	131	*
C	mm	380	580	780	980	980	980	1929
D	mm	197	197	222	222	272	394	394
E	mm	204	204	204	204	204	404	404
F	mm	15	15	15	15	15	115	115
G	mm	548	898	998	1238	1238	1242	1929

RAM (90° PLENUM: SUPPLY)

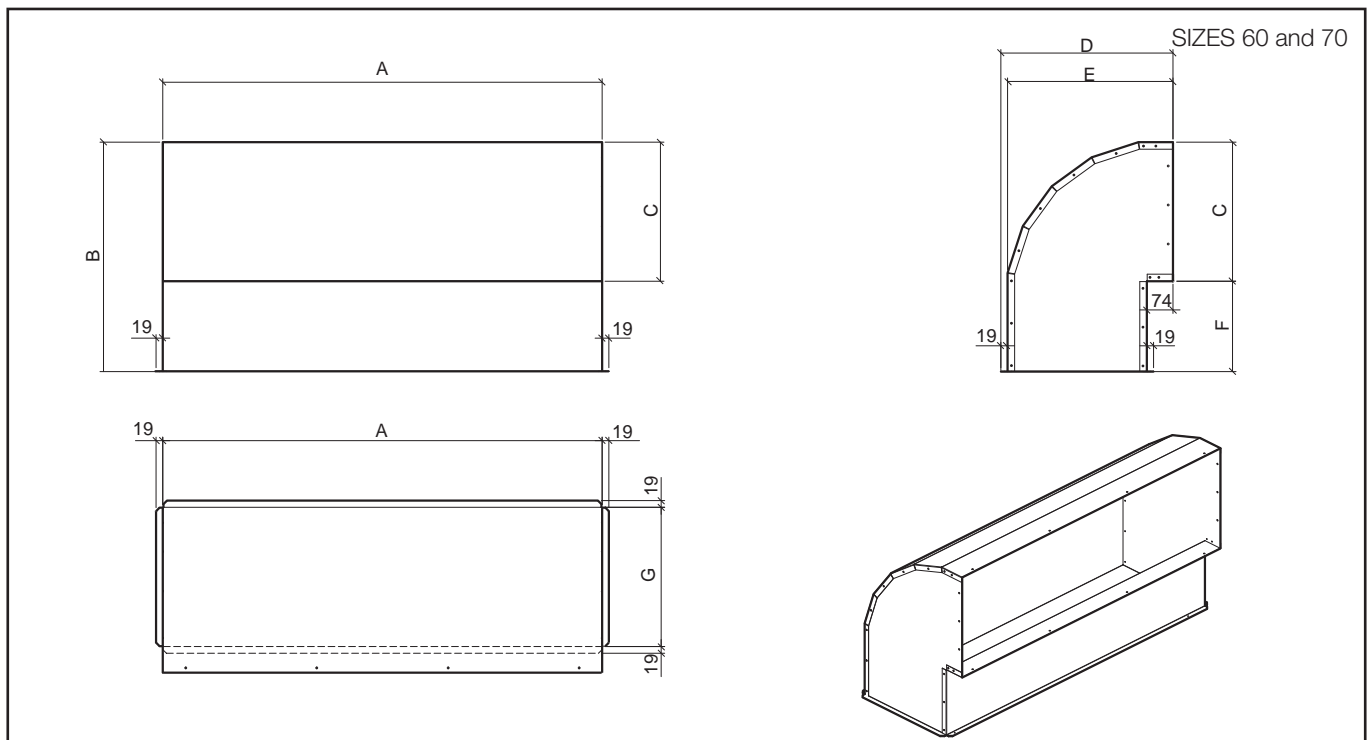
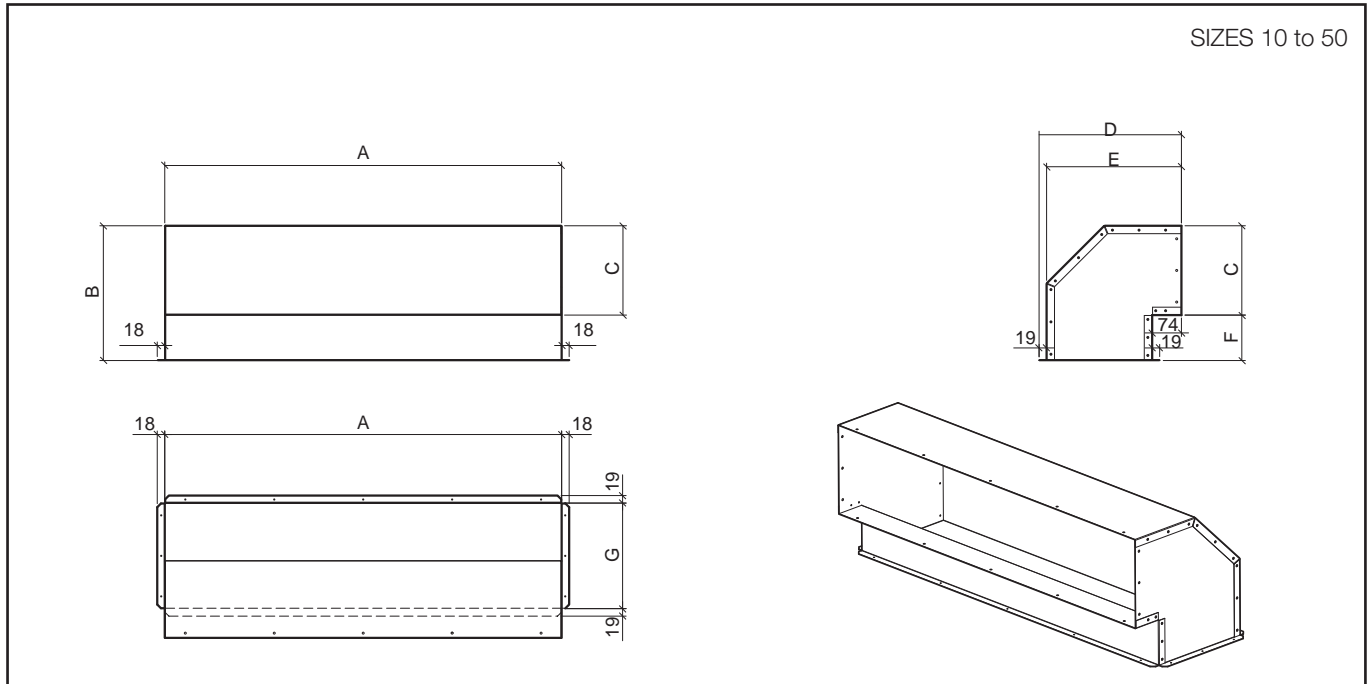

COMFAIR	HH	10	20	30	40	50	60	70
A	mm	552	902	1002	1242	1242	1242	1932
B	mm	315	315	340	340	390	650	650
C	mm	200	200	225	225	275	395	395
D	mm	360	360	360	360	360	490	670
E	mm	340	340	340	340	340	470	650
F	mm	115	115	115	115	115	255	255
G	mm	265	265	265	265	265	395	575

RAM (90° PLENUM: INTAKE)

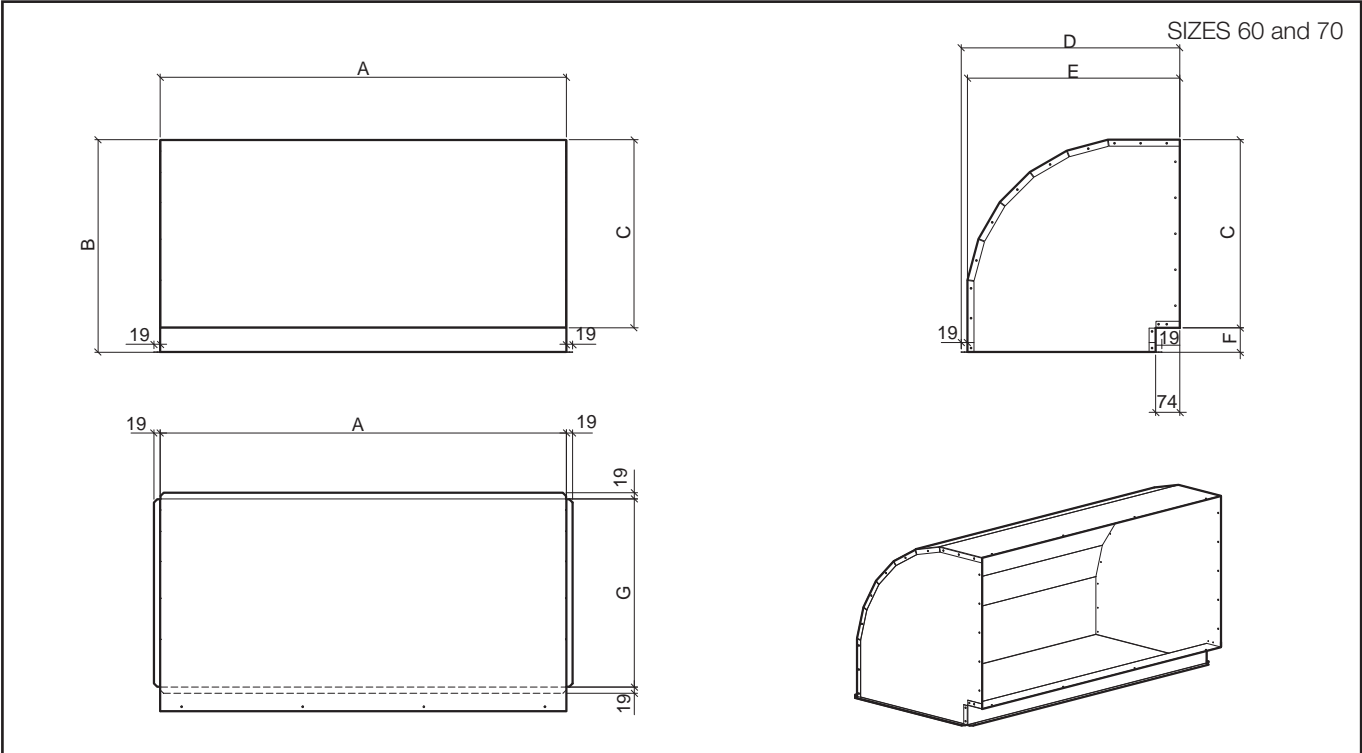
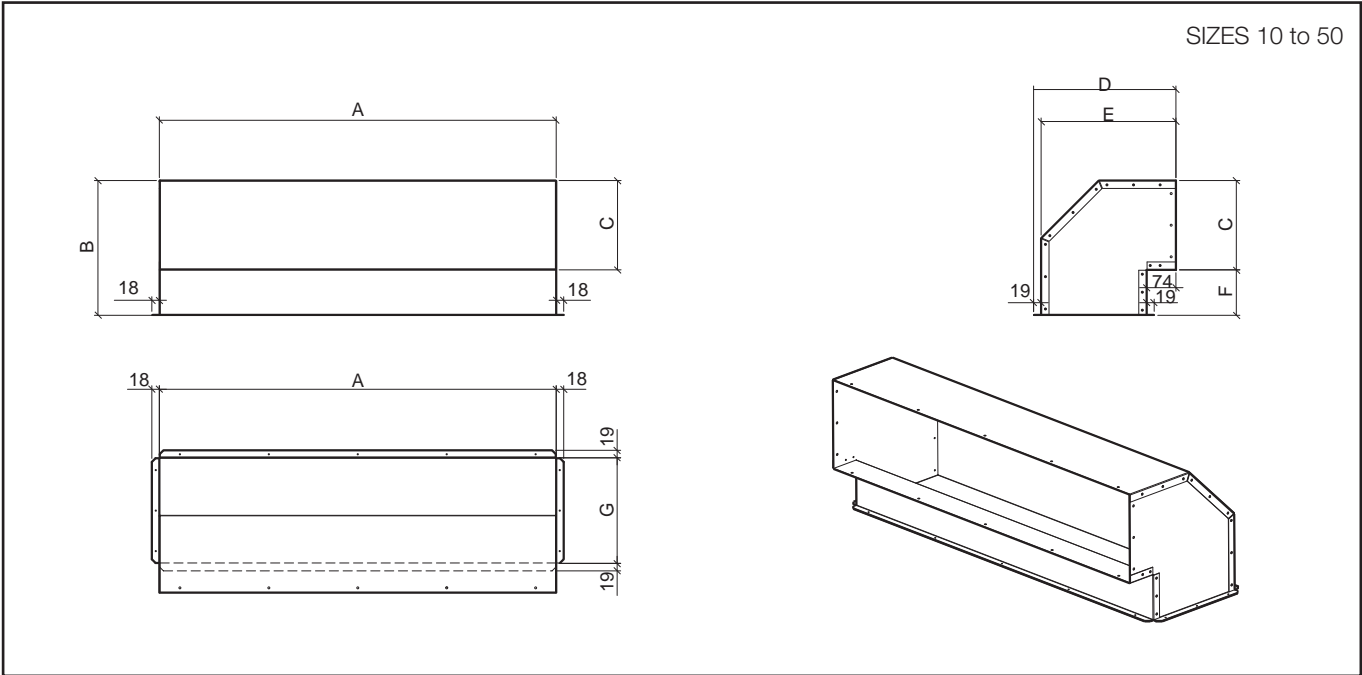

COMFAIR	HH	10	20	30	40	50	60	70
A	mm	552	902	1002	1242	1242	1245	1932
B	mm	315	315	340	340	390	650	650
C	mm	200	200	225	225	275	575	575
D	mm	360	360	360	360	360	670	670
E	mm	340	340	340	340	340	650	650
F	mm	115	115	115	115	115	75	75
G	mm	265	265	265	265	265	575	575

BAM (STRAIGHT: SUPPLY)

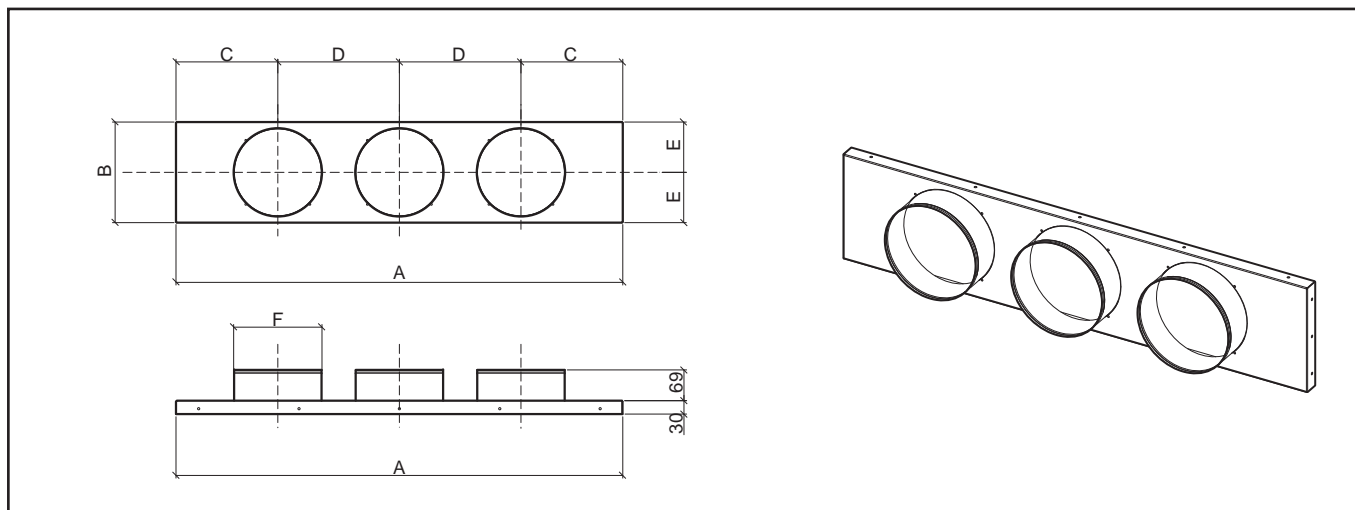

COMFAIR	HH	10	20	30	40	50	60	70
A	mm	550	900	1000	1240	1245	1245	1935
B	mm	200	200	226	226	276	416	416
C	mm	135	181	227	170	135	322,5	244,5
D	mm	280	270	272	300	325	600	482
E	mm	100	100	113	113	138	208	208
F	mm	2xØ200	3xØ200	3xØ200	4xØ200	4xØ200	2xØ400	4xØ400

BAM (STRAIGHT: INTAKE)

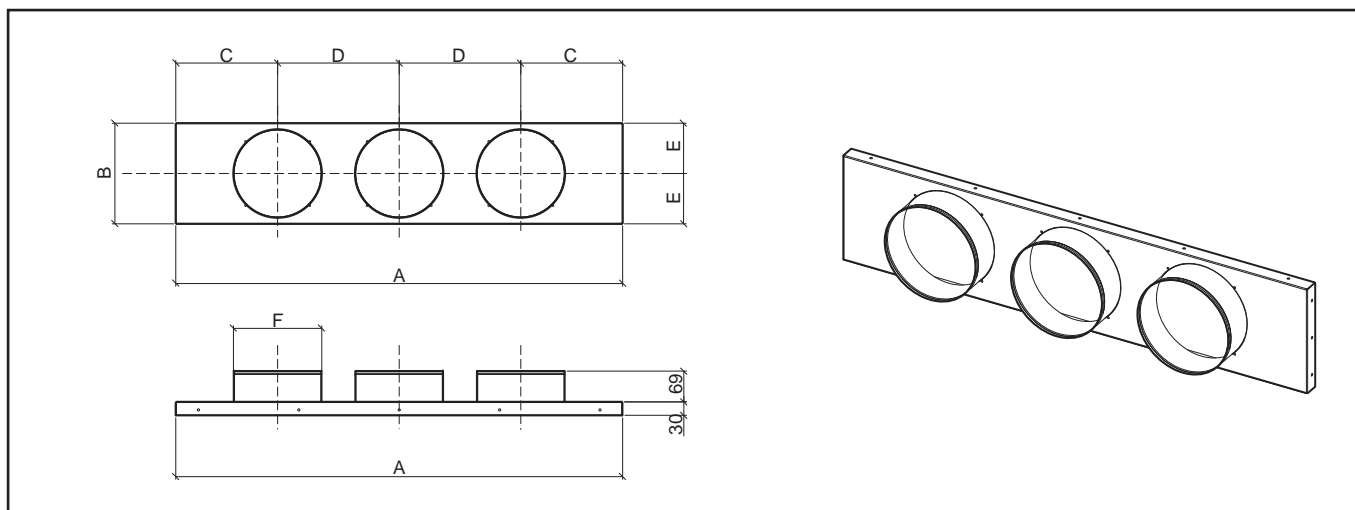

COMFAIR	HH	10	20	30	40	50	60	70
A	mm	550	900	1000	1240	1245	1245	1935
B	mm	200	200	226	226	276	576	576
C	mm	135	181	227	170	135	320	242
D	mm	280	270	272	300	325	600	482
E	mm	100	100	113	113	138	288	288
F	mm	2xØ200	3xØ200	3xØ200	4xØ200	4xØ200	2xØ400	4xØ400

FAM (CONNECTION FLANGE)

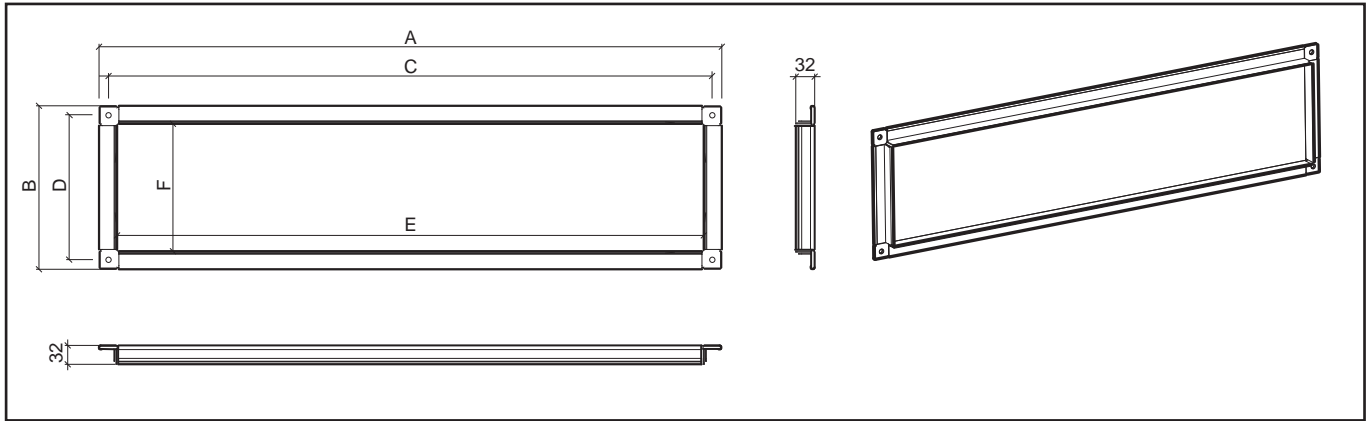

INTAKE

SUPPLY

COMFAIR	HH	10	20	30	40	50	60	70
A	mm	600	952	1052	1292	1292	1290	1985
B	mm	249	249	276	276	326	625	625
C	mm	570	922	1022	1262	1262	1260	1260
D	mm	219	219	246	246	296	595	595
E	mm	539	891	991	1231	1231	1230	1926
F	mm	188	188	215	215	265	565	565

COMFAIR	HH	10	20	30	40	50	60	70
A	mm	600	952	1052	1292	1292	1290	1985
B	mm	249	249	276	276	326	445	445
C	mm	570	922	1022	1262	1262	1260	1260
D	mm	219	219	246	246	296	415	415
E	mm	539	891	991	1231	1231	1230	1926
F	mm	188	188	215	215	265	385	385

GAM (ANTI-VIBRATING JOING)

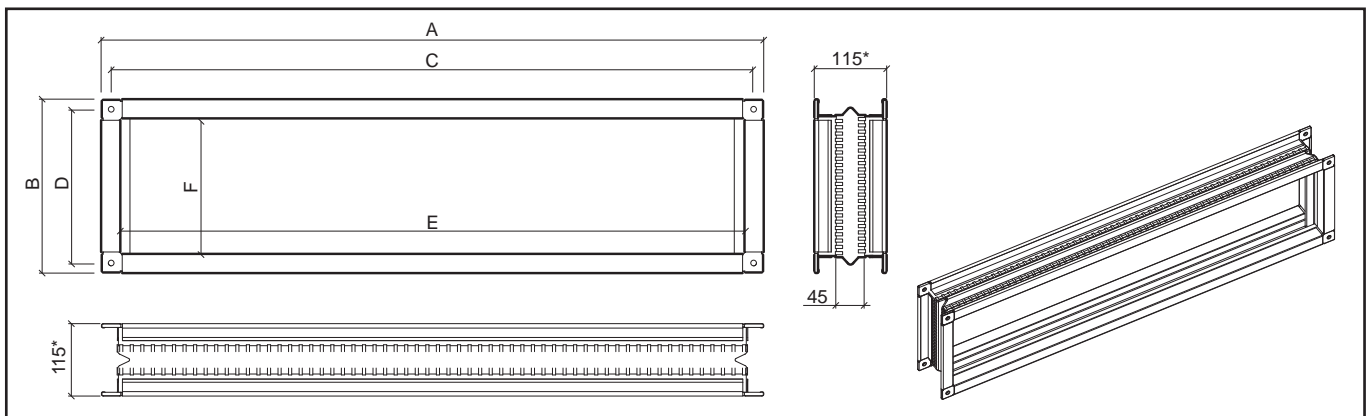

INTAKE

SUPPLY

COMFAIR	HH	10	20	30	40	50	60	70
A	mm	600	952	1052	1292	1292	1290	1985
B	mm	249	249	276	276	326	625	625
C	mm	570	922	1022	1262	1262	1260	1260
D	mm	219	219	246	246	296	595	595
E	mm	539	891	991	1231	1231	1230	1926
F	mm	188	188	215	215	265	565	565

COMFAIR	HH	10	20	30	40	50	60	70
A	mm	600	952	1052	1292	1292	1290	1985
B	mm	249	249	276	276	326	445	445
C	mm	570	922	1022	1262	1262	1260	1260
D	mm	219	219	246	246	296	415	415
E	mm	539	891	991	1231	1231	1230	1926
F	mm	188	188	215	215	265	385	385

EXAMPLE OF ACCESSORIES

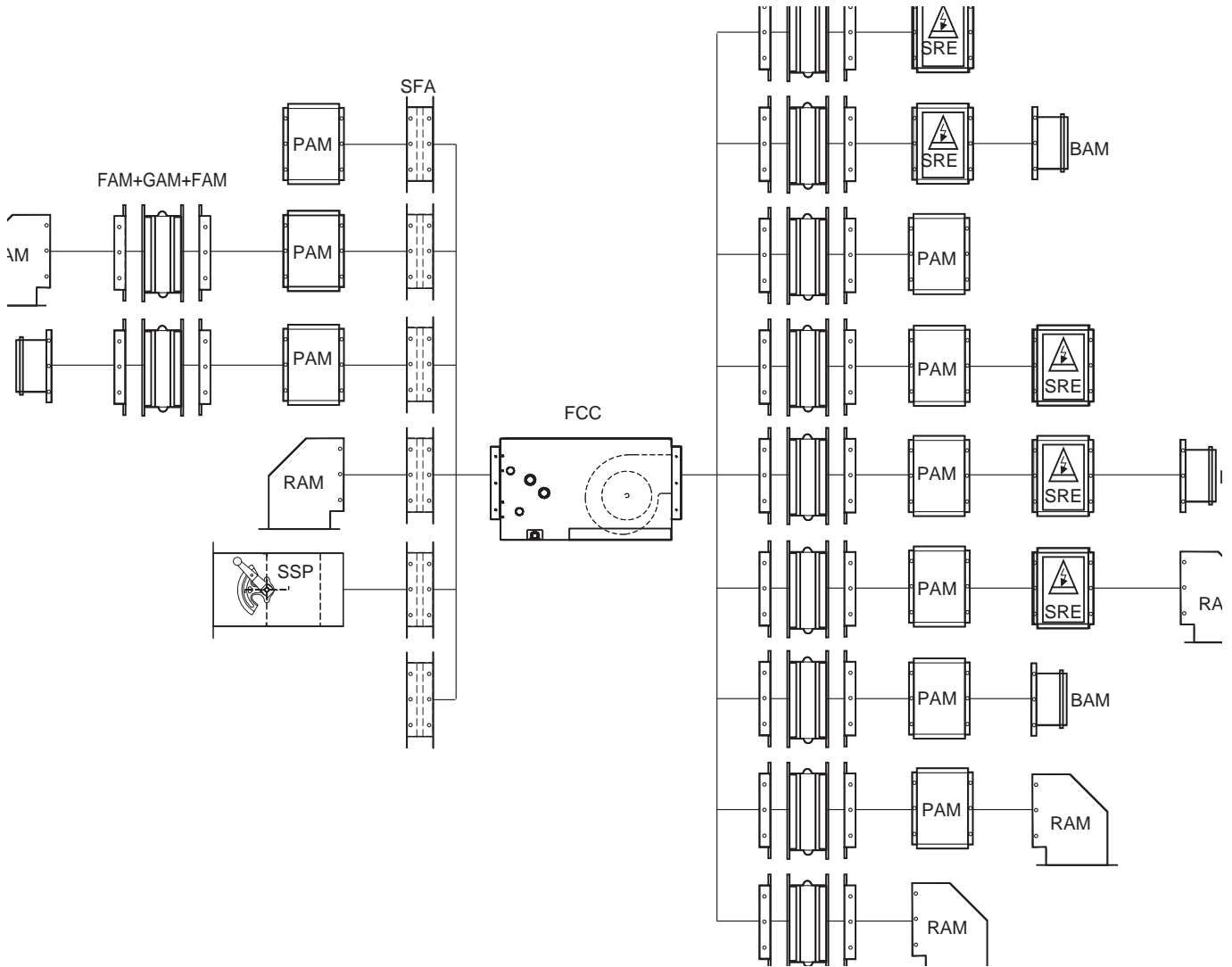

AUXILIARY DRAIN PAN

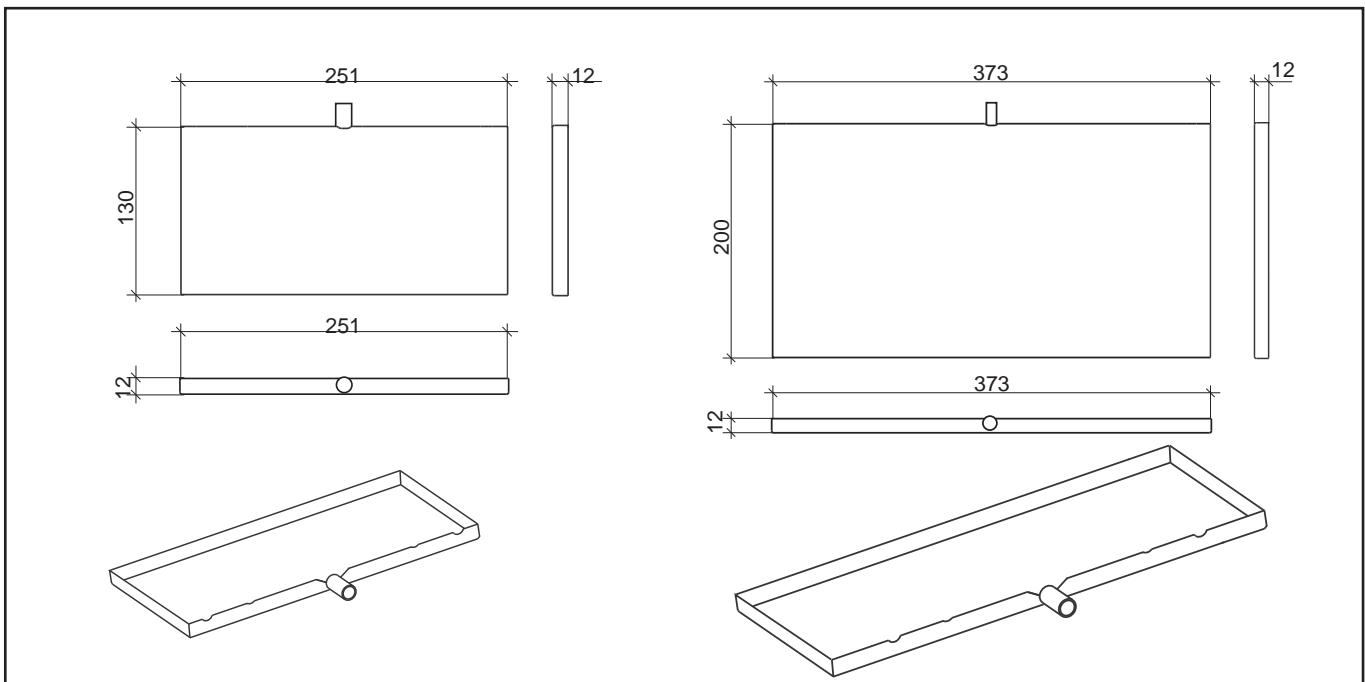

CONDENSATE DRAIN PUMP

HH 10 - 50

This pump is used to eliminate the condensation that collects in the tray in installations where there is no self-emptying outlet. The pump comes with filter to withhold impurities, float with activation contact, suction pipe, pump body complete with control electronics and overheating protection, wiring.

PUMP

Alarm contact normally closed that automatically cuts off the air conditioning system compressor or valve, thermal protection 90° on the pump coil, electrical connection by plug (delivered with 1 m cable), rubber mounting bracket included, ...

AVANTAGES

Small size, low noise level.

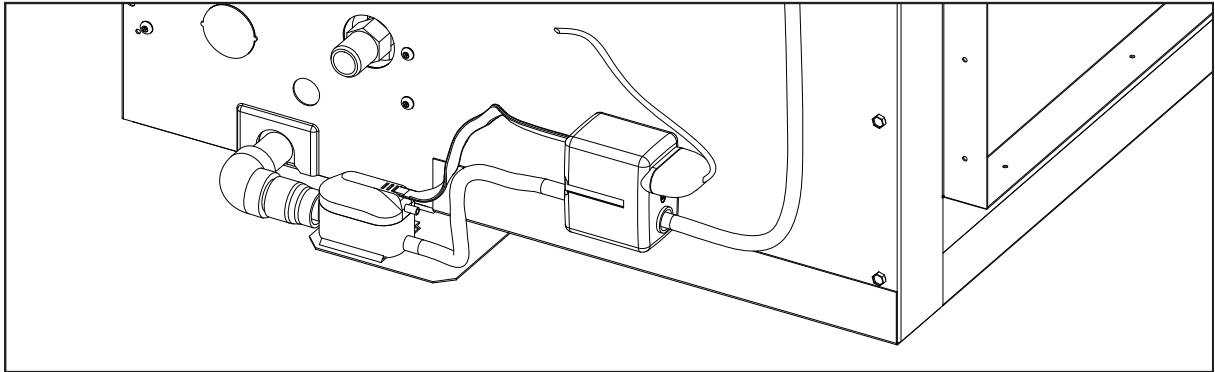

Main supply	V/Hz - W	230/50 - 18
Max. flow rate	l/h	20
Max. suction head	m	2
Max. discharge head	m	6
Alarm contact		NC 8 A resistive
Thermal protection (overheat)	°C	90
Sound level at 1 m	dB(A)	<34
Pump dimensions (Lxlxh)	mm	66 x 44 x 60
Detection unit dimensions (Lxlxh)	mm	55 x 38 x 32
Weight (including box)	kg	±0350

HH 60 - 70

This pump is used to eliminate the condensation that collects in the tray in installations where there is no self-emptying outlet.

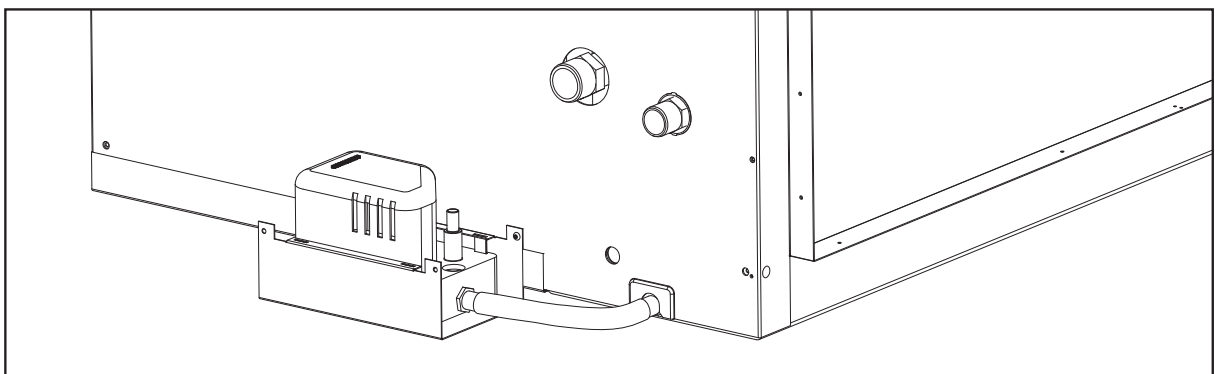

Main supply	V/Hz - A	230/50 - 10,8
Max. flow rate	l/h	150
Max. suction head	m	5,4
Alarm contact		NC 4 A resistive
Thermal protection (overheat)	°C	110
Sound level	dB(A)	<34
Pump dimensions	mm	195 x 130 x 122

GENERAL DESCRIPTION



CD2X6
 Wall mounted - 3 digits display
 On/Off - Heating/Cooling - 3 speeds
 Ambient temperature knob adjustment



RCE 10E
 Wall mounted
 On/Off - Heating/Cooling - 3 speeds
 Ambient temperature knob adjustment

	Wall mounted	
	CD2X6	RCE10E
Characteritics		
On/Off	◆	◆
Manual speed control	◆	◆
Automatic fan control	◆	◆
Manual Heating/Cooling control	◆	◆
Automatic Heating/Cooling control	◆	◆
Temperature setting knob	◆	◆
External centralised contact	◆	◆
Windows contact	◆	◆
Digital display	◆	
On/Off valve control	◆	◆
Modulating valve control	◆	◆
Available for		
2 pipes	◆	◆
2 pipes + electrical heater	◆	◆
4 pipes	◆	◆



lennoxemeia.com

SALES OFFICES :

BELGIUM AND LUXEMBOURG

☎ + 32 3 633 3045

FRANCE

☎ +33 1 64 76 23 23

GERMANY

☎ +49 (0) 40 589 6235 0

ITALY

☎ + 39 02 495 26 200

NETHERLANDS

☎ + 31 332 471 800

POLAND

☎ +48 22 58 48 610

PORTUGAL

☎ +351 229 066 050

RUSSIA

☎ +7 495 626 56 53

SPAIN

☎ +34 902 533 920

UKRAINE

☎ +38 044 585 59 10

UNITED KINGDOM AND IRELAND

☎ +44 1604 669 100

OTHER COUNTRIES :

LENNOX DISTRIBUTION

☎ +33 4 72 23 20 00



Due to Lennox's ongoing commitment to quality, the specifications, ratings and dimensions are subject to change without notice and without incurring liability. Improper installation, adjustment, alteration, service or maintenance can cause property damage or personal injury. Installation and service must be performed by a qualified installer and servicing agency