

APPLICATION GUIDE



COP up to
5,5*

HORIZONTAL PACKAGED AIR CONDITIONER

FLATAIR

ADVANCED
ULTRA HIGH EFFICIENCY & COMFORT

8 - 34 kW



Cooling capacity :
6 - 34 kW

Heating capacity :
6 - 29 kW

FLATAIR ADV-AGU-1801-E



www.lennoxemea.com

* Nominal heating conditions (EN14511) -
At partial load

LENNOX

FLATAIR

APPLICATION GUIDE

Ref : FLATAIR ADV AGU-1801-E

| | PAGE |
|-------------------------|------|
| General description | 3 |
| Options | 8 |
| General data | 11 |
| Refrigerant connections | 13 |
| Electrical connections | 14 |
| Dimensions | 17 |



Product designed and manufactured under quality management systems certified ISO 9001 and ISO 14001.



Our company's products comply with European standards.

All the technical and technological information contained in this manual, including any drawing and technical descriptions provided by us, remain the property of Lennox and must not be utilised (except in operation of this product), reproduced, issued to or made available to third parties without the prior written agreement of Lennox.

EXAMPLE : FAM H 020 S M 1 M

| | | |
|-----|--------------------------------|---|
| FA | FLATAIR ADVANCED | |
| M | M | Packaged unit |
| | S | Condensing unit (Outdoor unit) (Split version) |
| | I | Air treatment unit (Indoor unit) (Split version) |
| H | Heat pump unit | |
| 020 | Maximum cooling capacity in kW | |
| S | S | 1 circuit |
| | D | 2 circuits |
| M | R410A | |
| 1 | Revision number | |
| M | M | 400V/3/50Hz |
| | T | 230V/1/50Hz |

FAMH

The **FLATAIR ADVANCED** is an horizontal air conditioning unit.

It has been designed to perfectly match to small shopping centers and housing applications. It can be supplied either compact or in split system to be adapted to every builds configurations. Due to its compactness, it is designed for false ceiling and can be connected to air conducts both indoor and outdoor sections.

A wide range of options is available, all factory-assembled or supplied loose.

FLATAIR ADVANCED is only available in heat pump version.

From 8 to 35 kW

Two box sizes : A & B boxes.



SUSTAINABLE ENERGY DEVELOPMENT CHALLENGES

Faced with challenges relating to competitiveness and climate change, Europe has launched several initiatives for an intelligent energy strategy.

New regulations reflect the European Union's commitments on climate change and its determination to reach 20% efficiency improvement in buildings by 2020.

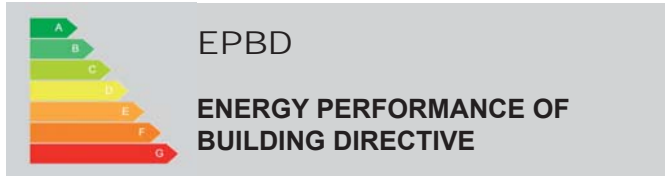

One of the major requirements of the new EPBD is to set Energy Certificates for buildings which grade the energy efficiency based on the building annual energy consumption. Soon companies will have to display their energy certificates to the public.

Another major new regulation linked to energy savings is Ecodesign directive. This directive requires minimum seasonal efficiencies in heating and cooling modes and is applicable since the 1st of January, 2018.

To offer optimized comfort to the end users and to enable a maximum of energy efficiency, our units are not only designed at full load but also part loads.

Whatever the outdoor and indoor temperatures, the unit can offer the best in terms of energy efficiency and comfort.



THE EXPERIENCE & COMMITMENT OF THE EUROPEAN LEADER TO DRIVE CONTINUOUS ENERGY SAVINGS

Lennox contribution to combat rising energy costs and global warming is to design innovative, efficient and dependable products, while providing best comfort and air quality.

As a major player on the European HVAC market, Lennox is a reference in sustainable development and has been assembling its products in ISO-14001 certified factories since 2007.



FLATAIR ADVANCED: COMFORT AND ENERGY CONSUMPTION OPTIMIZED

LOW ENERGY CONSUMPTION



Thanks to:

- eDrive direct transmission variable speed ventilation system,
- Advanced refrigeration components with R410 inverter compressor, electronic expansion valves, extended heat exchange surface area, alternate and dynamic defrost cycles,
- Fresh air and free cooling management,
- Optimized operation with eCLIMATIC

FLATAIR Advanced range will offer you **the best in terms of energy saving.**

COMFORT

Thanks to:

- eDrive direct transmission variable speed ventilation system,
- Advanced refrigeration components with R410 inverter compressor, electronic expansion valves,
- Fresh air and free cooling management,
- Optimized operation with eCLIMATIC

FLATAIR Advanced range will offer you **the best in terms of acoustic and thermal comfort.**

RECYCLING MANAGEMENT



- Unit assembled in an ISO14001 certified facility.
- Refrigerant R410A to reduce refrigerant charge.
- Use of refrigerant without any ozone depleting effect.
- Reduced material usage with compact packaged design.

ENERGY EFFICIENCY THANKS TO INVERTER COMPRESSOR

The compressor speed continuously fits to cooling (or heating) demand, offering the best seasonal efficiency

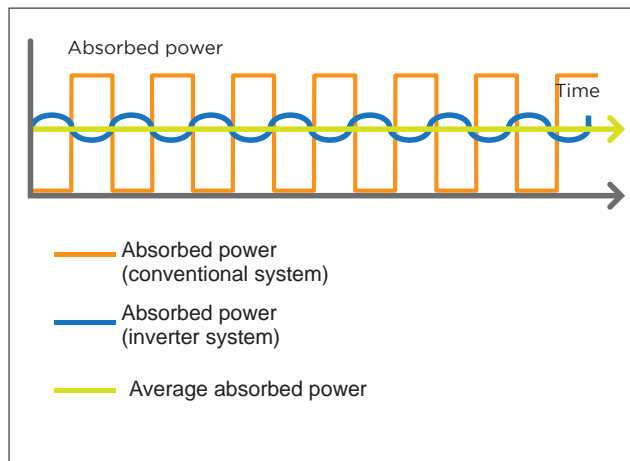
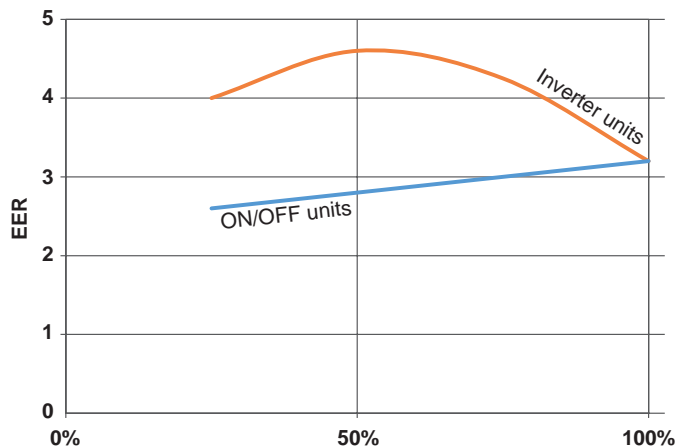

ADDITIONAL CONSUMPTION REDUCTION WITH EDRIVE

eDRIVE is Lennox' answer for high efficiency ventilation with direct transmission, variable speed drives to save energy and reduce maintenance cost



ADVANCED REFRIGERATION CIRCUIT

FLATAIR ADVANCED refrigeration circuit is fitted with variable speed compressor, variable speed fans and electronic expansion valve. These 4 components enable to adjust precisely the production to the thermal needs. The energy produced is just what you need.

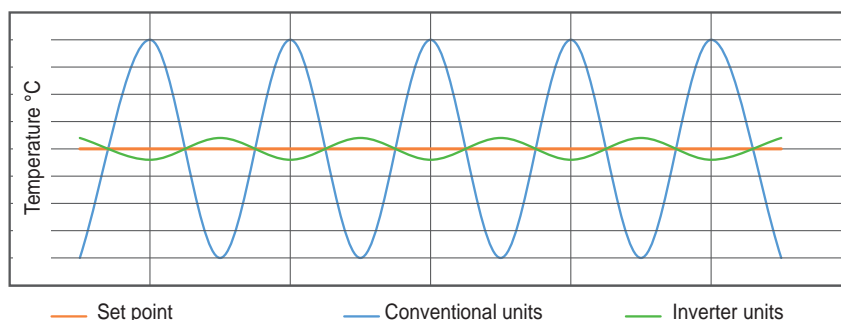

FREE COOLING

As an option, **FLATAIR ADVANCED** may be fitted with an economizer. Thanks to this option, it is possible to cool (or to heat) with compressor operation when outdoor temperature enables it. Thermodynamic cooling can be replaced by FREE COOLING when outdoor temperature is below the building set point, thus saving up to 15% on annual energy consumption.

NEW eCLIMATIC CONTROL

Our **FLATAIR ADVANCED** range includes our new generation of eCLIMATIC control.

Main technical features :

- Plastic cover to protect the circuit board from water entry and humidity,
- Two independent buses, one for display and sensors connection and another one for internal components,
- Possibility of storing all parameterized conditions before an alarm is produced.

eCLIMATIC is designed to provide the best energy efficiency throughout unit's lifecycle while ensuring reliable and consistent operation with user friendly interfaces.

eCLIMATIC monitors more parameters than ever to improve operation and maximize energy efficiency and reliability of the unit.

eCLIMATIC offers three different platforms of display:

- End customer display (DC): with basic configurations, set points, main temperature readings and alarms.
- Multiple display (DM): graphic customer display with basic configuration of the end customer display plus schedule programming and set of fresh air %.
- Service display (DS): Specially focused to maintenance experts and installers, with full access to every parameter and configuration.

eCLIMATIC provides the following functions as standard :

• Refrigeration circuit efficiency management

The new PI algorithm of the eCLIMATIC controls the supply air temperature and a temperature difference between supply and return. It is able to optimize the refrigeration circuit operation to perfectly match the required cooling or heating load, maximizing thus efficiency and comfort thanks to variable speed compressor and electronic expansion valves.

It will also improve reliability with features such as compressor operating limits monitoring, (High and Low refrigerant pressure and temperature now measured and displayed on DS service display and Bus) refrigerant leak detection or compressor operating time equalization and protection against excessive short cycling.

• Dynamic defrost:

It is a standard feature of all Lennox heat pumps. It limits the number and the duration of the defrost cycles in winter to maximize COP.

• Intelligent fresh air management:

With accurate percentage of fresh air, the dampers are regularly calibrated to introduce just the required amount of fresh air in the building to reduce annual energy consumption. The fresh air ratio can also be controlled using the indoor CO₂ level as an input.

• Intelligent heating priority optimization:

This unique feature on the market, allows the user to program the priority between the different heating elements (thermodynamic, electric heaters). This is particularly interesting on units equipped with electrical heater. This feature maximizes energy efficiency by optimizing heat pump operation depending on the outdoor temperature.

• Morning anticipation and dynamic set point

It can be programmed to switch-on in the morning to reach the occupied zone temperature set point just in time. The unit will start heating the building at a different time in the morning depending on the outdoor temperature: The lower the outdoor temperature is, the earlier the unit would start to ensure that the set point is reached by the time the first occupied zone (Z1) is starting. This avoids early start when outdoor temperature is mild.

Example for a unit programmed to anticipate morning switch-on if outdoor temperature is below 10°C at a rate of 10 minutes/°C. Dynamic set point can be used in summer to offset the ambient temperature set point according to the outdoor temperature. This is to avoid large temperature difference between indoor and outdoor. The indoor temperature set point would then increase with the outdoor temperature improving comfort and saving large amount of energy.

Dynamic set point can be used in summer to offset the ambient temperature set point according to the outdoor temperature. This is to avoid large temperature difference between indoor and outdoor. The indoor temperature set point would then increase with the outdoor temperature improving comfort and saving large amount of energy.

• Faults and alarms

eCLIMATIC manages more than 90 different faults and alarms codes and can store the last 32 with time and date. The stored faults and alarms can then displayed on the DS Service display and on the communication bus with the full text detail.



• **Scheduling**

In order to ensure the unit perfectly matches the requirements

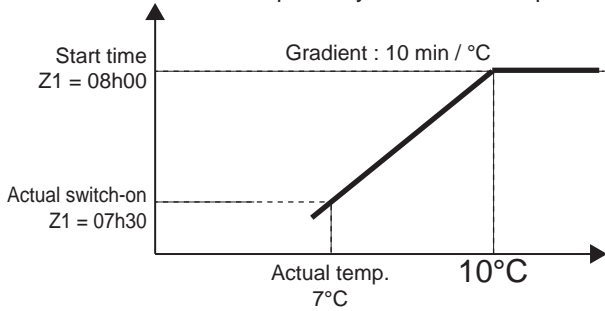

of the most difficult applications in terms of occupation and varying internal loads, the new eCLIMATIC offers now up to 7 time zones per day (Z0 to Z6) adjustable by steps of 10 minutes. Each time zone can be programmed to follow one of four possible operating modes:

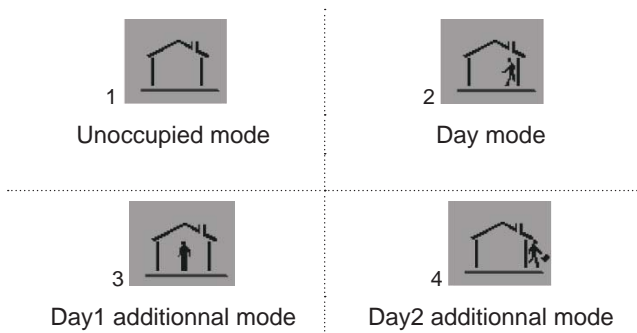

CONSTRUCTION, INSTALLATION AND SERVICE

FLATAIRADVANCED is assembled with the highest standards of quality and is compliant to ECODESIGN directive.

FLATAIR ADVANCED units comply with PED 97-23 and EN 60204 standard. All our units are manufactured in ISO 9001 and 14001 factories.

PLUG AND PLAY SYSTEM

All options are factory installed in the unit, meaning that they are ready for use, optimizing the time spent on site for the installation. To make installation easier, **FLATAIRADVANCED** units power supply does not require neutral connection. All the electrical elements are factory tested and follow the highest quality standards.

• **Circuit breakers**

To improve safety and extend life time, circuit breakers protect against over-loading, over current and a disconnected supply phase. Maintenance is also improved as there is no requirement to change fuses. The electrical panel is manufactured in accordance with EN60204 electrical directive.

• **Main disconnect switch**

The main switch is used as an emergency cut off. Main disconnect switch is lockable to increase safety around the unit. Switching off the unit with the disconnect switch will reset all.

INDOOR AIR QUALITY

FLATAIR ADVANCED has all the elements necessary to ensure the highest standards of indoor air quality:

• **Filters**

To ensure the best quality of indoor air, the "high filtration quality" option is available. The additional box is made up of a "M5 + F7" filter and has to be mounted directly in the supply air duct.

• **Fireproof insulation**

FLATAIRADVANCED air treatment section is provided with A2 s1 d0 (M0) improving the safety of the unit against fire.

• **EC fans ventilation system**

FLATAIR ADVANCED is fitted with EC fans as standard. Compared with traditional pulley and belts system, this technology ensures that no belt particles can be carried away into building. This ventilation system is compliant with EN13977 air quality norm.

• **Analog filter detection**

As an option, the unit can be fitted with air differential pressure sensors that measure the pressure drop across the evaporator coil and filters.

If this pressure drop is above 50 Pa, the unit is considered to be operating.

If the pressure drop is below, there should be a problem of ventilation.

When values are over 250 Pa (default value from factory), a signal is sent to the terminal to indicate filters must be changed, and after one week, unit stops. This value can be adjusted during the commissioning.

AUXILIARY HEATING OPTIONS

Electrical heater

Made of welded blinded elements, all electrical heaters in **FLATAIR ADVANCED** are provided with two safety switches to prevent overloading.

Heaters are available in three different sizes:

- Standard capacity
- Medium capacity with a one-stage regulation
- High modulating capacity

Electrical heater capacities

| Units | 020 & 035 |
|---------------------------------------|-----------|
| Electrical heater - Standard capacity | 4.5 kW |
| Electrical heater - Medium capacity | 9 kW |
| Electrical heater - High capacity | 15 kW |

FILTRATION OPTIONS

FLATAIR ADVANCED offers different levels of filtration, allowing to meet any application and any level of filtration required by the installation.

As standard, the unit are delivered with G4 filters.

As an option, M5+F7 filter is available.

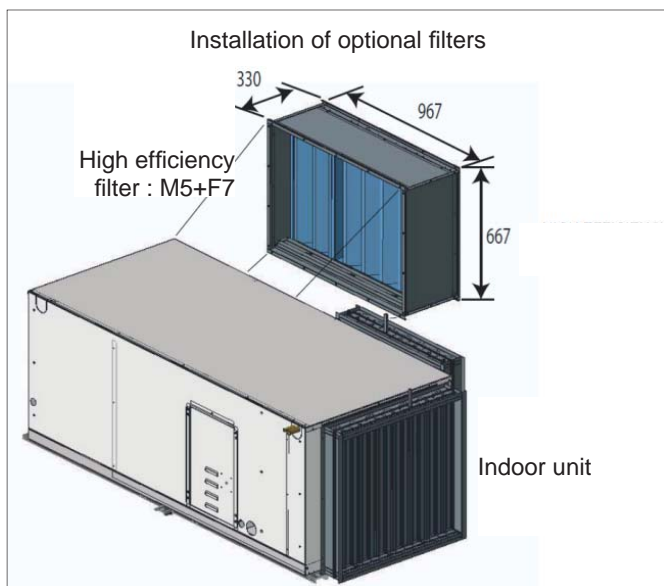

THREE PHASES CONTROL

This phase control device offers the guarantee of the correct phase connection, together with an overvoltage and under voltage protection.



CONTROL OPTIONS

Control terminals

FLATAIR ADVANCED offers 3 different platforms of control, depending on the level of accessibility and the competences required.

DC Comfort Display



This is a remote controller for non-technical customer. It is designed to fit aesthetically inside a room and be very easy to use. It has a 24V supply to be connected to the unit and can be installed at maximum 30 meters away from the unit.

The graphical display gives information such as running mode of the unit, status of the fan, set point, % of fresh air, outside air temperature. Customer can set the temperature set point for a given time zone, switch the unit "ON" or "OFF" and adjust the clock. DC can display fault codes with a reset possibility, ambient, supply and outdoor temperature, fresh air damper position (%), time zone and operating mode pictogram, heating or cooling status. It is also able to display supply fan airflow rate (0-33-66-100%) and component status for compressors, defrost, condenser fans and auxiliary heaters.

DC comfort display is equipped with a temperature sensor that can be used as room temperature sensor.

DM Multi-units Display



This display gives access to more functionality than the DC and allows managing up to 8 units on a single Bus-wire. Customer will be able to change the operating time zone and mode. The units can be connected to operate on a Master/Slave principle. Installation up to 1000 m from the unit.

DS Service Display



This plug and play service display and controller allows service personal to set up to read and modify all unit parameters (Unit settings, operating time and number of compressor starts, low and high pressure reading, airflow rate of supply fan, and read the history of last 32 faults...).

This controller has been designed to be very user friendly, with 6 different keys and graphic display. It includes scrolling menus and full text (no codes) explanation. It is available in English or another language.

Dry Contact board

This board has been developed for any customer who wants to take over the control of the unit using Digital or analogue input signal. With this dry contact board option the customer can set:

- 4 digital inputs (On/Off, clear faults, various component unloading, heating priority modifications, thermostat orders...)
- 4 digital Outputs (alarms reporting, components status, scheduling time zone and operating mode status, cooling, heating, defrost and auxiliary heating status...)
- Up to 4 analogue inputs (external temperature humidity probes, fresh air input signal, force fan speed and temperature set point offset).
- 1 analogue output (Humidifier)

Note that eCLIMATIC controller always stays in charge of all safety algorithms, defrost operation and free cooling. This option is required to control the unit with a "universal thermostat".

COMMUNICATION OPTIONS

Modbus interface / Modbus TCP IP

The eCLIMATIC ModBus interface is required to connect the unit to a BMS using «ModBus protocol». No other hardware than this board is required to have ModBus communication. One board required per unit. The ModBus interface is available in two versions to be connected with RS485 or TCP/IP.

This board is also mandatory for any connection between the unit and a Lennox ADALINK system.

LonWorks® interface

This board is a LonWorks® interface, needed for any BMS with "Lon protocol" and RS485 connection to communicate with the unit. No other hardware than this board is required to have LonWorks® dialog. One board required per unit. Variable list is available in the control IOM.

BACnet® interface

The eCLIMATIC BACnet® interface is required to connect the unit to a BMS using BACnet® protocol. No other hardware than this board is required to have BACnet® communication. One board required per unit. The BACnet® interface is available in two versions to be connected with RS485 or TCP/IP depending on site requirements.

FRESH AIR OPTIONS

Indoor air quality sensor

Indoor air quality is controlled from the eCLIMATIC main controller. A VOC (Volatile Organic Component) sensor detects the amount of CO2 in the ambient air between 0 and 2000PPM. (This obviously varies depending upon space occupancy levels). The VOC sensor sends a proportional signal (0-20mA) to the eCLIMATIC controller which then modulate the fresh air.

AIRFLOW CONFIGURATIONS

Unit delivered as standard with airflow configuration nr 0. Removing panels allows to obtain different air flow configuration (nr 1), to be adapted to any buildings.

FAMH 020 & 035

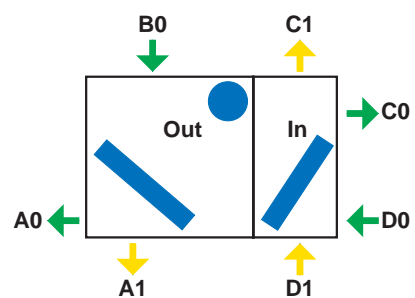

FAIH/FASH 020 & 035

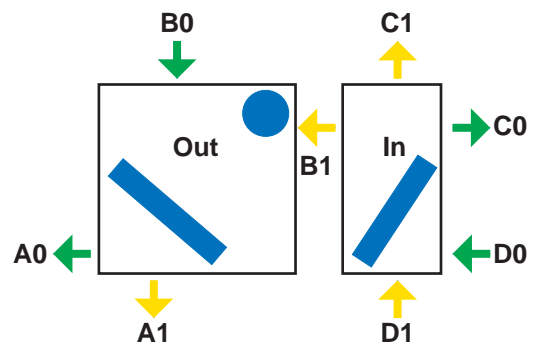

— Standard — Option

OTHER OPTIONS

Low noise option

In option, the unit is delivered with a compressor jacket enabling a reduction of around 2 dB(A).

Anticorrosion protection

When the units are installed in potential aggressive environment like coastal environment, FLATAIR ADVANCED offers the possibility of a protection treatment in all the coils (only condenser or both condenser and evaporator).

Nominal thermal performances

| FAMH | | 20 | 35 |
|---|----|------------|------------|
| Cooling capacity ⁽¹⁾ (Mini / Maxi) | kW | 6,1 / 22,4 | 9,7 / 33,4 |
| EER ⁽¹⁾ | | 2,91 | 2,79 |
| Heating capacity ⁽²⁾ (Mini / Maxi) | kW | 6,0 / 19,8 | 9,5 / 28,8 |
| COP ⁽²⁾ | | 3,15 | 3,16 |

(1) **Cooling mode :**
Outdoor temperature 35°C DB
Indoor temperature 27°C DB / 19°C WB

(2) **Heating mode :**
Outdoor temperature 7°C DB / 6°C WB
Indoor temperature 20°C DB

(1) & (2) According to **EN14511** nominal conditions
Cooling and heating modes

Seasonal efficiencies

| FAMH | | 20 | 35 |
|---|---|-------|-------|
| Seasonal Energy Efficiency Ratio SEER ⁽¹⁾ | | 4,05 | 4,35 |
| Seasonal energy efficiency η_{s,c} ⁽²⁾ | % | 159,0 | 170,9 |
| Seasonal Coefficient of Performance SCOP ⁽¹⁾ | | 3,06 | 3,10 |
| Seasonal energy efficiency η_{s,h} ⁽²⁾ | % | 119,4 | 120,9 |

(1) In accordance with standard EN14825, heating mode performance is given for average climate.

(2) Space cooling and space heating energy efficiency following Ecodesign regulation EU 2016/2281

Airflow data

| FAMH | | 20 | 35 |
|-----------------------------------|-------------------|------|-------|
| Air treatment unit | | | |
| Minimum airflow rate | m ³ /h | 1800 | 2800 |
| Maximum airflow rate | | 4500 | 6200 |
| Maximum available static pressure | Pa | 500 | |
| Condensing unit | | | |
| Minimum airflow rate | m ³ /h | 4300 | 6900 |
| Maximum airflow rate | | 7400 | 10200 |
| Maximum available static pressure | Pa | 300 | |

Acoustic data

| FAMH | | 20 | 35 |
|---|-------|----|----|
| Sound power level Outdoor unit | dB(A) | 74 | 85 |
| Sound power level Indoor unit ⁽¹⁾ | | 77 | 86 |

(1) Supply duct

Electrical data

! Values for standard units only

| FAMH | | 20 | 35 |
|-----------------------|----|---------|------|
| Voltage | V | 400/3Ph | |
| Frequency | Hz | 50 | |
| Maximum current | A | 18,7 | 26,9 |
| Starting current | | 20,4 | 33,3 |
| Short circuit current | kA | 10 | |

Refrigeration circuit

| FAMH | | 20 | 35 |
|--|----|---------|----|
| Number of circuits/Number of compressors | | 1/1 | |
| Capacity variation (inverter) | | 30-100% | |
| Refrigerant | | R410A | |
| Refrigerant load | kg | 6,6 | 8 |

Operating limits

| FAMH | | 20 | 35 | |
|---|-----|-----|----|--|
| Operating limits - Cooling mode | | | | |
| Outdoor coil : Maximum air inlet temperature | °C | 25 | | |
| Outdoor coil : Minimum air inlet temperature | | -12 | | |
| Indoor coil : Maximum air inlet temperature | | 32 | | |
| Indoor coil : Minimum air inlet temperature | | 21 | | |
| Operating limits - Heating mode | | | | |
| Outdoor coil : Maximum air inlet temperature | | °C | 48 | |
| Outdoor coil : Minimum air inlet temperature | -10 | | | |
| Indoor coil : Maximum air inlet temperature | 24 | | | |
| Indoor coil : Minimum air inlet temperature | 0 | | | |

SPLIT UNITS ONLY :

For split units, and in order to be adapted to every configuration, the long distance option allows to have a length up to 30 m between thermodynamic and air treatment units.

To design your installation, please refer to the following examples.

A,B,C: Different installations configurations

L: Total length

1: Gas line

2: Liquid line

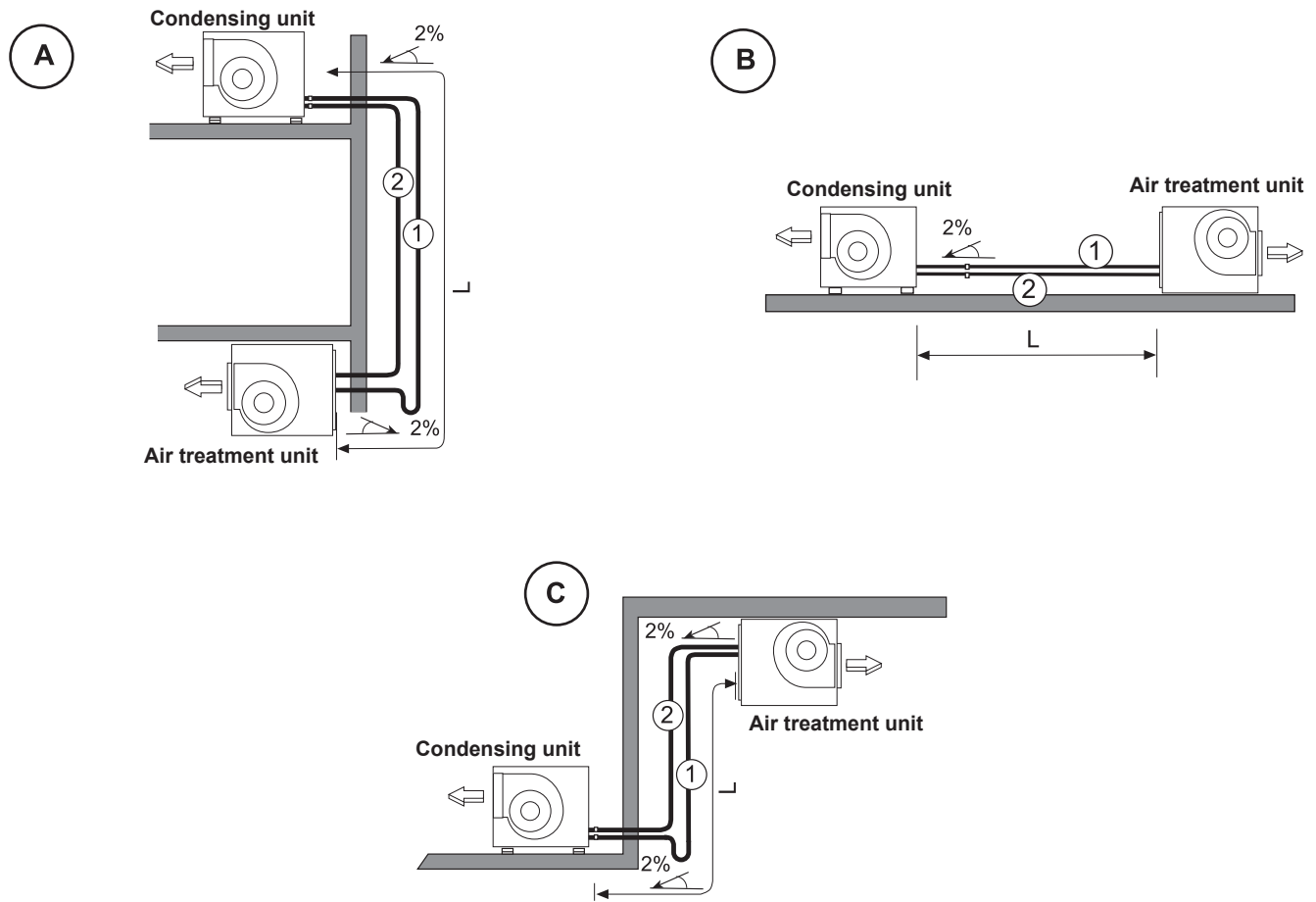

Refrigerant connections

| | | |
|--------------------|------|--------|
| FAMH | 20 | 35 |
| Liquid connections | 1/2" | 5/8" |
| Gas connections | 7/8" | 1 1/8" |

PACKAGED UNITS

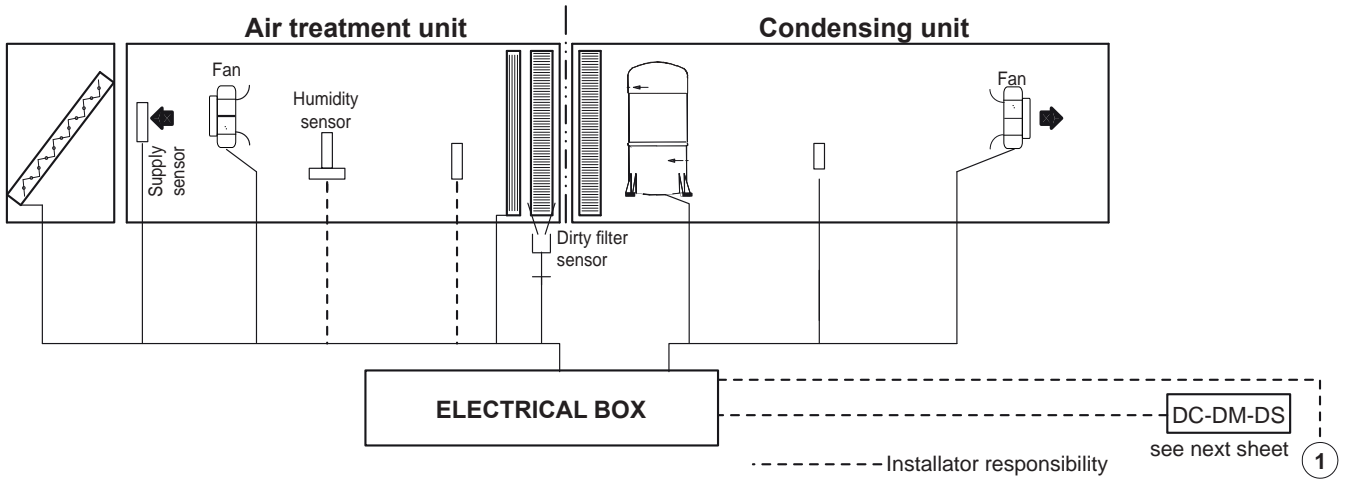

| | Connection 1 | | | |
|----------|-------------------------|--------------------|-------------------------|---------------------|
| | Basic unit | Basic unit + ELHS* | Basic unit + ELHM* | Basic unit + ELHHM* |
| FAMH 020 | 4G x 6 mm ² | | 4G x 10 mm ² | |
| FAMH 035 | 4G x 10 mm ² | | 4G x 16 mm ² | |

SPLIT UNITS

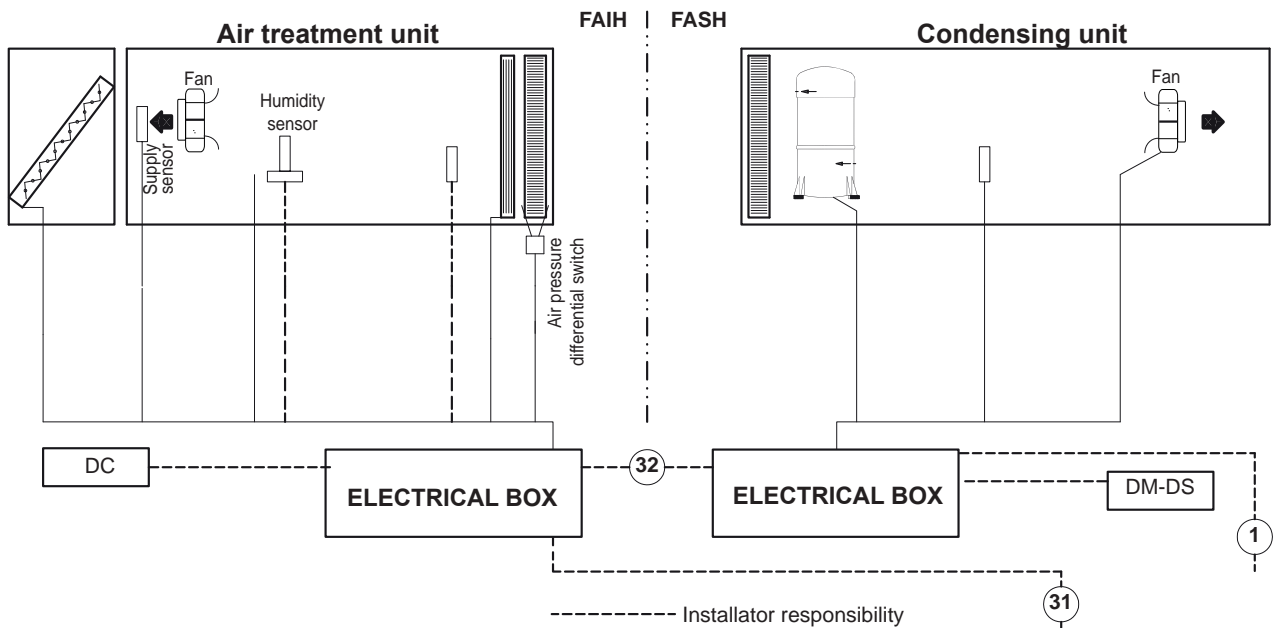

| | Connection 1 | Connection 31 | | | Connection 32 |
|---------------|------------------------|--------------------------|-------|------------------------|-------------------------------------|
| | Basic unit | Basic unit | ELHS* | ELHM* | ELHHM* |
| FAIH/FASH 020 | 4G x 4 mm ² | 4G x 2,5 mm ² | | 4G x 4 mm ² | 3 x 0,5 mm ² Shielded |
| FAIH/FASH 035 | 4G x 6 mm ² | | | | |

| | | | | | |
|--------------|--|--------------|--------------------------------------|---------------|---|
| *ELHS | Electrical heater Standard capacity | *ELHM | Electrical heater Medium capacity | *ELHHM | Electrical heater High modulating capacity |
|--------------|--|--------------|--------------------------------------|---------------|---|

TERMINAL CONNECTION WITH PACKAGED UNIT

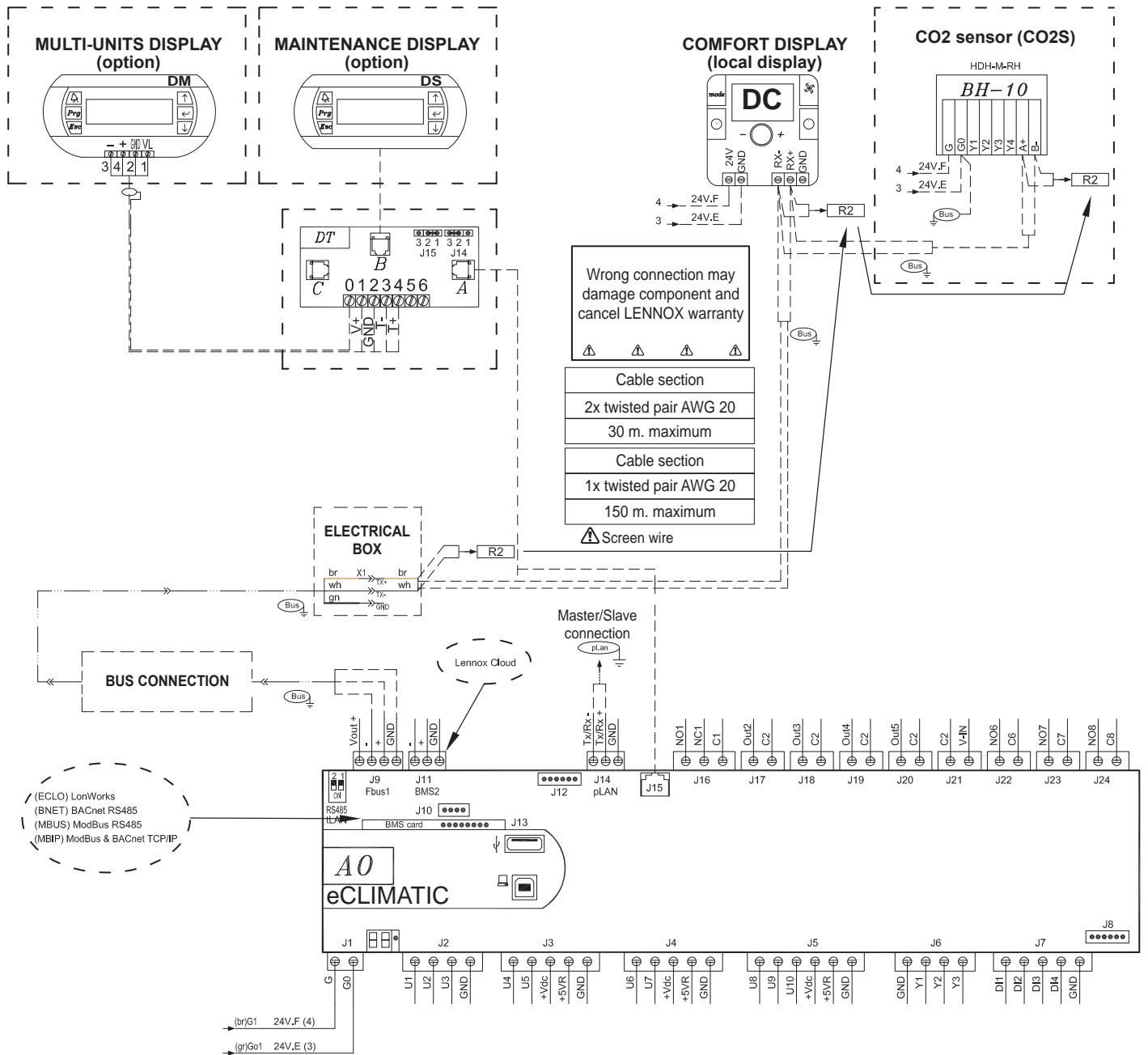

- For securing and connecting the Control Panel, consult the control panel Manual supplied with the unit.
- Connection between the DC and the unit must be made using shielded twisted pair cables (where the screen is connected to the earth by the side of the electrical panel) and with a two-lead cable.
- The Tx+ and Tx- polarities must strictly comply with the electrical diagram supplied with the unit.
- Wire the control. Minimum distance of 500 mm between control and power cables.
- Wire the control. Minimum distance of 500 mm between control and halogen lamps.
- Wire the control. Minimum distance of 500 mm between control and switchboard, antennas, transmitters...
- **NEVER ROLL UP THE EXCESSING CABLE, CUT THE CABLE FROM THE SIDE OF THE TERMINAL.**

TERMINAL CONNECTION WITH SPLIT UNIT

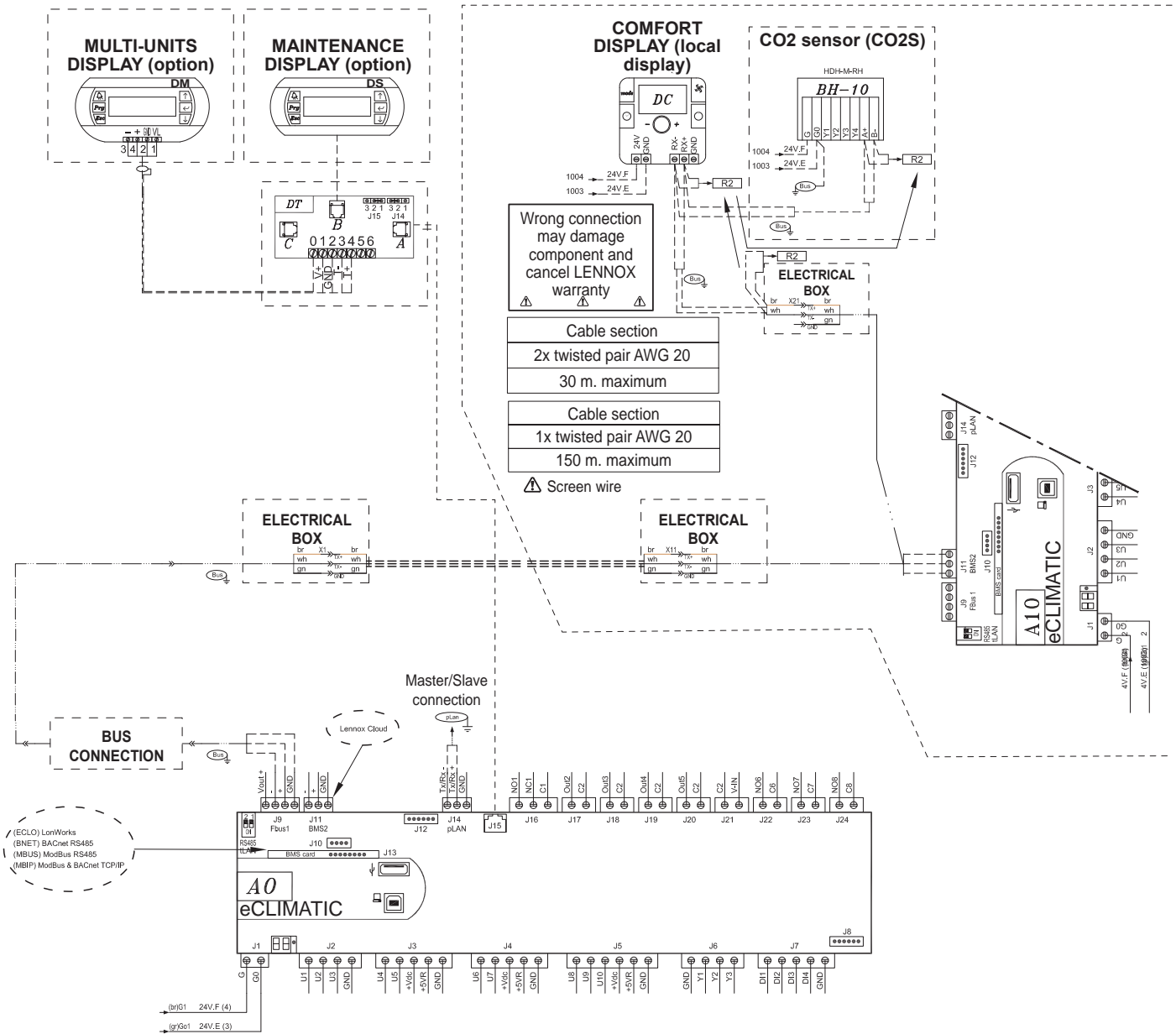

- For securing and connecting the Control Panel, consult the control panel Manual supplied with the unit.
- Connection between the DC and the unit must be made using shielded twisted pair cables (where the screen is connected to the earth by the side of the electrical panel) and with a two-lead cable.
- The Tx+ and Tx- polarities must strictly comply with the electrical diagram supplied with the unit.
- Wire the control. Minimum distance of 500 mm between control and power cables.
- Wire the control. Minimum distance of 500 mm between control and halogen lamps.
- Wire the control. Minimum distance of 500 mm between control and switchboard, antennas, transmitters...
- **NEVER ROLL UP THE EXCESSING CABLE, CUT THE CABLE FROM THE SIDE OF THE TERMINAL.**

PACKAGED UNITS

FAMH O20

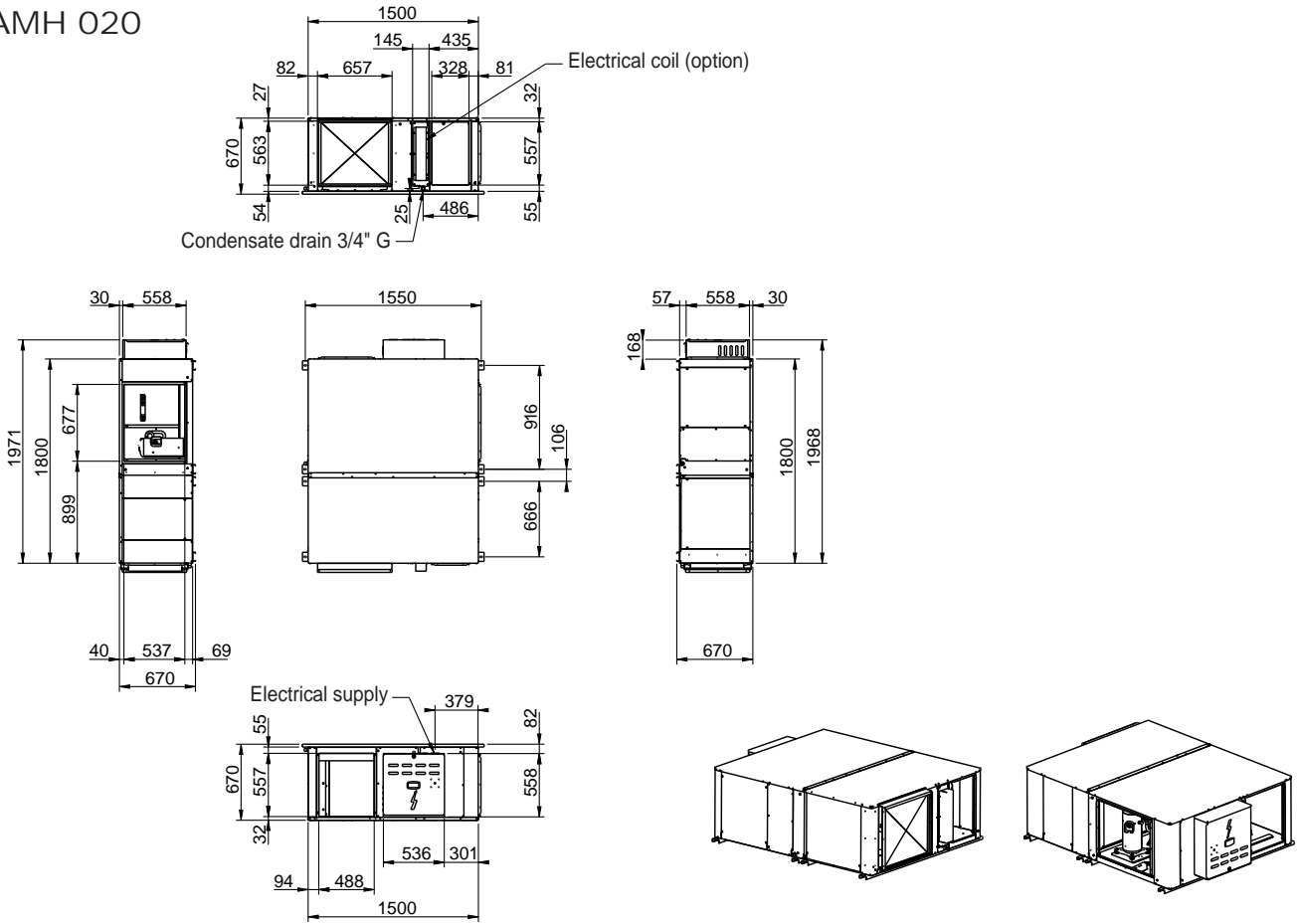

FAMH O35

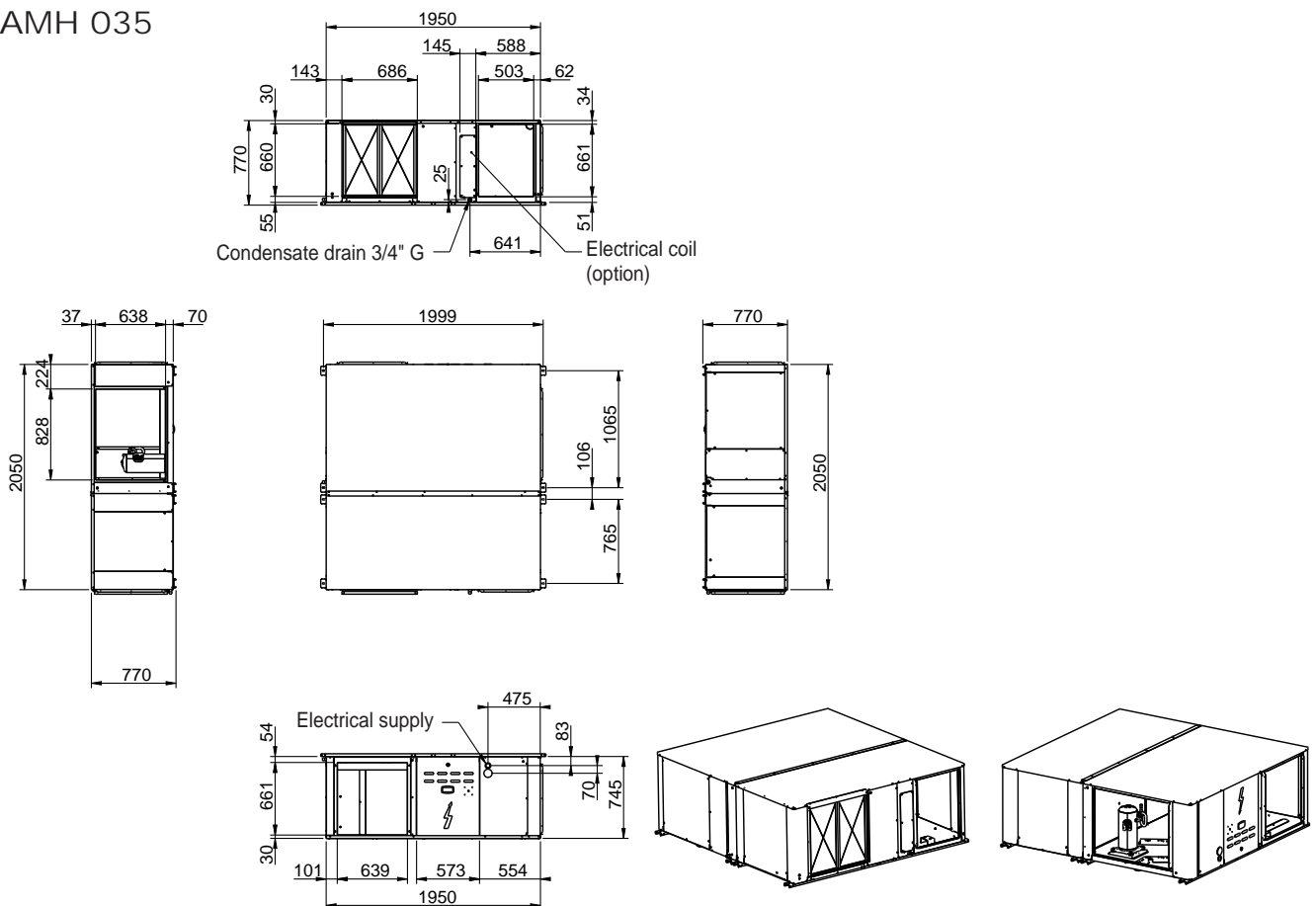

SPLIT UNITS

FAIH 020

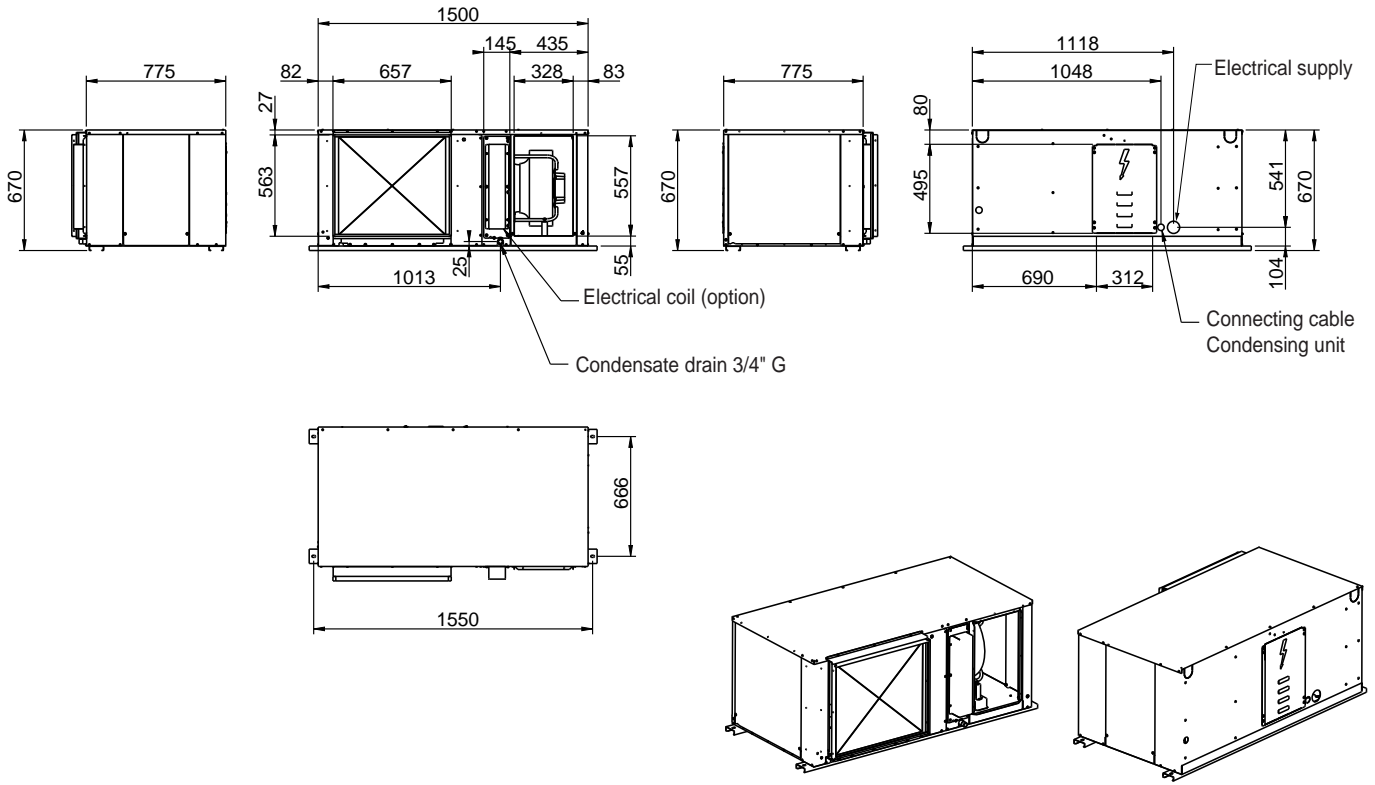

FASH 020

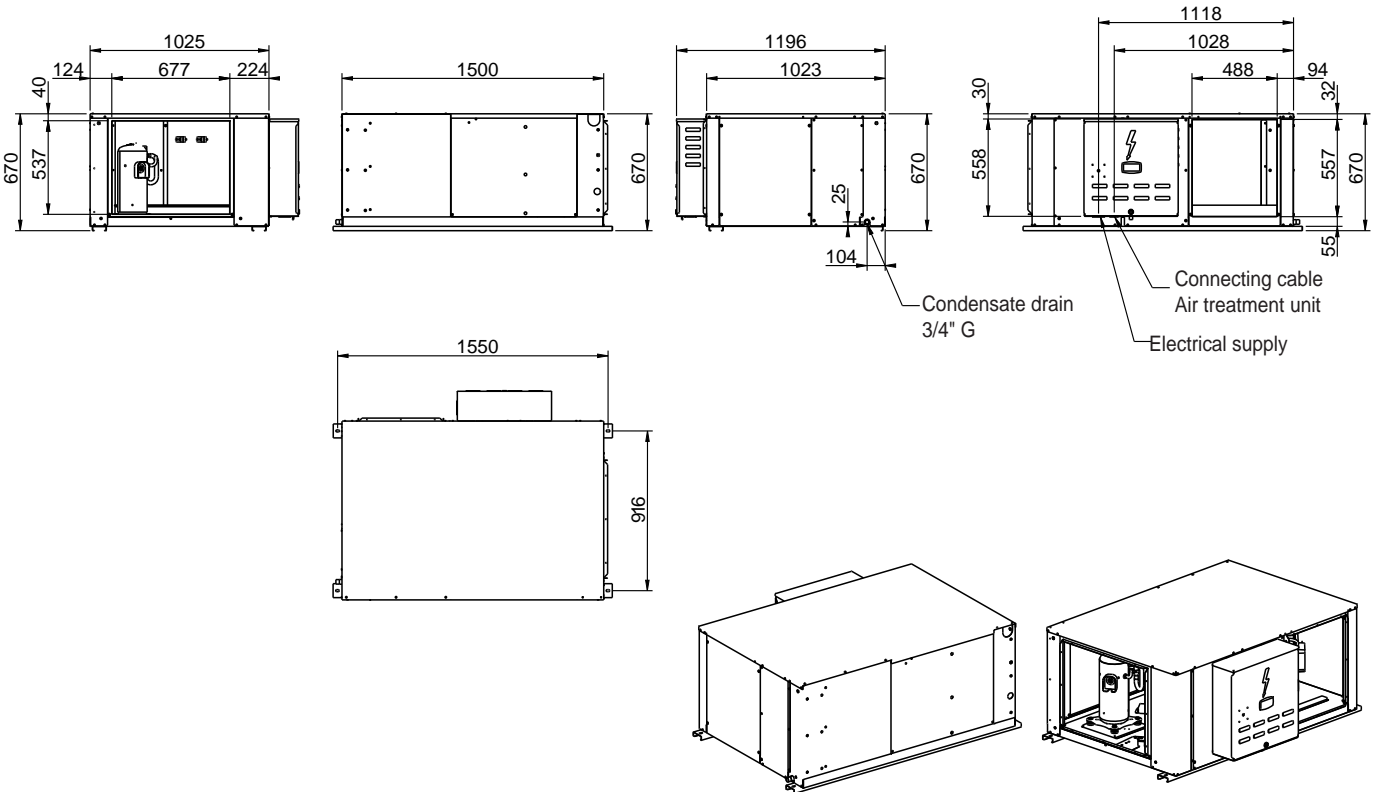

SPLIT UNITS

FAIH 035

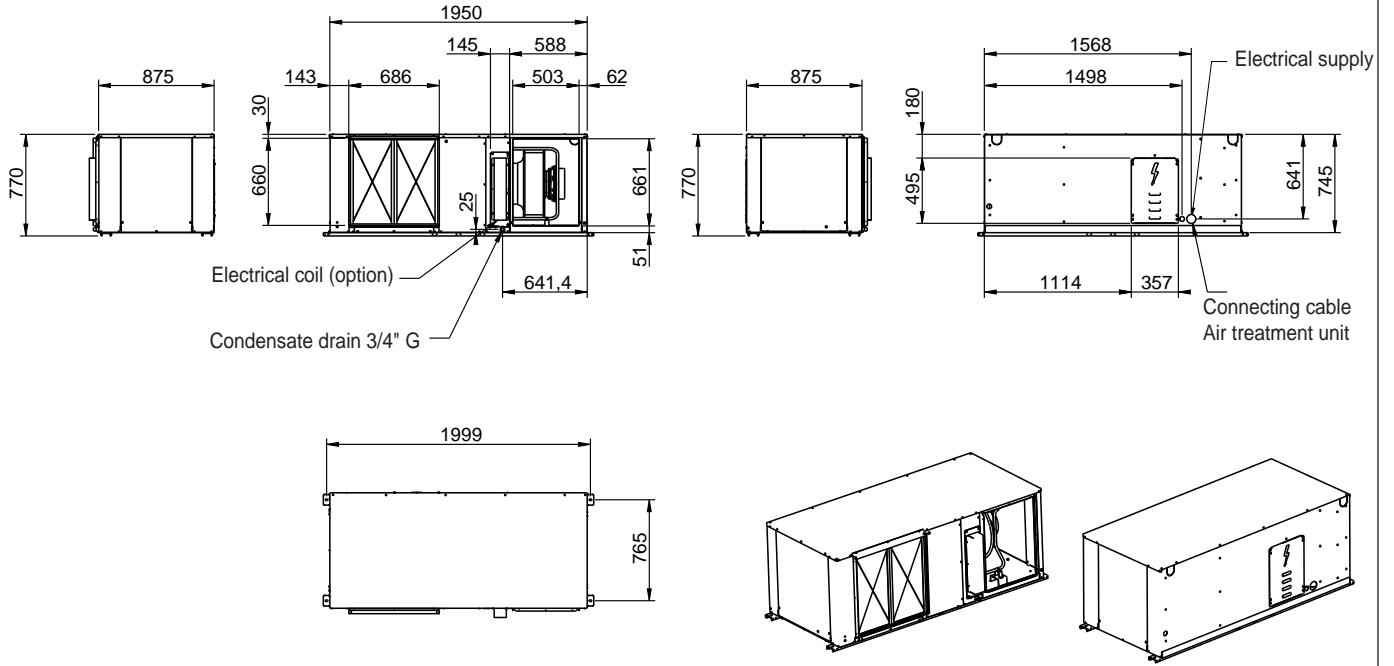

FASH 035

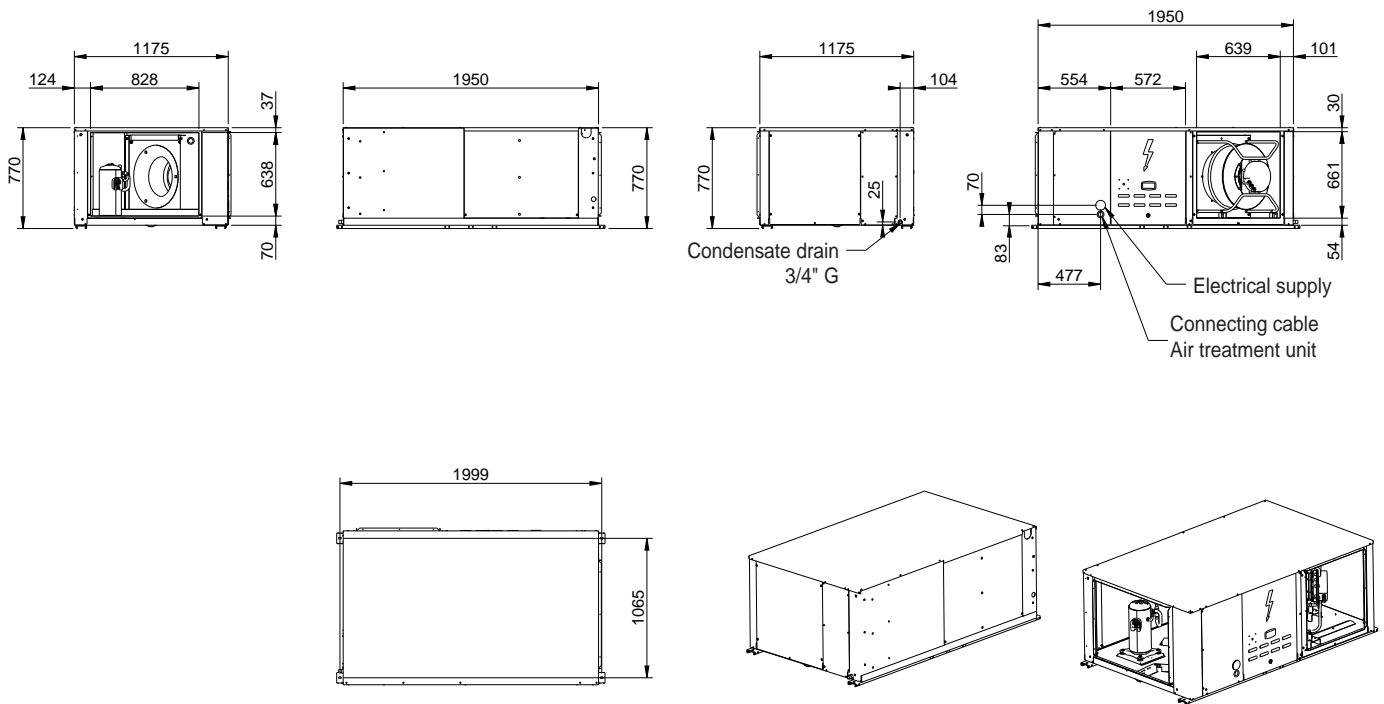

SALES OFFICES :

BELGIUM AND LUXEMBOURG

+32 3 633 3045

FRANCE

+33 1 64 76 23 23

GERMANY

+49 (0) 211 950 79 60

ITALY

+39 02 495 26 200

NETHERLANDS

+31 332 471 800

POLAND

+48 22 58 48 610

PORTUGAL

+351 229 066 050

SPAIN

+34 915 401 810

UKRAINE

+38 044 585 59 10

UNITED KINGDOM AND IRELAND

+44 1604 669 100

OTHER COUNTRIES :

LENNOX DISTRIBUTION

+33 4 72 23 20 20



Due to LENNOX EMEA ongoing commitment to quality, the specifications, ratings and dimensions are subject to change without notice and without incurring liability. Improper installation, adjustment, alteration, service or maintenance can cause property damage or personal injury. Installation and service must be performed by a qualified installer and servicing agency.

**FLATAIR ADV-
AGU-1801-E**



LENNOX