



Tranquility (THW) Water-To-Water Series

WATER-TO-WATER SYSTEMS
SIZES 8, 10, AND 12 kW
50 Hz UNITS

Tranquility Water-To-Water (THW) Series Features

The Tranquility High Temperature (THW) Series Water-to-Water Heat Pump

The THW Series is unlike any other water-to-water heat pump on the market today. The large operating map of the scroll compressor allows high temperature operation, up to 63°C leaving load water temperature even at 0°C entering source water temperature. The combination of a coaxial (tube-in-tube) heat exchanger for the source (ground loop) side and a brazed plate heat exchanger for the load (heating/hot water) side provides very high efficiencies. Integral controls for hydronic heating and domestic water heating avoid the need for external microprocessor-based controls for outdoor temperature reset, warm weather shutdown, staging and other controls.

Available in sizes 8kW, 10kW and 12kW, the THW offers a heat pump for most any installation. The THW has an extended range refrigeration circuit, capable of ground loop (geothermal) applications as well as open loop (well water) applications. Standard features and factory-installed options are many. Unique application-specific controls make the THW Series ideal for hydronic heating and domestic hot water generation. The heating-only refrigeration circuit is optimized for high water temperatures, heating efficiencies, and capacities.

ClimateMaster's exclusive double isolation compressor mounting system, insulated compressor enclosure, and compressor discharge muffler make the THW Series one of the quietest water-to-water heat pumps available. The attractive "Euro-style" cabinet allows the unit to fit into any decor.

Unit Features

- Sizes 8kW, 10kW, and 12kW
- High temperature scroll compressor; up to 63°C leaving water temperature
- Ultra high efficiencies (4.2 COP at ground loop conditions; up to 5.5 COP at ground water conditions!)
- Built-in programmable controller with Outdoor Temperature Reset and Warm Weather Shutdown
- Large, back-lit digital user interface
- Rugged coaxial (tube-in-tube) "Source" heat exchanger (copper or cupro-nickel)
- Close approach temperature brazed plate stainless steel "Load" heat exchanger
- Galvanized steel construction with protective powder coat paint and stainless steel, hinged front access door
- Unique double compressor isolation, compressor enclosure, and discharge muffler for UltraQuiet operation
- "Euro-style" cabinet for attractive look
- Hinged front access door and 3 removable panels for ease of installation and service
- Insulated cabinet with foil backed insulation for ease of cleaning
- Flush-mount 1" FPT fittings, secured to the cabinet (no backup wrench required)
- TXV metering device
- 12-point low voltage terminal strip for ease of installation
- Disconnect and CE Mark controls
- Wide variety of options including 3-way valve for domestic hot water generation, factory-installed internal load and source pump(s) and factory-installed expansion tanks.

Tranquility Water-To-Water (THW) Series Features

- 1 Euro-Style Cabinet For Attractive Look
- 2 High Temperature Scroll Compressor
- 3 Rugged Coaxial "Source" Heat Exchanger
- 4 Close Approach Temperature Brazed Plate Stainless Steel "Load" Heat Exchanger
- 5 Optional Full Condensing Hot Water Generation With 3-Way Valve
- 6 Optional Factory Installed "Load" and "Source" Pumps
- 7 Optional Factory Installed Expansion Tanks
- 8 Fully Insulated Water and Refrigerant Lines
- 9 Fully Insulated Compressor Section
- 10 Powder Coated Galvanized Steel Cabinet and Stainless Steel Front Access Panel For Long Life
- 11 Large Backlight User Interface
- 12 Built-In Programmable Controller With Outdoor Temperature Reset and Warm Weather Shutdown
- 13 Exclusive Double Compressor Isolation, Compressor Enclosure, and Compressor Discharge Muffler For UltraQuiet Operation
- 14 Hinged Front Access Door and Three Removable Panels For Ease of Installation and Service
- 15 12-Point Terminal Strip For Ease of Low Voltage Wiring (Thermistor Wiring and CE Mark Controls)
- 16 Service Disconnect



Tranquility Water-To-Water (THW) Series

Model Key

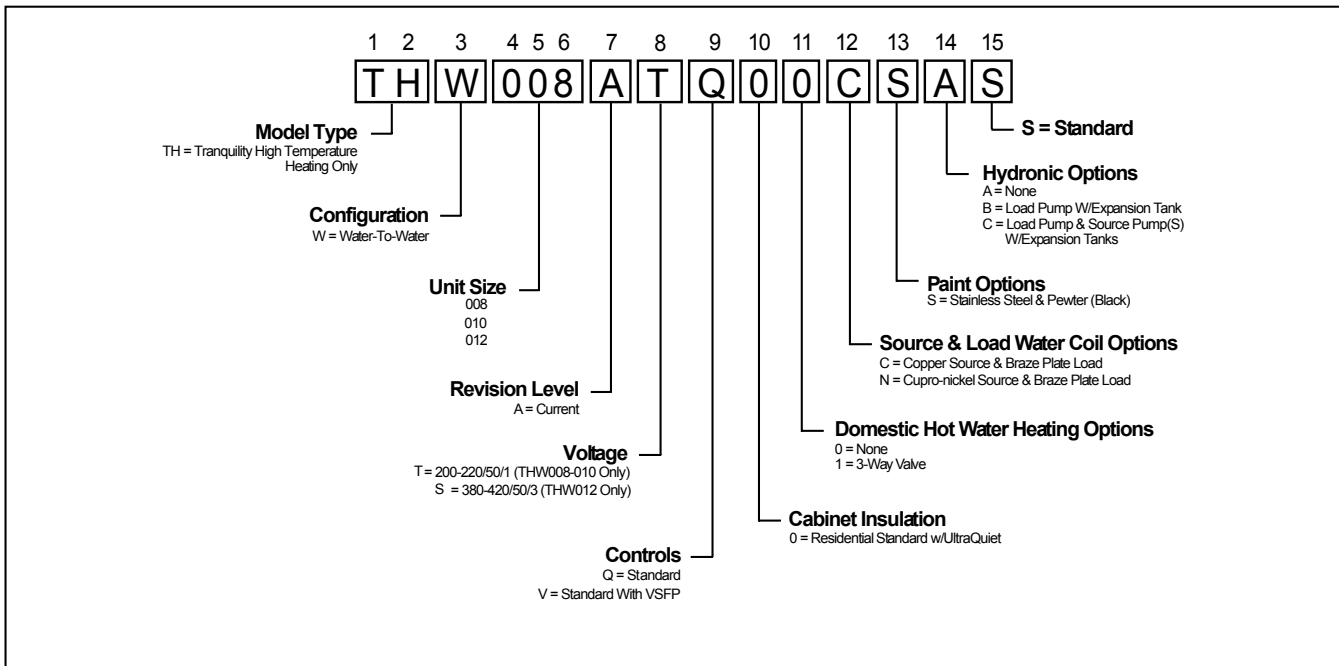

Rated Equipment Performance & Efficiencies

50Hz Units	Ground Loop Heat Pump				Ground Water Heat Pump			
Model	Heating				Heating			
	Indoor 30/35°C, Outdoor 0/-3°C*		Indoor 40/45°C, Outdoor 0/-3°C*		Indoor 30/35°C, Outdoor 10/7°C*		Indoor 40/45°C, Outdoor 10/7°C*	
	Capacity	COP	Capacity	COP	Capacity	COP	Capacity	COP
	kW	W/W	kW	W/W	kW	W/W	kW	W/W
THW008	7.81	4.2	7.20	3.2	10.68	5.5	9.85	4.2
THW010	9.84	4.2	9.29	3.2	12.85	5.2	12.02	4.1
THW012	13.15	4.2	12.44	3.3	15.74	4.8	15.69	4.1

*Indoor temperature is also called "Load;" outdoor temperature is also called "Source." Numbers shown with "/" indicate entering/leaving water temperatures. Bold outline indicates typical radiant floor application temperatures. All ratings are based upon standard EN 14511-2.

Tranquility Water-To-Water (THW) Series

Performance Data (50Hz) - THW008

50Hz - S-I Units

Source				Load												
EWT °C	Flow		WPD kPa	EWT °C	0.265 l/s [15.9 l/m]						0.353 l/s [21.2 l/m]					
	l/s	l/m			HC	Power	HE	LWT	COP	WPD	HC	Power	HE	LWT	COP	WPD
					kW	kW	kW	°C	W/W	kPa	kW	kW	kW	°C	W/W	kPa
-1	0.404	24.3	4.03	21	8.0	1.44	6.6	28.5	5.6	2.34	8.1	1.39	6.7	26.6	5.8	4.41
				32	7.4	1.98	5.4	39.0	3.7	1.79	7.5	1.93	5.5	37.3	3.9	3.72
				43	6.8	2.45	4.3	49.7	2.8	1.24	6.8	2.40	4.5	48.0	2.9	2.96
				54	6.2	3.03	3.1	60.1	2.0	0.97	6.2	2.99	3.2	58.7	2.1	2.48
10	0.404	24.3	3.28	21	10.8	1.48	9.3	31.2	7.3	2.34	10.9	1.40	9.5	28.4	7.8	4.41
				32	10.0	2.07	8.0	41.5	4.9	1.79	10.1	1.98	8.1	39.1	5.1	3.72
				43	9.2	2.57	6.7	52.0	3.6	1.24	9.3	2.49	6.8	49.7	3.7	2.96
				54	8.4	3.19	5.2	62.3	2.6	0.97	8.5	3.12	5.4	60.4	2.7	2.48
21	0.404	24.3	2.41	21	13.6	1.52	12.0	33.9	8.9	2.34	13.7	1.41	12.3	30.2	9.7	4.41
				32	12.7	2.15	10.5	44.1	5.9	1.79	12.8	2.04	10.8	40.8	6.3	3.72
				43	11.7	2.69	9.0	54.3	4.3	1.24	11.8	2.58	9.2	51.4	4.6	2.96
				54	10.7	3.36	7.3	64.4	3.2	0.97	10.8	3.24	7.6	62.0	3.3	2.48

THW operating parameters are as follows: Min Source EWT = -6°C; Max Load LWT = 63°C (see application section for design guidelines).

Interpolation is permissible; extrapolation is not.

Operation below 4°C EWT (source) is based upon 15% antifreeze solution.

All performance data is based upon the lower voltage of dual voltage units.

Antifreeze for source water is required for operation in the shaded area and all source EWTs below 4°C.

Performance Data (50Hz) - THW010

50Hz - S-I Units

Source				Load												
EWT °C	Flow		WPD kPa	EWT °C	0.341 l/s [20.5 l/m]						0.461 l/s [27.7 l/m]					
	l/s	l/m			HC kW	Power kW	HE kW	LWT °C	COP W/W	WPD kPa	HC kW	Power kW	HE kW	LWT °C	COP W/W	WPD kPa
-1	0.524	31.5	5.68	21	10.4	1.86	8.6	28.8	5.6	4.20	10.5	1.79	8.7	26.8	5.9	7.79
				32	9.6	2.56	7.1	39.3	3.8	3.45	9.7	2.50	7.2	37.6	3.9	6.68
				43	8.8	3.15	5.7	50.0	2.8	2.69	8.9	3.01	5.8	48.3	2.9	5.65
				54	8.0	3.91	4.1	60.5	2.1	2.21	8.1	3.85	4.2	59.1	2.1	4.82
10	0.524	31.5	4.90	21	14.0	1.91	12.1	31.5	7.3	4.20	14.2	1.81	12.4	28.6	7.8	7.79
				32	13.0	2.67	10.4	41.8	4.9	3.45	13.2	2.56	10.6	39.3	5.1	6.68
				43	12.0	3.31	8.7	52.3	3.6	2.69	12.1	3.21	8.9	50.1	3.8	5.65
				54	11.0	4.12	6.8	62.7	2.7	2.21	11.1	4.02	7.1	60.8	2.8	4.82
21	0.524	31.5	4.03	21	17.6	1.97	15.7	34.2	9.0	4.20	17.8	1.82	16.0	30.5	9.8	7.79
				32	16.5	2.77	13.7	44.4	5.9	3.45	16.6	2.63	14.0	41.1	6.3	6.68
				43	15.2	3.48	11.7	54.6	4.4	2.69	15.4	3.33	12.0	51.8	4.6	5.65
				54	13.9	4.33	9.6	64.8	3.2	2.21	14.0	4.19	9.9	62.4	3.4	4.82

THW operating parameters are as follows: Min Source EWT = -6°C; Max Load LWT = 63°C (see application section for design guidelines).

Interpolation is permissible; extrapolation is not.

Operation below 4°C EWT (source) is based upon 15% antifreeze solution.

All performance data is based upon the lower voltage of dual voltage units.

Antifreeze for source water is required for operation in the shaded area and all source EWTs below 4°C.

Tranquility Water-To-Water (THW) Series

Performance Data (50Hz) - THW012

50Hz - S-I Units

Source				Load												
EWT °C	Flow		WPD kPa	EWT °C	0.423 l/s [25.4 l/m]						0.562 l/s [33.7 l/m]					
	l/s	l/m			HC	Power	HE	LWT	COP	WPD	HC	Power	HE	LWT	COP	WPD
					kW	kW	kW	°C	W/W	kPa	kW	kW	kW	°C	W/W	kPa
-1	0.644	38.7	6.09	21	12.9	2.36	10.6	29.0	5.5	6.48	13.0	2.27	10.8	27.0	5.7	10.61
				32	11.9	3.25	8.7	39.6	3.7	5.51	12.0	3.17	8.9	37.9	3.8	9.51
				43	10.9	4.01	6.9	50.4	2.7	4.55	11.0	3.93	7.1	48.7	2.8	8.41
				54	9.9	4.97	5.0	60.9	2.0	3.93	10.0	4.89	5.2	59.5	2.1	7.51
10	0.644	38.7	5.02	21	17.4	2.43	15.0	31.7	7.2	6.48	17.6	2.29	15.3	28.9	7.7	10.61
				32	16.2	3.39	12.8	42.1	4.8	5.51	16.3	3.25	13.1	39.6	5.0	9.51
				43	14.9	4.21	10.7	52.7	3.5	4.55	15.0	4.08	11.0	50.4	3.7	8.41
				54	13.6	5.23	8.4	63.1	2.6	3.93	13.7	5.10	8.6	61.2	2.7	7.51
21	0.644	38.7	4.29	21	21.9	2.50	19.4	34.4	8.8	6.48	22.1	2.31	19.8	30.7	9.6	10.61
				32	20.4	3.52	16.9	44.7	5.8	5.51	20.6	3.33	17.3	41.4	6.2	9.51
				43	18.9	4.41	14.4	55.0	4.3	4.55	19.0	4.23	14.8	52.1	4.5	8.41
				54	17.2	5.50	11.7	65.2	3.1	3.93	17.4	5.32	12.1	62.8	3.3	7.51

THW operating parameters are as follows: Min Source EWT = -6°C; Max Load LWT = 63°C (see application section for design guidelines).
Interpolation is permissible; extrapolation is not.

Operation below 4°C EWT (source) is based upon 15% antifreeze solution.

All performance data is based upon the lower voltage of dual voltage units.

Antifreeze for source water is required for operation in the shaded area and all source EWTs below 4°C.

Physical Data

Model	008	010	012
Compressor (qty)	Scroll (1)		
Factory Charge HFC-410A [kg]	2.51	2.50	2.84
Indoor/Load Water Connection Size			
FPT	1	1	1
Outdoor/Source Water Connection Size			
FPT	1	1	1
Domestic Hot Water Connection Size			
FPT	1	1	1
Weight - Operating, [kg]	207	207	234
Weight - Packaged, [kg]	214	214	241

Dual isolation compressor mounting
 Balanced Port Expansion Valve (TXV)
 Insulated Source and Load Water Coils
 FPT - Female Pipe Thread

THW Dimensions

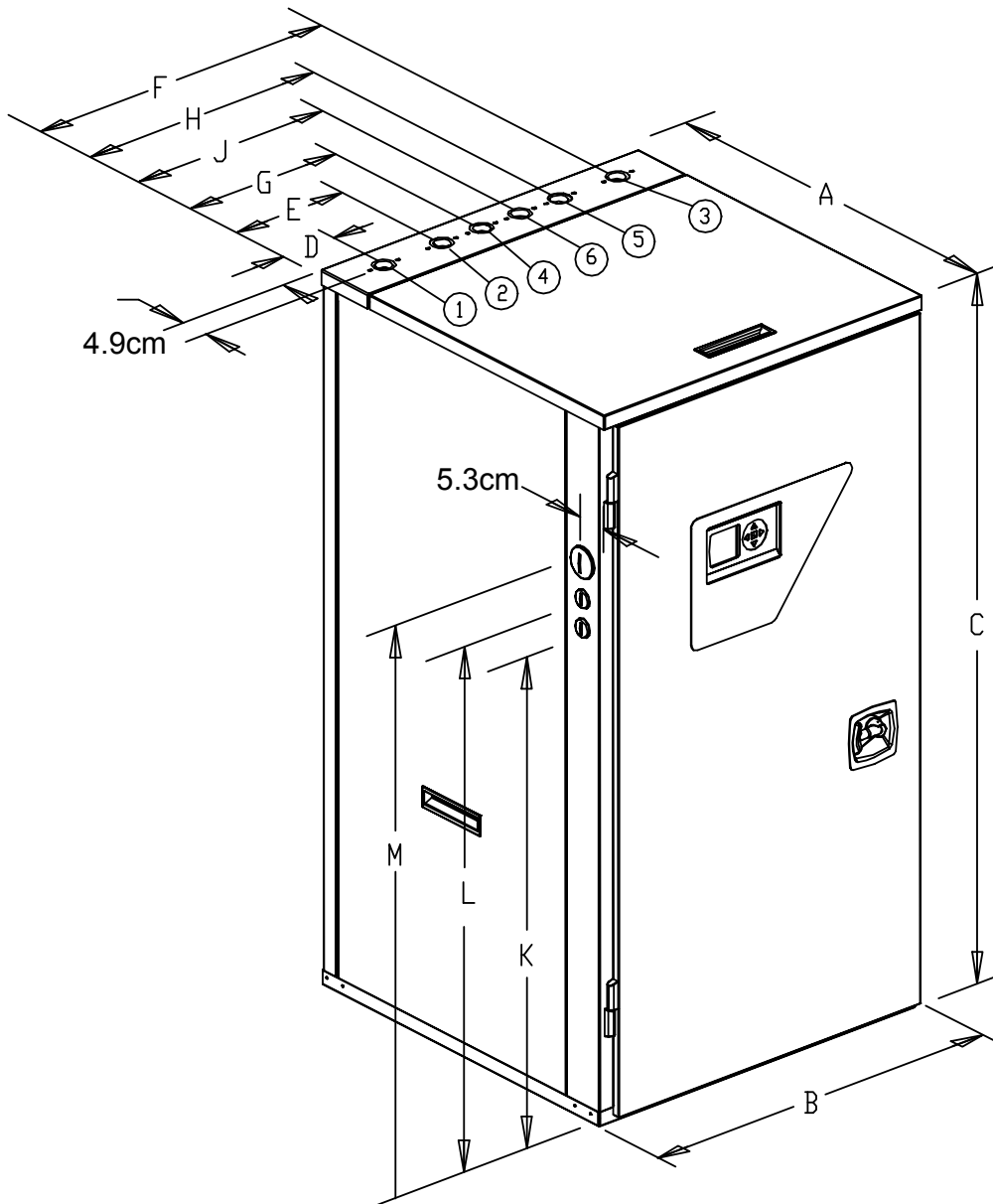

Model	Overall Cabinet			Water Connections						Electric Access Plugs			
	A Depth	B Width	C Height	1	2	3	4	5	6	K Low Voltage	L Low Voltage	M Power Supply	
				D Source (Outdoor) Water In	E Source (Outdoor) Water Out	F Load (Indoor) Water In	G Load (Indoor) Water Out	H DHW Return In	J DHW Water Out				
008	cm.	68.1	65.1	124.2	8.6	20.6	56.6	28.7	45.0	36.6	85.3	90.4	96.5
010	cm.	68.1	65.1	124.2	8.6	20.6	56.6	28.7	45.0	36.6	85.3	90.4	96.5
012	cm.	68.1	65.1	124.2	8.6	20.6	56.6	28.7	45.0	36.6	85.3	90.4	96.5

Electrical Data

Model	Voltage Code	Voltage	Min/Max Voltage	Compressor			Load Pump FLA	Source Pump (1) FLA	Source Pump (2) FLA	Total Unit FLA	Min Circuit Amps	Max Fuse
				Qty	RLA	LRA						
THW008	T	200-220/50/1	190/242	1	18.9	94	-	-	-	18.9	23.6	40
							0.8	-	-	19.7	24.4	40
							0.8	0.8	-	20.5	25.2	40
	S	380-420/50/3	361/462	1	6.6	39	-	-	-	6.6	8.3	15
							0.8	-	-	7.4	9.1	15
							0.8	0.8	-	8.2	9.9	15
THW010	T	200-220/50/1	190/242	1	24.7	121	-	-	-	24.7	30.9	50
							0.8	-	-	25.5	31.7	50
							0.8	0.8	0.8	27.1	33.3	50
	S	380-420/50/3	361/462	1	7.9	41	-	-	-	7.9	9.9	15
							0.8	-	-	8.7	10.7	15
							0.8	0.8	0.8	10.3	12.3	20
THW012	S	380-420/50/3	361/462	1	9.8	70	-	-	-	9.8	12.3	20
							1.07	-	-	10.9	13.3	20
							1.07	1.07	1.07	13	15.5	25

Wiring Diagram Matrix

Model	Diagram Number	Voltage	Option
THW008	96B0108N01	220/50/1	-
THW008	96B0108N02	220/50/1	VSFP
THW012	97B0108N03	380-420/50/3	-
THW012	97B0108N04	380-420/50/3	VSFP

Tranquility Water-To-Water (THW) Series

THW008 - 012 Electrical Wiring Diagram - 220/50/1 96B0108N01

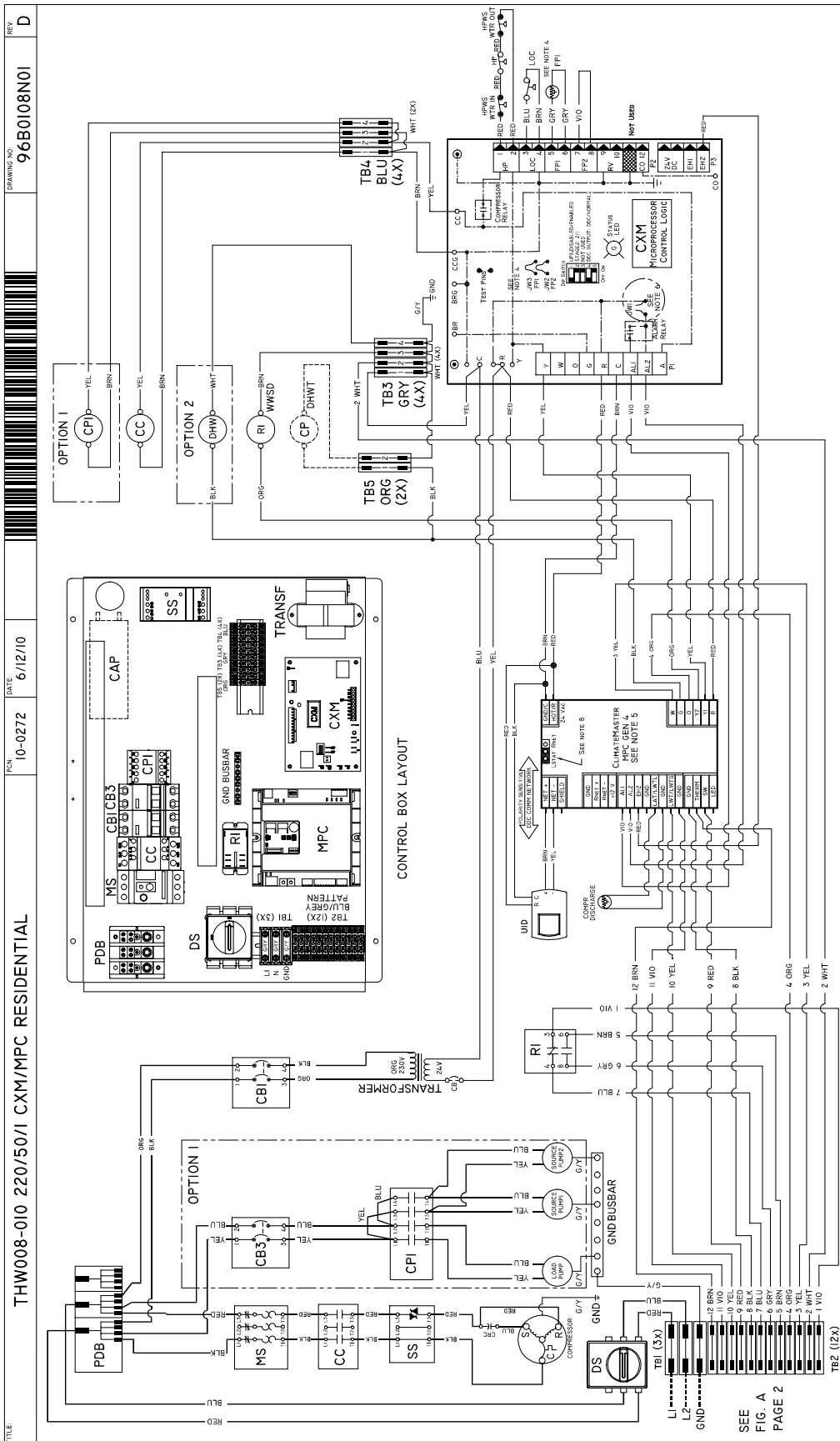

THW008 - 012 Electrical Wiring Diagram - 220/50/1 96B0108N01

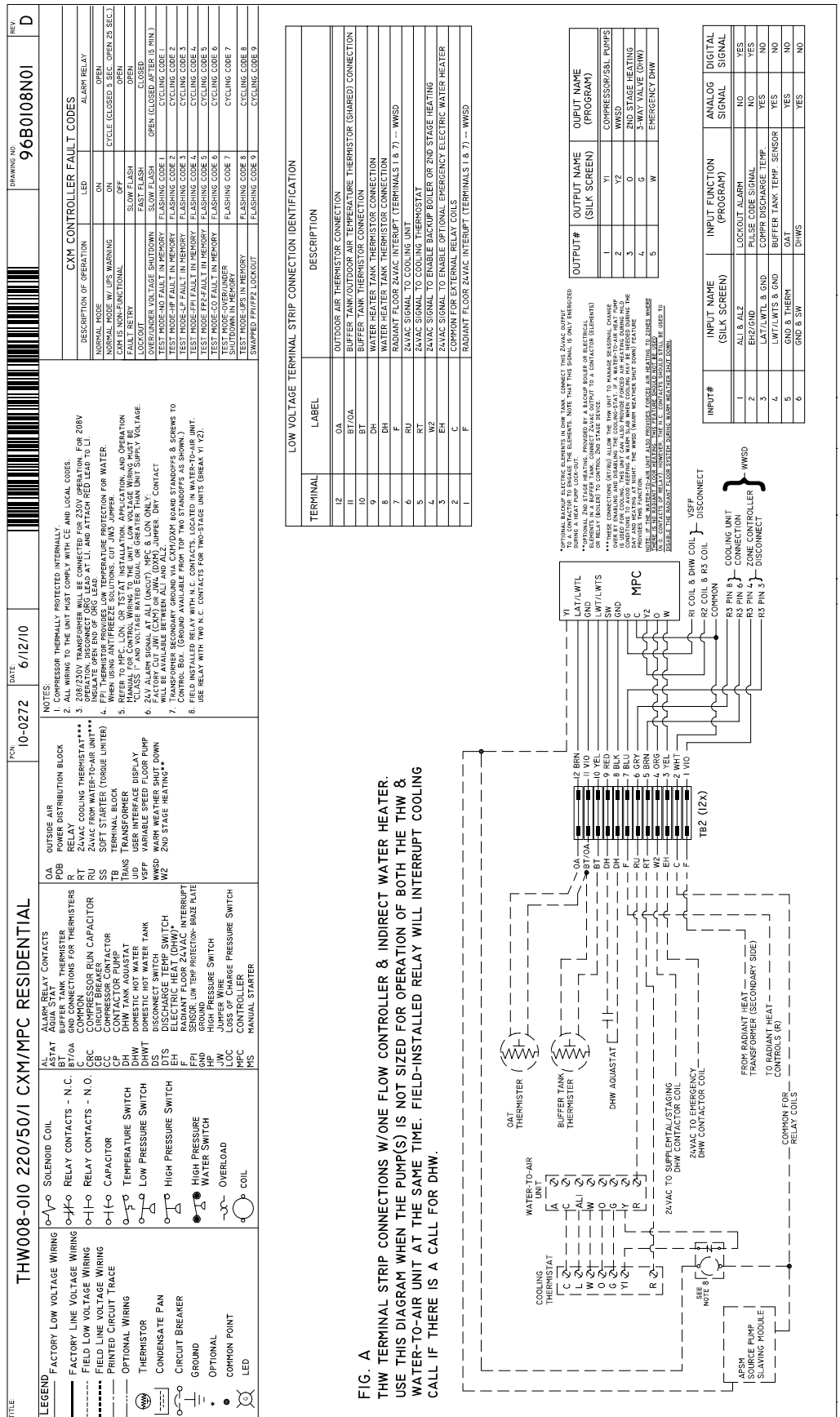

Tranquility Water-To-Water (THW) Series

THW008 - 012 Electrical Wiring Diagram - 220/50/1 VSFP - 96B0108N02

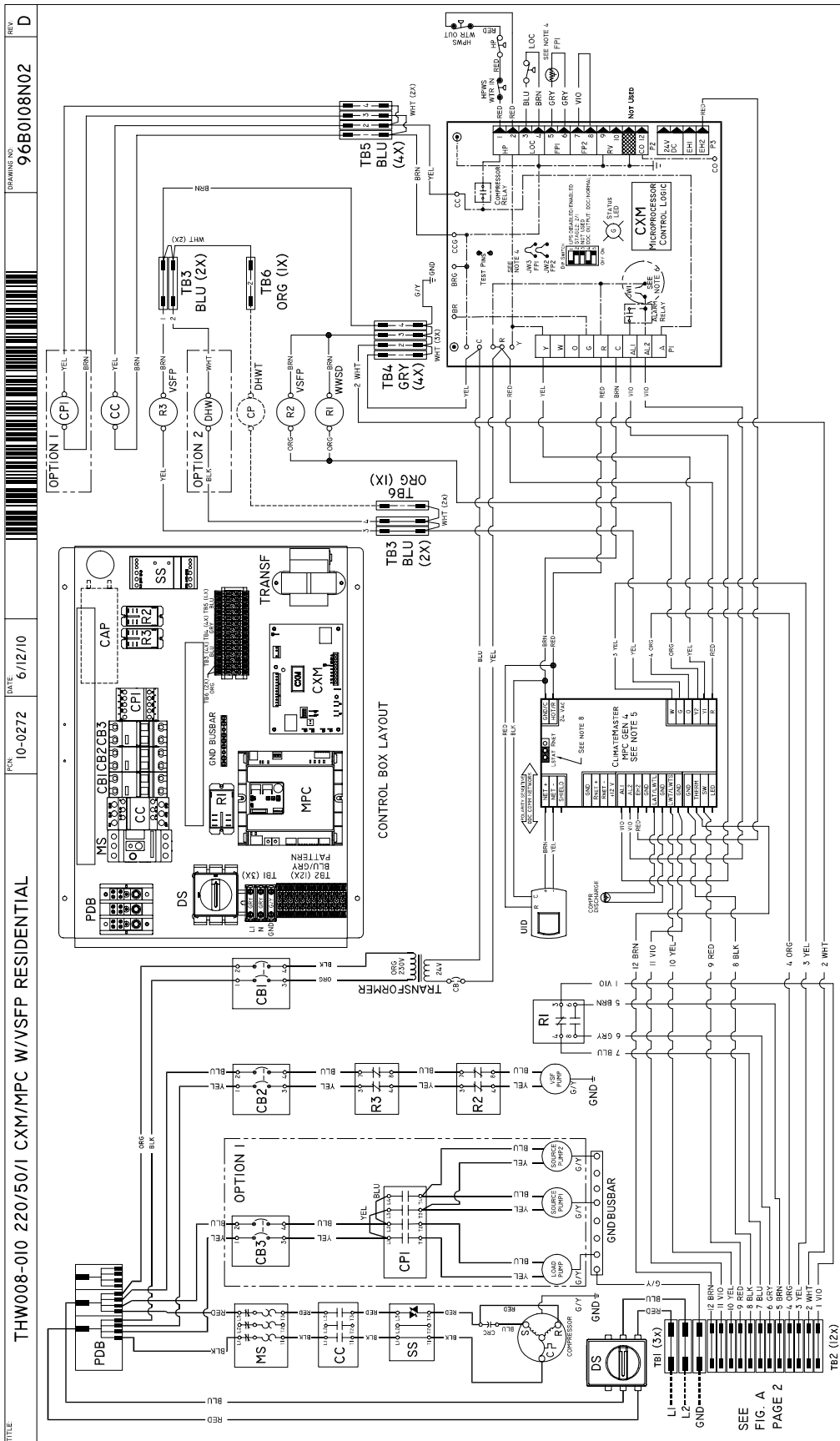

THW008 - 012 Electrical Wiring Diagram - 220/50/1 VSFP - 96B0108N02

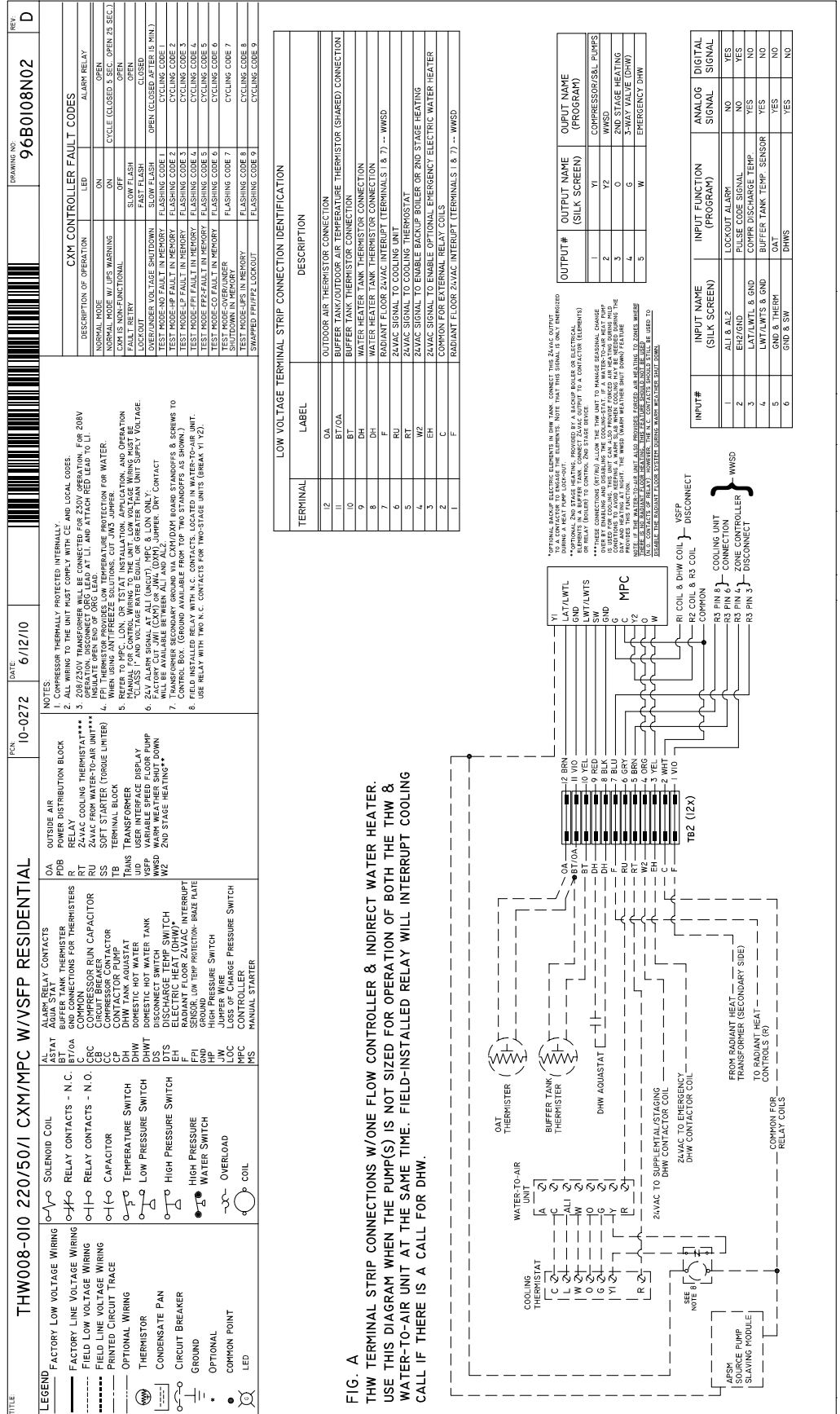

Tranquility Water-To-Water (THW) Series

THW008 - 012 Electrical Wiring Diagram - 420/50/3 96B0108N03

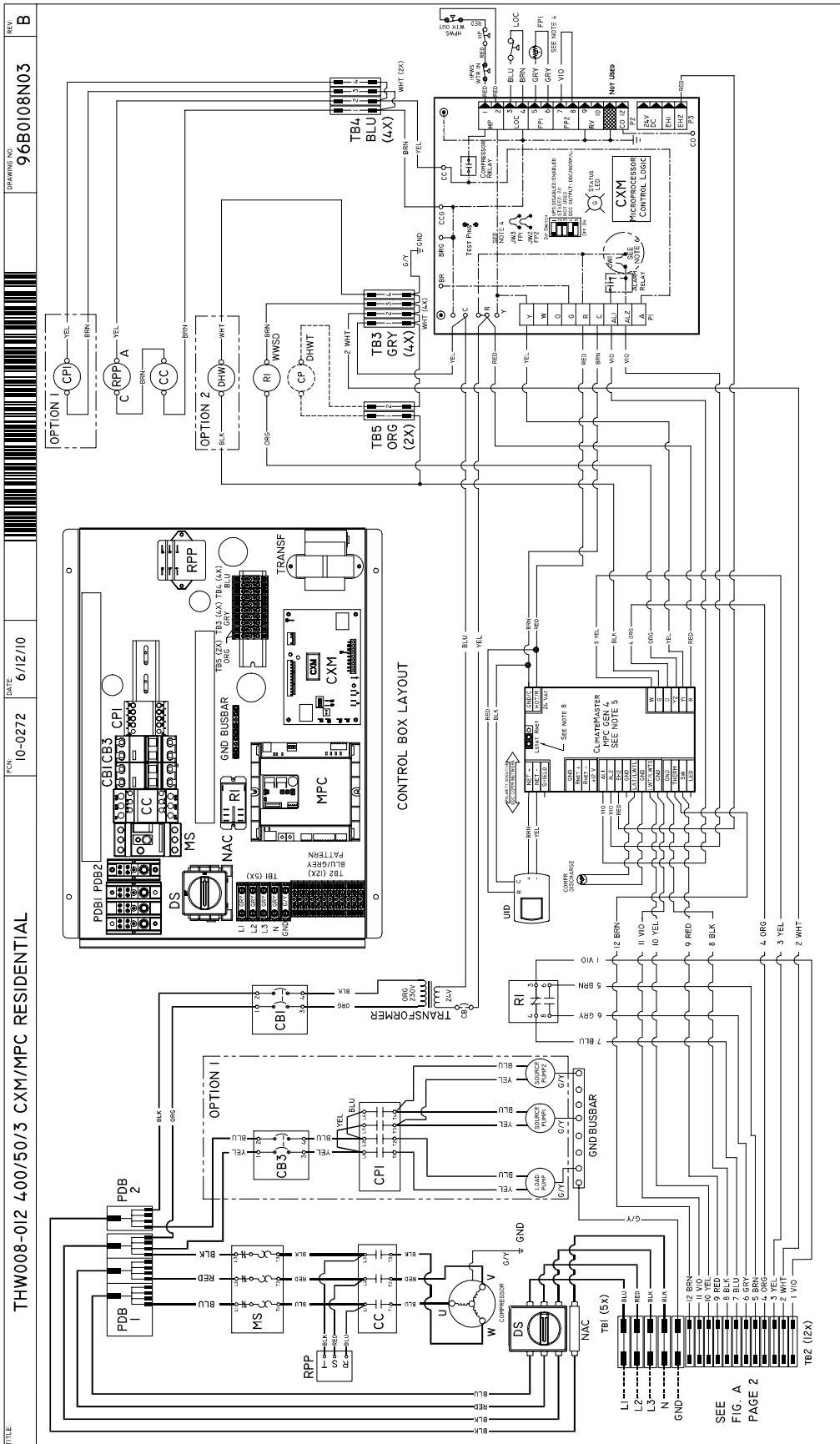

THW008 - 012 Electrical Wiring Diagram - 420/50/3 96B0108N03

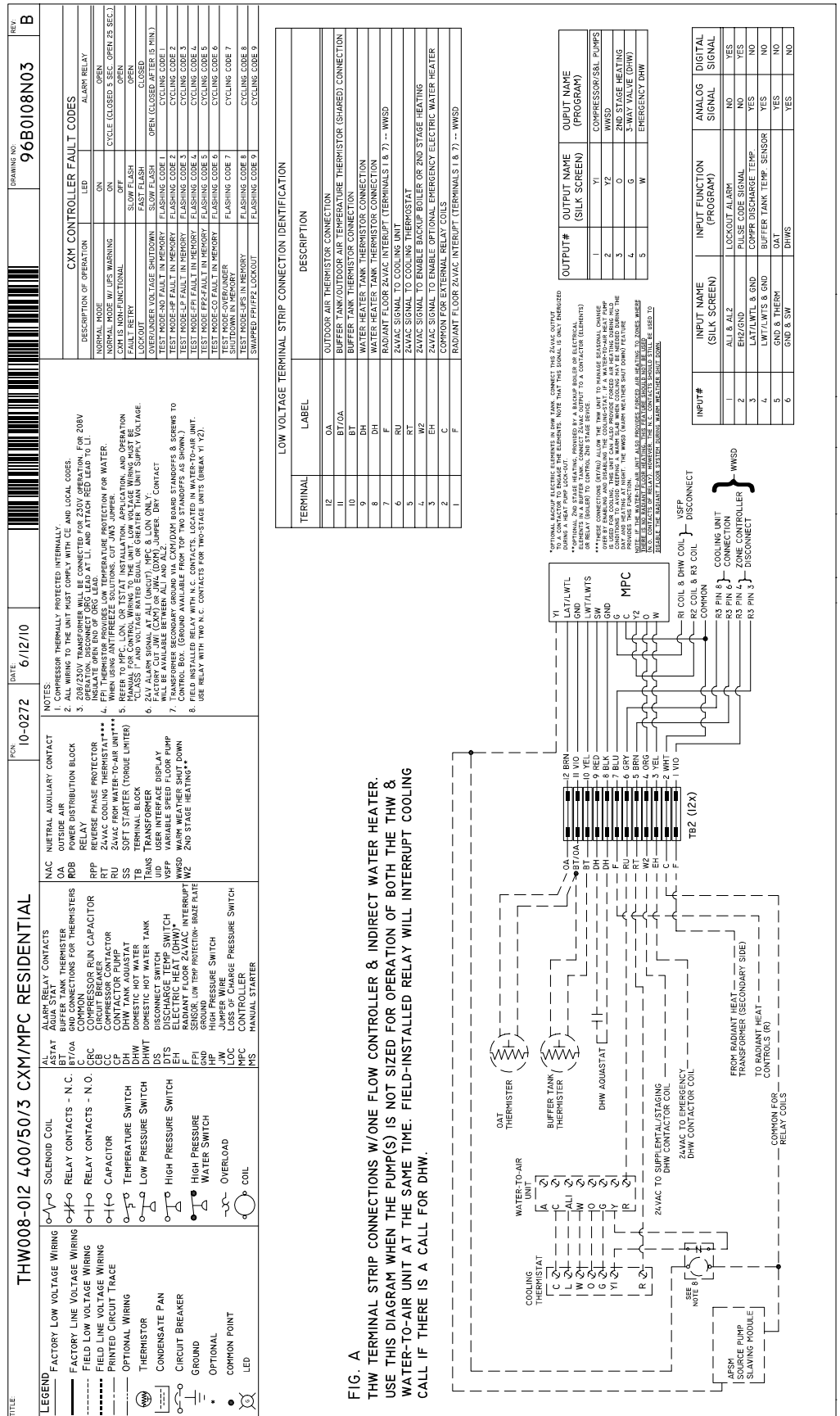

FIG. A

THW TERMINAL STRIP CONNECTIONS W/ ONE FLOW CONTROLLER & INDIRECT WATER HEATER.

USE THIS DIAGRAM WHEN THE PUMP(S) IS NOT SIZED FOR OPERATION OF BOTH THE THW & WATER-TO-AIR UNIT AT THE SAME TIME. FIELD-INSTALLED RELAY WILL INTERRUPT COOLING CALL IF THERE IS A CALL FOR DHW.

FIG. B

THW TERMINAL STRIP CONNECTIONS W/ ONE FLOW CONTROLLER & DIRECT WATER HEATER.

USE THIS DIAGRAM WHEN THE PUMP(S) IS NOT SIZED FOR OPERATION OF BOTH THE THW & WATER-TO-AIR UNIT AT THE SAME TIME. FIELD-INSTALLED RELAY WILL INTERRUPT COOLING CALL IF THERE IS A CALL FOR DHW.

Tranquility Water-To-Water (THW) Series

THW008 - 012 Electrical Wiring Diagram - 420/50/3 VSFP - 96B0108N04

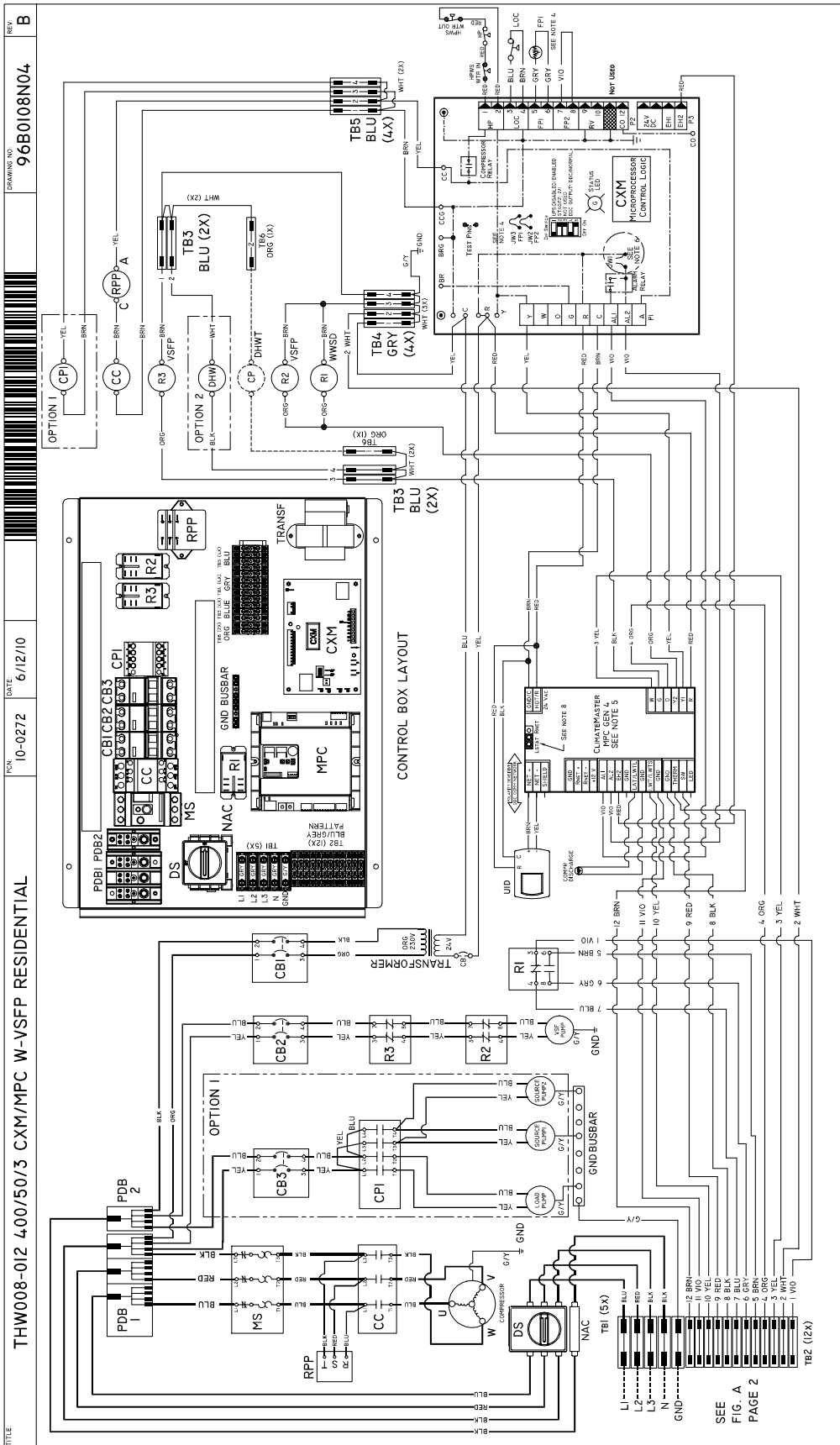

THW008 - 012 Electrical Wiring Diagram - 420/50/3 VSFP - 96B0108N04

DRAWING NO. 96B0108N04	DATE 6/12/10	REV. B
THW008-012 400/50/3 CXM/MPC W-VSFP RESIDENTIAL		
LEGEND FACTORY LOW VOLTAGE WIRING FIELD LOW VOLTAGE WIRING PRINTED CIRCUIT TRACE THERMISTOR CONDENSATE FAN CIRCUIT BREAKER GROUND OPTIONAL COMMON POINT LED	AL-STAT BU-STAT BT/OA C CC CCB CC DH DHWT DS DS EHS F GND HP JWP JWP MPC MS	NAC OOA PDB RPP R RPP RU RU SS TB TRANS UD UD WKSD WKSD WZ
NOTES: 1. COMPRESSOR THERMALLY PROTECTED INTERNALLY. 2. ALL WIRING TO THE UNIT MUST COMPLY WITH CE AND LOCAL CODES. 3. 208/230V TRANSFORMER MUST BE CONNECTED FOR 230V OPERATION OR 208V OPERATION. (SEE THE TRANSFORMER WIRING DIAGRAM FOR WIRING TO THE TRANSFORMER.) 4. INSULATE OPEN END OF ORG LEAD. 5. WHEN USING ANTI-FREEZE SOLUTIONS CUT MAX JUMPER FOR WATER. 6. ZAV ALARM SIGNAL AT ALL (SAGC), HP & LON ONLY. 7. TRANSFORMER SECONDARY GROUND VIA CMM/DXN BOARD STANDOFFS & SCREWS TO CONTROL BOX. (GROUND AVAILABLE FROM TOP TWO STANDOFFS AS SHOWN IN FIG. 1.) 8. USE RELAY WITH TWO N.C. CONTACTS FOR TWO STAGE UNITS (BREAK Y1 Y2).		

TERMINAL	LABEL	DESCRIPTION
12	OA	OUTDOOR AIR THERMISTOR CONNECTION
11	BT/OA	BUFFER TANK/OUTDOOR AIR TEMPERATURE THERMISTOR (SHARED) CONNECTION
10	BT	BUFFER TANK THERMISTOR CONNECTION
9	BT	WATER HEATER TANK THERMISTOR CONNECTION
8	DH	WATER HEATER TANK THERMISTOR CONNECTION
7	F	24VAC SIGNAL TO COOLING UNIT
6	BT	24VAC SIGNAL TO COOLING UNIT
5	BT	24VAC SIGNAL TO COOLING THERMOSTAT
4	WZ	24VAC SIGNAL TO ENABLE BACKUP BOILER OR 2ND STAGE HEATING
3	EH	24VAC SIGNAL TO ENABLE OPTIONAL EMERGENCY ELECTRIC WATER HEATER
2	C	COMMON FOR EXTERNAL RELAY COILS
1	F	RADIANT FLOOR 24VAC INTERUPT (TERMINALS 1 & 7) -- WWSW

TERMINAL	LABEL	DESCRIPTION
1	Y1	COMPRESSOR/SBL PUMPS
2	Y2	WWSW
3	0	2ND STAGE HEATING
4	G	EMERGENCY DHW
5	W	EMERGENCY DHW

FIG. A
 THW TERMINAL STRIP CONNECTIONS W/ONE FLOW CONTROLLER & INDIRECT WATER HEATER.
 USE THIS DIAGRAM WHEN THE PUMP(S) IS NOT SIZED FOR OPERATION OF BOTH THE THW & WATER-TO-AIR UNIT AT THE SAME TIME. FIELD-INSTALLED RELAY WILL INTERRUPT COOLING CALL IF THERE IS A CALL FOR DHW.

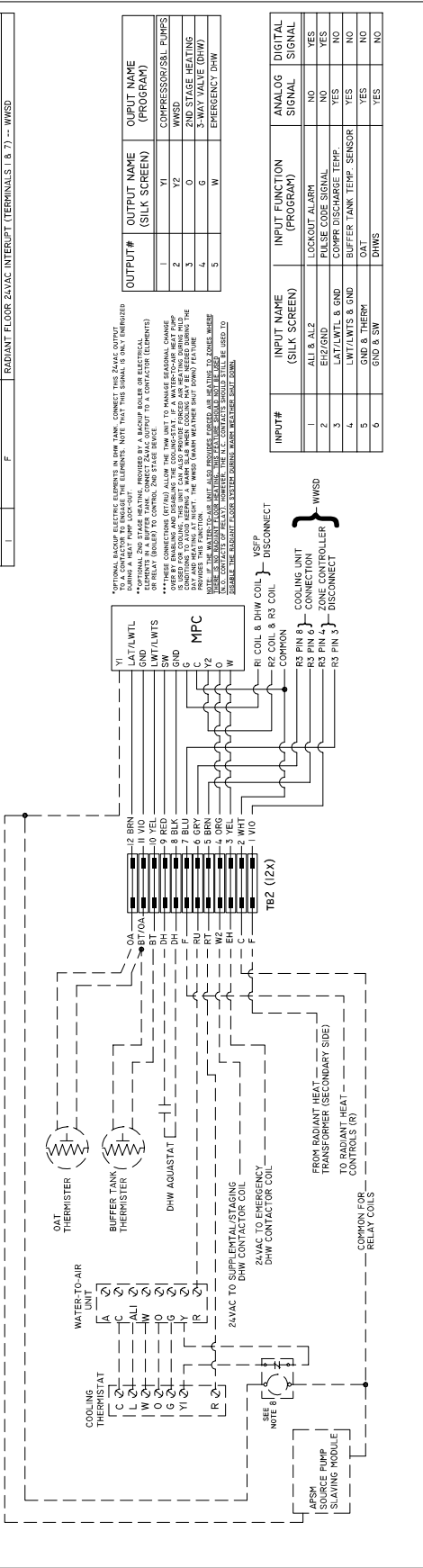

Engineering Guide Specifications

General

The water-source heating units shall be high temperature water-to-water heat pumps. Units shall be performance rated in accordance with EN 14511-2 or AHRI/ISO/ASHRAE 13256-2. Units shall include CE mark. Each unit shall be water run-tested at the factory. The quality control system shall automatically perform via computer: triple leak check, pressure tests, evacuate and accurately charge system, perform detailed heating mode tests, and quality cross check all operational and test conditions to pass/fail data base. Each unit shall be pallet mounted and shipped with appropriate protective packaging to help avoid damage in transportation.

The units shall be warranted by the manufacturer against defects in materials and workmanship for a period of twelve (12) months from the date of unit start-up or eighteen (18) months from the date of shipment (from CM's factory), whichever comes first. Optional extended warranties are available. The water source units shall be designed to operate with entering Source temperature between -7 and 32°C, and entering Load temperature between 10 and 54°C with a maximum leaving load temperature of 63°C.

Casing & Cabinet

The cabinet shall be fabricated from heavy-gauge galvanized steel and painted with a polyester powder coating. Access door shall be stainless steel and hinged for easy access. The interior shall be insulated with 13mm thick, multi-density, foil-backed coated glass fiber. Four access panels shall be provided and shall be removable with piping in place. The internal component layout shall provide for major service with the unit in place for restricted access installations. The units shall have an insulated compressor section to minimize the transmission of compressor noise.

Refrigerant Circuit

All units shall contain EarthPure® (HFC-410A) sealed refrigerant circuit employing a hermetic motor-compressor, thermal expansion valve, coaxial tube water-to-refrigerant Source heat exchanger, brazed plate Load heat exchanger, compressor discharge muffler, 100% molecular sieve filter drier with XH-11 desiccant, and service ports. An optional 3-way Domestic Hot Water valve shall be available. Compressors shall be scroll type designed for heat pump duty and shall be double isolated from the cabinet with two sets of compressor mounting hardware. Compressor motors shall be single-phase PSC or three-phase with internal over load protection.

The coaxial water-to-refrigerant heat exchangers shall be designed for close approach temperatures and be constructed of a convoluted copper (optional cupro-nickel) inner tube and steel outer tube. The brazed plate heat exchanger shall be designed for close approach temperatures and shall be constructed with stainless steel plates. The thermal expansion valve shall provide proper superheat over the entire fluid temperature range with minimal "hunting". The coaxial heat exchangers and refrigerant suction lines shall be insulated to prevent condensation at low liquid temperatures.

Electrical

CXM Control – A microprocessor-based compressor controller shall be provided to monitor and control unit operation. The control shall provide compressor enable, high and low pressure monitoring, field selectable water coil low temperature sensing, and over/under voltage monitoring. The control shall also provide for water valve connection, a test mode, short cycle protection, random start-up, as well as fault LED, fault memory, and intelligent fault retry. The control shall employ quick attach harness assemblies for low voltage connections to the control board to aid in troubleshooting or replacement. An integral terminal block with screw terminals shall be provided on the control for connection to other low voltage controls. The control system microprocessor board shall be specifically designed to protect against building electrical system noise contamination, EMI, and RFI interference.

MPC Control – A programmable controller shall be provided to monitor buffer tank temperature, Domestic Hot Water (DHW) tank temperature, outdoor air temperature, and other inputs to determine when to operate the compressor, pump(s) and hot water valve. The MPC shall be factory-wired to the CXM compressor control module and user interface. MPC programming shall include outdoor temperature reset, warm weather shutdown, cooling enable, heat pump staging, emergency DHW output, pump control, vacation mode, DHW time schedule, advanced diagnostics, user interface communication, and sensor monitoring.

Digital User Interface – A panel-mounted backlit digital user interface shall be factory installed and wired for customization of the MPC programming. Four arrow keys and a select key will be used to control a large dot-matrix style 5 x 5 cm backlit display. The main screen shall display current outdoor and water temperatures, and allow the user to change settings by selecting from one of the menus at the bottom of the screen. A special installer set up mode will allow the technician to change some of the default MPC parameters. The user interface shall include a time schedule for DHW operation, Fahrenheit/Celsius selection, vacation mode for DHW, and other user preference options.

12-point terminal block – A low voltage terminal block with a blue/gray pattern for ease of identification shall be provided to connect thermistors and external wiring. The MPC, user interface, CXM board and other relays/components shall be factory-wired to the terminal block.

Line voltage lugs shall be provided for unit wiring. A circuit breaker protected 75VA transformer shall be employed. Units shall have knockouts for entrance of low and line voltage wiring.

Piping

Source/Load supply and return water connections, as well as Domestic Hot Water supply and return connections shall be 1" FPT (Female Pipe Thread) copper fittings and shall be securely mounted flush to the cabinet allowing for connection to an EPT (External Pipe Thread) fitting without the use of a back-up wrench. All Source water piping shall be insulated to prevent condensation at low liquid temperatures.



CLIMATE MASTER, INC. LIMITED EXPRESS WARRANTY /LIMITATION OF REMEDIES AND LIABILITY (FOR INTERNATIONAL CLASS PRODUCTS)

Disclaimer: It is expressly understood that unless a statement is specifically identified as a warranty, statements made by Climate Master, Inc., a Delaware corporation, U.S.A. ("CM") or its representatives, relating to CM's products, whether oral, written or contained in any sales literature, catalog, brochure or any other agreement or other materials, are not express warranties and do not form a part of the basis of the bargain, but are merely CM's opinion or commendation of CM's products, EXCEPT AS SPECIFICALLY SET FORTH HEREIN AND TO THE FULLEST EXTENT PERMITTED BY APPLICABLE LAW. CM MAKES NO WARRANTY AS TO ANY OF CM'S PRODUCTS, AND CM MAKES NO WARRANTY AGAINST LATENT DEFECTS OR ANY WARRANTY OF MERCHANTABILITY OF THE GOODS OR OF THE FITNESS OF THE GOODS FOR ANY PARTICULAR PURPOSE.

GRANT OF LIMITED EXPRESS WARRANTY

CM warrants CM products purchased and installed outside the United States of America ("U.S.A.") and Canada to be free from material defects in materials and workmanship under normal use and maintenance as follows: (1) All complete air conditioning, heating or heat pump units built or sold by CM for twelve (12) months from date of unit start-up or eighteen (18) months from date of shipment (from CM's factory), whichever comes first; and, (2) Repair and replacement parts, which are not supplied under warranty, for ninety (90) days from date of shipment (from factory).

Warranty parts shall be furnished by CM if ordered through an authorized sales representative of CM ("Representative") within sixty (60) days after the failure of the part. If CM determines that a parts order qualifies for replacement under CM's warranty, such parts shall be shipped freight prepaid to the Representative or the ultimate user, as requested by Representative. All duties, taxes and other fees shall be paid by the ultimate user through the Representative.

If requested by CM, all defective parts shall be returned to CM's factory in Oklahoma City, Oklahoma, U.S.A. Freight and duty prepaid, not later than sixty (60) days after the date of the request. If the defective part is not timely returned or if CM determines the part to not be defective or otherwise not to qualify under CM's Limited Express Warranty, CM shall invoice Customer the costs for the parts furnished, including freight. The warranty on any part repaired or replaced under warranty expires at the end of the original warranty period.

This warranty does not cover and does not apply to: (1) Air filters, fuses, refrigerant, fluids, oil; (2) Products relocated after initial installation; (3) Any portion or component of any system that is not supplied by CM, regardless of the cause of the failure of such portion or component; (4) Products on which the unit identification tags or labels have been removed or detached; (5) Products on which payment by Customer to CM or its distributors or Representatives, or the Customer's seller is in default; (6) Products which have defects or damage which result from improper installation, wiring, electrical imbalance characteristics or maintenance or from parts or components manufactured by others; or are caused by accident, misuse, negligence, abuse, fire, flood, lightning, alteration or misapplication of the product; (7) Products which have defects or damage which result from a contaminated or corrosive air or liquid supply, operation at abnormal temperatures or flow rates, or unauthorized opening of the refrigerant circuit; (8) Mold, fungus or bacterial damages; (9) Products subjected to corrosion or abrasion; (10) Products, parts or components manufactured or supplied by others; (11) Products which have been subjected to misuse, negligence or accidents; (12) Products which have been operated in a manner contrary to CM's printed instructions; (13) Products which have defects, damage or insufficient performance as a result of insufficient or incorrect system design or the improper application, installation, or use of CM's products; or (14) Electricity or fuel costs, or any increases or unrealized savings in same, for any reason.

CM is not responsible for: (1) The cost of any fluids, refrigerant or other system components, or the associated labor to repair or replace the same, which is incurred as a result of a defective part covered by CM's Limited Express Warranty; (2) The cost of labor, refrigerant, materials or service incurred in diagnosis and removal of the defective part or in obtaining and replacing the new or repaired part; (3) Transportation costs of the defective part from the installation site to CM or of the return of any part not covered by CM's Limited Express Warranty; or (4) The costs of normal maintenance.

Limitation: This Limited Express Warranty is given in lieu of all other warranties. If, notwithstanding the disclaimer contained herein, it is determined by a court or other qualified judicial body that other warranties exist, any such warranty, including without limitation any express warranty or any implied warranty of fitness for particular purpose and merchantability, shall be limited to the duration of the Limited Express Warranty. This Limited Express Warranty does not exclude any warranty that is mandatory and that may not be excluded under applicable imperative law.

LIMITATION OF REMEDIES

In the event of a breach of this Limited Express Warranty or any warranty that is mandatory under applicable imperative law, CM will only be obligated at CM's option to either repair the failed part or unit or to furnish a new or rebuilt part or unit in exchange for the part or unit which has failed. If after written notice to CM's factory in Oklahoma City, Oklahoma, U.S.A. of each defect, malfunction or other failure and a reasonable number of attempts by CM to correct the defect, malfunction or other failure and the remedy fails of its essential purpose, CM shall refund the purchase price paid to CM in exchange for the return of the sold good(s). Said refund shall be the maximum liability of CM TO THE FULLEST EXTENT PERMITTED BY APPLICABLE LAW. THIS REMEDY IS THE SOLE AND EXCLUSIVE REMEDY OF THE CUSTOMER AGAINST CM FOR BREACH OF CONTRACT, FOR THE BREACH OF ANY WARRANTY OR FOR CM'S NEGLIGENCE OR IN STRICT LIABILITY.

LIMITATION OF LIABILITY

CM shall have no liability for any damages, if CM's performance is delayed for any reason or is prevented to any extent by any event such as, but not limited to, any war, civil unrest, government restrictions or restraints, strikes, or work stoppages, from the time of the original order of the product to the time of the final installation of the product. CM shall have no liability for any damage, loss or injury to property, including real property, or to persons, including third parties, or to animals, or to the environment, or to the NEXT SENTENCE, CM EXPRESSLY DISCLAIMS AND EXCLUDES ANY LIABILITY FOR LOSS OF PROFITS, LOSS OF BUSINESS OR GOODWILL, CONSEQUENTIAL, INCIDENTAL, SPECIAL, LIQUIDATED, OR PUNITIVE DAMAGES IN CONTRACT, FOR BREACH OF ANY EXPRESS OR IMPLIED WARRANTY, OR IN TORT, WHETHER FOR CM'S NEGLIGENCE OR AS STRICT LIABILITY. Nothing in this Agreement is intended to exclude CM's liability for death, personal injury or fraud.

OBTAINING WARRANTY PERFORMANCE

Normally, the contractor or service organization who installed the products will provide warranty performance for the owner. Should the installer be unavailable, contact any CM recognized Representative. If assistance is required in obtaining warranty performance, write or call:

Climate Master, Inc. • Customer Service • 7300 S.W. 44th Street • Oklahoma City, Oklahoma, U.S.A. 73179 • (405) 745-6000 • FAX: (405) 745-6068

NOTE: Some countries do not allow limitations on how long an implied warranty lasts, or the limitation or exclusions of consequential or incidental damages, so the foregoing exclusions and limitations may not apply to you. This warranty gives you specific legal rights, and you may also have other rights which vary from state to state and country to country.

Please refer to the CM Installation, Operation and Maintenance Manual for operating and maintenance instructions.

Rev.: 10/09



LCO79

Accessories & Warranty

Hot Water Valve

An optional factory-installed 3-way valve wired to the unit controls to provide Domestic Hot Water to an indirect water heater or to a secondary heat exchanger/direct water heater combination. This option provides an additional set of load water connections for ease of installation. Connections are designated for Heating (buffer tank) and Domestic Hot Water (indirect water heater tank).

Internal Source and Load Pumps / Internal Expansion Tanks

Optional Source pump(s), Load pump, and expansion tank(s) shall be factory installed and wired to help lower installation costs and labor. When installed at the factory, pumps are controlled by the MPC.

Variable Speed Floor Pump Connection

An optional relay and line voltage lugs shall be provided for a variable speed radiant floor system pump. Some radiant floor systems utilize a variable speed pump on the floor system, which changes flow based upon the number of zones open or closed. Since the pump has built-in controls, only a power supply is needed.

Cupro-Nickel Heat Exchanger

An optional corrosion resistant CuNi coaxial heat exchanger shall be factory installed in lieu of standard copper construction (Source heat exchanger only).

Standard Warranty:

ClimateMaster THW Series are warranted for twelve (12) months from the date of unit start-up or eighteen (18) months from date of shipment (from CM's factory), whichever comes first. Optional extended warranties are available.

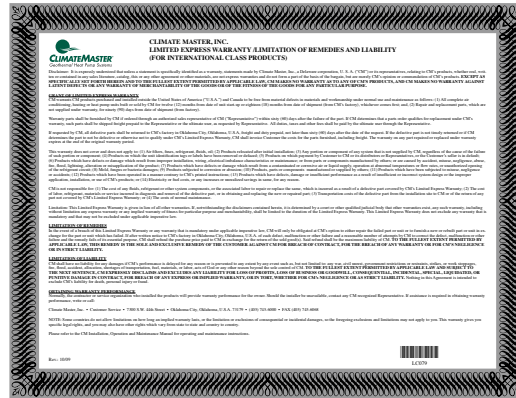

Notes:



7300 S.W. 44th Street
Oklahoma City, OK 73179
Phone: +1-405-745-6000
Fax: +1-405-745-6058
climatemaster.com | cmdealernet.com