

**TRANQUILITY[®] CONSOLE
(TRC) SERIES
SUBMITTAL DATA**

**MODELS TRC 09 - 018
50HZ - HFC-410A**

ENGLISH LANGUAGE/S-I UNITS



Revised: 14 November, 2011



SUBMITTAL DATA - S-I UNITS

Unit Designation: _____

Job Name: _____

Architect: _____

Engineer: _____

Contractor: _____

PERFORMANCE DATA

Cooling Capacity: _____ kW

EER: _____

Heating Capacity: _____ kW

COP: _____

Ambient Air Temp: _____ °C

Entering Water Temp (Clg): _____ °C

Entering Air Temp (Clg): _____ °C

Entering Water Temp (Htg): _____ °C

Entering Air Temp (Htg): _____ °C

Airflow: _____ l/s

Fan Speed or Motor/RPM/Turns: _____

Operating Weight: _____ (kg)

ELECTRICAL DATA

Power Supply: _____ Volts _____ Phase _____ Hz

Minimum Circuit Ampacity: _____

Maximum Overcurrent Protection: _____

ClimateMaster works continually to improve its products. As a result, the design and specifications of each product at the time of order may be changed without notice and may not be as described herein. Please contact ClimateMaster's Customer Service Department at +1-405-745-6000 for specific information on the current design and specifications. Statements and other information contained herein are not express warranties and do not form the basis of any bargain between the parties, but are merely ClimateMaster's opinion or commendation of its products. The latest version of this document is available at climatemaster.com.



EP008

Revised: 14 November, 2011



	*PAGE NUMBER
TRC SERIES NOMENCLATURE	3
PERFORMANCE DATA - AHRI/ASHRAE/ISO 13256-1	4
PERFORMANCE DATA - SELECTION NOTES	5
PERFORMANCE DATA - TRC09	6
PERFORMANCE DATA - TRC12	7
PERFORMANCE DATA - TRC15	8
PERFORMANCE DATA - TRC18	9
ANTIFREEZE CORRECTION TABLE	10
PERFORMANCE DATA - CORRECTION TABLES	10
BLOWER PERFORMANCE & ELECTRICAL DATA	11
PHYSICAL DATA	12
CONSOLE CABINET DIMENSIONS - SIZE 09 - 15 BOTTOM RETURN - LEFT HAND PIPING	13
CONSOLE CABINET DIMENSIONS - SIZE 09 - 15 FRONT RETURN - LEFT HAND PIPING	14
CONSOLE CABINET DIMENSIONS - SIZE 09 - 15 BOTTOM RETURN - RIGHT HAND PIPING	15
CONSOLE CABINET DIMENSIONS - SIZE 09 - 15 FRONT RETURN - RIGHT HAND PIPING	16
CONSOLE CHASSIS DIMENSIONS - SIZE 09 - 15	17
PIPING DETAIL - SIZE 09 - 15	18
CONSOLE CABINET DIMENSIONS - SIZE 18 BOTTOM RETURN - LEFT HAND PIPING	19
CONSOLE CABINET DIMENSIONS - SIZE 18 FRONT RETURN - LEFT HAND PIPING	20
CONSOLE CABINET DIMENSIONS - SIZE 18 BOTTOM RETURN - RIGHT HAND PIPING	21
CONSOLE CABINET DIMENSIONS - SIZE 18 FRONT RETURN - RIGHT HAND PIPING	22
CONSOLE CHASSIS DIMENSIONS - SIZE 18	23
PIPING DETAIL - SIZE 18	24
TRC SERIES WIRING DIAGRAM MATRIX	25
TYPICAL WIRING DIAGRAM MANUAL & AUTO CHANGE OVER TRC UNITS - WITH CXM CONTROLLER	26
TYPICAL WIRING DIAGRAM REMOTE MOUNTED THERMOSTAT TRC UNITS - WITH CXM CONTROLLER	27
TYPICAL WIRING DIAGRAM TRC UNITS WITH CXM & LON CONTROLLER	28
TYPICAL WIRING DIAGRAM TRC UNITS WITH CXM & MPC CONTROLLER	29
TYPICAL WIRING DIAGRAM MANUAL & AUTOCHANGE OVER TRC UNITSM - WITH DXM CONTROLLER	30
TYPICAL WIRING DIAGRAM REMOTE MOUNTED THERMOSTAT TRC UNITS - WITH DXM CONTROLLER	31
TYPICAL WIRING DIAGRAM TRC UNITS WITH DXM & LON CONTROLLER	32
TYPICAL WIRING DIAGRAM TRC UNITS WITH DXM & MPC CONTROLLER	33
TRANQUILITY® CONSOLE (TRC) SERIES ENGINEERING SPECIFICATIONS	34
REVISION HISTORY	40

*Document page number is shown next to part number (e.g. EP008 - 3 = page 3). Since not all pages are typically used in the submittals process, the page number in the lower right corner can still be used (page ____ of ____).

ClimateMaster works continually to improve its products. As a result, the design and specifications of each product at the time of order may be changed without notice and may not be as described herein. Please contact ClimateMaster's Customer Service Department at +1-405-745-6000 for specific information on the current design and specifications. Statements and other information contained herein are not express warranties and do not form the basis of any bargain between the parties, but are merely ClimateMaster's opinion or commendation of its products. The latest version of this document is available at climatemaster.com.

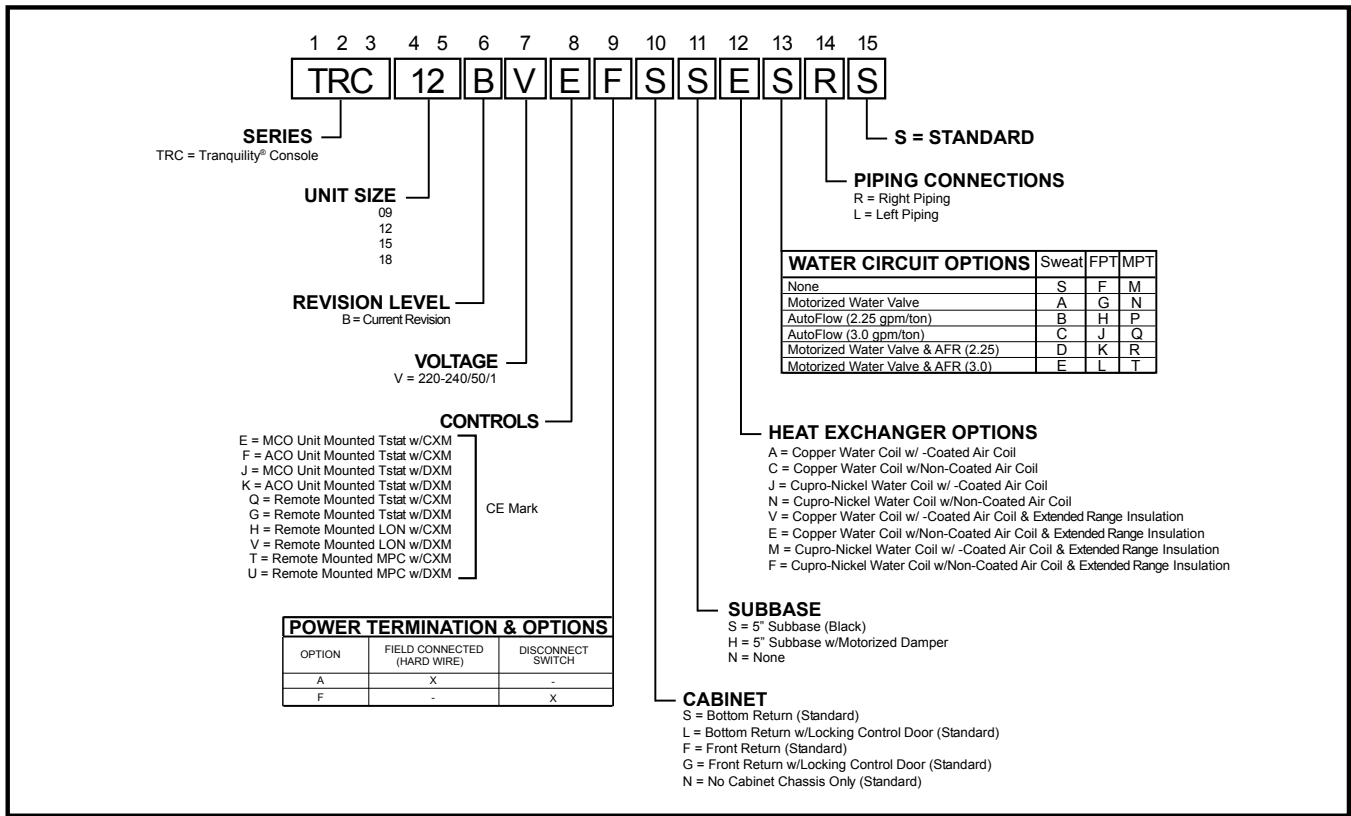

TRC SERIES 50HZ - HFC410A SUBMITTAL DATA ENG/S-I



Performance Data - AHRI/ASHRAE/ISO 13256-1

Model	Water Loop Heat Pump				Ground Water Heat Pump				Ground Loop Heat Pump			
	Cooling 30°C		Heating 20°C		Cooling 15°C		Heating 10°C		Cooling 25°C		Heating 0°C	
	Capacity kW	EER W/W	Capacity kW	COP	Capacity kW	EER W/W	Capacity kW	COP	Capacity kW	EER W/W	Capacity kW	COP
TRC09	2.10	4.3	2.75	5.2	2.53	6.4	2.29	4.3	2.23	4.7	1.70	3.2
TRC12	2.81	3.9	3.49	3.9	3.37	6.5	2.93	3.3	2.99	4.7	2.31	2.5
TRC15	3.33	3.9	4.23	5.0	3.84	6.6	3.53	4.3	3.52	4.7	2.72	3.6
TRC18	3.66	4.8	4.48	4.7	4.18	4.1	3.81	4.2	3.87	4.6	3.05	3.5

Cooling capacities based upon 27°C DB, 19°C WB entering air temperature
 Heating capacities based upon 20°C DB, 15°C WB entering air temperature
 Ground loop heat pump ratings based on 15% methanol antifreeze solution
 All air flow is rated on high speed, Units factory shipped on medium and low motor taps.
 All ratings based upon operation at lower voltage of dual voltage rated models



For operation in the shaded area when water is used in lieu of an antifreeze solution, the LWT (Leaving Water Temperature) must be calculated. Flow must be maintained to a level such that the LWT is maintained above 5°C when the JW3 jumper is not clipped (see example below). This is due to the potential of the refrigerant temperature being as low as 0°C with 5°C LWT, which may lead to a nuisance cutout due to the activation of the Low Temperature Protection. JW3 should never be clipped for standard range equipment or systems without antifreeze.

Example:

At 10°C EWT (Entering Water Temperature) and 0.082 l/s (minimum flow rate), a TRC12 unit has a HE of 2.1 kW. To calculate LWT, rearrange the formula for HE as follows:

$$HE = TD \times \text{Flow} \times 4.18$$

where HE = Heat of Extraction (kW); TD = temperature difference (EWT - LWT); and

Flow = Water Flow Rate in l/s

$$TD = HE / (\text{l/s} \times 4.18)$$

$$TD = 2.1 / (0.082 \times 4.18)$$

$$TD = 6.1^\circ\text{C}$$

$$LWT = EWT - TD$$

$$LWT = 10 - 6.1 = 3.9^\circ\text{C}$$

In this example, operating at minimum flow rate when the EWT is 10°C could cause a nuisance cutout. Therefore, the flow rate should be increased to maintain a LWT of at least 5°C. This example is typical of open loop systems with EWT at or below 10°C. The middle flow rate (0.126 l/s) provides a TD of 4.0°C, which maintains a LWT of 6°C, well above the minimum.

HEATING - EAT 20 °C					
TRC W/W	HC kW	Power kW	HE kW	LAT °C	COP W/W
	1.90	0.65	1.3	28.3	1.94
7.30	2.14	0.66	1.5	29.4	2.24
6.96	2.24	0.67	1.6	29.8	2.37
6.69	2.29	0.67	1.6	30.0	2.43
7.10	2.48	0.68	1.8	30.9	2.66
7.32	2.60	0.68	1.9	31.4	2.80
7.30	2.65	0.69	2.0	31.6	2.86
6.40	2.81	0.70	2.1	32.3	3.04
6.94	2.94	0.70	2.2	32.9	3.18
7.12	3.00	0.71	2.3	33.1	3.25
7.3	3.12	0.71	2.4	33.6	3.38
	3.25	0.72	2.5	34.3	3.53
	3.32	0.72	2.6	34.5	3.6
		0.73	2.7	34.8	3.7



151 l/s Nominal Airflow Heating, 142 l/s Nominal Airflow Cooling

EWT °C	Flow		WPD kPa	Cooling - EAT 27/19 °C						Heating - EAT 20 °C				
	l/s	l/m		TC kW	SC kW	S/T Ratio	Power KW	HR kW	EER W/W	HC kW	Power kW	HE kW	LAT °C	COP W/W
-5	0.139	8.33	34.52	Operation not Recommended						1.33	0.53	0.8	29.2	2.52
0	0.069	4.16	11.05	2.85	2.05	0.72	0.33	3.2	8.7	1.61	0.54	1.1	29.4	2.98
	0.101	6.06	17.95	2.90	2.04	0.70	0.30	3.2	9.6	1.69	0.54	1.1	30.0	3.11
	0.139	8.33	31.07	2.93	2.04	0.70	0.29	3.2	10.2	1.75	0.55	1.2	30.3	3.19
5	0.069	4.16	9.67	2.75	2.07	0.75	0.37	3.1	7.5	1.96	0.56	1.4	31.4	3.52
	0.101	6.06	15.88	2.81	2.06	0.73	0.34	3.2	8.2	2.06	0.56	1.5	32.0	3.68
	0.139	8.33	29.00	2.85	2.05	0.72	0.33	3.2	8.7	2.12	0.56	1.6	32.5	3.77
10	0.069	4.16	8.29	2.65	2.08	0.79	0.41	3.1	6.5	2.27	0.57	1.7	33.3	4.02
	0.101	6.06	15.19	2.71	2.07	0.76	0.38	3.1	7.1	2.38	0.57	1.8	33.9	4.18
	0.139	8.33	26.24	2.75	2.07	0.75	0.37	3.1	7.5	2.45	0.57	1.9	34.1	4.28
15	0.069	4.16	7.60	2.52	2.07	0.82	0.45	3.0	5.6	2.56	0.57	2.0	35.0	4.46
	0.101	6.06	14.50	2.60	2.08	0.80	0.43	3.0	6.1	2.67	0.58	2.1	35.6	4.63
	0.139	8.33	25.55	2.64	2.08	0.79	0.41	3.1	6.4	2.74	0.58	2.2	36.0	4.74
20	0.069	4.16	6.90	2.38	2.04	0.86	0.50	2.9	4.8	2.82	0.58	2.2	36.4	4.86
	0.101	6.06	13.81	2.46	2.06	0.84	0.47	2.9	5.2	2.93	0.58	2.3	37.1	5.04
	0.139	8.33	24.17	2.51	2.07	0.82	0.45	3.0	5.5	3.00	0.58	2.4	37.5	5.15
25	0.069	4.16	6.90	2.22	1.97	0.89	0.55	2.8	4.1	3.05	0.58	2.5	37.8	5.23
	0.101	6.06	13.12	2.31	2.01	0.87	0.52	2.8	4.4	3.16	0.58	2.6	38.4	5.40
	0.139	8.33	22.10	2.36	2.03	0.86	0.50	2.9	4.7	3.23	0.59	2.6	38.8	5.51
30	0.069	4.16	6.90	2.12	1.91	0.90	0.57	2.7	3.7	3.15	0.59	2.6	38.4	5.40
	0.101	6.06	13.12	2.22	1.97	0.89	0.55	2.8	4.1	3.26	0.59	2.7	39.0	5.56
	0.139	8.33	21.40	2.28	1.99	0.88	0.51	2.8	4.3	3.33	0.59	2.7	39.4	5.67
35	0.069	4.16	6.21	2.03	1.86	0.91	0.60	2.6	3.4	Operation not Recommended				
	0.101	6.06	13.12	2.13	1.92	0.90	0.57	2.7	3.7					
	0.139	8.33	20.71	2.19	1.95	0.89	0.55	2.7	4.0					
40	0.069	4.16	6.21	1.82	1.70	0.93	0.66	2.5	2.8					
	0.101	6.06	12.43	1.93	1.78	0.92	0.63	2.6	3.1					
	0.139	8.33	20.02	1.99	1.83	0.92	0.61	2.6	3.3					
45	0.069	4.16	6.21	1.59	1.50	0.94	0.72	2.3	2.2					
	0.101	6.06	12.43	1.70	1.60	0.94	0.69	2.4	2.5					
	0.139	8.33	20.02	1.77	1.66	0.94	0.67	2.4	2.6					

Interpolation is permissible; extrapolation is not.

All entering air conditions are 27°C DB and 19°C WB in cooling and 20°C DB in heating.

AHRI/ISO certified conditions are 27°C DB and 19°C WB in cooling and 20°C DB in heating.

Table does not reflect fan or pump power corrections for AHRI/ISO conditions.

All performance data is based upon the lower voltage of dual voltage rated units.

Performance stated is at the rated power supply; performance may vary as the power supply varies from the rated.

Operation below 4°C EWT is based upon a 15% methanol antifreeze solution.

Operation below 16°C EWT requires optional insulated water/refrigerant circuit.

See performance correction tables for operating conditions other than those listed above.

Gray shaded area refers to calculations required to determine if heating water flow is sufficient for non-antifreeze systems.

TRC SERIES 50HZ - HFC410A SUBMITTAL DATA ENG/S-I



Performance Data - TRC12

184 l/s Nominal Airflow Heating, 175 l/s Nominal Airflow Cooling

EWT °C	FLOW			COOLING - EAT 27/19 °C						HEATING - EAT 20 °C				
	l/s	l/m	WPD kPa	TC kW	SC kW	S/T Ratio	Power kW	HR kW	EER W/W	HC kW	Power kW	HE kW	LAT °C	COP W/W
-5	0.164	9.84	43.4	Operation not Recommended						1.90	0.65	1.3	28.3	1.94
0	0.082	4.92	9.7	3.32	2.44	0.73	0.45	3.8	7.30	2.14	0.66	1.5	29.4	2.24
	0.126	7.57	27.6	3.19	2.33	0.73	0.46	3.6	6.96	2.24	0.67	1.6	29.8	2.37
	0.164	9.84	39.3	3.11	2.27	0.73	0.47	3.6	6.69	2.29	0.67	1.6	30.0	2.43
5	0.082	4.92	9.0	3.38	2.51	0.74	0.48	3.9	7.10	2.48	0.68	1.8	30.9	2.66
	0.126	7.57	24.1	3.35	2.47	0.74	0.46	3.8	7.32	2.60	0.68	1.9	31.4	2.80
	0.164	9.84	36.5	3.32	2.43	0.73	0.45	3.8	7.30	2.65	0.69	2.0	31.6	2.86
10	0.082	4.92	9.0	3.34	2.52	0.76	0.52	3.9	6.40	2.81	0.70	2.1	32.3	3.04
	0.126	7.57	20.7	3.38	2.52	0.75	0.49	3.9	6.94	2.94	0.70	2.2	32.9	3.18
	0.164	9.84	33.1	3.38	2.51	0.74	0.48	3.9	7.12	3.00	0.71	2.3	33.1	3.25
15	0.082	4.92	7.6	3.21	2.48	0.77	0.58	3.8	5.53	3.12	0.71	2.4	33.6	3.38
	0.126	7.57	18.6	3.31	2.51	0.76	0.54	3.8	6.17	3.25	0.72	2.5	34.3	3.53
	0.164	9.84	30.3	3.34	2.52	0.75	0.52	3.9	6.43	3.32	0.72	2.6	34.5	3.59
20	0.082	4.92	6.9	3.04	2.42	0.79	0.65	3.7	4.67	3.40	0.73	2.7	34.9	3.69
	0.126	7.57	17.2	3.17	2.47	0.78	0.60	3.8	5.27	3.54	0.73	2.8	35.5	3.84
	0.164	9.84	29.0	3.22	2.48	0.77	0.58	3.8	5.55	3.61	0.74	2.9	35.8	3.90
25	0.082	4.92	6.2	2.84	2.33	0.82	0.73	3.6	3.90	3.67	0.74	2.9	36.1	3.96
	0.126	7.57	15.9	2.98	2.39	0.80	0.67	3.7	4.41	3.80	0.74	3.1	36.7	4.11
	0.164	9.84	26.9	3.04	2.42	0.79	0.65	3.7	4.66	3.86	0.75	3.1	36.9	4.17
30	0.082	4.92	5.5	2.62	2.24	0.86	0.80	3.4	3.26	3.90	0.75	3.2	37.1	4.22
	0.126	7.57	15.2	2.76	2.30	0.83	0.75	3.5	3.67	4.03	0.75	3.3	37.6	4.36
	0.164	9.84	25.5	2.83	2.33	0.82	0.73	3.6	3.87	4.08	0.75	3.3	37.9	4.42
35	0.082	4.92	4.8	2.41	2.16	0.90	0.88	3.3	2.74	Operation not Recommended				
	0.126	7.57	14.5	2.54	2.21	0.87	0.83	3.4	3.05					
	0.164	9.84	24.8	2.60	2.24	0.86	0.81	3.4	3.21					
40	0.082	4.92	4.8	2.22	2.09	0.94	0.95	3.2	2.34					
	0.126	7.57	13.8	2.33	2.13	0.91	0.91	3.2	2.57					
	0.164	9.84	24.1	2.39	2.15	0.90	0.89	3.3	2.68					
45	0.082	4.92	4.8	2.07	2.07	1.00	1.01	3.1	2.05					
	0.126	7.57	13.8	2.15	2.08	0.97	0.98	3.1	2.21					
	0.164	9.84	24.1	2.19	2.09	0.95	0.96	3.2	2.29					

Interpolation is permissible; extrapolation is not.

All entering air conditions are 27°C DB and 19°C WB in cooling and 20°C DB in heating.

AHRI/ISO certified conditions are 27°C DB and 19°C WB in cooling and 20°C DB in heating.

Table does not reflect fan or pump power corrections for AHRI/ISO conditions.

All performance data is based upon the lower voltage of dual voltage rated units.

Performance stated is at the rated power supply; performance may vary as the power supply varies from the rated.

Operation below 4°C EWT is based upon a 15% methanol antifreeze solution.

Operation below 16°C EWT requires optional insulated water/refrigerant circuit.

See performance correction tables for operating conditions other than those listed above.

Gray shaded area refers to calculations required to determine if heating water flow is sufficient for non-antifreeze systems.

TRC SERIES 50HZ - HFC410A SUBMITTAL DATA ENG/S-I



Performance Data - TRC15

189 l/s Nominal Airflow Cooling, 198 l/s Nominal Airflow Heating

EWT °C	Flow			Cooling - EAT 27/19 °C						Heating - EAT 20 °C				
	l/s	l/m	WPD kPa	TC kW	SC kW	S/T Ratio	Power kW	HR kW	EER W/W	HC kW	Power kW	HE kW	LAT °C	COP W/W
-5	0.189	11.36	22.8	Operation not Recommended						2.25	0.71	1.5	29.6	3.15
0	0.095	5.68	4.8	4.26	3.20	0.75	0.48	4.74	8.95	2.48	0.73	1.7	30.6	3.39
	0.145	8.71	12.4	4.30	3.22	0.75	0.42	4.72	10.14	2.58	0.74	1.8	31.0	3.50
	0.189	11.36	20.7	4.29	3.23	0.75	0.40	4.69	10.79	2.64	0.74	1.9	31.3	3.56
5	0.095	5.68	4.1	4.15	3.15	0.76	0.54	4.69	7.63	2.83	0.75	2.1	32.1	3.76
	0.145	8.71	11.0	4.24	3.19	0.75	0.49	4.73	8.63	2.96	0.76	2.2	32.6	3.88
	0.189	11.36	19.3	4.27	3.21	0.75	0.47	4.74	9.18	3.02	0.77	2.3	32.9	3.95
10	0.095	5.68	3.8	3.98	3.08	0.77	0.61	4.59	6.49	3.18	0.77	2.4	33.6	4.11
	0.145	8.71	9.7	4.11	3.14	0.76	0.56	4.67	7.34	3.33	0.78	2.5	34.2	4.24
	0.189	11.36	18.6	4.17	3.16	0.76	0.53	4.70	7.81	3.40	0.79	2.6	34.5	4.32
15	0.095	5.68	3.4	3.76	3.00	0.80	0.68	4.45	5.51	3.53	0.80	2.7	35.1	4.44
	0.145	8.71	9.0	3.92	3.06	0.78	0.63	4.56	6.22	3.69	0.80	2.9	35.8	4.59
	0.189	11.36	17.2	4.00	3.09	0.77	0.60	4.60	6.62	3.78	0.81	3.0	36.1	4.67
20	0.095	5.68	2.8	3.53	2.90	0.82	0.76	4.28	4.65	3.87	0.81	3.1	36.5	4.76
	0.145	8.71	8.3	3.70	2.97	0.80	0.70	4.40	5.25	4.05	0.82	3.2	37.3	4.93
	0.189	11.36	15.9	3.78	3.00	0.79	0.68	4.46	5.59	4.15	0.83	3.3	37.7	5.02
25	0.095	5.68	2.8	3.27	2.79	0.85	0.84	4.11	3.90	4.22	0.83	3.4	38.0	5.07
	0.145	8.71	8.3	3.45	2.87	0.83	0.78	4.23	4.40	4.42	0.84	3.6	38.9	5.26
	0.189	11.36	15.2	3.54	2.90	0.82	0.75	4.29	4.69	4.52	0.85	3.7	39.3	5.35
30	0.095	5.68	2.8	3.01	2.68	0.89	0.92	3.93	3.26	4.56	0.85	3.7	39.5	5.38
	0.145	8.71	7.6	3.18	2.75	0.87	0.87	4.05	3.67	4.78	0.86	3.9	40.4	5.58
	0.189	11.36	14.5	3.27	2.79	0.85	0.84	4.11	3.90	4.90	0.86	4.0	40.9	5.69
35	0.095	5.68	2.8	2.76	2.57	0.93	1.02	3.77	2.71	Operation not Recommended				
	0.145	8.71	7.6	2.92	2.64	0.91	0.96	3.87	3.04					
	0.189	11.36	13.8	3.00	2.68	0.89	0.93	3.93	3.23					
40	0.095	5.68	2.8	2.52	2.47	0.98	1.12	3.64	2.25					
	0.145	8.71	7.6	2.66	2.53	0.95	1.06	3.72	2.52					
	0.189	11.36	13.8	2.74	2.56	0.94	1.03	3.76	2.67					
45	0.095	5.68	2.8	2.31	2.39	1.03	1.23	3.55	1.87					
	0.145	8.71	7.6	2.43	2.43	1.00	1.17	3.59	2.08					
	0.189	11.36	13.8	2.49	2.46	0.99	1.13	3.63	2.20					

Interpolation is permissible; extrapolation is not.

All entering air conditions are 27°C DB and 19°C WB in cooling and 20°C DB in heating.

AHRI/ISO certified conditions are 27°C DB and 19°C WB in cooling and 20°C DB in heating.

Table does not reflect fan or pump power corrections for AHRI/ISO conditions.

All performance data is based upon the lower voltage of dual voltage rated units.

Performance stated is at the rated power supply; performance may vary as the power supply varies from the rated.

Operation below 4°C EWT is based upon a 15% methanol antifreeze solution.

Operation below 16°C EWT requires optional insulated water/refrigerant circuit.

See performance correction tables for operating conditions other than those listed above.

Gray shaded area refers to calculations required to determine if heating water flow is sufficient for non-antifreeze systems.

TRC SERIES 50HZ - HFC410A SUBMITTAL DATA ENG/S-I



Performance Data - TRC18

269 l/s Nominal Airflow Heating, 250 l/s Nominal Airflow Cooling

EWT °C	Flow		WPD kPa	Cooling - EAT 27/19 °C						Heating - EAT 20 °C				
	l/s	l/m		TC kW	SC kW	S/T Ratio	Power kW	HR kW	EER W/W	HC kW	Power kW	HE kW	LAT °C	COP W/W
-5	0.215	12.87	32.4	Operation not Recommended						2.49	0.79	1.7	28.4	3.14
0	0.120	7.19	9.0	4.31	3.33	0.77	0.80	5.1	5.36	2.71	0.80	1.9	29.1	3.36
	0.145	8.71	15.2	4.32	3.34	0.77	0.77	5.1	5.59	2.77	0.81	2.0	29.3	3.42
	0.215	12.87	30.3	4.32	3.37	0.78	0.73	5.1	5.94	2.87	0.82	2.1	29.7	3.51
5	0.120	7.19	8.3	4.24	3.28	0.77	0.89	5.1	4.76	3.09	0.84	2.3	30.4	3.69
	0.145	8.71	13.8	4.27	3.30	0.77	0.86	5.1	4.99	3.16	0.84	2.3	30.7	3.76
	0.215	12.87	28.3	4.31	3.32	0.77	0.81	5.1	5.35	3.29	0.85	2.4	31.1	3.86
10	0.120	7.19	6.9	4.13	3.22	0.78	0.99	5.1	4.18	3.50	0.87	2.6	31.8	4.00
	0.145	8.71	12.4	4.18	3.24	0.78	0.95	5.1	4.40	3.59	0.88	2.7	32.1	4.07
	0.215	12.87	26.2	4.24	3.28	0.77	0.89	5.1	4.75	3.75	0.90	2.9	32.6	4.17
15	0.120	7.19	6.2	3.98	3.16	0.79	1.09	5.1	3.64	3.92	0.91	3.0	33.2	4.28
	0.145	8.71	11.0	4.04	3.18	0.79	1.05	5.1	3.84	4.03	0.93	3.1	33.6	4.35
	0.215	12.87	24.8	4.13	3.22	0.78	0.99	5.1	4.17	4.21	0.94	3.3	34.2	4.47
20	0.120	7.19	5.5	3.80	3.09	0.81	1.21	5.0	3.15	4.34	0.95	3.4	34.6	4.54
	0.145	8.71	10.3	3.87	3.11	0.80	1.16	5.0	3.33	4.46	0.97	3.5	35.0	4.62
	0.215	12.87	23.4	3.98	3.16	0.79	1.10	5.1	3.62	4.66	0.98	3.7	35.7	4.74
25	0.120	7.19	4.8	3.60	3.00	0.83	1.33	4.9	2.70	4.75	0.99	3.8	36.0	4.79
	0.145	8.71	9.7	3.67	3.03	0.83	1.28	5.0	2.86	4.87	1.00	3.9	36.4	4.87
	0.215	12.87	22.1	3.79	3.08	0.81	1.21	5.0	3.12	5.07	1.01	4.1	37.1	5.00
30	0.120	7.19	4.1	3.37	2.89	0.86	1.46	4.8	2.30	5.12	1.02	4.1	37.3	5.04
	0.145	8.71	9.0	3.45	2.93	0.85	1.41	4.9	2.44	5.25	1.02	4.2	37.7	5.13
	0.215	12.87	20.7	3.58	2.99	0.84	1.34	4.9	2.67	5.44	1.03	4.4	38.3	5.28
35	0.120	7.19	4.1	3.12	2.77	0.89	1.60	4.7	1.94	Operation not Recommended				
	0.145	8.71	9.0	3.21	2.82	0.88	1.55	4.8	2.06					
	0.215	12.87	20.0	3.34	2.88	0.86	1.48	4.8	2.26					
40	0.120	7.19	3.4	2.86	2.63	0.92	1.76	4.6	1.63					
	0.145	8.71	8.3	2.95	2.68	0.91	1.70	4.7	1.73					
	0.215	12.87	19.3	3.08	2.76	0.89	1.63	4.7	1.90					
45	0.120	7.19	3.4	2.59	2.47	0.95	1.92	4.5	1.35					
	0.145	8.71	8.3	2.68	2.52	0.94	1.86	4.5	1.44					
	0.215	12.87	19.3	2.82	2.61	0.93	1.78	4.6	1.58					

Interpolation is permissible; extrapolation is not.

All entering air conditions are 27°C DB and 19°C WB in cooling and 20°C DB in heating.

AHRI/ISO certified conditions are 27°C DB and 19°C WB in cooling and 20°C DB in heating.

Table does not reflect fan or pump power corrections for AHRI/ISO conditions.

All performance data is based upon the lower voltage of dual voltage rated units.

Performance stated is at the rated power supply; performance may vary as the power supply varies from the rated.

Operation below 4°C EWT is based upon a 15% methanol antifreeze solution.

Operation below 16°C EWT requires optional insulated water/refrigerant circuit.

See performance correction tables for operating conditions other than those listed above.

Gray shaded area refers to calculations required to determine if heating water flow is sufficient for non-antifreeze systems.



Air Flow Correction Table

Airflow % of Nominal	Heating			Cooling			
	Heating Capacity	Power kW	Heat of Extraction	Total Capacity	Sensible Capacity	Power kW	Heat of Rejection
75	0.970	1.070	0.950	0.950	0.910	0.970	0.950
83	0.983	1.042	0.968	0.964	0.953	0.981	0.967
89	0.990	1.026	0.981	0.974	0.974	0.987	0.977
94	0.995	1.012	0.991	0.987	0.990	0.993	0.988
100	1.000	1.000	1.000	1.000	1.000	1.000	1.000
106	1.004	0.991	1.007	1.015	1.002	1.008	1.014
111	1.006	0.985	1.011	1.031	0.996	1.016	1.028

Entering Air Correction Table

Heating			
Entering Air DB °C	Heating Capacity	Power kW	Heat of Extraction
15	1.030	0.910	1.060
17	1.019	0.949	1.037
20	1.000	1.000	1.000
22	0.987	1.032	0.975
24	0.973	1.065	0.950
26	0.960	1.109	0.931

Cooling										
Entering Air WB °C	Total Capacity kW	Sens Clg Cap Multiplier-EAT db °C							Power kW	Heat of Rejection
		21	23	25	27	29.5	32	35		
15	0.900	0.7	0.9	1.0	*	*	*	*	1.0000	0.9000
17	0.961	0.6801	0.8495	0.9996	*	*	*	*	1.0014	0.9631
19	1.000	0.5261	0.7376	0.9140	1.0000	1.1602	*	*	1.0000	1.0000
21	1.050		0.5663	0.7679	0.8461	1.0202	1.1870	*	0.9999	1.0408
23	1.100			0.5000	0.5000	0.7000	0.9000	1.1000	1.0000	1.1000
25	1.176			0.5250	0.5910	0.7980	1.0040	1.1780	1.0470	1.1490

* = Sensible capacity equals total capacity
 AHRI/ISO/ASHRAE 13256-1 uses entering air conditions of Cooling - 27.0°C DB/19.0°C WB, 1 and Heating - 20.0°C DB/15.0°C WB entering air temperature

Antifreeze Correction Table

Antifreeze Type	Antifreeze %	Cooling			Heating		WPD Corr. Fct. EWT -1°C	
		EWT 32°C			EWT -1°C			
		Total Cap	Sens Cap	Power	Htg Cap	Power		
Water	0	1.000	1.000	1.000	1.000	1.000	1.000	
	Propylene Glycol	5	0.995	0.995	1.003	0.989	0.997	1.070
		15	0.986	0.986	1.009	0.968	0.990	1.210
Methanol	25	0.978	0.978	1.014	0.947	0.983	1.360	
	5	0.997	0.997	1.002	0.989	0.997	1.070	
	15	0.990	0.990	1.007	0.968	0.990	1.160	
Ethanol	25	0.982	0.982	1.012	0.949	0.984	1.220	
	5	0.998	0.998	1.002	0.981	0.994	1.140	
	15	0.994	0.994	1.005	0.944	0.983	1.300	
Ethylene Glycol	25	0.986	0.986	1.009	0.917	0.974	1.360	
	5	0.998	0.998	1.002	0.993	0.998	1.040	
	15	0.994	0.994	1.004	0.980	0.994	1.120	
	25	0.988	0.988	1.008	0.966	0.990	1.200	

ClimateMaster works continually to improve its products. As a result, the design and specifications of each product at the time of order may be changed without notice and may not be as described herein. Please contact ClimateMaster's Customer Service Department at +1-405-745-6000 for specific information on the current design and specifications. Statements and other information contained herein are not express warranties and do not form the basis of any bargain between the parties, but are merely ClimateMaster's opinion or commendation of its products. The latest version of this document is available at climatemaster.com.



Blower Performance

Model	Rated Airflow HTG l/s	Rated Airflow CLG l/s	Airflow l/s		
			High	Medium	Low
			Speed	Speed	Speed
TRC09	151	142	146	127	113
TRC12	184	175	175	142	118
TRC15	189	198	189	170	149
TRC18	269	250	250	212	179

Notes:

All airflow is rated at the lowest voltage if unit is dual voltage rated. I.e. 220 volts for 220/240 volt rated units.

All units AHRI/ISO/ASHRAE 13256-1 rated on High fan speed.

Units shipped on Medium and Low taps.

All units are designed and rated for zero external static pressure (non ducted) application.

Electrical Data

Model	Voltage Code	Voltage	Min/Max Voltage	Compressor			Fan Motor FLA	Total Unit FLA	Min Circ Amp	Max Fuse/
				QTY	RLA	LRA				
TRC09	T	220-240/50/1	198-264	1	3.2	17	0.4	3.6	4.4	15.0
TRC12	T	220-240/50/1	198-264	1	4.0	19	0.4	4.4	5.4	15.0
TRC15	T	220-240/50/1	198-264	1	4.7	23	0.6	5.3	6.5	15.0
TRC18	T	220-240/50/1	198-264	1	5.6	25	0.6	6.2	7.6	15.0



Model	09	12	15	18
Compressor (1 Each)	Rotary			
Factory Charge HFC-410A [kg]	0.737	0.822	0.936	0.850
PSC Fan Motor & Blower (3 Speeds)				
Fan Motor W	37	62	93	93
Blower Wheel Size (dia x w) - [mm] - Qty 2	133 x 159			
Water Connection Size				
O.D. Sweat [mm]	12.7		19.1	
Optional FPT Fittings (in)	1/2		3/4	
Optional MPT Fittings (in)	1/2		3/4	
Condensate Connection Size				
I.D. Vinyl Hose [mm]	15.9			
Air Coil Size				
Dimensions (h x w) - [cm]	20.3 x 66.0	25.4 x 66.0		25.4 x 81.2
Filter Size				
Bottom Return [cm]	25.4 x 76.2 x 2.5		25.4 x 91.4 x 2.5	
Front Return [cm]	17.8 x 74.9 x 0.32		17.8 x 80.0 x .32	
Cabinet Size				
Bottom Return (Std. 5" Base) (W x H x D) - [cm]	121.9 x 66.0 x 30.5		137.2 x 66.0 x 30.5	
Front Return (No Subbase) (W x H x D) - [cm]	121.9 x 53.3 x 30.5		137.2 x 53.3 x 30.5	
Cabinet Size				
Weight - Operating [kg]	79	82	86.2	99.8
Weight - Packaged [kg]	83.9	86	90.8	105.2

All units have rubber grommet compressor mountings and TXV expansion devices.

Unit Maximum Water Working Pressure	
Options	Max Pressure kPa
Base Unit	2,068
Internal Secondary Pump (ISP)	999
Internal Motorized Water Valve (MWV)	2,068
Internal Auto Flow Valve	2,068

Use the lowest maximum pressure rating when multiple options are combined.



Left Hand Bottom Return

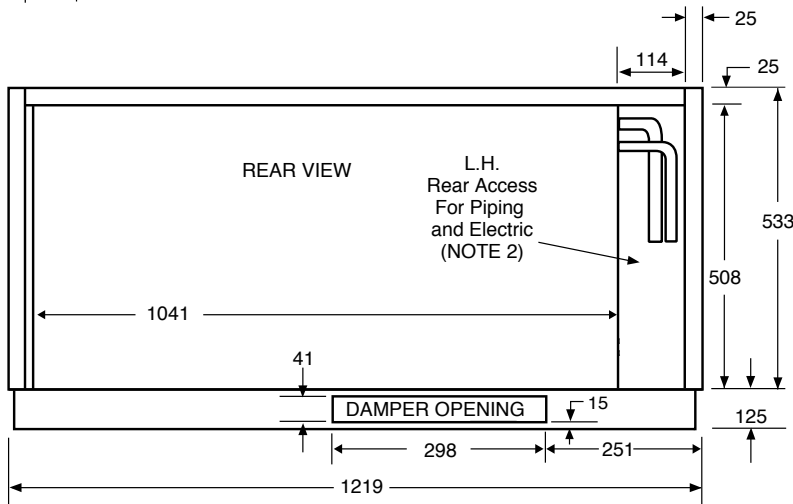
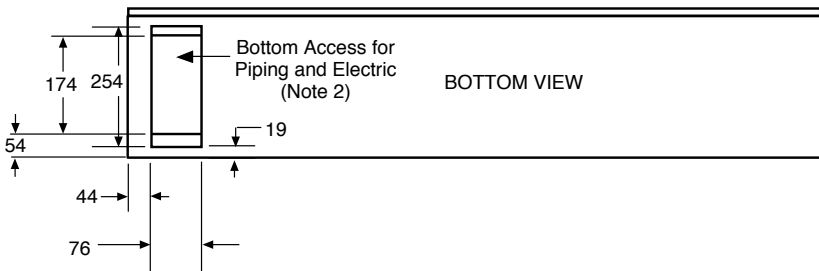
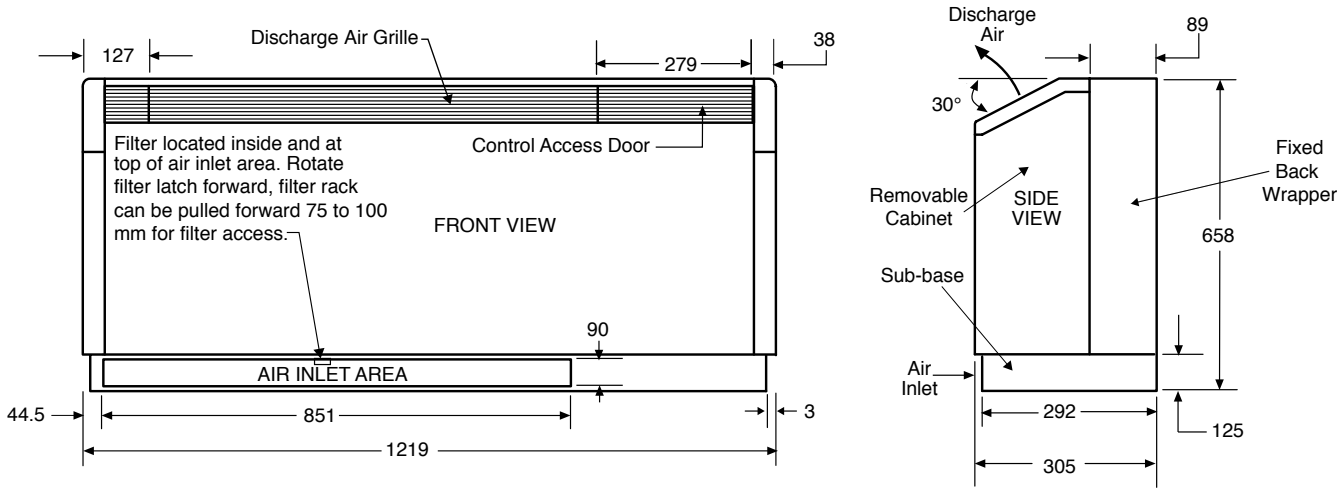

- Notes:**
1. All Dimensions are in mm.
 2. Access is reduced if optional disconnect box is selected.
 3. Optional autoflow regulator, motorized water valve, and disconnect box are not shown.
 4. Filter is 25 mm thick fiberglass throwaway.



Left Hand Front Return

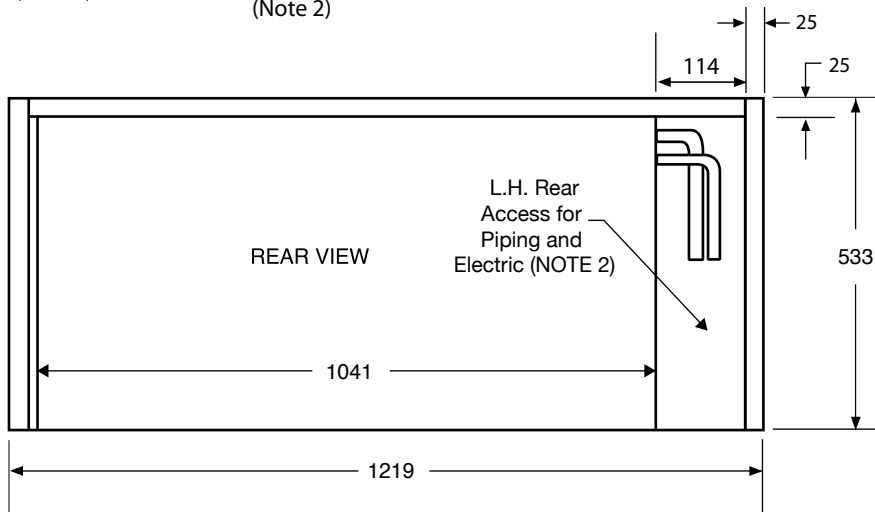
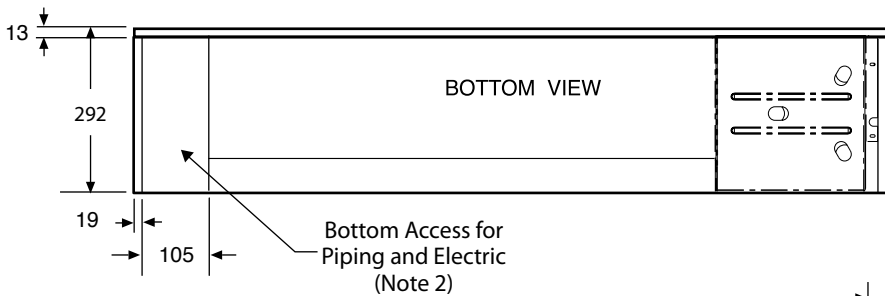
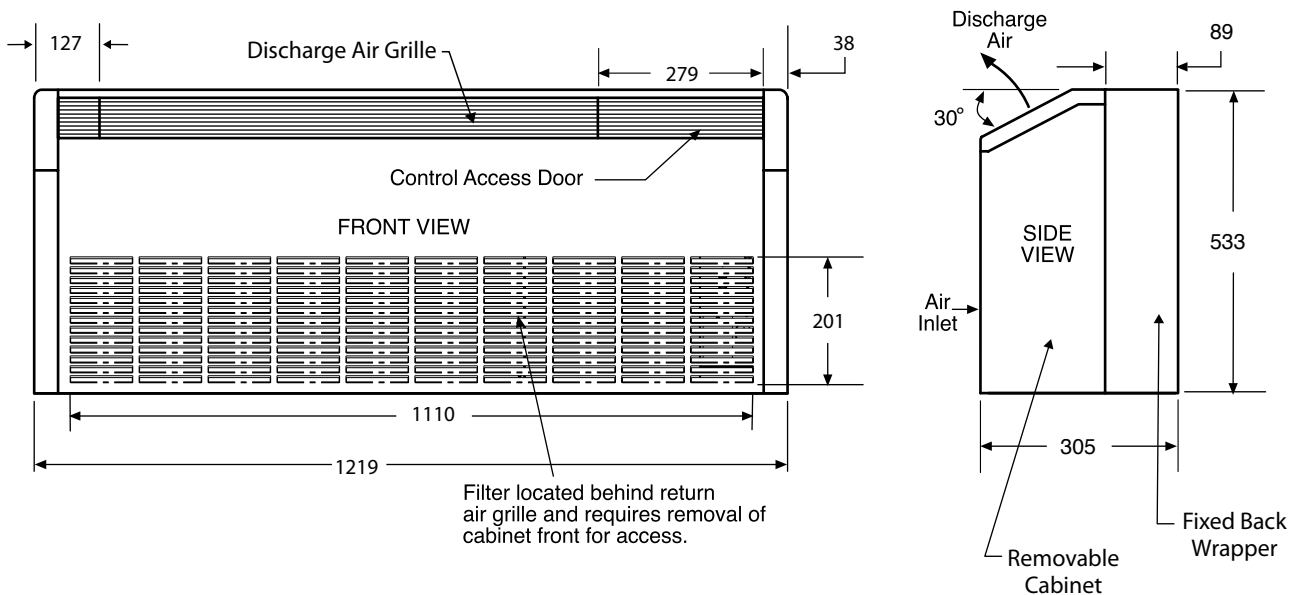

Notes:

1. All Dimensions are in mm.
2. Access is reduced if optional disconnect box is selected.
3. Optional autoflow regulator, motorized water valve, and disconnect box are not shown.
4. Filter is a cleanable polypropylene mesh.



Console Cabinet Dimensions - Size 09 - 15
Bottom Return - Right Hand Piping

Right Hand Bottom Return

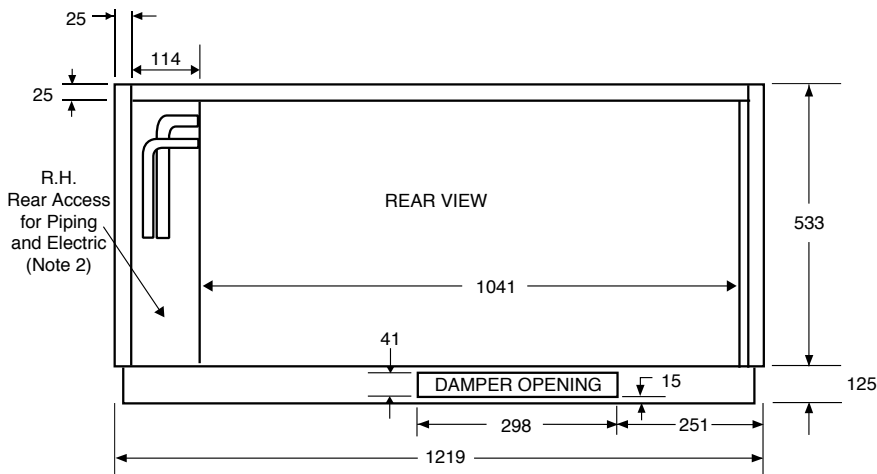
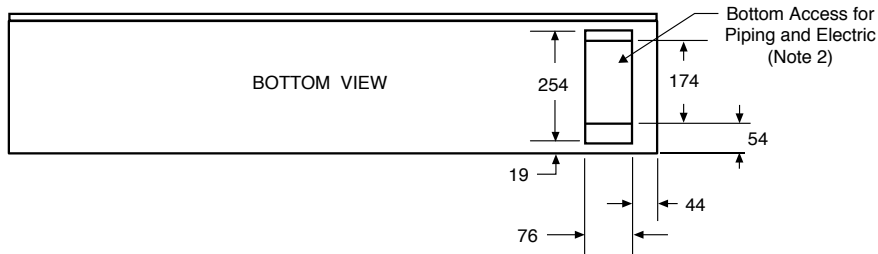
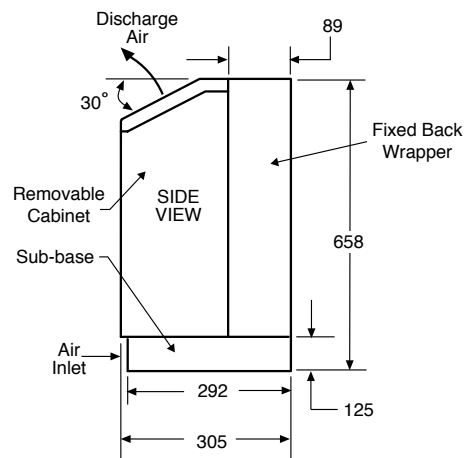
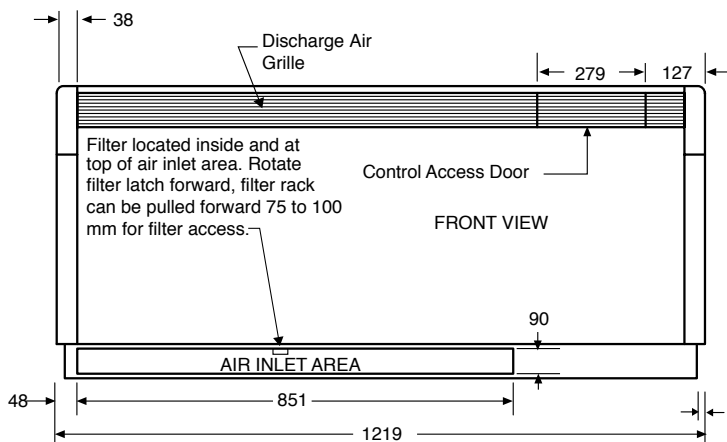

Notes:

1. All Dimensions are in mm.
2. Access is reduced if optional disconnect box is selected.
3. Optional autoflow regulator, motorized water valve, and disconnect box are not shown.
4. Filter is 25 mm thick fiberglass throwaway.



Console Cabinet Dimensions - Size 09 - 15
Front Return - Right Hand Piping

Right Hand Front Return

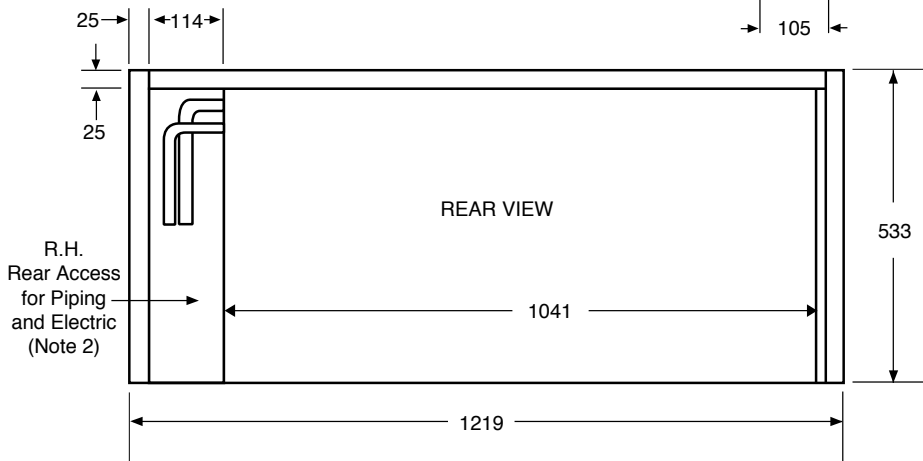
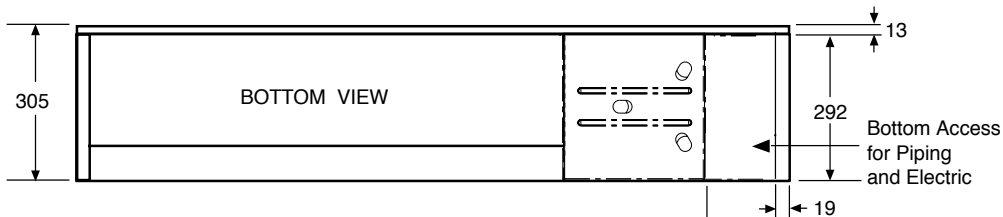
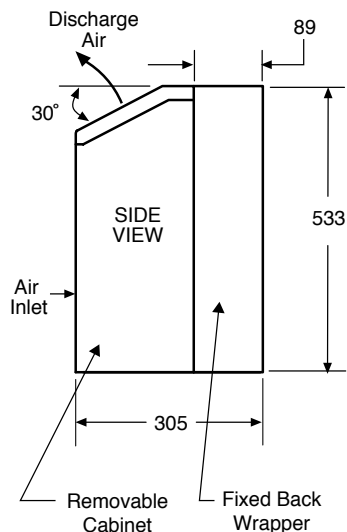
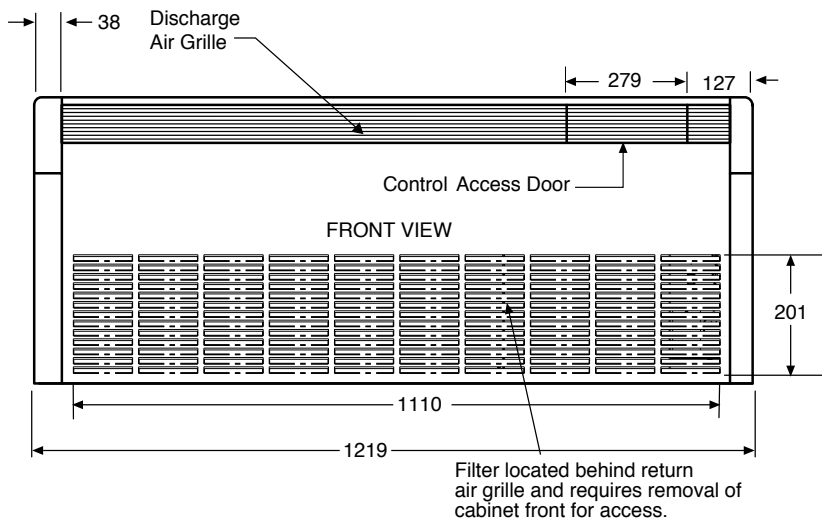

Notes:

1. All dimensions are in mm.
2. Access is reduced if optional disconnect box is selected
3. Optional autoflow regulator, motorized water valve, and disconnect box are not shown.
4. Filter is a cleanable polypropylene mesh.

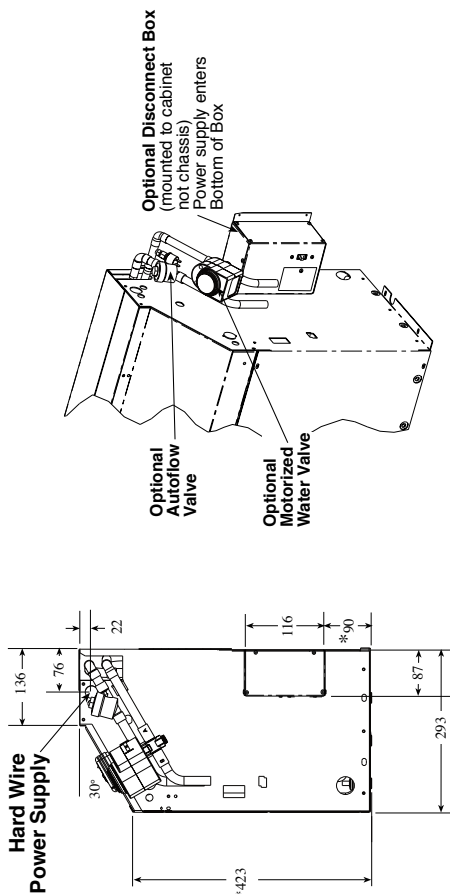

Right Hand Configuration (Bottom Return)

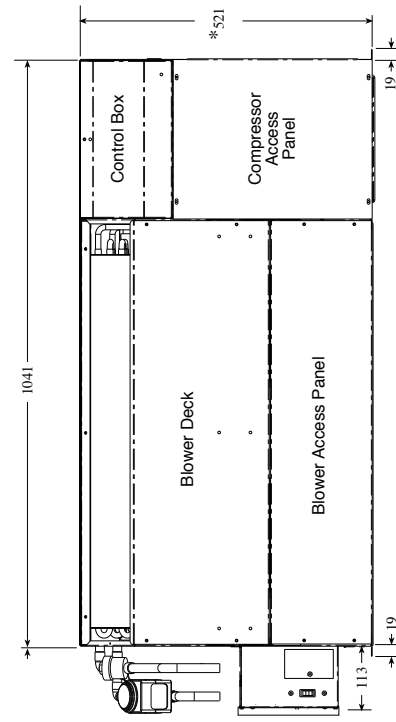

Left Hand Configuration (Bottom Return)

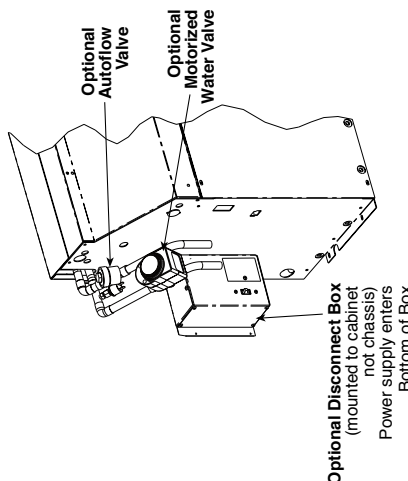
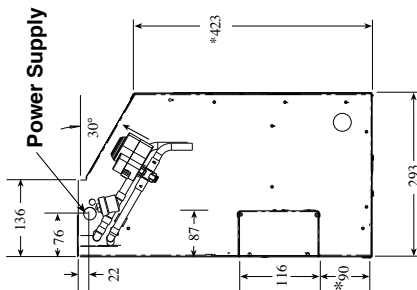

Notes:
 All Dimensions are in millimeters.
 * If subbase option is selected for installed dimension, add to dimension shown 124mm for 5" subbase, or dimension unit is raised above floor (124, minimum)
 Optional autoflow valve, motorized water valve and disconnect box are shown.

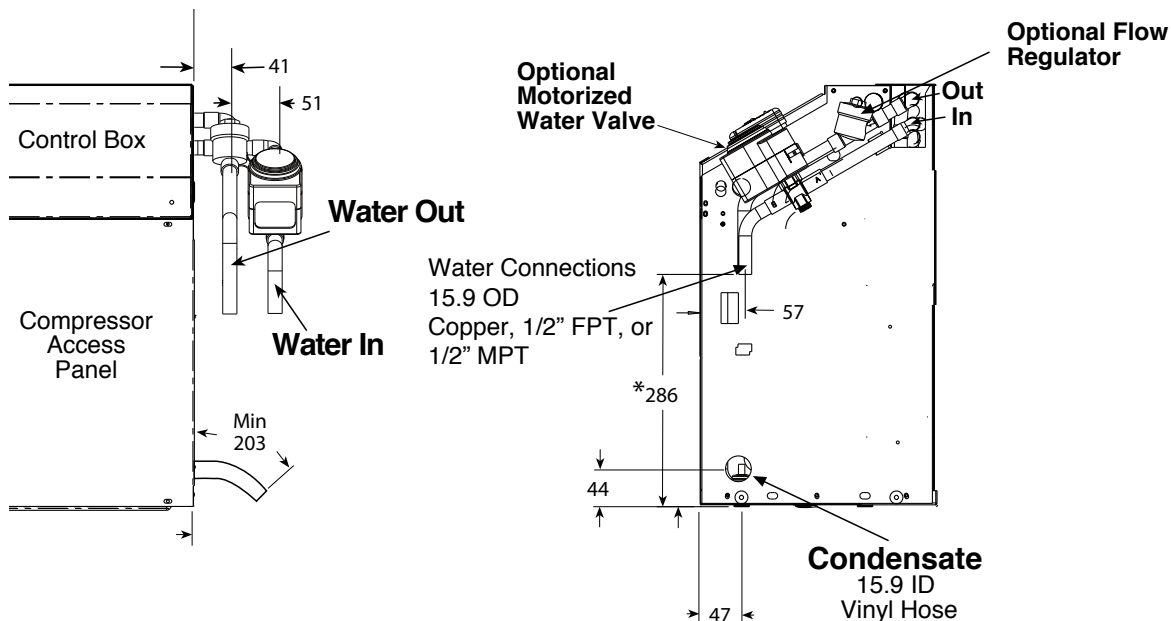

Right Hand Configuration

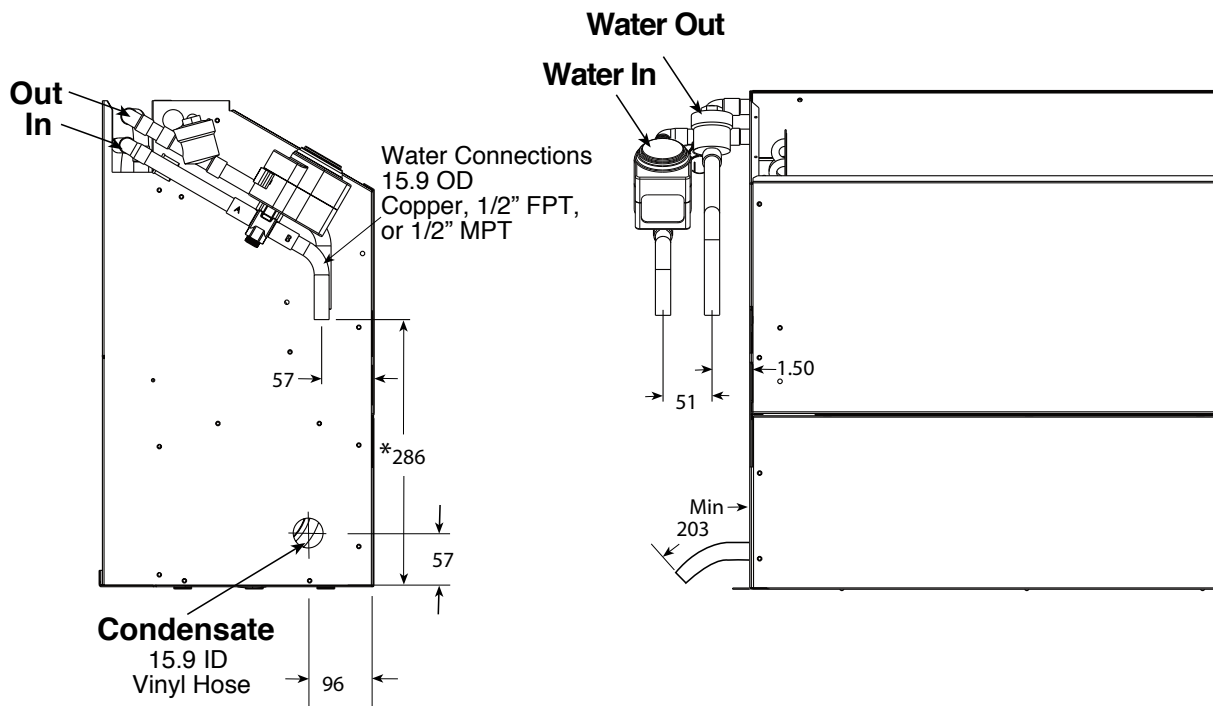

Left Hand Configuration

Notes: * Dimension reduced by fitting if selected.
 Dimensions are in mm.
 Optional autoflow valve and motorized water valve are shown.



Left Hand Bottom Return

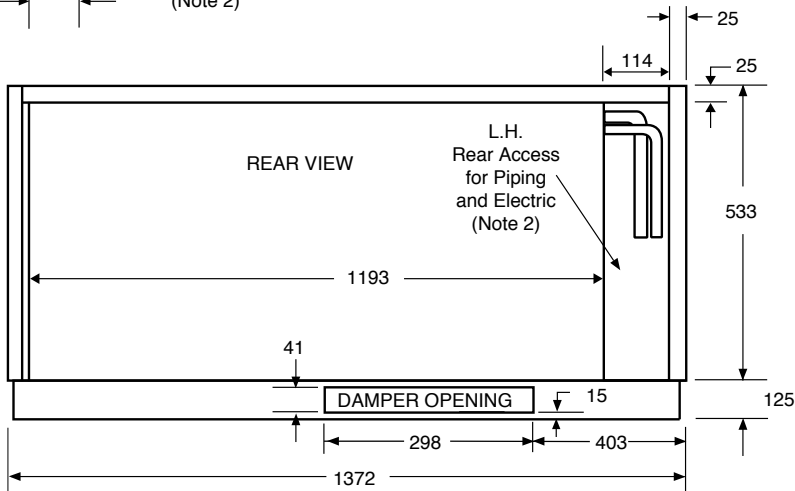
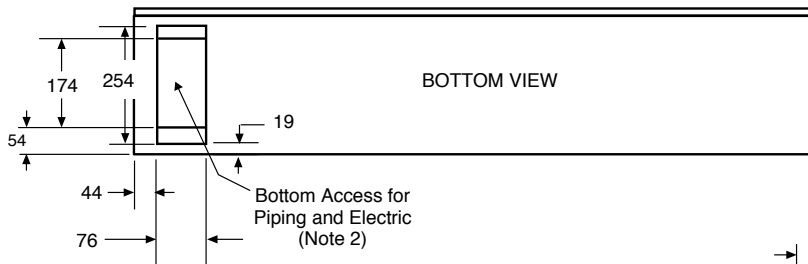
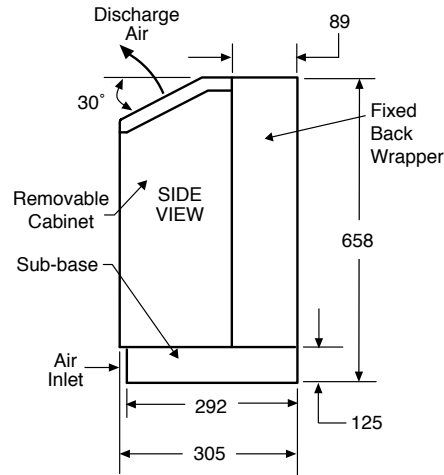
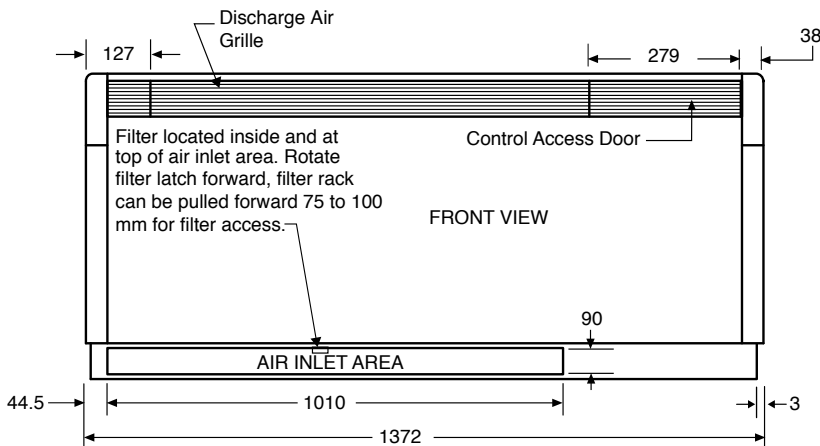

Notes:

1. All Dimensions are in mm.
2. Access is reduced if optional disconnect box is selected.
3. Optional autoflow regulator, motorized water valve, and disconnect box are not shown.
4. Filter is 25 mm thick fiberglass throwaway.



Left Hand Front Return

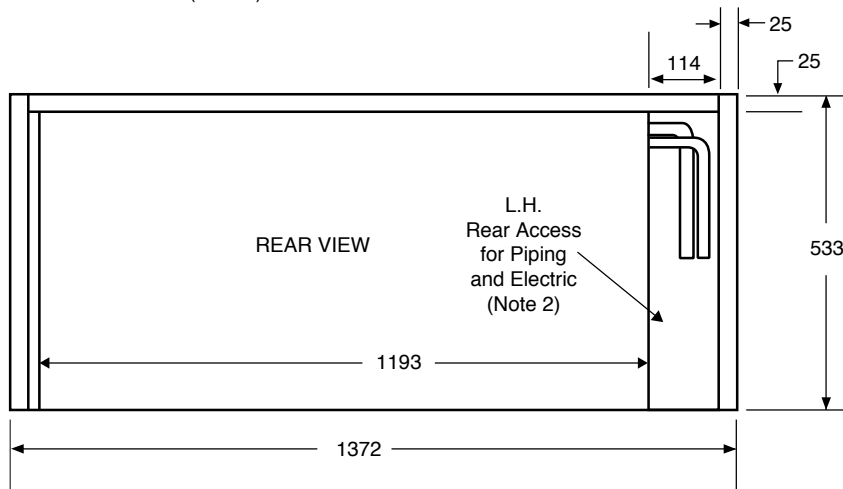
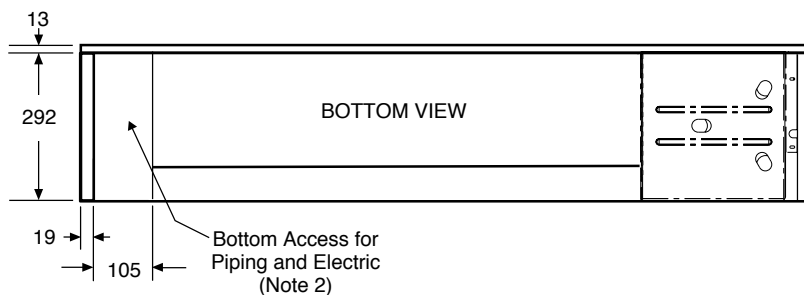
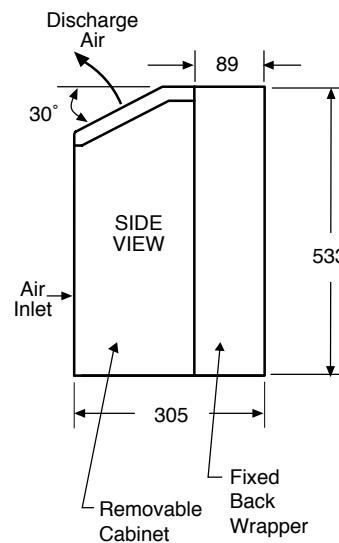
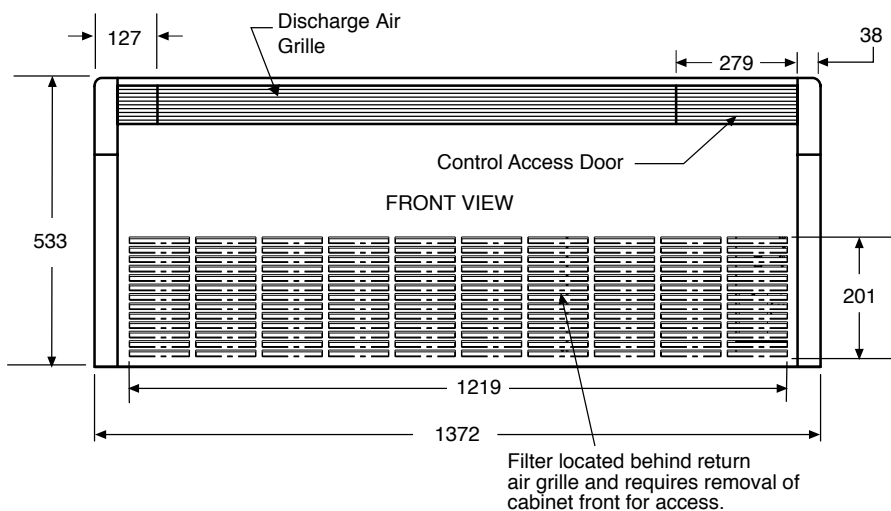

Notes:

1. All Dimensions are in mm.
2. Access is reduced if optional disconnect box is selected.
3. Optional autoflow regulator, motorized water valve, and disconnect box are not shown.
4. Filter is a cleanable polypropylene mesh.



Console Cabinet Dimensions - Size 18
Bottom Return - Right Hand Piping

Right Hand Bottom Return

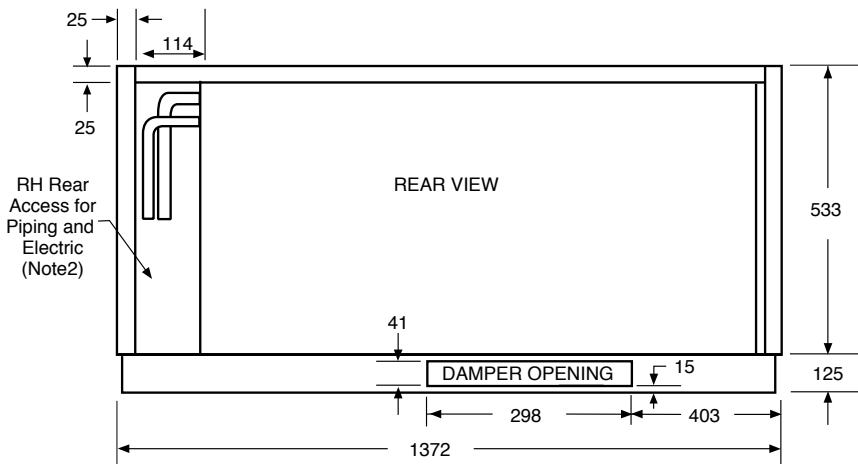
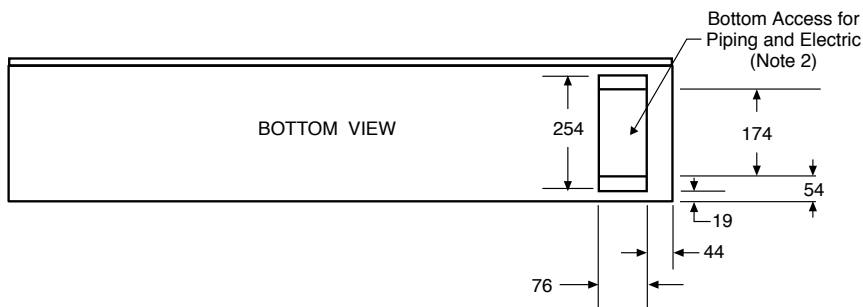
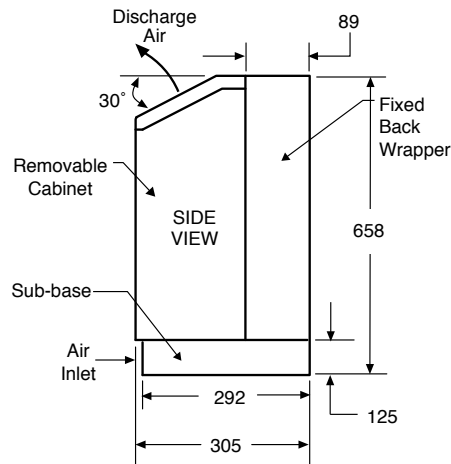
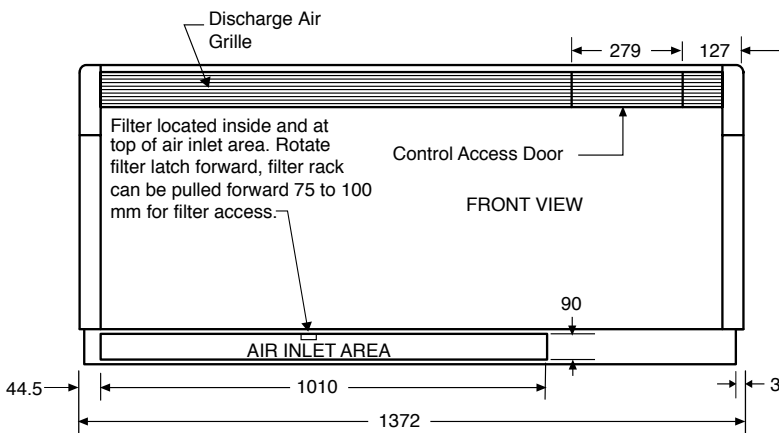

Notes:

1. All Dimensions are in mm.
2. Access is reduced if optional disconnect box is selected.
3. Optional autoflow regulator, motorized water valve, and disconnect box are not shown.
4. Filter is 25 mm thick fiberglass throwaway.



Console Cabinet Dimensions - Size 18
Front Return - Right Hand Piping

Right Hand Front Return

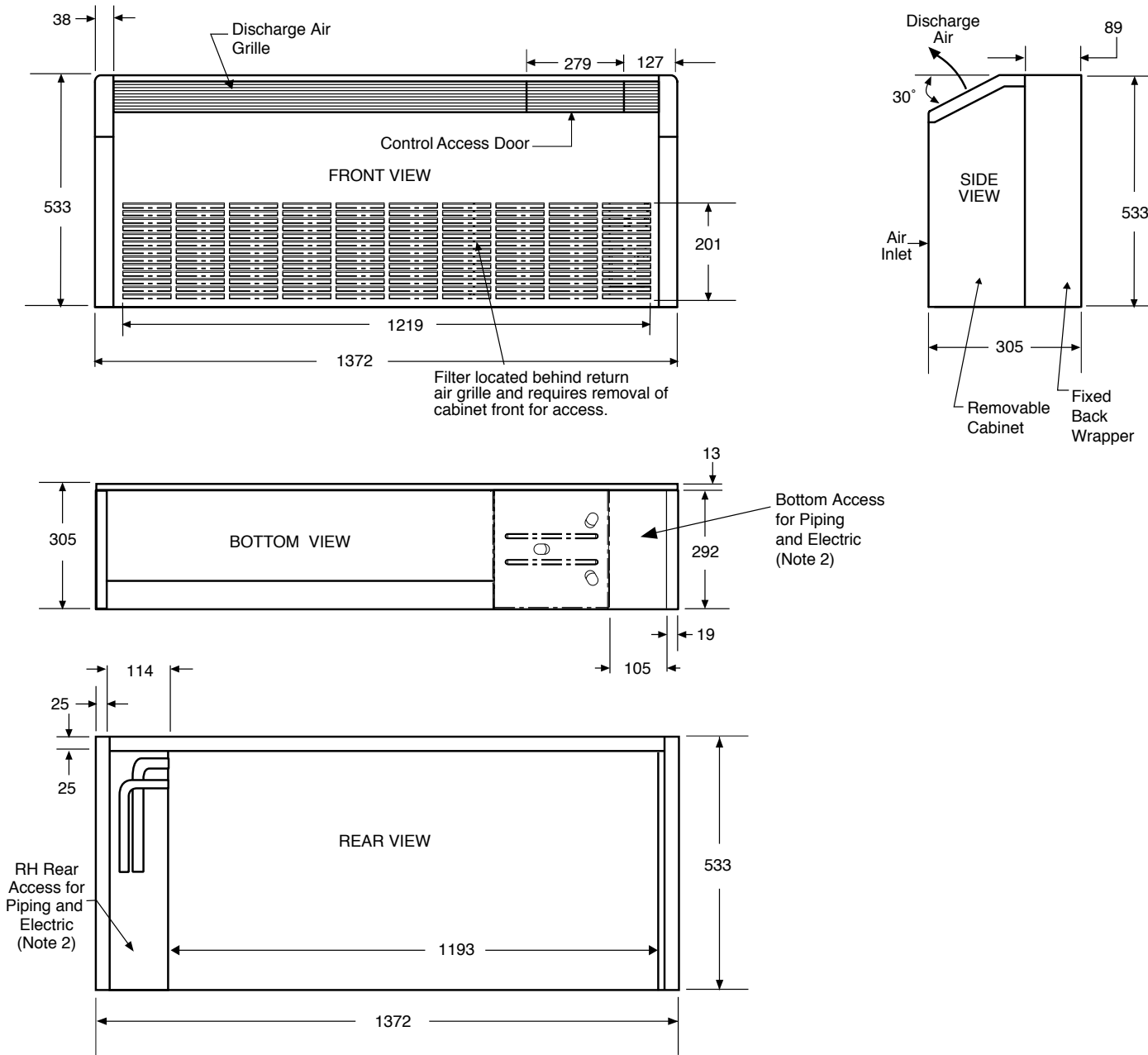

Notes:

1. All Dimensions are in mm.
2. Access is reduced if optional disconnect box is selected.
3. Optional autoflow regulator, motorized water valve, and disconnect box are not shown.
4. Filter is a cleanable polypropylene mesh.

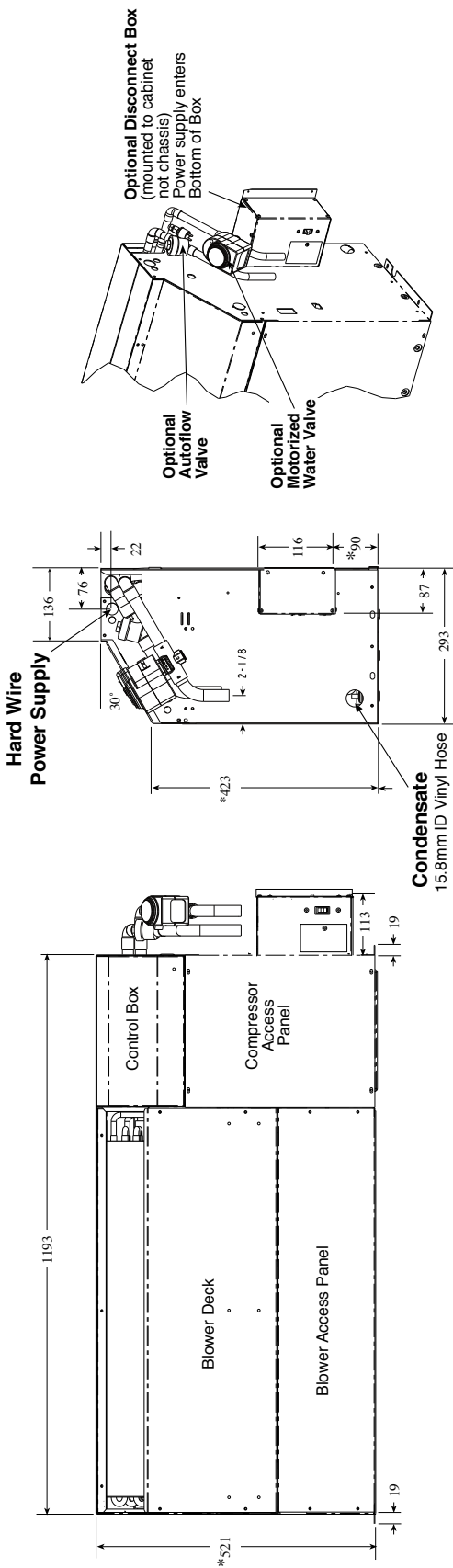

Right Hand Configuration (Bottom Return)

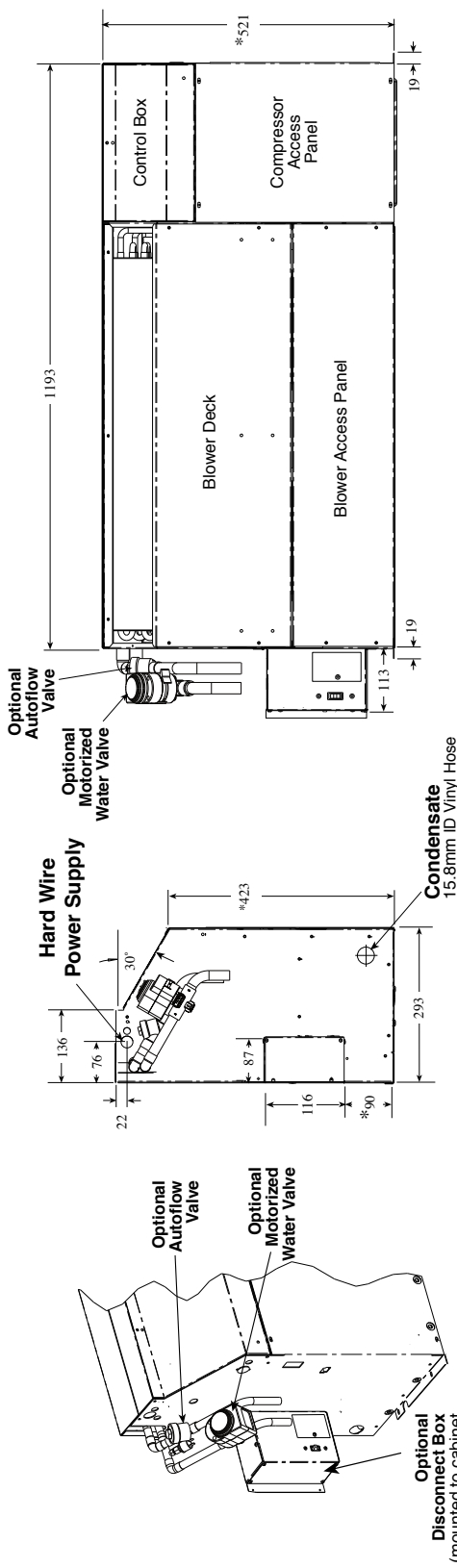

Left Hand Configuration (Bottom Return)

Notes:
 All Dimensions are in millimeters.
 * For installed dimension, add to dimension shown 124mm for 5" subbase.
 Optional autoflow valve, motorized water valve and disconnect box are shown.

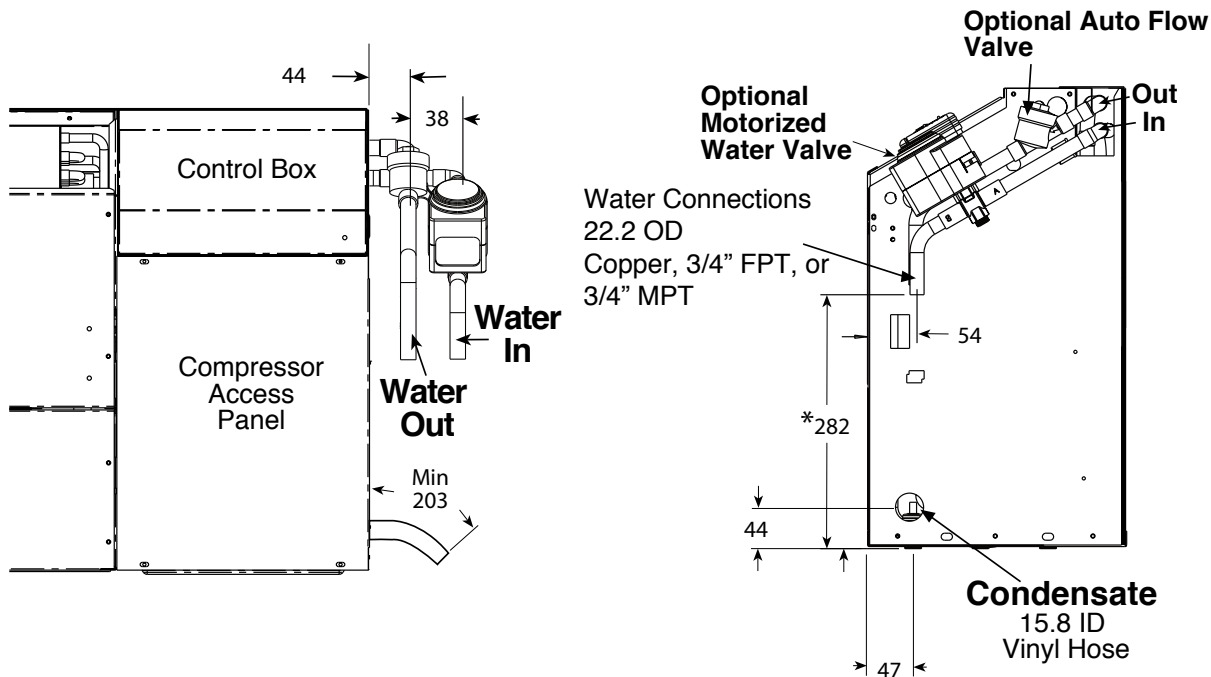

Right Hand Configuration

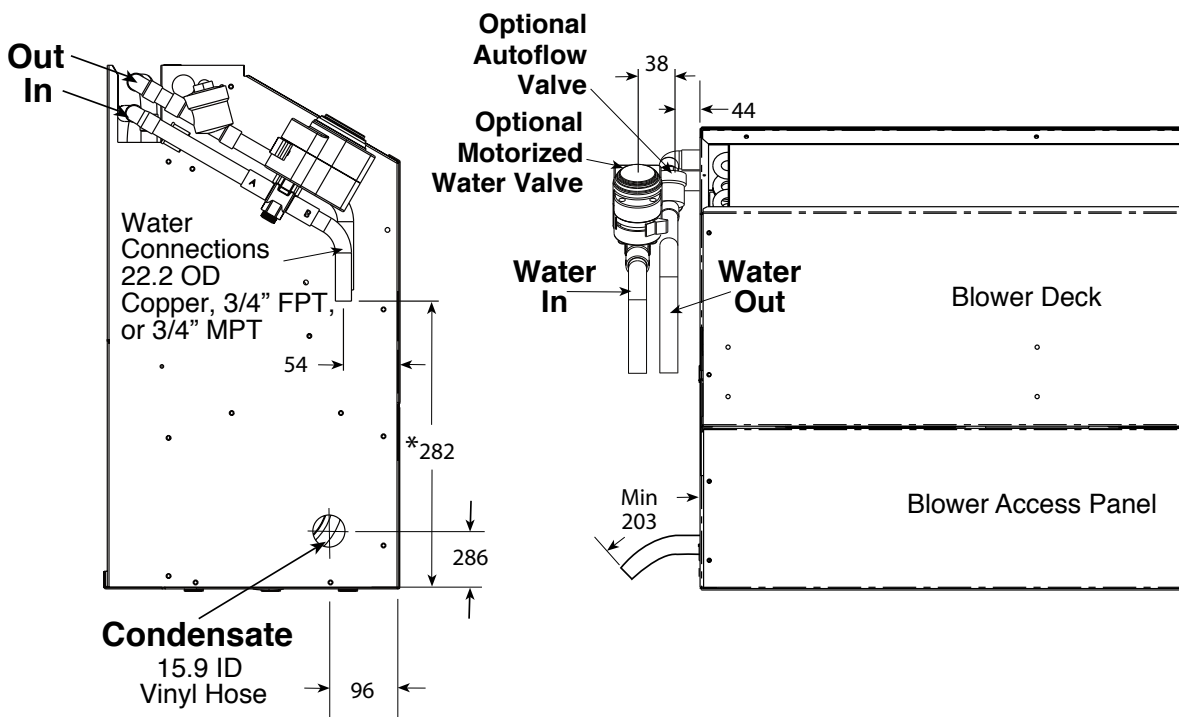

Left Hand Configuration

Notes: * Dimension reduced by fitting if selected
 Dimensions are in mm.
 Optional autoflow valve and motorized water valve are shown.
 Water connection in same location regardless of connection type.



Only CXM and DXM diagrams, with a representative diagram of LON and MPC Options are presented in this submittal. Other diagrams can be located online at climatemaster.com using the part numbers presented below.

Model	Refrigerant	Wiring Diagram Part Number	Electrical	Control	Agency	
TRC09 - TRC18	EarthPure® HFC-410A	96B0099N60	220-240/50/1	CXM	ACO/MCO	CE
		96B0099N61			REM	
		96B0099N62			LON	
		96B0099N63			MPC	
		96B0100N60	220-240/50/1	DXM	ACO/MCO	
		96B0100N61			REM	
		96B0100N62			LON	
		96B0100N63			MPC	

All wiring diagrams available at climatemaster.com.



Typical Wiring Diagram
Manual & Auto Change Over TRC Units - with CXM Controller

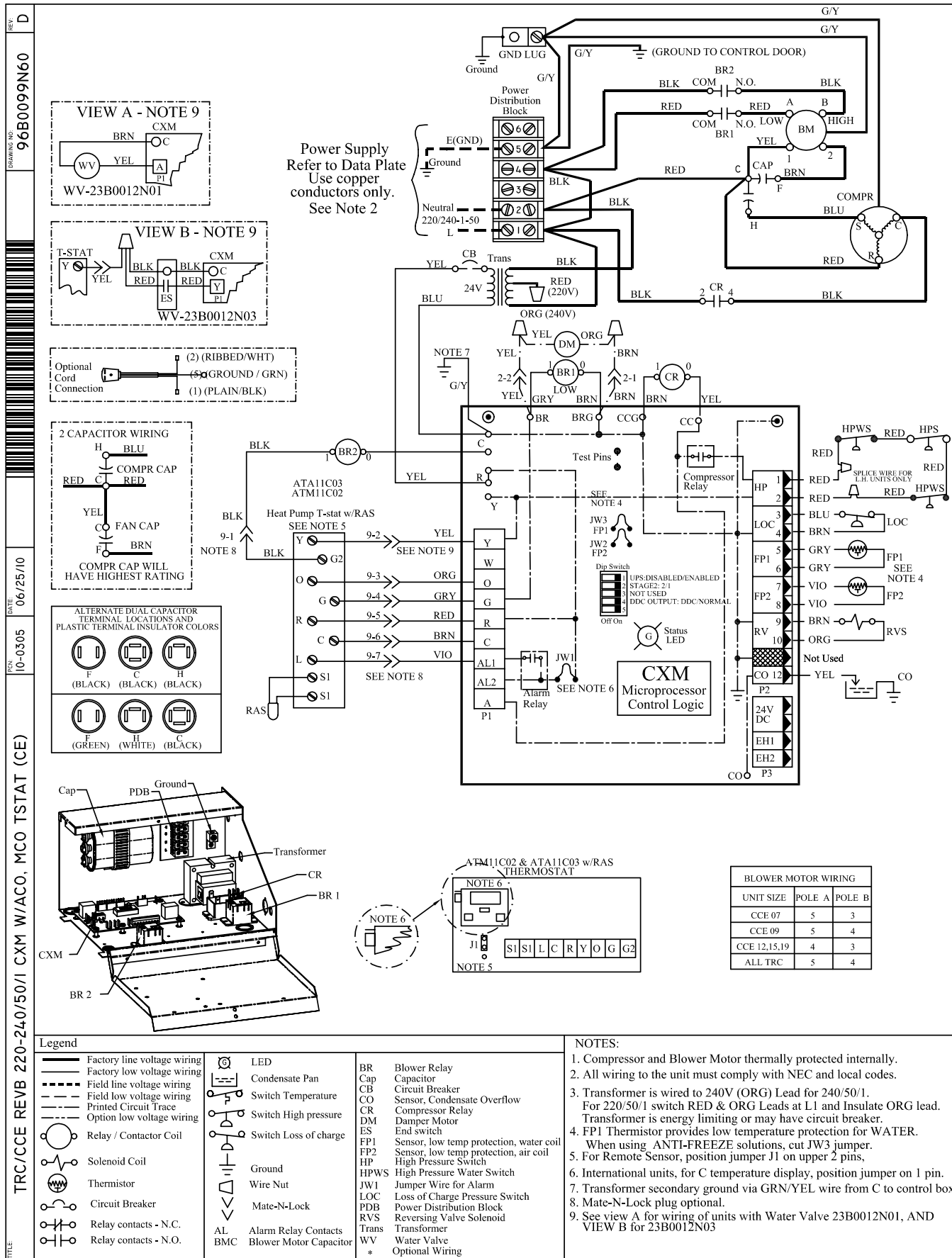



Typical Wiring Diagram
Remote Mounted Thermostat TRC Units - with CXM Controller

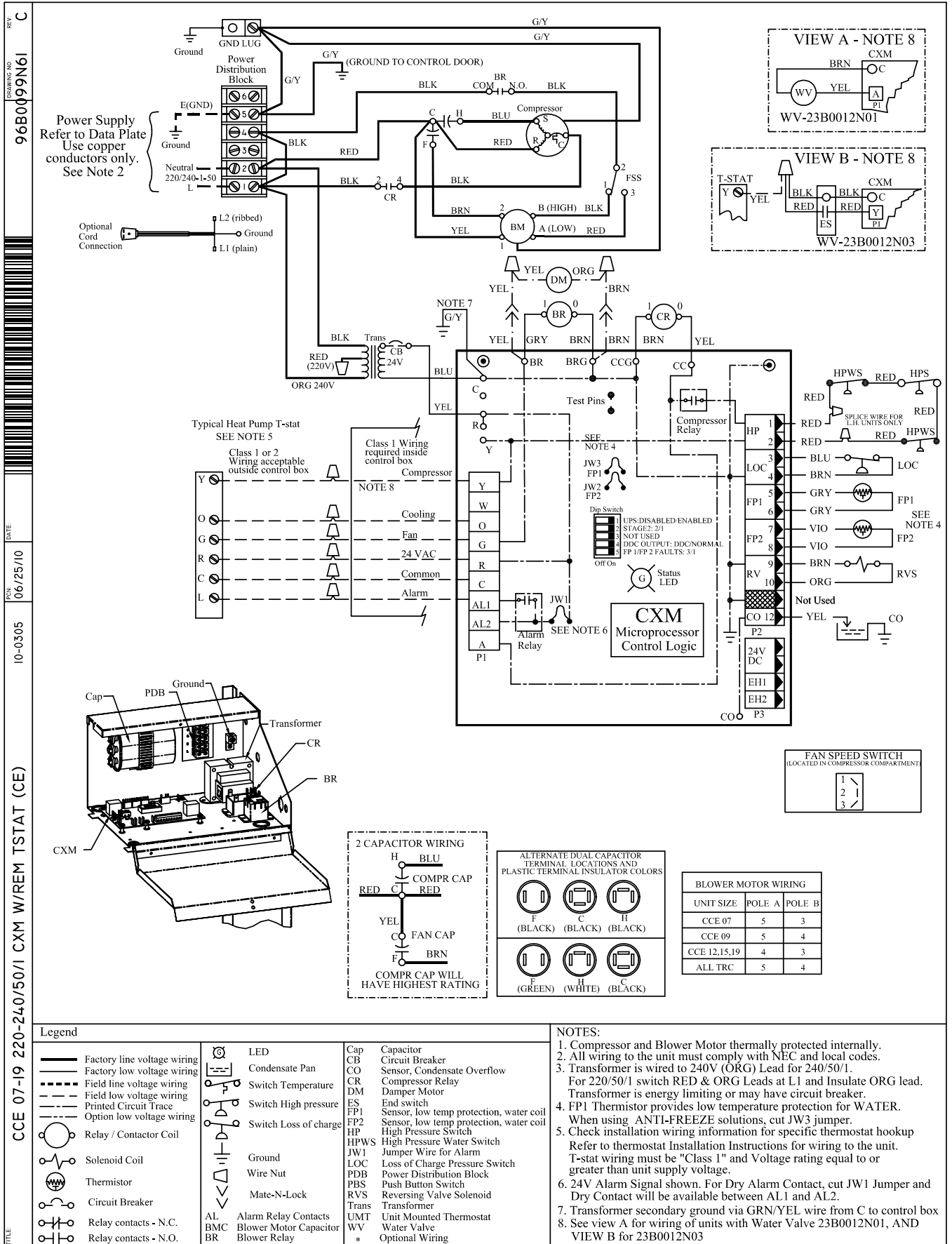



Typical Wiring Diagram
TRC Units with CXM & LON Controller

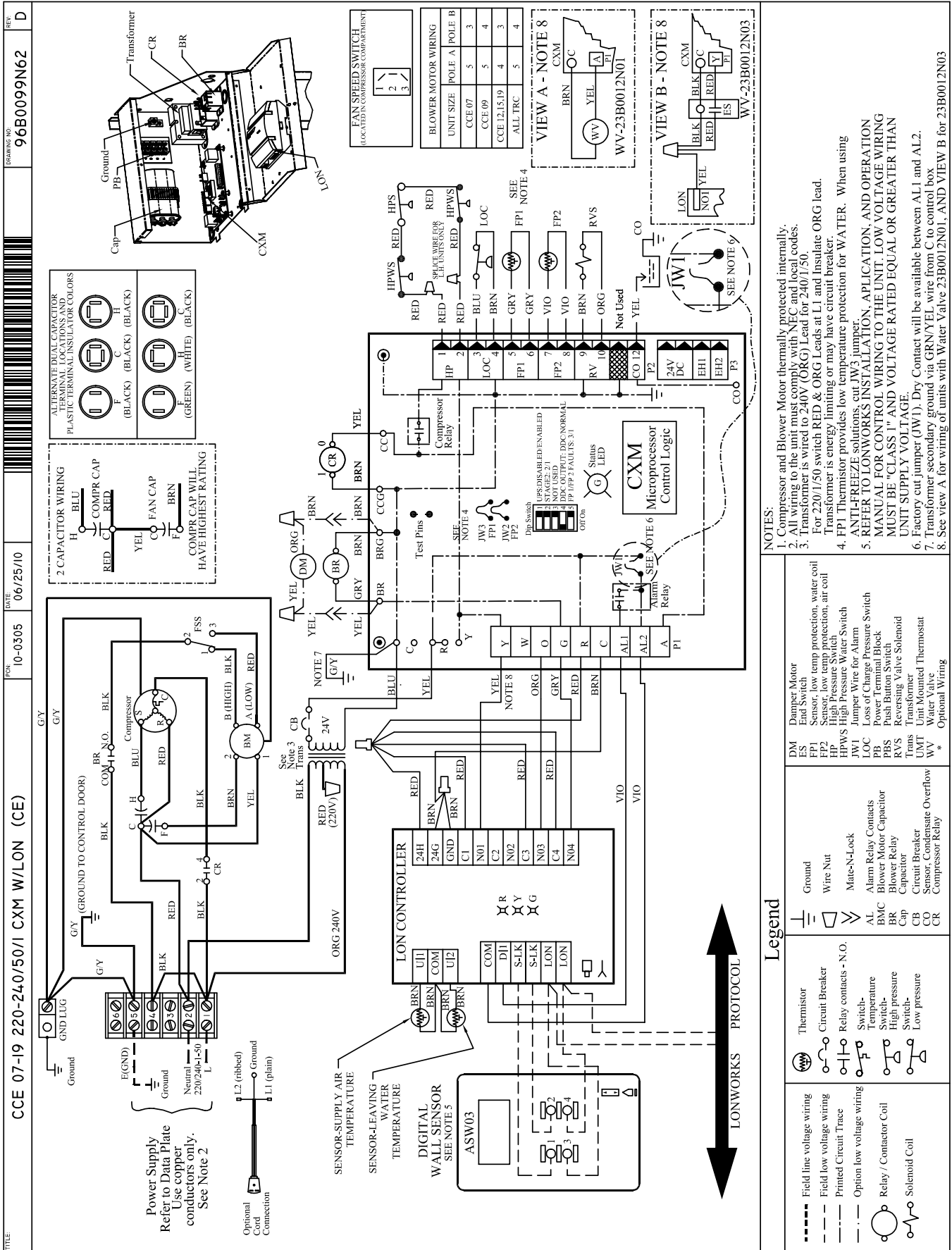



Typical Wiring Diagram
TRC Units with CXM & MPC Controller

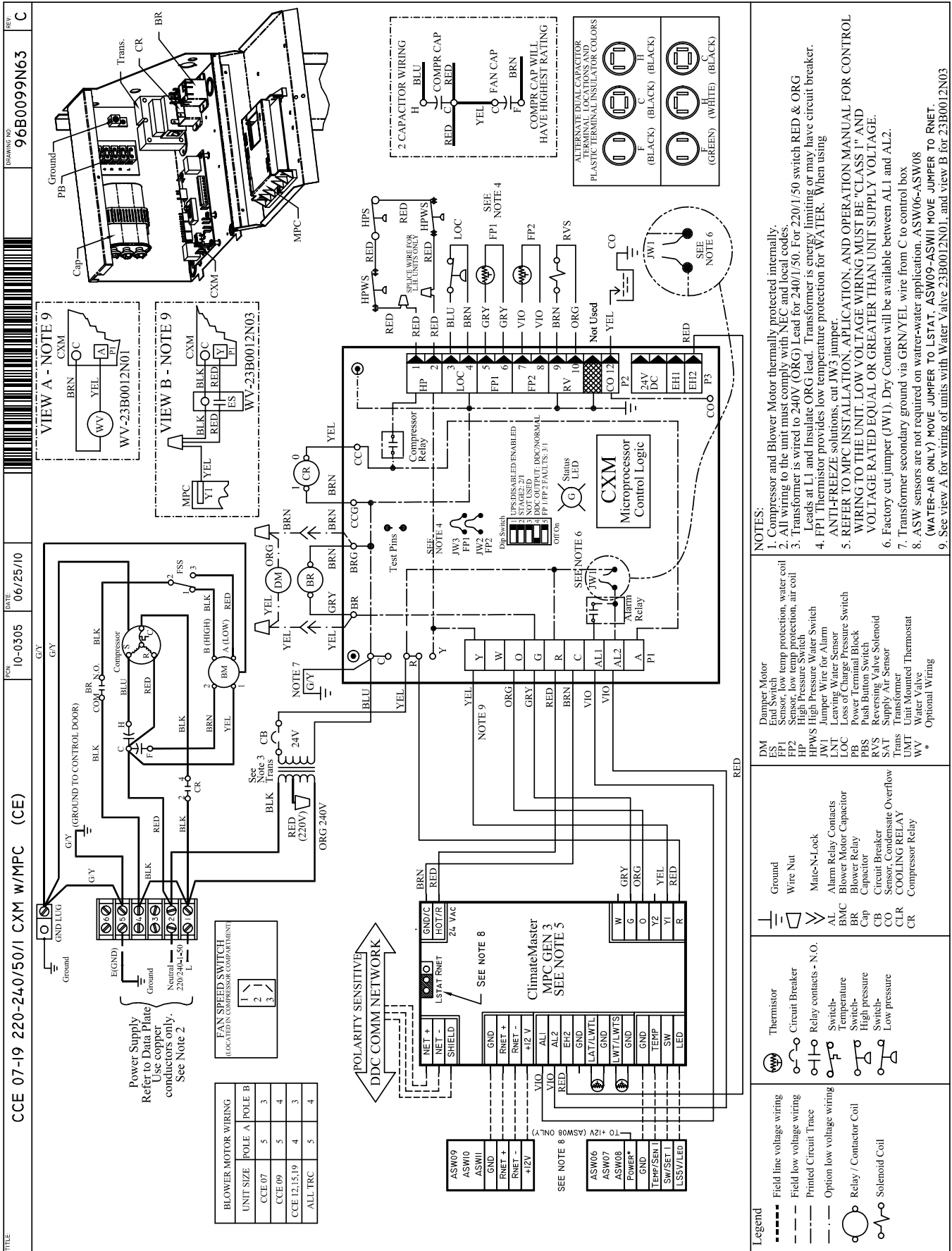

TITLE: CCE 07-19 220-240/50/1 CXM W/MPC (CE) REV: C
 DRAWING NO: 96B0099N63
 DATE: 06/25/10
 P/N: 10-0305

Power Supply Refer to Data Plate Use copper conductors only. See Note 2.

BLOWER MOTOR WIRING

UNIT SIZE	POLE A	POLE B
CCE 07	5	3
CCE 09	5	4
CCE 12,15,19	4	3
ALL TRC	5	4

FAN SPEED SWITCH (LOCATED IN COMPRESSOR COMPARTMENT)

1	2	3
---	---	---

NOTE 1: Compressor and Blower Motor thermally protected internally.
NOTE 2: All wiring to the unit must comply with NEC and local codes.
NOTE 3: Transformer is wired to 240V (ORG) Lead for 240V/50. For 220V/50 switch RED & ORG Leads at L1 and Insulate ORG lead. Transformer is energy limiting or may have circuit breaker.
NOTE 4: FPI Thermistor provides low temperature protection for WATER. When using ANTI-FREEZE solutions, cut JW3 jumper.
NOTE 5: REFER TO MPC INSTALLATION, APPLICATION, AND OPERATION MANUAL FOR CONTROL WIRING TO THE UNIT. LOW VOLTAGE WIRING MUST BE "CLASS 1" AND VOLTAGE RATED EQUAL OR GREATER THAN UNIT SUPPLY VOLTAGE.
NOTE 6: Factory cut jumper (JW1). Dry Contact will be available between AL1 and AL2.
NOTE 7: Transformer secondary ground via GRN/YEL wire from C to control box.
NOTE 8: ASW sensors are not required on water-water application. ASW06-ASW08 (WATER-AIR ONLY) MOVE JUMPER TO LSTAT; ASW09-ASW11 MOVE JUMPER TO RNET.
NOTE 9: See view A for wiring of units with Water Valve 23B0012N01, and view B for 23B0012N03

Legend

- Thermistor
- Circuit Breaker
- Relay contacts - N.O.
- Switch
- Temperature Switch
- High pressure Switch
- Low pressure Switch

Legend

- Ground
- Wire Nut
- Mate-N-Lock
- Alarm Relay Contacts
- Blower Motor Capacitor
- Blower Relay
- Cap
- Circuit Breaker
- Sensor
- CONDENSATE OVERFLOW COOLING RELAY
- Compressor Relay

Legend

- Field line voltage wiring
- Field low voltage wiring
- Printed Circuit Trace
- Option low voltage wiring
- Relay / Contactor Coil
- Solenoid Coil

Legend

- Thermistor
- Circuit Breaker
- Relay contacts - N.O.
- Switch
- Temperature Switch
- High pressure Switch
- Low pressure Switch

Legend

- Ground
- Wire Nut
- Mate-N-Lock
- Alarm Relay Contacts
- Blower Motor Capacitor
- Blower Relay
- Cap
- Circuit Breaker
- Sensor
- CONDENSATE OVERFLOW COOLING RELAY
- Compressor Relay

Legend

- Field line voltage wiring
- Field low voltage wiring
- Printed Circuit Trace
- Option low voltage wiring
- Relay / Contactor Coil
- Solenoid Coil

Legend

- Thermistor
- Circuit Breaker
- Relay contacts - N.O.
- Switch
- Temperature Switch
- High pressure Switch
- Low pressure Switch

Legend

- Ground
- Wire Nut
- Mate-N-Lock
- Alarm Relay Contacts
- Blower Motor Capacitor
- Blower Relay
- Cap
- Circuit Breaker
- Sensor
- CONDENSATE OVERFLOW COOLING RELAY
- Compressor Relay

Legend

- Field line voltage wiring
- Field low voltage wiring
- Printed Circuit Trace
- Option low voltage wiring
- Relay / Contactor Coil
- Solenoid Coil

Legend

- Thermistor
- Circuit Breaker
- Relay contacts - N.O.
- Switch
- Temperature Switch
- High pressure Switch
- Low pressure Switch

Legend

- Ground
- Wire Nut
- Mate-N-Lock
- Alarm Relay Contacts
- Blower Motor Capacitor
- Blower Relay
- Cap
- Circuit Breaker
- Sensor
- CONDENSATE OVERFLOW COOLING RELAY
- Compressor Relay

Legend

- Field line voltage wiring
- Field low voltage wiring
- Printed Circuit Trace
- Option low voltage wiring
- Relay / Contactor Coil
- Solenoid Coil

Legend

- Thermistor
- Circuit Breaker
- Relay contacts - N.O.
- Switch
- Temperature Switch
- High pressure Switch
- Low pressure Switch

Legend

- Ground
- Wire Nut
- Mate-N-Lock
- Alarm Relay Contacts
- Blower Motor Capacitor
- Blower Relay
- Cap
- Circuit Breaker
- Sensor
- CONDENSATE OVERFLOW COOLING RELAY
- Compressor Relay

Legend

- Field line voltage wiring
- Field low voltage wiring
- Printed Circuit Trace
- Option low voltage wiring
- Relay / Contactor Coil
- Solenoid Coil

Legend

- Thermistor
- Circuit Breaker
- Relay contacts - N.O.
- Switch
- Temperature Switch
- High pressure Switch
- Low pressure Switch

Legend

- Ground
- Wire Nut
- Mate-N-Lock
- Alarm Relay Contacts
- Blower Motor Capacitor
- Blower Relay
- Cap
- Circuit Breaker
- Sensor
- CONDENSATE OVERFLOW COOLING RELAY
- Compressor Relay

Legend

- Field line voltage wiring
- Field low voltage wiring
- Printed Circuit Trace
- Option low voltage wiring
- Relay / Contactor Coil
- Solenoid Coil

Legend

- Thermistor
- Circuit Breaker
- Relay contacts - N.O.
- Switch
- Temperature Switch
- High pressure Switch
- Low pressure Switch

Legend

- Ground
- Wire Nut
- Mate-N-Lock
- Alarm Relay Contacts
- Blower Motor Capacitor
- Blower Relay
- Cap
- Circuit Breaker
- Sensor
- CONDENSATE OVERFLOW COOLING RELAY
- Compressor Relay

Legend

- Field line voltage wiring
- Field low voltage wiring
- Printed Circuit Trace
- Option low voltage wiring
- Relay / Contactor Coil
- Solenoid Coil

Legend

- Thermistor
- Circuit Breaker
- Relay contacts - N.O.
- Switch
- Temperature Switch
- High pressure Switch
- Low pressure Switch

Legend

- Ground
- Wire Nut
- Mate-N-Lock
- Alarm Relay Contacts
- Blower Motor Capacitor
- Blower Relay
- Cap
- Circuit Breaker
- Sensor
- CONDENSATE OVERFLOW COOLING RELAY
- Compressor Relay

Legend

- Field line voltage wiring
- Field low voltage wiring
- Printed Circuit Trace
- Option low voltage wiring
- Relay / Contactor Coil
- Solenoid Coil

Legend

- Thermistor
- Circuit Breaker
- Relay contacts - N.O.
- Switch
- Temperature Switch
- High pressure Switch
- Low pressure Switch

Legend

- Ground
- Wire Nut
- Mate-N-Lock
- Alarm Relay Contacts
- Blower Motor Capacitor
- Blower Relay
- Cap
- Circuit Breaker
- Sensor
- CONDENSATE OVERFLOW COOLING RELAY
- Compressor Relay

Legend

- Field line voltage wiring
- Field low voltage wiring
- Printed Circuit Trace
- Option low voltage wiring
- Relay / Contactor Coil
- Solenoid Coil

Legend

- Thermistor
- Circuit Breaker
- Relay contacts - N.O.
- Switch
- Temperature Switch
- High pressure Switch
- Low pressure Switch

Legend

- Ground
- Wire Nut
- Mate-N-Lock
- Alarm Relay Contacts
- Blower Motor Capacitor
- Blower Relay
- Cap
- Circuit Breaker
- Sensor
- CONDENSATE OVERFLOW COOLING RELAY
- Compressor Relay

Legend

- Field line voltage wiring
- Field low voltage wiring
- Printed Circuit Trace
- Option low voltage wiring
- Relay / Contactor Coil
- Solenoid Coil

Legend

- Thermistor
- Circuit Breaker
- Relay contacts - N.O.
- Switch
- Temperature Switch
- High pressure Switch
- Low pressure Switch

Legend

- Ground
- Wire Nut
- Mate-N-Lock
- Alarm Relay Contacts
- Blower Motor Capacitor
- Blower Relay
- Cap
- Circuit Breaker
- Sensor
- CONDENSATE OVERFLOW COOLING RELAY
- Compressor Relay

Legend

- Field line voltage wiring
- Field low voltage wiring
- Printed Circuit Trace
- Option low voltage wiring
- Relay / Contactor Coil
- Solenoid Coil

Legend

- Thermistor
- Circuit Breaker
- Relay contacts - N.O.
- Switch
- Temperature Switch
- High pressure Switch
- Low pressure Switch

Legend

- Ground
- Wire Nut
- Mate-N-Lock
- Alarm Relay Contacts
- Blower Motor Capacitor
- Blower Relay
- Cap
- Circuit Breaker
- Sensor
- CONDENSATE OVERFLOW COOLING RELAY
- Compressor Relay

Legend

- Field line voltage wiring
- Field low voltage wiring
- Printed Circuit Trace
- Option low voltage wiring
- Relay / Contactor Coil
- Solenoid Coil

Legend

- Thermistor
- Circuit Breaker
- Relay contacts - N.O.
- Switch
- Temperature Switch
- High pressure Switch
- Low pressure Switch

Legend

- Ground
- Wire Nut
- Mate-N-Lock
- Alarm Relay Contacts
- Blower Motor Capacitor
- Blower Relay
- Cap
- Circuit Breaker
- Sensor
- CONDENSATE OVERFLOW COOLING RELAY
- Compressor Relay



Typical Wiring Diagram
Manual & AutoChange Over TRC Unitsm - with DXM Controller

BLOWER MOTOR WIRING		
UNIT SIZE	POLE A	POLE B
CCE 07	5	3
CCE 09	5	4
CCE 12,15,19	4	3
ALL TRC	5	4

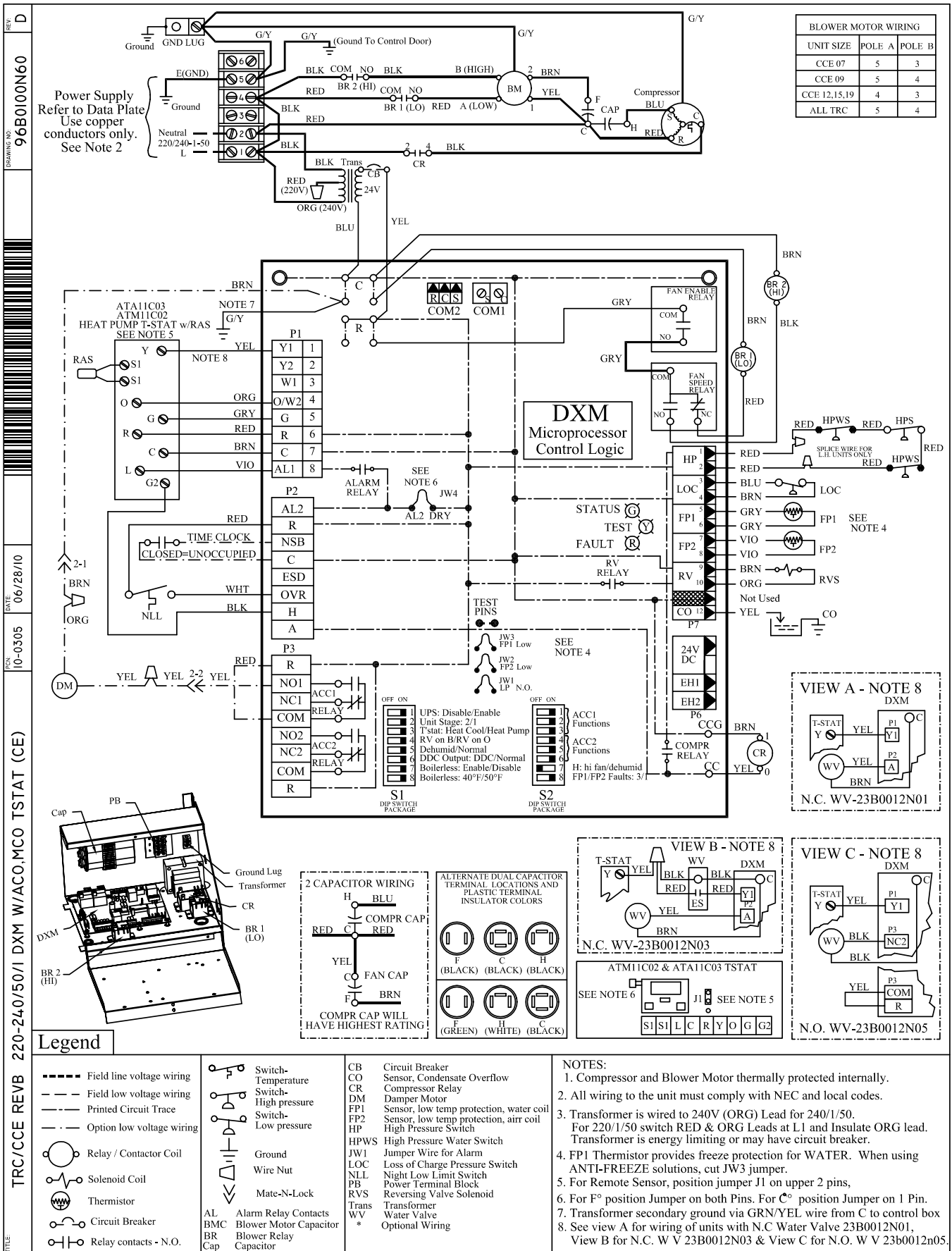

REV. D
DRAWING NO. 96B0100N60
DATE 06/28/10
PCN 10-0305
TITLE TRC/CCE REV B 220-240/50/1 DXM W/ACO,MCO TSTAT (CE)

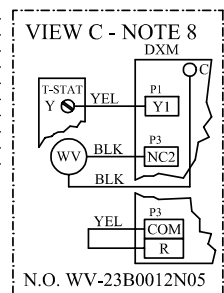
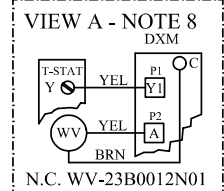
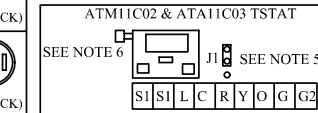
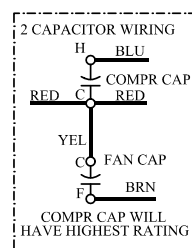
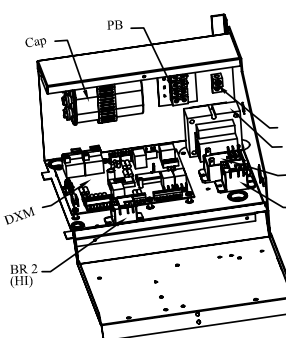



Typical Wiring Diagram
Remote Mounted Thermostat TRC Units - with DXM Controller

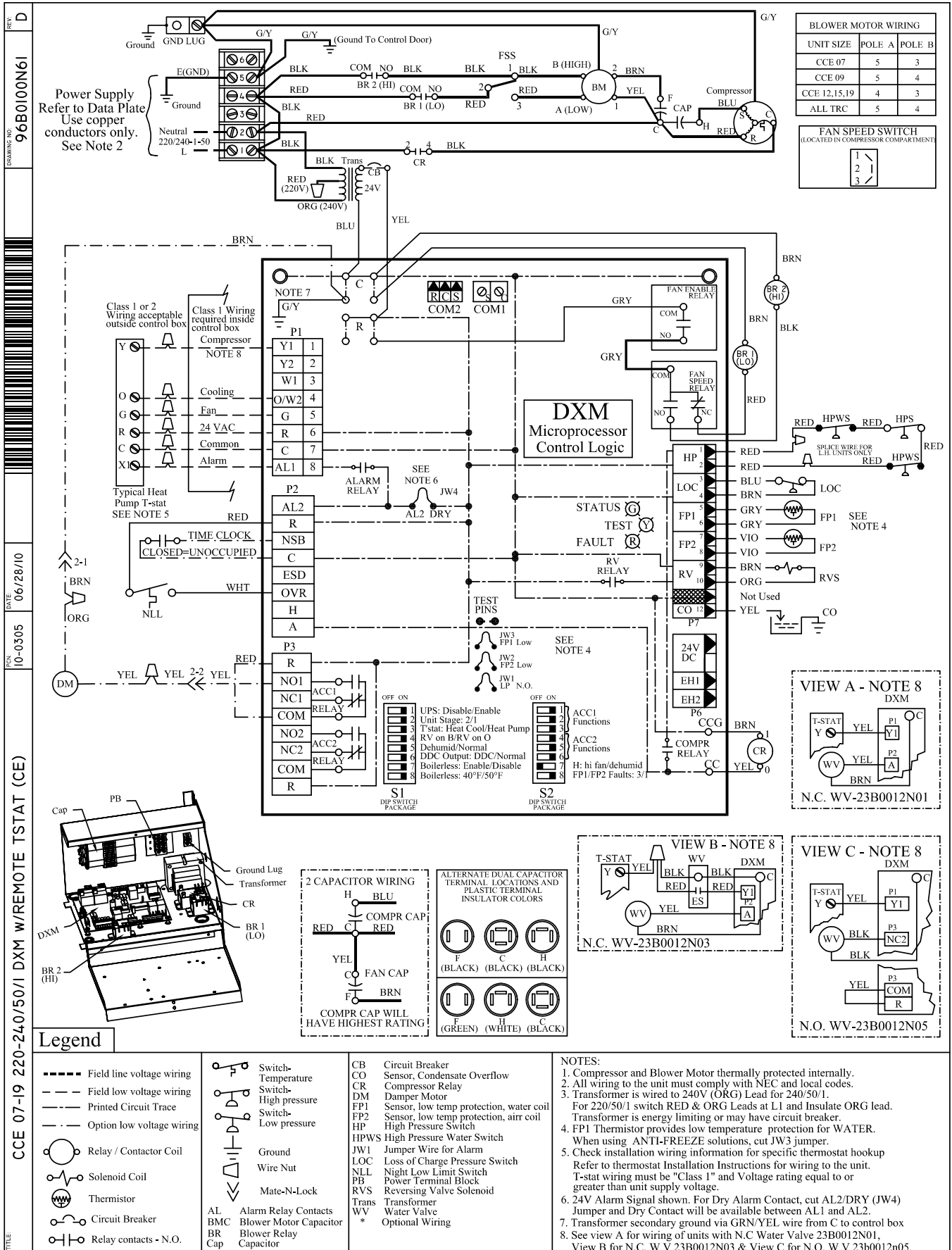



Typical Wiring Diagram
TRC Units with DXM & LON Controller

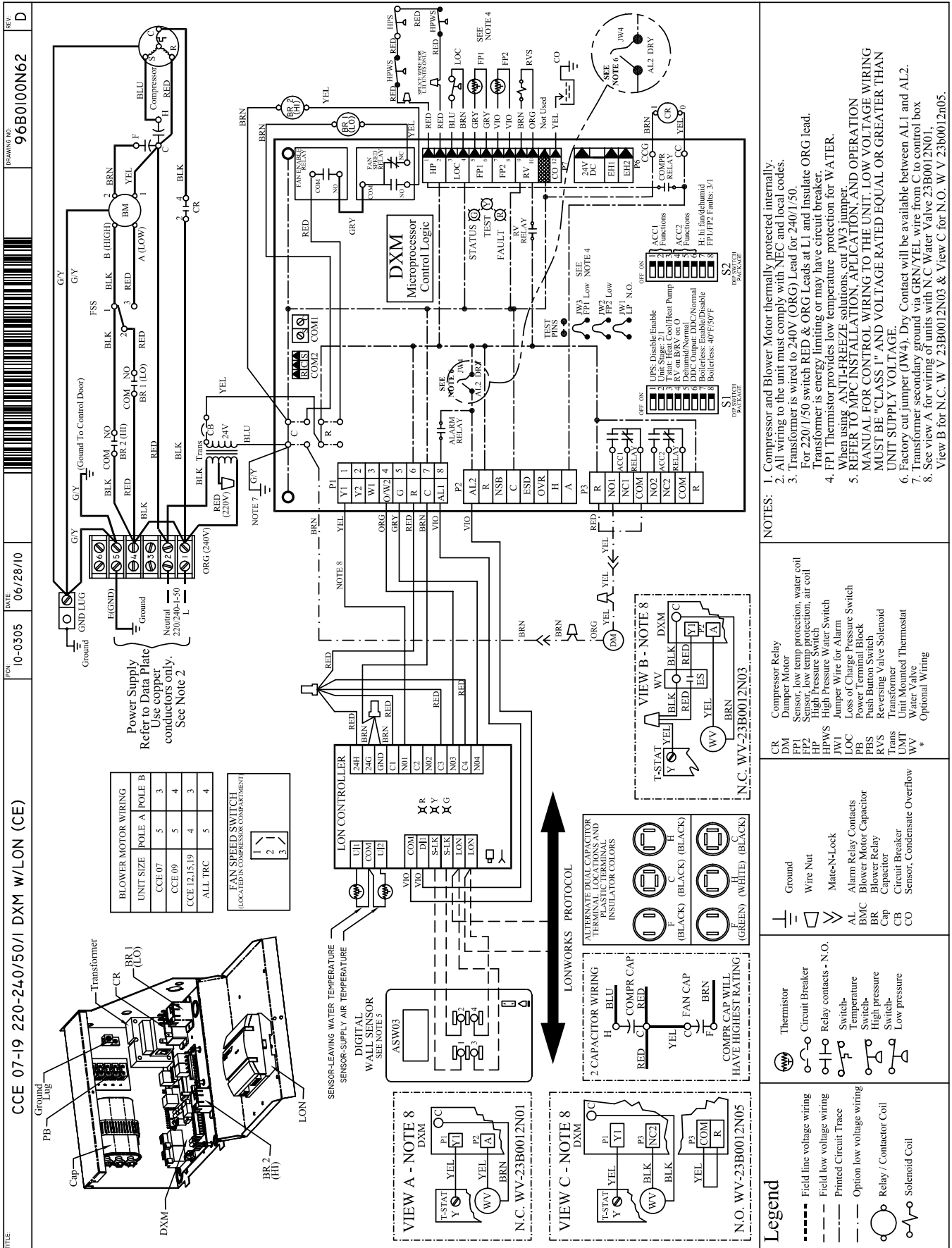



Typical Wiring Diagram
TRC Units with DXM & MPC Controller

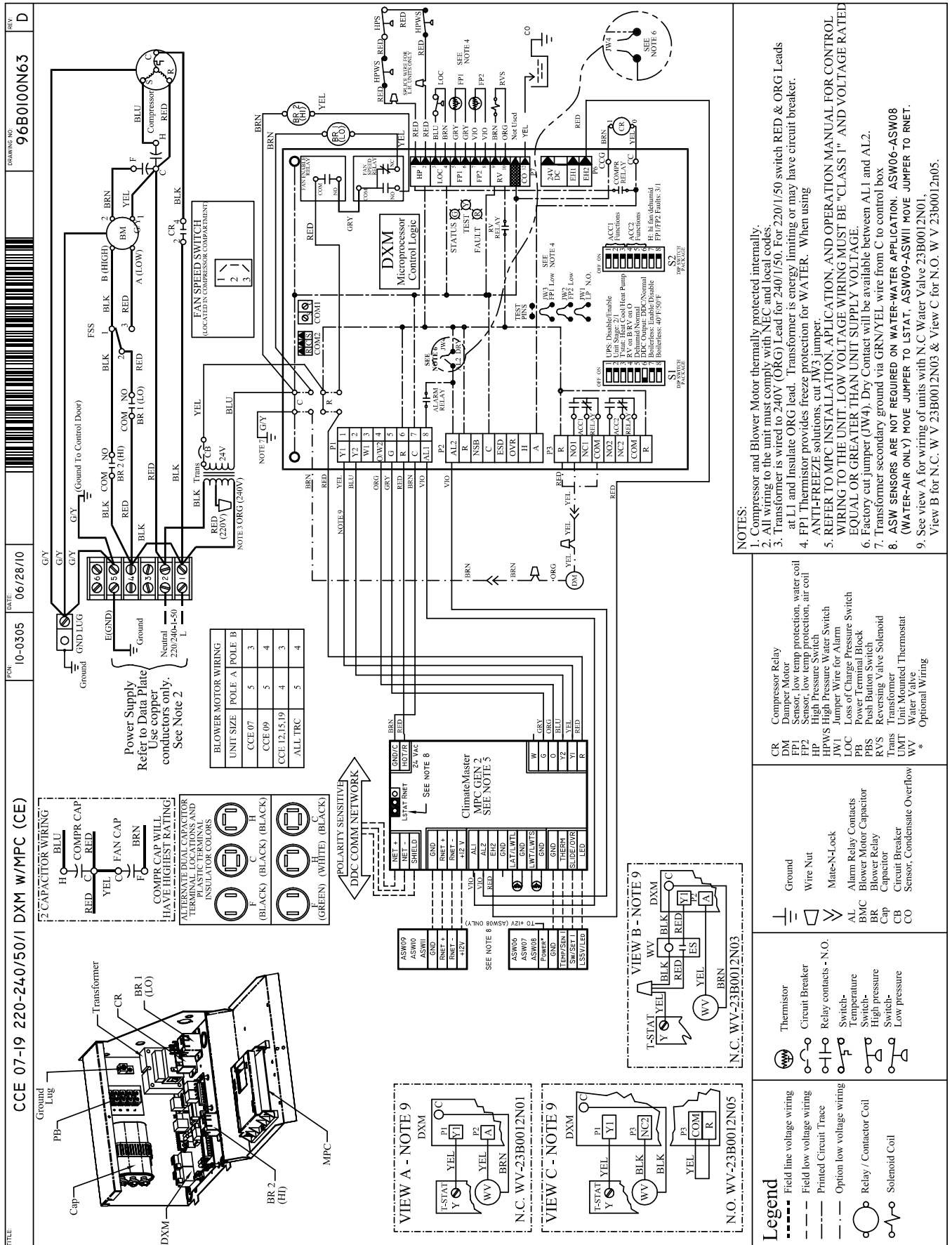

ClimateMaster works continually to improve its products. As a result, the design and specifications of each product at the time of order may be changed without notice and may not be as described herein. Please contact ClimateMaster's Customer Service Department at +1-405-745-6000 for specific information on the current design and specifications. Statements and other information contained herein are not express warranties and do not form the basis of any bargain between the parties, but are merely ClimateMaster's opinion or commendation of its products. The latest version of this document is available at climatemaster.com.

**General:**

Furnish and install ClimateMaster Tranquility® "Console" Water Source Heat Pumps, as indicated on the plans. Equipment shall be completely assembled, piped and internally wired. Capacities and characteristics as listed in the schedule and the specifications that follow.

Units shall be supplied completely factory built capable of operating over an entering water temperature range from -6.7° to 48.9°C as standard. Equivalent units from other manufacturers may be proposed provided approval to bid is given 10 days prior to bid closing. All equipment listed in this section must be rated in accordance with Air-Conditioning, Heating and Refrigeration Institute/International Standards Organization (AHRI/ISO 13256-1). The units shall have CE label.

All units shall be fully quality tested by factory run testing under normal operating conditions as described herein. Quality control system shall automatically perform via computer: triple leak check, pressure tests, evacuation and accurately charge system, perform detailed heating and cooling mode tests, and quality cross check all operational and test conditions to pass/fail criteria. Detailed report card will ship with each unit displaying status for critical tests and components. **Note: If unit fails on any cross check, it shall not be allowed to ship. Serial numbers will be recorded by factory and furnished to contractor on report card for ease of unit warranty status. Units tested without water flow are not acceptable.**

Basic Construction:

Console units shall have one of the following air flow and piping arrangements: Front Inlet/Right-hand Piping; Front Inlet/Left-hand piping; Bottom Inlet/Right-hand piping; or Bottom Inlet/Left-hand piping as shown on the plans. If units with these arrangements are NOT used, the contractor is responsible for any extra costs incurred by other trades. If other arrangements make servicing difficult, the contractor must provide access panels and clear routes to ease service. Architect/Engineer must approve any changes in layout.

The cabinet, wall mounted back wrapper and subbase shall be constructed of heavy gauge galvanized steel with a baked polyester powder coat paint finish. Corrosion protection system shall meet the stringent 1000 hour salt spray test per ASTM B117. **Unit corrosion protection must meet these stringent requirements or unit(s) will not be accepted.** Color will be Polar Ice. Both sides of the steel shall be painted for added protection. Additionally, the wall mounted back wrapper shall have welded corner bracing. The easily removable cabinet enclosure allows for easy service to the chassis, piping compartment and control compartment.

All interior surfaces shall be lined with 6.4mm thick, 32 kg/m³ acoustic flexible blanket type glass fiber insulation with a non-woven, anti-microbial treated mat face. Insulation placement shall be designed in a manner that will eliminate any exposed edges to prevent the introduction of glass fibers into the air stream. Standard insulation must meet NFPA Fire Hazard Classification requirements 25/50 per ASTM E84, UL 723, CAN/ULC S102-M88 and NFPA 90A requirements; air erosion and mold growth limits of UL-181; stringent fungal resistance test per ASTM-C1071 and ASTM G21; and shall meet zero level bacteria growth per ASTM G22. **Unit insulation must meet these stringent requirements or unit(s) will not be accepted.**

The cabinet shall have a 30° sloped top with aluminum rigid bar type discharge grille. Aluminum discharge grille shall be anodized charcoal grey in color including hinged control door. Cabinet shall have rounded edges (8.255 mm) minimum radius on all exposed corners for safety and esthetic purposes. **Units not having sloped top and rounded corners (8.255 mm minimum) on front, side, top slope, and top corners shall not be accepted.**

Return Air Filter shall be 25.4mm fiberglass disposable type media for bottom return units (units with subbase) or 3.2mm permanent cleanable type media for front return type units.

Option: The unit shall be provided with a keyed lock on the control access door.

Option: The unit shall be provided with a motorized outside air damper and damper assembly, factory mounted and wired.

Option: The unit shall be provided without a subbase (127mm high subbase is standard).

Option: The unit shall include a front return air grille integrally stamped into Cabinet (subbase not required).

Option: The unit shall include an optional architectural-style field installed return air grille to help conceal the subbase return air opening (units with bottom return only).

Option: UltraQuiet package shall consist of high technology sound attenuating material that is strategically applied to the compressor and compressor compartment in addition to the standard ClimaQuiet system design, to further dampen and attenuate sound transmissions. Compressor is mounted on specially engineered sound-tested EPDM isolators.

Fan and Motor Assembly:

Fan and motor assembly shall be assembled on a slide out fan deck with quick electrical disconnecting means to provide and facilitate easy field servicing. The fan motor shall be multi-speed, permanently lubricated, PSC type, with internal thermal overload protection. Units supplied without permanently lubricated motors must provide external oilers for easy service. The fan motor shall include a torsionally flexible motor mounting system or saddle mount system with resilient rings to inhibit vibration induced high noise levels associated with "hard wire belly band" motor mounting. The airflow rating of the unit shall be based on a wet coil and a clean filter in place. **Ratings based on a dry coil and/or no filter shall NOT be acceptable.**

ClimateMaster works continually to improve its products. As a result, the design and specifications of each product at the time of order may be changed without notice and may not be as described herein. Please contact ClimateMaster's Customer Service Department at +1-405-745-6000 for specific information on the current design and specifications. Statements and other information contained herein are not express warranties and do not form the basis of any bargain between the parties, but are merely ClimateMaster's opinion or commendation of its products. The latest version of this document is available at climatemaster.com.



Refrigerant Circuit:

All units shall contain an EarthPure® (HFC-410A) sealed refrigerant circuit including a high efficiency rotary compressor designed for heat pump operation, a thermostatic expansion valve for refrigerant metering, an enhanced corrugated aluminum lanced fin and rifled copper tube refrigerant to air heat exchanger, reversing valve, coaxial (tube in tube) refrigerant to water heat exchanger, and safety controls including a high pressure switch, low pressure switch (loss of charge), water coil low temperature sensor, and air coil low temperature sensor. Access fittings shall be factory installed on high and low pressure refrigerant lines to facilitate field service. Activation of any safety device shall prevent compressor operation via a microprocessor lockout circuit. The lockout circuit shall be reset at the thermostat or at the optional disconnect switch. **Units that cannot be reset at the thermostat shall not be acceptable.**

Hermetic compressors shall be internally sprung. The compressor will be mounted on specially engineered sound-tested EPDM vibration isolation grommets for maximized vibration attenuation. Compressor shall have thermal overload protection. Compressor shall be located in an insulated compartment away from air stream to minimize sound transmission.

Refrigerant to air heat exchangers shall utilize enhanced corrugated lanced aluminum fins and rifled copper tube construction rated to withstand 4309 kPa refrigerant working pressure. Refrigerant to water heat exchangers shall be of copper inner water tube and steel refrigerant outer tube design, rated to withstand 4309 kPa working refrigerant pressure and 3445 kPa working water pressure. The refrigerant to water heat exchanger shall be coated with a low cure cathodic epoxy material a minimum of 0.4 mils thick (0.4 – 1.5 mils range) on all surfaces. The black colored coating shall provide a minimum of 1000 hours salt spray protection per ASTM B117-97 on all external steel and copper tubing. The material shall be formulated without the inclusion of any heavy metals and shall exhibit a pencil hardness of 2H (ASTM D3363-92A), crosshatch adhesion of 4B-5B (ASTM D3359-95), and impact resistance of 184 kg-cm direct (ASTM D2794-93).

Refrigerant metering shall be accomplished by thermostatic expansion valve only. Expansion valves shall be dual port balanced type with external equalizer for optimum refrigerant metering. Units shall be designed and tested for operating ranges of entering water temperatures from -6.7° to 48.9°C. Reversing valve shall be four-way solenoid activated refrigerant valve, which shall default to heating mode should the solenoid fail to function. If the reversing valve solenoid defaults to cooling mode, an additional low temperature thermostat must be provided to prevent over-cooling an already cold room.

Option: The unit will be supplied with cupro-nickel coaxial water to refrigerant heat exchanger.

Option: The unit will be supplied with internally factory mounted two-way water valve for variable speed pumping requirements. A factory-mounted or field-installed high pressure switch shall be installed in the water piping to disable compressor operation in the event water pressures build due to water freezing in the piping system.

Option: The unit will be supplied with internally factory mounted automatic water flow regulators.

Option: The unit will be supplied with internally mounted secondary pump for primary/secondary applications, specifically one-pipe systems.

Option: The unit shall be supplied with extended range Insulation option, which adds closed cell insulation to internal water lines, and provides insulation on suction side refrigeration tubing including refrigerant to water heat exchanger.

Option: The refrigerant to air heat exchanger shall be coated.

Piping:

Water piping shall terminate in the same location regardless of the connection and valve options.

Option: Threaded MPT copper fittings (sweat connections are standard).

Option: Threaded FPT copper fittings (sweat connections are standard).

Drain Pan:

The drain pan shall be constructed of galvanized steel and have a powder coat paint application to further inhibit corrosion. This corrosion protection system shall meet the stringent 1000 hour salt spray test per ASTM B117. If plastic type material is used, it must be HDPE (High Density Polyethylene) to avoid thermal cycling shock stress failure over the lifetime of the unit. Drain pan shall be insulated. Drain outlet shall be located at pan as to allow complete and unobstructed drainage of condensate. The unit as standard will be supplied with solid-state electronic condensate overflow protection. **Mechanical float switches will NOT be accepted.**

Option: The unit shall be supplied with stainless steel drain pan.

Electrical:

Unit controls shall be located under the hinged control door in the sloped top grille. Operating controls shall consist of slide switches to select "OFF", "HEAT," "COOL," "AUTO" (when equipped with auto change-over option – "AUTO" is not available for standard manual change-over controls), Fan "AUTO" (fan cycles with compressor), Fan "ON" (continuous fan), Fan "LO" (low speed fan), and Fan "HI" (high speed fan). Temperature adjustment shall be accomplished via two push buttons, one labeled with an arrow up, and the other labeled with an arrow down. Controls shall include an LCD display for display of temperature and setpoint. **Units without an LCD display shall not be accepted.**

ClimateMaster works continually to improve its products. As a result, the design and specifications of each product at the time of order may be changed without notice and may not be as described herein. Please contact ClimateMaster's Customer Service Department at +1-405-745-6000 for specific information on the current design and specifications. Statements and other information contained herein are not express warranties and do not form the basis of any bargain between the parties, but are merely ClimateMaster's opinion or commendation of its products. The latest version of this document is available at climatemaster.com.



A control box shall be located above the unit compressor compartment and shall contain operating controls as outlined in the paragraph above, 24VAC transformer, double-pole compressor relay, and solid-state controller for complete unit operation. Reversing valve and fan motor wiring shall be routed through this electronic controller. Units shall be name-plated for use with time delay fuses or HACR circuit breakers. A unit-mounted digital thermostat with a remote sensor measuring return air temperature shall control the compressor operation for heating and cooling. Control shall be equipped with a fan switch (provides options to cycle fan with compressor or provide continuous fan) and a fault indicator light. **Units without a fault indicator light shall not be accepted.**

Option: Digital ACO unit mounted thermostat (MCO is standard).

Option: Provisions for remote thermostat (single fan speed).

Option: Disconnect Switch, Non-Fused.

Solid State Control System (CXM):

Units shall have a solid-state control system. **Units utilizing electro-mechanical control shall not be acceptable.** The control system microprocessor board shall be specifically designed to protect against building electrical system noise contamination, EMI, and RFI interference. The control system shall interface with a heat pump type thermostat. The control system shall have the following features:

- a. Anti-short cycle time delay on compressor operation.
- b. Random start on power up mode.
- c. Low voltage protection.
- d. High voltage protection.
- e. Unit shutdown on high or low refrigerant pressures.
- f. Unit shutdown on low water temperature.
- g. Condensate overflow electronic protection.
- h. Option to reset unit at thermostat or disconnect.
- i. Automatic intelligent reset. Unit shall automatically reset the unit 5 minutes after trip if the fault has cleared. If a fault occurs 3 times sequentially without thermostat meeting temperature, then lockout requiring manual reset will occur.
- j. Ability to defeat time delays for servicing.
- k. Light emitting diode (LED) on circuit board to indicate high pressure, low pressure, low voltage, high voltage, low water/air temperature cut-out, condensate overflow, and control voltage status.
- l. The low-pressure switch shall not be monitored for the first 120 seconds after a compressor start command to prevent nuisance safety trips.
- m. 24V output to cycle a motorized water valve or other device with compressor contactor.
- n. Unit Performance Sentinel (UPS). The UPS warns when the heat pump is running inefficiently.
- o. Water coil low temperature sensing (selectable for water or anti-freeze).
- p. Air coil low temperature sensing.

NOTE: Units not providing the 8 safety protections of anti-short cycle, low voltage, high voltage, high refrigerant pressure, low pressure (loss of charge), air coil low temperature cut-out, water coil low temperature cut-out, and condensate overflow protections will not be accepted.

Option: Enhanced solid state control system (DXM)

This control system features two stage control of cooling and two stage control of heating modes for exacting temperature and dehumidification purposes.

This control system coupled with a multi-stage thermostat will better dehumidify room air by automatically running the heat pump's fan at lower speed on the first stage of cooling thereby implementing low sensible heat ratio cooling. On the need for higher cooling performance the system will activate the second stage of cooling and automatically switch the fan to the higher fan speed setting. This system may be further enhanced with a humidistat. **Units not having automatic low sensible heat ratio cooling will not be accepted; as an alternate a hot gas reheat coil may be provided with control system for automatic activation.**

Control shall have all of the above mentioned features of the CXM control system along with the following expanded features:

- a. Removable thermostat connector.
- b. Night setback control.
- c. Random start on return from night setback.
- d. Minimized reversing valve operation (Unit control logic shall only switch the reversing valve when cooling is demanded for the first time. The reversing valve shall be held in this position until the first call for heating, ensuring quiet operation and increased valve life.)
- e. Override temperature control with 2-hour timer for room occupant to override setback temperature at the thermostat.
- f. Dry contact night setback output for digital night setback thermostats.
- g. Ability to work with heat pump or heat/cool (Y, W) type thermostats.
- h. Ability to work with heat pump thermostats using O or B reversing valve control.
- i. Emergency shutdown contacts.
- j. Boilerless system heat control at low loop water temperature.

ClimateMaster works continually to improve its products. As a result, the design and specifications of each product at the time of order may be changed without notice and may not be as described herein. Please contact ClimateMaster's Customer Service Department at +1-405-745-6000 for specific information on the current design and specifications. Statements and other information contained herein are not express warranties and do not form the basis of any bargain between the parties, but are merely ClimateMaster's opinion or commendation of its products. The latest version of this document is available at climatemaster.com.



- k. Ability to allow up to 3 units to be controlled by one thermostat.
- l. Relay to operate an external damper.
- m. Ability to automatically change fan speed from multistage thermostat.
- n. Relay to start system pump.
- o. 75 VA control transformer. Control transformer shall have load side short circuit and overload protection via a built in circuit breaker.

Remote Service Sentinel (CXM/DXM):

Solid state control system shall communicate with thermostat to display (at the thermostat) the unit status, fault status, and specific fault condition, as well as retrieve previously stored fault that caused unit shutdown. The Remote Service Sentinel allows building maintenance personnel or service personnel to diagnose unit from the wall thermostat. The control board shall provide a signal to the thermostat fault light, indicating a lockout. Upon cycling the G (fan) input 3 times within a 60 second time period, the fault light shall display the specific code as indicated by a sequence of flashes. A detailed flashing code shall be provided at the thermostat LED to display unit status and specific fault status such as over/under voltage fault, high pressure fault, low pressure fault, low water temperature fault, condensate overflow fault, etc. **Units that do not provide this remote service sentinel shall not be acceptable.**

Option: Lonworks interface system

Units shall have all the features listed above (either CXM or DXM) and the control board will be supplied with a LONWORKS interface board, which is LONMark certified. This will permit all units to be daisy chained via a 2-wire twisted pair shielded cable. The following points must be available at a central or remote computer location:

- a. space temperature
- b. leaving water temperature
- c. discharge air temperature
- d. command of space temperature setpoint
- e. cooling status
- f. heating status
- g. low temperature sensor alarm
- h. low pressure sensor alarm
- i. high pressure switch alarm
- j. condensate sensor alarm
- k. hi/low voltage alarm
- l. fan "ON/AUTO" position of space thermostat as specified above
- m. unoccupied/occupied command
- n. cooling command
- o. heating command
- p. fan "ON/AUTO" command
- q. fault reset command
- r. itemized fault code revealing reason for specific shutdown fault (any one of 7)

This option also provides the upgraded 75VA control transformer with load side short circuit and overload protection via a built in circuit breaker.

Option. MPC (Multiple Protocol Control) interface system

Units shall have all the features listed above (either CXM or DXM) and the control board will be supplied with a Multiple Protocol interface board. Available protocols are BACnet MS/TP, Modbus, or Johnson Controls N2. The choice of protocol shall be field selectable/changeable via the use of a simple selector switch. **Protocol selection shall not require any additional programming or special external hardware or software tools.** This will permit all units to be daisy chain connected by a 2-wire twisted pair shielded cable. The following points must be available at a central or remote computer location:

- a. space temperature
- b. leaving water temperature
- c. discharge air temperature
- d. command of space temperature setpoint
- e. cooling status
- f. heating status
- g. low temperature sensor alarm
- h. low pressure sensor alarm
- i. high pressure switch alarm
- j. condensate overflow alarm
- k. hi/low voltage alarm
- l. fan "ON/AUTO" position of space thermostat as specified above
- m. unoccupied/occupied command
- n. cooling command
- o. heating command
- p. fan "ON/AUTO" command
- q. fault reset command
- r. itemized fault code revealing reason for specific shutdown fault (any one of 7)

ClimateMaster works continually to improve its products. As a result, the design and specifications of each product at the time of order may be changed without notice and may not be as described herein. Please contact ClimateMaster's Customer Service Department at +1-405-745-6000 for specific information on the current design and specifications. Statements and other information contained herein are not express warranties and do not form the basis of any bargain between the parties, but are merely ClimateMaster's opinion or commendation of its products. The latest version of this document is available at climatemaster.com.



This option also provides the upgraded 75VA control transformer with load side short circuit and overload protection via a built in circuit breaker.

Warranty:

Climate Master shall warranty equipment for a period of 12 months from start up or 18 months from shipment (whichever occurs first).

Option: Two-Year Extended Warranty provides coverage for a period of 24 months from date of start-up or 30 months from the date of shipment (whichever occurs first).

Option: Extended 4-year compressor warranty covers compressor for a total of 5 years.

FIELD INSTALLED OPTIONS

Hose Kits:

Hoses shall be 31cm long, braided stainless steel; fire rated hoses complete with adapters. Only fire rated hoses will be accepted.

Note: Threaded connection piping option must be ordered for hose kit connections.

Option: 61cm hose lengths instead of standard 31cm length.

Valves:

The following valves are available and will be shipped loose:

- a. Ball valve; bronze material, standard port full flow design, FPT connections.
- b. Ball valve with memory stop and PT port.
- c. "Y" strainer with blowdown valve; bronze material, FPT connections
- d. Motorized water valve; slow acting, 24v, FPT connections.

Hose Kit Assemblies:

The following assemblies ship with the valves already assembled to the hose described:

- a. Supply and return hoses having ball valve with PT port.
- b. Supply hose having ball valve with PT port; return hose having automatic flow regulator valve with PT ports, and ball valve.
- c. Supply hose having "Y" strainer with blowdown valve, and ball valve with PT port; return hose having automatic flow regulator with PT ports, and ball valve.
- d. Supply hose having "Y" strainer with blowdown valve, and ball valve with PT port; return hose having ball valve with PT port.

Thermostats:

The thermostat shall be a ClimateMaster mechanical or electronic type thermostat as selected below with the described features:

- a. Single Stage Standard Manual Changeover (ATM11C11)
Thermostat shall be a single-stage, horizontal mount, manual changeover with HEAT-OFF-COOL system switch and fan ON-AUTO switch. Thermostat shall have a mechanical temperature setpoint indicator. Thermostat shall only require 4 wires for connection. Mercury bulb thermostats are not acceptable.
- b. Single Stage Digital Auto or Manual Changeover (ATA11U01)
Thermostat shall be a single-stage, digital, auto or manual changeover with HEAT-OFF-COOL-AUTO system switch and fan ON-AUTO switch. Thermostat shall have an LCD display with temperature and setpoint(s) in °F or °C. The Thermostat shall provide permanent memory of setpoint(s) without batteries. A fault LED shall be provided to display specific fault condition. Thermostat shall provide temperature display offset for custom applications.
- c. Single Stage Digital Automatic or Manual Changeover with Two-Speed Fan Control (ATA11C04) – DXM and PSC Fan required
Thermostat shall be a single-stage, digital, auto or manual changeover with HEAT-OFF-COOL-AUTO system switch, fan ON-AUTO switch, and fan LO-HI switch. Thermostat shall have an LCD display with temperature and setpoint(s) in °F or °C. A fault LED shall be provided to display specific fault condition. Thermostat shall allow use of an accessory remote temperature sensor (AST009), but may be operated with internal sensor via orientation of a jumper.
- d. Single Stage Digital Automatic Changeover (ATA11C06)
Thermostat shall be a single-stage, digital, auto or manual changeover with HEAT-OFF-COOL-AUTO system switch and fan ON-AUTO switch. Thermostat shall have an LCD display with temperature and setpoint(s) in °F or °C. A fault LED shall be provided to display specific fault condition. Thermostat shall allow use of an accessory remote temperature sensor (AST009), but may be operated with internal sensor via orientation of a jumper.



- e. Multistage Digital Automatic Changeover (ATA22U01)
Thermostat shall be multi-stage (2H/2C), manual or automatic changeover with HEAT-OFF-COOL-AUTO-EM HEAT system settings and fan ON-AUTO settings. Thermostat shall have an LCD display with temperature, setpoint(s), mode, and status indication. The temperature indication shall be selectable for °F or °C. The thermostat shall provide permanent memory of setpoint(s) without batteries. A fault LED shall be provided to indicate specific fault condition(s). Thermostat shall provide temperature display offset for custom applications. Thermostat shall allow unit to provide better dehumidification with optional DXM controller by automatically using lower fan speed on stage 1 cooling (higher latent cooling) as main cooling mode, and automatically shifting to high speed fan on stage 2 cooling.
- f. Multistage Manual Changeover Programmable 5/2 Day (ATP21U01)
Thermostat shall be 5 day/2 day programmable (with up to 4 setpoints per day), multi-stage (2H/1C), manual changeover with HEAT-OFF-COOL-EM HEAT system settings and fan ON-AUTO settings. Thermostat shall have an LCD display with temperature, setpoint(s), mode, and status indication. The temperature indication shall be selectable for °F or °C. The thermostat shall provide permanent memory of setpoint(s) without batteries. Thermostat shall provide convenient override feature to temporarily change setpoint.
- g. Multistage Automatic or Manual Changeover Programmable 7 Day (ATP32U03)
Thermostat shall be 7 day programmable (with up to 4 setpoints per day), multi-stage (3H/2C), automatic or manual changeover with HEAT-OFF-COOL-AUTO-EM HEAT system settings and fan ON-AUTO settings. Thermostat shall have a blue backlit dot matrix LCD display with temperature, setpoints, mode, and status indication. The temperature indication shall be selectable for °F or °C. Time display shall be selectable for 12 or 24 hour clock. Fault identification shall be provided (when used with ClimateMaster CXM or DXM controls) to simplify troubleshooting by providing specific unit fault at the thermostat with red backlit LCD during unit lockout. The thermostat shall provide permanent memory of setpoints without batteries. Thermostat shall provide heating setpoint range limit, cooling setpoint range limit, temperature display offset, keypad lockout, dead-band range setting, and inter-stage differential settings. Thermostat shall provide progressive recovery to anticipate time required to bring space temperature to the next programmed event. Thermostat shall provide an installer setup for configuring options and for setup of servicing contractor name and contact information. Thermostat shall allow the use of an accessory remote and/or outdoor temperature sensor (AST008). Thermostat navigation shall be accomplished via five buttons (up/down/right/left/select) with menu-driven selections for ease of use and programming.
- h. Multistage Automatic or Manual Changeover Programmable 7 Day with Humidity Control (ATP32U04)
Thermostat shall be 7 day programmable (with up to 4 setpoints per day), multi-stage (3H/2C), automatic or manual changeover with HEAT-OFF-COOL-AUTO-EM HEAT system settings and fan ON-AUTO settings. Separate dehumidification and humidification setpoints shall be configurable for discreet outputs to a dehumidification option and/or an external humidifier. Installer configuration mode shall allow thermostat dehumidification mode to operate with ClimaDry® reheat or with ECM fan dehumidification mode via settings changes. Thermostat shall have a blue backlit dot matrix LCD display with temperature, relative humidity, setpoints, mode, and status indication. The temperature indication shall be selectable for °F or °C. Time display shall be selectable for 12 or 24 hour clock. Fault identification shall be provided (when used with ClimateMaster CXM or DXM controls) to simplify troubleshooting by providing specific unit fault at the thermostat with red backlit LCD during unit lockout. The thermostat shall provide permanent memory of setpoints without batteries. Thermostat shall provide heating setpoint range limit, cooling setpoint range limit, temperature display offset, keypad lockout, dead-band range setting, and inter-stage differential settings. Thermostat shall provide progressive recovery to anticipate time required to bring space temperature to the next programmed event. Thermostat shall provide an installer setup for configuring options and for setup of servicing contractor name and contact information. Thermostat shall allow the use of an accessory remote and/or outdoor temperature sensor (AST008). Thermostat navigation shall be accomplished via five buttons (up/down/right/left/select) with menu-driven selections for ease of use and programming.

DDC Sensors:

ClimateMaster wall mounted DDC sensor to monitor room temperature and interfaces with optional interface system described above. Several types as described below:

- a. Sensor only with no display (LON and MPC).
- b. Sensor with override (LON only).
- c. Sensor with setpoint adjustment and override (MPC only).
- d. Sensor with setpoint adjustment and override, LCD display, status/fault indication (LON and MPC).

Subbase Grille:

Decorative louvered grille covers the front of subbase including the large return air opening, order separate and field attach.



Date:	Item:	Action:
14 November, 2011	Cabinet Dimensions Series Nomenclature Engineering Specifications	Updated
09 August, 2011	Unit Maximum Working Water Pressure	Updated to Reflect New Safeties
11 August, 2010	Entire Document	Remove I-P Units Updated Guide Specifications and Field Options
3 August, 2010	Cabinet Dimensions	Updated
3 August, 2010	Wiring Diagrams	Updated
12 June, 2008	Engineering Specifications	Updated
20 November, 2007	First Published	